

Intelligent power switch

Features

- Low side or high side switch configuration
- 6 V to 48 V supply voltage range
- Overload and short circuit protections
- Internal voltage clamping
- Supply and output reversal protection
- Thermal shutdown
- GND and V_S open wire protection
- Adjustable delay at switch on
- Indicator status led driver
- +5 V regulated aux. voltage
- High burst immunity

Description

The TDE1708DFT is an integrated power switch with up to 48 V power supply capability. Two output configurations are possible:

Load to GND (high side mode)

Load to V_S (low side mode)

Especially dedicated to proximity detectors, its internal +5 V supply can be used to supply external circuits (See also AN495).

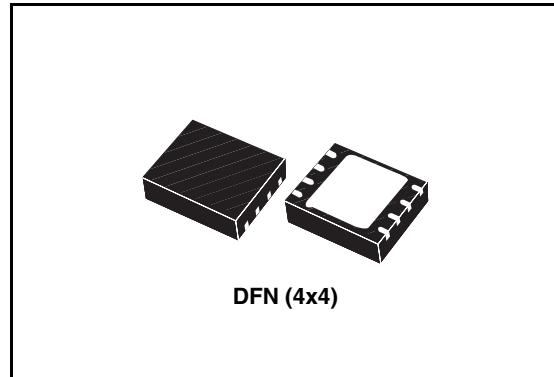

A signal is internally generated to block the In signal, and prevent activation of the output switch, as long as an abnormal condition is detected. The power-on transition, as well as the chip over temperature and the output overcurrent, concur to the generation of such signal. A minimum delay of 25 ms (Typ. value) is added to the trailing edge of such signal to ensure that a stable normal situation is present when the signal disappears. The delay (of the disappearance of the block signal; no delay at its on set) can be further increased connecting a capacitor between pin3 and ground. It can drive resistive or inductive loads.

Table 1. Device summary

Order code	Temp. range, °C	Package	Packing
TDE1708DFT	-25 °C to +85 °C	DFN (4x4)	Tape and reel

Contents

1	Block and pin connection diagrams	3
2	Electrical specifications	5
2.1	Thermal data	5
2.2	Absolute maximum ratings	5
2.3	Electrical characteristics	6
2.4	Dynamic information	7
3	Application information	8
3.1	Adjustable input hysteresis circuit	9
4	Package mechanical data	10
4.1	Foot print recommended	10
4.2	DFN (4x4) mechanical data and package dimensions	11
5	Revision history	13

1 Block and pin connection diagrams

Figure 1. Block diagram

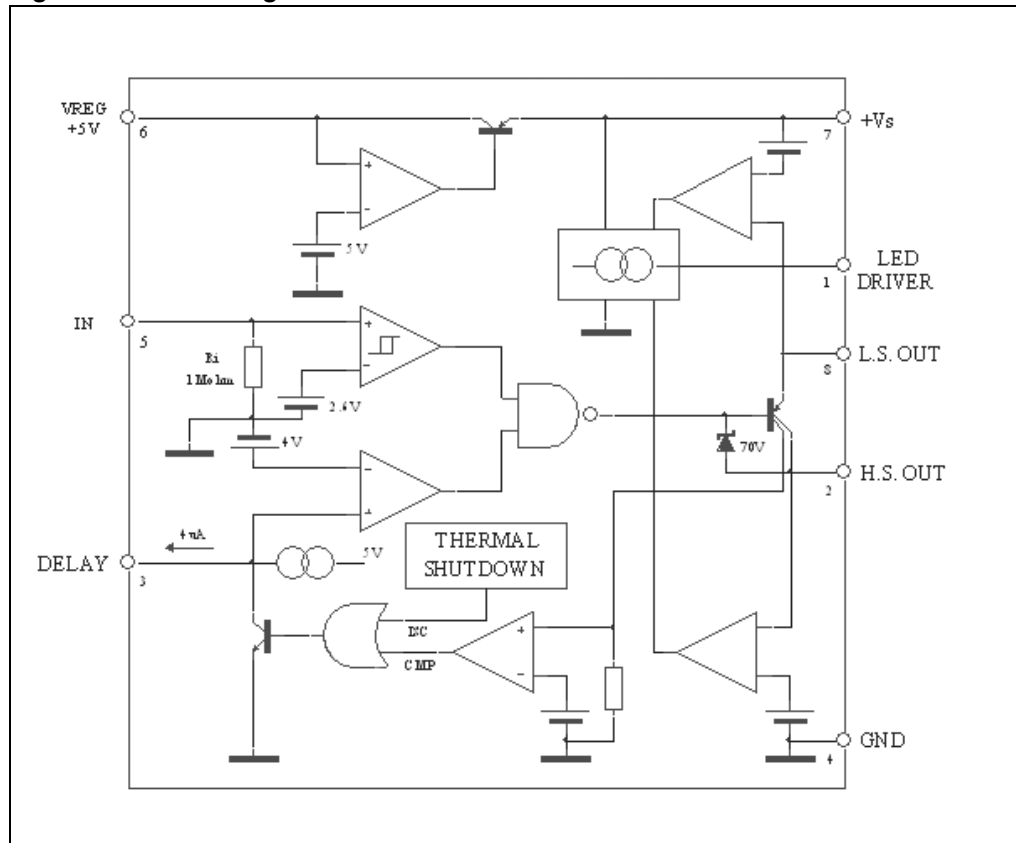

Figure 2. Pin connection diagram (top view)

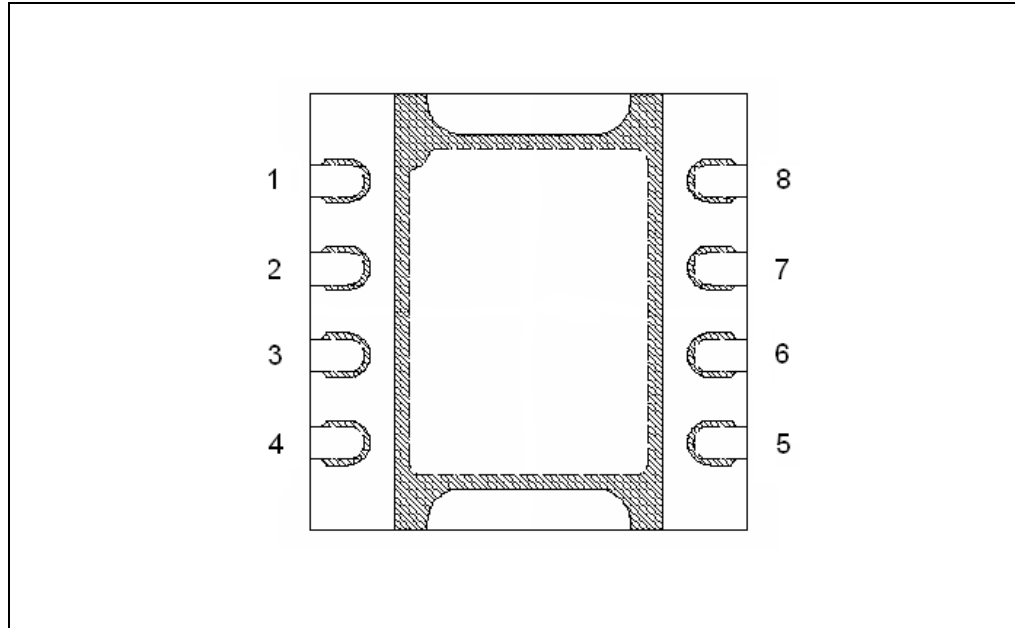

Table 2. Pin functions

Pin N°	Function
1	Led driver
2	High side output
3	Delay capacitance source
4	Ground
5	Input
6	Reg. voltage source
7	Supply voltage
8	Low side output

Note: Lead frame can be connected to ground.

2 Electrical specifications

2.1 Thermal data

Table 3. Thermal data

Symbol	Description	Value	Unit
R_{thJA}	Thermal resistance junction-ambient. (max)	32 ⁽¹⁾	°C/W
R_{thJC}	Thermal resistance junction-case. (max)	1.2	°C/W

1. Soldered to a 4 layer board with 4 vias in the pad.

2.2 Absolute maximum ratings

Table 4. Absolute maximum ratings

Symbol	Parameter	Value	Unit
V_S	Supply voltage	50	V
V_S	Supply reverse voltage	50	V
I_o	Output current	internally limited	A
V_{reg}	Regulated voltage pin	0 to 7	V
V_{delay}	Delay cap. source pin	0 to 5	V
V_o	Output dif. voltage	55	V
V_i	Input voltage	-10 to 50	V
T_J	Junction operating temperature	Internally limited	°C
T_{stg}	Storage temperature range	-55 to 150	°C
P_{tot}	Power dissipation	internally limited	mW
E_i	Energy inductive load	100	mJ

2.3 Electrical characteristics

Table 5. Electrical characteristics
($V_S = 24\text{ V}$; $T_J = -25\text{ to }+85\text{ }^\circ\text{C}$ unless otherwise specified)

Symbol	Parameter	Test conditions	Min	Typ	Max	Unit
V_S	Supply voltage		6		48	V
I_{SR}	Supply reverse current	$V_{SR} = -48\text{ V}$			1.5	mA
I_Q	Quiescent current	$I_{reg} = I_{led} = 0$; $V_i < 2\text{ V}$; $V_S = 6\text{ to }48\text{ V}$			1.5	mA
I_O	Output current	$V_S = 6\text{ to }48\text{ V}$			250	mA
V_{SAT}	Output voltage drop	$I_O = 200\text{ mA}$		1	1.5	V
I_{SCLS}	Short circuit current in low side configuration		0.3	0.4	0.6	A
I_{SCHS}	Short circuit current in high side configuration		0.25	0.3	0.40	A
V_{CL}	Internal voltage clamp	$I_{CL} = 10\text{ mA}$	55		70	V
I_{OLK}	Output leakage	(Pin 2) $V_i < 2\text{ V}$; $V_O = 0\text{ to }V_S$ (Pin 8)		100	300 100	μA μA
V_{ITH}	Input voltage threshold		2		3	V
V_{IHIS}	Input threshold hysteresis			300		mV
I_{IK}	Input current	$V_i = 5\text{ V}$		2	5	μA
V_{REG}	Regulated output voltage	$I_{reg} < 5\text{ mA}$	4.5	5	5.5	V
I_{SCR}	Short circuit regulated		6	30	50	mA
I_{REG}	Output regulator current	$V_S = 35\text{ V}$ $V_S = 48\text{ V}$			6 4	mA mA
I_{OLD}	Current source sink led driver	Output ON (\pm)	2	3	4	mA
V_{OLD}	Voltage drop led driver	$I_{OS} = 2\text{ mA } (\pm)$		1.2	1.6	V
I_{OLDK}	LED driver (off) Leak.	$V_i < 2\text{ V}$; $R_L < 1\text{ k}\Omega$			10	μA
I_{DCH}	Del. cap. charge current	$T_J = 25\text{ }^\circ\text{C}$	2	4	6	μA
V_{DTH}	Delay voltage trigger			4		V
T_{TSD}	Thermal shutdown temperature			180		$^\circ\text{C}$

2.4 Dynamic information

Table 6. Dynamic information ($V_S = 24\text{ V}$; $T_J = 25\text{ °C}$; $R_L = 48\ \Omega$)

Symbol	Parameter	Test conditions	Min	Typ	Max	Unit
t_{on}	Propagation turn on time	$V_i = 0\text{ to }5\text{V}$		15		μs
t_{off}	Propagation turn off time			15		μs
t_{don}	Delayed turn on time / nF delay capacitor		0.65	1	2	ms
$t_{d\ min}$	Minimum delayed t_{on} Delay capacitor = 0			25		μs

3 Application information

The LED driver tells the output status. It can source or sink current ($I_{old\ typ} = 3\text{ mA}$), according to the output configuration chosen. The thresholds, represented by the output comparator in the block diagram, are set at about 1.5 V - 2 V.

For instance, in the high side load case of the Application Circuit, when the voltage on pin 8 (the output) differs from V_{CC} less than 1.5 V, the output is sensed in "OFF" state and the LED driver is disabled.

If instead pin 8 differs from V_{CC} more than 3 V (the output comparator threshold value plus the drop voltage on the LED), then the output is sensed "ON" and the driver will force the current on the LED.

Figure 3. Low side driver topology

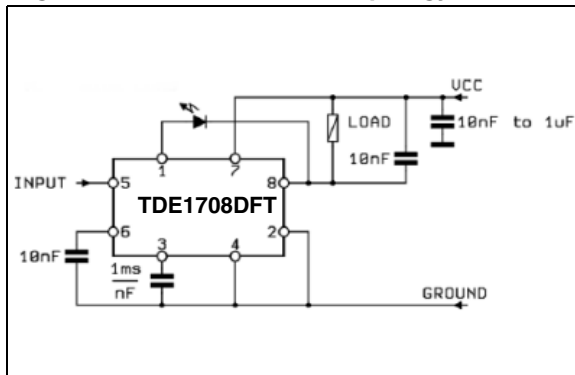
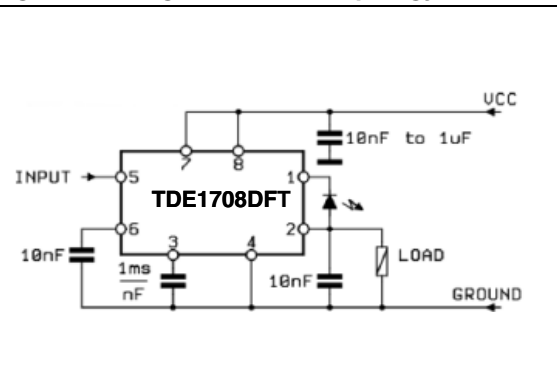

Figure 4. High side driver topology



3.1 Adjustable input hysteresis circuit

The TDE1708DFT is a device realized in bipolar technology and therefore it has the usual problems of temperature compensation that such technology involves; despite all it maintains an input dynamics within 1 V over industrial temperatures range.

In all input voltage range it will guarantee a high impedance of 1 M Ω determining an input current about 2 μ A.

Exploiting this input high impedance is possible connects a sensor directly on it and bypass the obstacle of active signal conditioning circuit using a voltage firm point as ground of sensor, the delay capacitor, connected on the pin 3, as low pass filter and capacitor on Vreg pin to minimize the noise on it and protect for errors the low-voltage internal circuits, according AN495.

In [Figure 5](#), the input external network is optimized for accepting both a sensor with ground connected to the body and a sensor with independent ground.

In order to ground the body of the sensor, J1 has to be shorted, while J2 opened and connect the sensor on M3; in case of independent ground J1 must be opened, J2 shorted and the sensor connected on M4.

DL1 indicate commutation status of the device output and C3 realize a simple output filtering in case is used an inductive load. With C2 about 10 nF we obtain a good filtering and immunity from input voltage noise. C4 is 4,7nF according AN495.

R2 is an optional resistor plugged only when the sensor needs to adapt its impedance with the input impedance of device.

Figure 5. Application circuit for adjustable input hysteresis

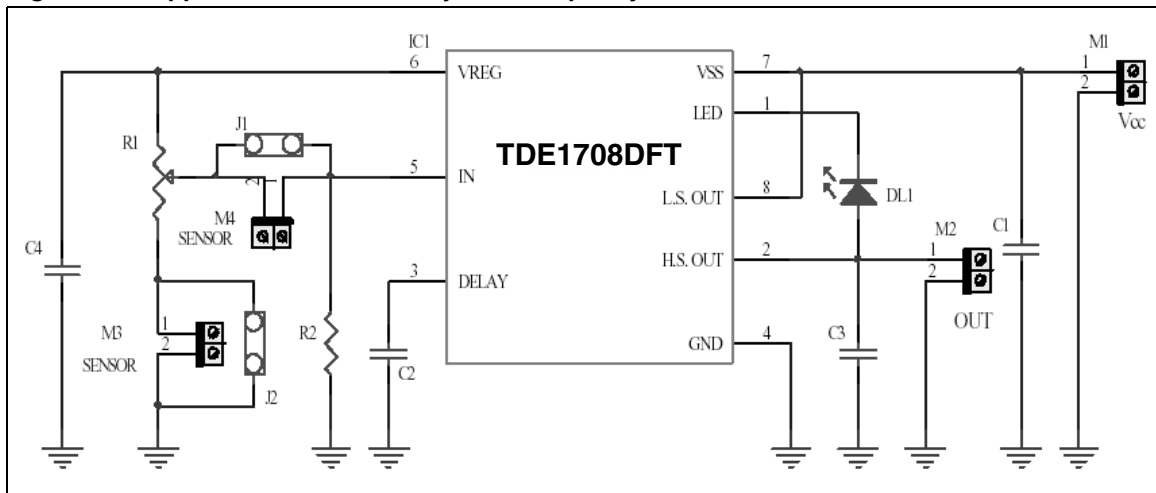

4 Package mechanical data

In order to meet environmental requirements, ST offers these devices in different grades of ECOPACK[®] packages, depending on their level of environmental compliance. ECOPACK[®] specifications, grade definitions and product status are available at: www.st.com. ECOPACK is an ST trademark.

4.1 Foot print recommended

Figure 6. Foot print

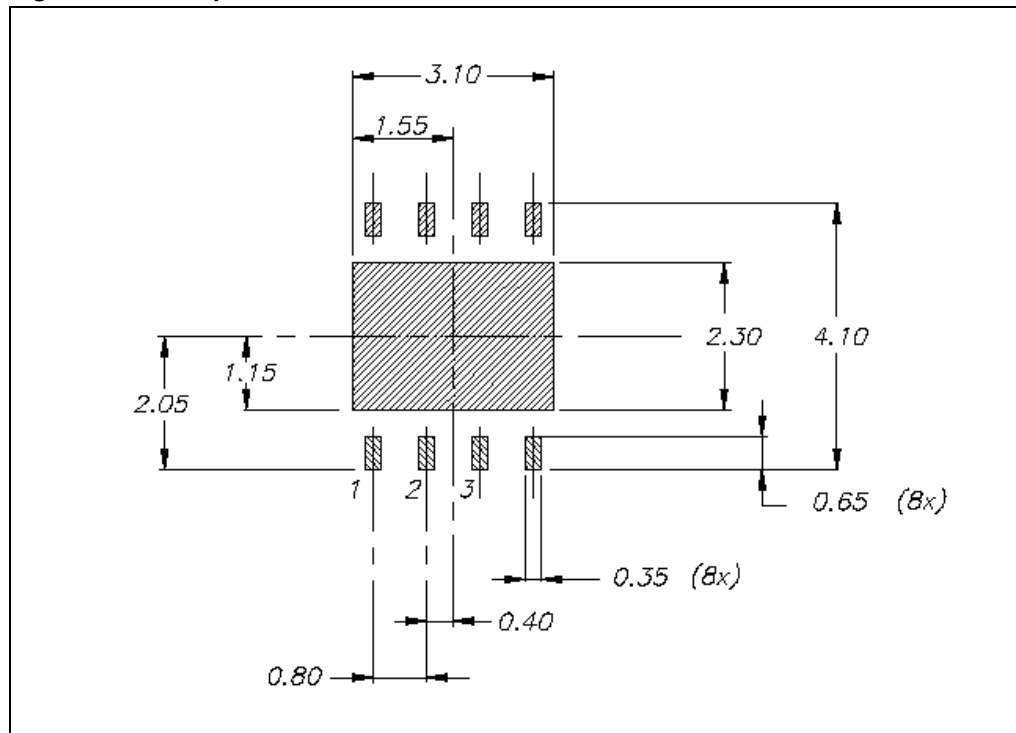

4.2 DFN (4x4) mechanical data and package dimensions

Table 7. Package dimensions

Dim.	mm		
	Typ	Min	Max
A	0.90	0.80	1
A1	0.02	0	0.05
A3	0.20		
b	0.30	0.23	0.38
D	4	3.90	4.10
D2	3	2.82	3.23
E	4	3.90	4.10
E2	2.20		2.30
e	0.80		
L	0.50	0.40	0.60

Figure 7. Package dimension

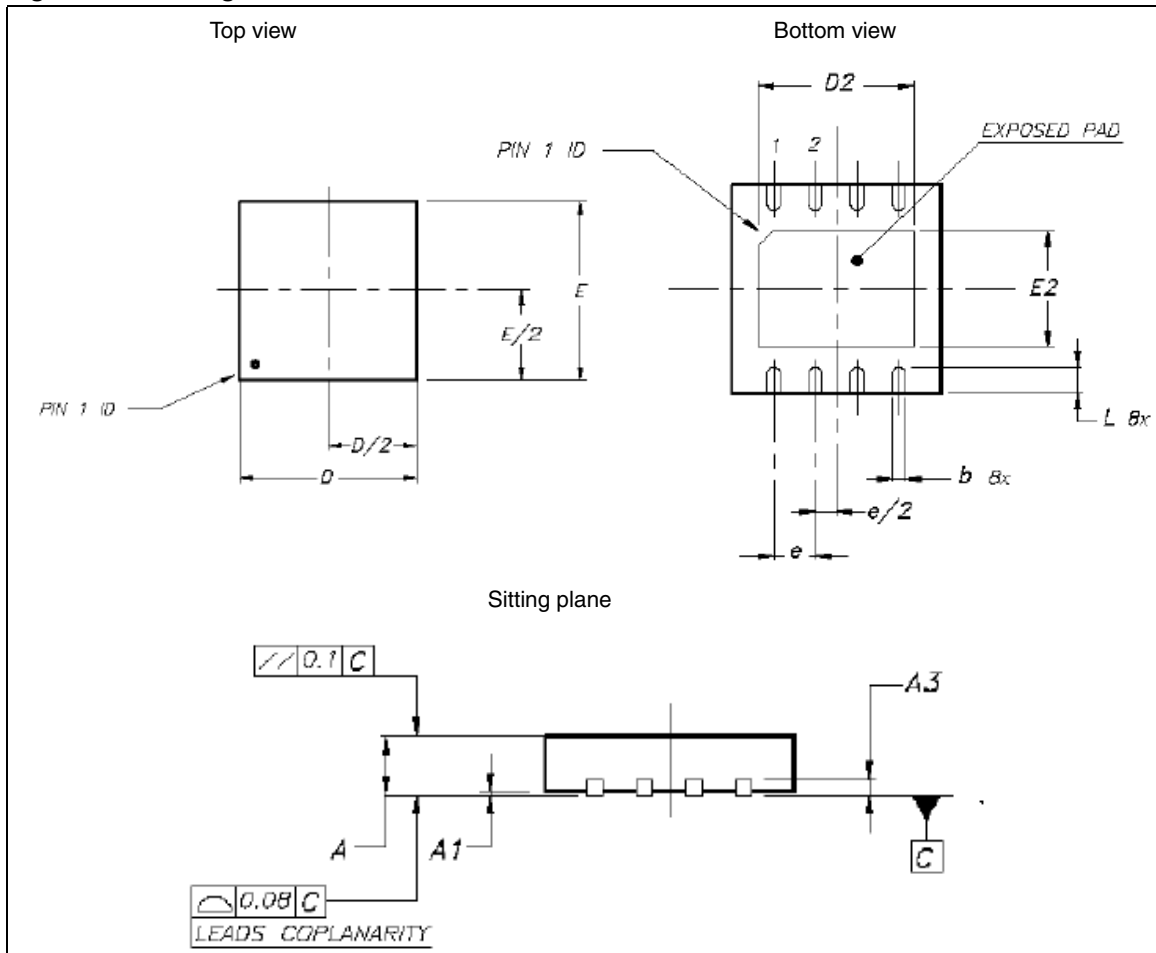

5 Revision history

Figure 8. Document revision history

Date	Revision	Changes
26-Jun-2006	1	Initial release.
31-Oct-2006	2	Updated package in cover page, inserted low/high side I_{SC} in Table 5 .
09-Jan-2007	3	Updated I_{SCHS} in Table 5 on page 6 .
27-Feb-2009	4	Updated cover page

Please Read Carefully:

Information in this document is provided solely in connection with ST products. STMicroelectronics NV and its subsidiaries ("ST") reserve the right to make changes, corrections, modifications or improvements, to this document, and the products and services described herein at any time, without notice.

All ST products are sold pursuant to ST's terms and conditions of sale.

Purchasers are solely responsible for the choice, selection and use of the ST products and services described herein, and ST assumes no liability whatsoever relating to the choice, selection or use of the ST products and services described herein.

No license, express or implied, by estoppel or otherwise, to any intellectual property rights is granted under this document. If any part of this document refers to any third party products or services it shall not be deemed a license grant by ST for the use of such third party products or services, or any intellectual property contained therein or considered as a warranty covering the use in any manner whatsoever of such third party products or services or any intellectual property contained therein.

UNLESS OTHERWISE SET FORTH IN ST'S TERMS AND CONDITIONS OF SALE ST DISCLAIMS ANY EXPRESS OR IMPLIED WARRANTY WITH RESPECT TO THE USE AND/OR SALE OF ST PRODUCTS INCLUDING WITHOUT LIMITATION IMPLIED WARRANTIES OF MERCHANTABILITY, FITNESS FOR A PARTICULAR PURPOSE (AND THEIR EQUIVALENTS UNDER THE LAWS OF ANY JURISDICTION), OR INFRINGEMENT OF ANY PATENT, COPYRIGHT OR OTHER INTELLECTUAL PROPERTY RIGHT.

UNLESS EXPRESSLY APPROVED IN WRITING BY AN AUTHORIZED ST REPRESENTATIVE, ST PRODUCTS ARE NOT RECOMMENDED, AUTHORIZED OR WARRANTED FOR USE IN MILITARY, AIR CRAFT, SPACE, LIFE SAVING, OR LIFE SUSTAINING APPLICATIONS, NOR IN PRODUCTS OR SYSTEMS WHERE FAILURE OR MALFUNCTION MAY RESULT IN PERSONAL INJURY, DEATH, OR SEVERE PROPERTY OR ENVIRONMENTAL DAMAGE. ST PRODUCTS WHICH ARE NOT SPECIFIED AS "AUTOMOTIVE GRADE" MAY ONLY BE USED IN AUTOMOTIVE APPLICATIONS AT USER'S OWN RISK.

Resale of ST products with provisions different from the statements and/or technical features set forth in this document shall immediately void any warranty granted by ST for the ST product or service described herein and shall not create or extend in any manner whatsoever, any liability of ST.

ST and the ST logo are trademarks or registered trademarks of ST in various countries.

Information in this document supersedes and replaces all information previously supplied.

The ST logo is a registered trademark of STMicroelectronics. All other names are the property of their respective owners.

© 2009 STMicroelectronics - All rights reserved

STMicroelectronics group of companies

Australia - Belgium - Brazil - Canada - China - Czech Republic - Finland - France - Germany - Hong Kong - India - Israel - Italy - Japan - Malaysia - Malta - Morocco - Singapore - Spain - Sweden - Switzerland - United Kingdom - United States of America

www.st.com