



ST2052

Current limited power distribution switches

Not recommended for new design

Features

- 80 mΩ high-side MOSFET switch
- 500 mA continuous current per channel
- independent thermal and short-circuit protection with overcurrent logic output
- Operating range from 2.7 V to 5.5 V
- CMOS- and TTL-compatible enable inputs
- 10 ms OC_N fault-blanking
- 2.5 ms typical rise time
- Undervoltage lock out
- 10 μA maximum standby supply current
- Ambient temperature range, -40 °C to 85 °C
- ESD protection

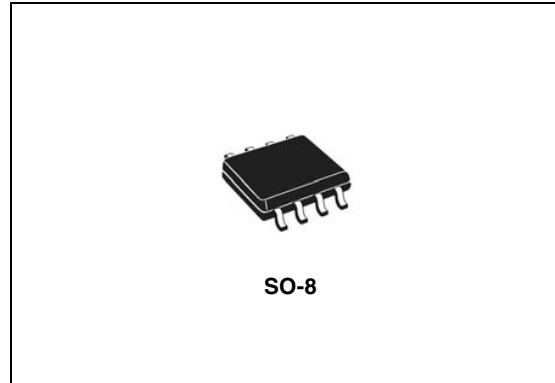

Table 1. Device summary

Order code	Package	Packaging
ST2052BD ⁽¹⁾	SO-8	Tube (50 parts per tube, 40 tube per box)
ST2052BDR ⁽¹⁾	SO-8	Tape and reel (2500 parts per reel)

1. Not recommended for new design (refer to STMPS2252MTR). Contact ST sales office for availability.

Contents

1	Description	3
2	Block diagram	4
3	Pin connections	5
4	Electrical ratings	6
	4.1 Absolute maximum ratings	6
	4.2 Recommended operating conditions	6
5	Electrical characteristics	7
6	Package mechanical data	10
7	Revision history	13

1 Description

The ST2052 power distribution switches is intended for application where heavy capacitive loads and short -circuits are likely to be encountered. These devices incorporate 80 mΩ N-channel MOSFET high-side power switches for power-distribution systems that require multiple powers switches in a single package. Each switch is controlled by an independent logic enable input. Gate drive is provided by an internal charge pump designed to control the power-switch rise times and fall times to minimize current surges during switching. The charge pump requires no external components and allows operation from supplies as low as 2.7 V.

When the output load exceeds the current-limit threshold or a short is present, these devices limit the output current to a safe level by switching into a constant-current mode, pulling the overcurrent (\overline{OCx}) logic output low. A 10 ms deglitching circuit provides fault-blanking feature, preventing the OC_N pin to be asserted during hot-insertion or short spikes of overcurrent conditions.

When continuous heavy overloads and short-circuits increase the power dissipation in the switch, causing the junction temperature to rise, a thermal protection circuit shuts off the switch to prevent damage. Recovery from a thermal shutdown is automatic once the device has cooled sufficiently. Internal circuitry ensures the switch remains off until valid input voltage is present. These power-distribution switches are designed to current limit at 0.9 A.

3 Pin connections

Figure 2. Pin connections (top view)

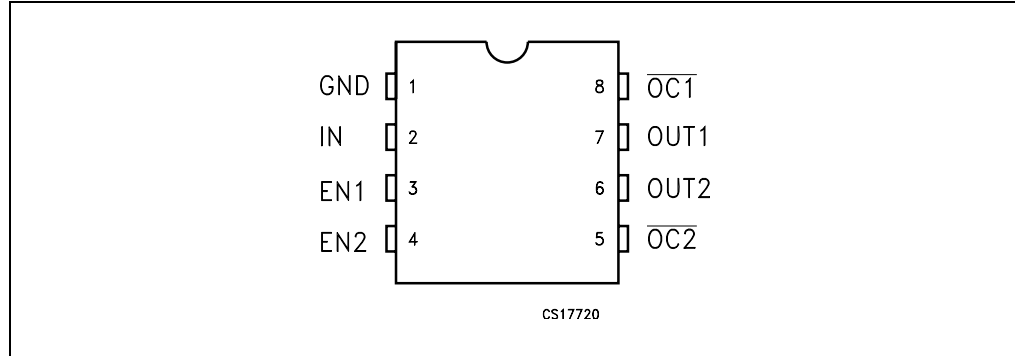

Table 2. Pin functions

Pin	Symbol	Description
1	GND	Ground
2	IN	Input voltage
3	EN1	Enable input. Logic high turns on power switch IN-OUT1.
4	EN2	Enable input. Logic high turns on power switch IN-OUT2.
5	OC2	Overcurrent. Logic output active low IN-OUT2.
6	OUT2	Power switch output
7	OUT1	Power switch output
8	OC1	Overcurrent. Logic output active Low IN-OUT2.

4 Electrical ratings

4.1 Absolute maximum ratings

Stressing the device above the rating listed in the “Absolute Maximum Ratings” table may cause permanent damage to the device. These are stress ratings only and operation of the device at these or any other conditions above those indicated in the Operating sections of this specification is not implied. Exposure to Absolute Maximum Rating conditions for extended periods may affect device reliability. Refer also to the STMicroelectronics™ SURE program and other relevant quality documents.

Table 3. Absolute maximum ratings

Symbol	Parameter	Value	Unit
V_I	Input voltage range ⁽¹⁾	-0.3 to 6	V
V_O	Output voltage range ⁽¹⁾	-0.3 - ($V_I + 0.3$)	V
V_{IENX}	EN Input voltage range	-0.3 to 6	V
I_O	Continuous output current	Internally limited	
ESD	Electrostatic discharge	2	kV
T_J	Junction operating temperature	-40 to 125	°C

1. All voltages are referred to GND.

4.2 Recommended operating conditions

Table 4. Recommended operating conditions

Symbol	Parameter	Min	Typ	Max	Unit
V_I	Input voltage range ⁽¹⁾	2.7		5.5	V
V_O	Output voltage range ⁽¹⁾	0		5.5	V
I_O	Continuous output current (per switch)	0		500	mA

1. All voltages are referred to GND.

5 Electrical characteristics

$V_I = 5.5\text{ V}$, $I_O = \text{rated current}$, $V_{IEN} = V_I$, $T_J = 25\text{ }^\circ\text{C}$, unless otherwise specified. (See [Note 1 on page 8](#)).

Table 5. Power switch electrical characteristics

Symbol	Parameter	Test conditions	Min	Typ	Max	Unit
$R_{DS(on)}$	Static drain-source ON-state resistance	$V_I = 5\text{ V}$ $I_O = 0.5\text{ A}$		80	100	m Ω
		$V_I = 5\text{ V}$ $I_O = 0.5\text{ A}$, $T_J = 85\text{ }^\circ\text{C}$		90	120	
		$V_I = 5\text{ V}$ $I_O = 0.5\text{ A}$, $T_J = 125\text{ }^\circ\text{C}$		100	135	
		$V_I = 3.3\text{ V}$ $I_O = 0.5\text{ A}$		90	125	
		$V_I = 3.3\text{ V}$ $I_O = 0.5\text{ A}$, $T_J = 85\text{ }^\circ\text{C}$		110	145	
		$V_I = 3.3\text{ V}$ $I_O = 0.5\text{ A}$, $T_J = 125\text{ }^\circ\text{C}$		120	160	
t_r	Output rise time	$V_I = 5.5\text{ V}$	$R_L = 10\text{ }\Omega$, $C_L = 1\text{ }\mu\text{F}$	2.5		ms
		$V_I = 2.7\text{ V}$		3		
t_f	Output fall time	$V_I = 5.5\text{ V}$		0.3		ms
		$V_I = 2.7\text{ V}$		0.2		

Table 6. Enable Input \overline{ENx} characteristics

Symbol	Parameter	Test conditions	Min	Typ	Max	Unit
V_{IH}	High level input voltage	$V_I = 2.7\text{ to }5.5\text{ V}$	2			V
V_{IL}	Low level input voltage	$V_I = 4.5\text{ to }5.5\text{ V}$			0.8	V
		$V_I = 2.7\text{ to }4.5\text{ V}$			0.4	
I_I	Input current	$V_{IENx} = 0\text{ V}$ or V_I	-0.5		0.5	μA
t_{on}	Turn-on time	$R_L = 10\text{ }\Omega$ $C_L = 100\text{ }\mu\text{F}$			20	ms
t_{off}	Turn-off time	$R_L = 10\text{ }\Omega$ $C_L = 100\text{ }\mu\text{F}$			40	ms

Table 7. Current limit characteristics

Symbol	Parameter	Test conditions	Min	Typ	Max	Unit
I_{OS}	Short-circuit output current	$V_I = 5\text{ V}$, OUT connected to GND, device enabled into short-circuit	0.7	1	1.3	A

Table 8. Supply current characteristics

Symbol	Parameter	Test conditions	Min	Typ	Max	Unit
I_{SOL}	Current low level output	$V_{IENX} = V_I$, no load,		0.025	1	μA
		$V_{IENX} = V_I$, no load, $T_J = -40$ to 125 °C			10	
I_{SOH}	Current low high output	$V_{IENX} = 0$, no load,		70	90	μA
		$V_{IENX} = 0$, no load, $T_J = -40$ to 125 °C			100	
I_L	Output leakage current	$V_{IENX} = V_I$, output connected to GND, $T_J = -40$ to 125 °C			10	μA

Table 9. Undervoltage characteristics

Symbol	Parameter	Test conditions	Min	Typ	Max	Unit
V_{IL}	Low level input voltage		2		2.5	V
V_{HYS}	Hysteresis			100		mV

Table 10. Overcurrent (\overline{OC}) characteristics

Symbol	Parameter	Test conditions	Min	Typ	Max	Unit
I_{SINK}	Sink current	$V_O = 5$ V	10			mA
V_O	Output low voltage	$I_O = 5$ mA			0.5	V
I_{OFF}	OFF-state current	$V_O = 5$ V $V_O = 3.3$ V			1	μA
T_{FB}	Fault-blanking period	$V_I = 5.5$ V, $T_J = 25$ °C (See Note 2 and Note 3)	2	10		ms

- Note: 1 Pulse testing techniques maintain junction temperature close to ambient temperature: thermal effect must be taken into account separately.
- 2 Specified by design, not production tested.
- 3 Guaranteed by design.

Figure 3. Test circuit

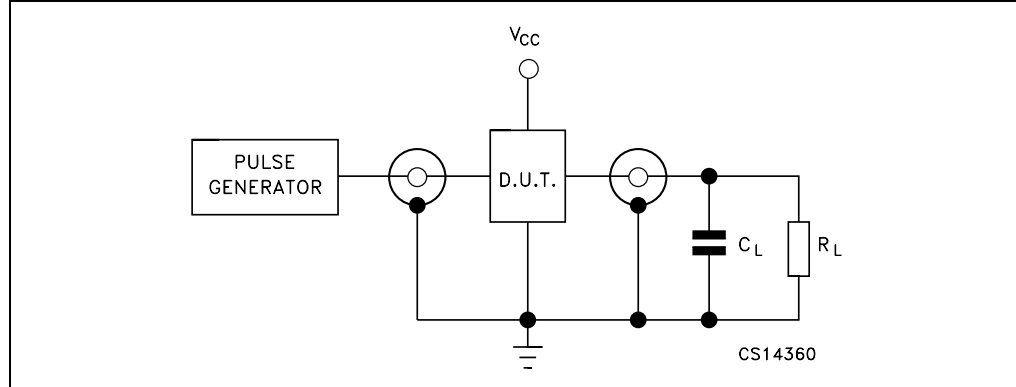
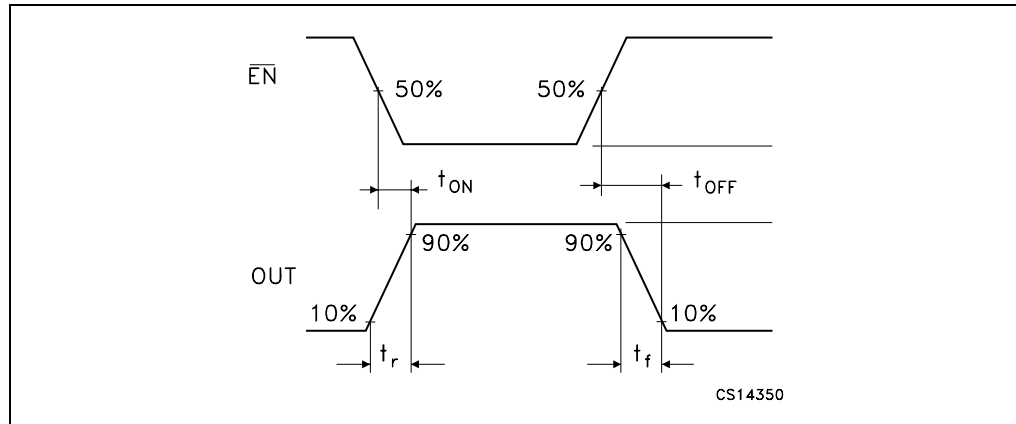
Figure 4. Waveform - propagation delays ($f = 1$ MHz; 50% duty cycle)

6 Package mechanical data

In order to meet environmental requirements, ST offers these devices in different grades of ECOPACK[®] packages, depending on their level of environmental compliance. ECOPACK[®] specifications, grade definitions and product status are available at: www.st.com. ECOPACK[®] is an ST trademark.

Figure 5. SO-8 package outline

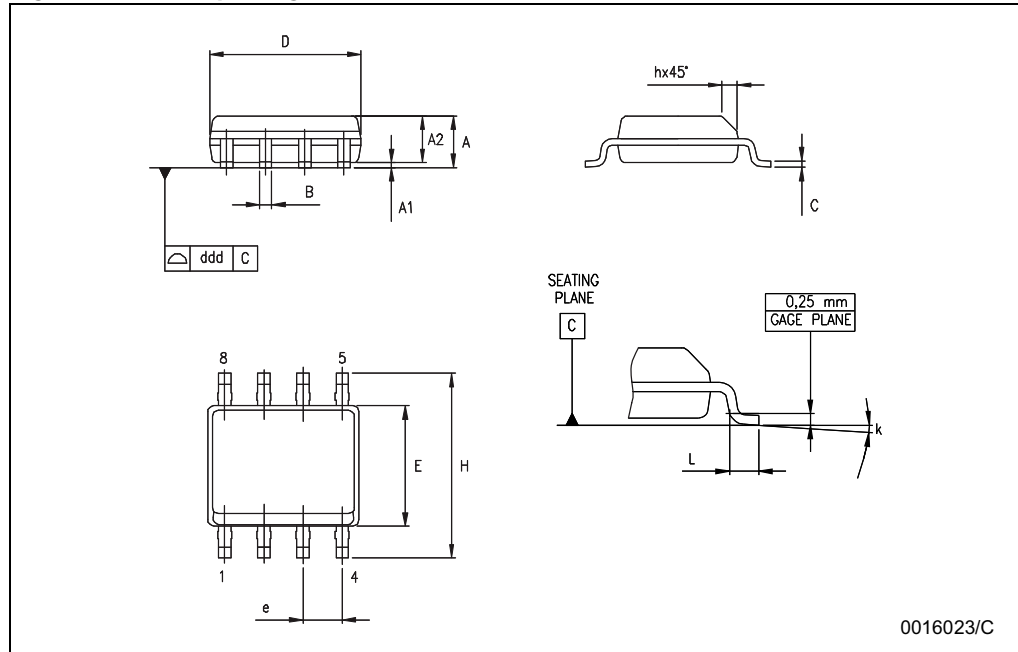

Table 11. SO8 - mechanical data

Symbol	Millimeters			inches		
	Min	Typ	Max	Min	Typ	Max
A	1.35		1.75	0.053		0.069
A1	0.10		0.25	0.004		0.010
A2	1.10		1.65	0.043		0.065
B	0.33		0.51	0.013		0.020
C	0.19		0.25	0.007		0.010
D	4.80		5.00	0.189		0.197
E	3.80		4.00	0.15		0.157
e		1.27			0.050	
H	5.80		6.20	0.228		0.244
h	0.25		0.50	0.010		0.020
L	0.40		1.27	0.016		0.050
k	8° (max.)					
ddd			0.10			0.004

Figure 6. Tape and reel SO-8 package outline

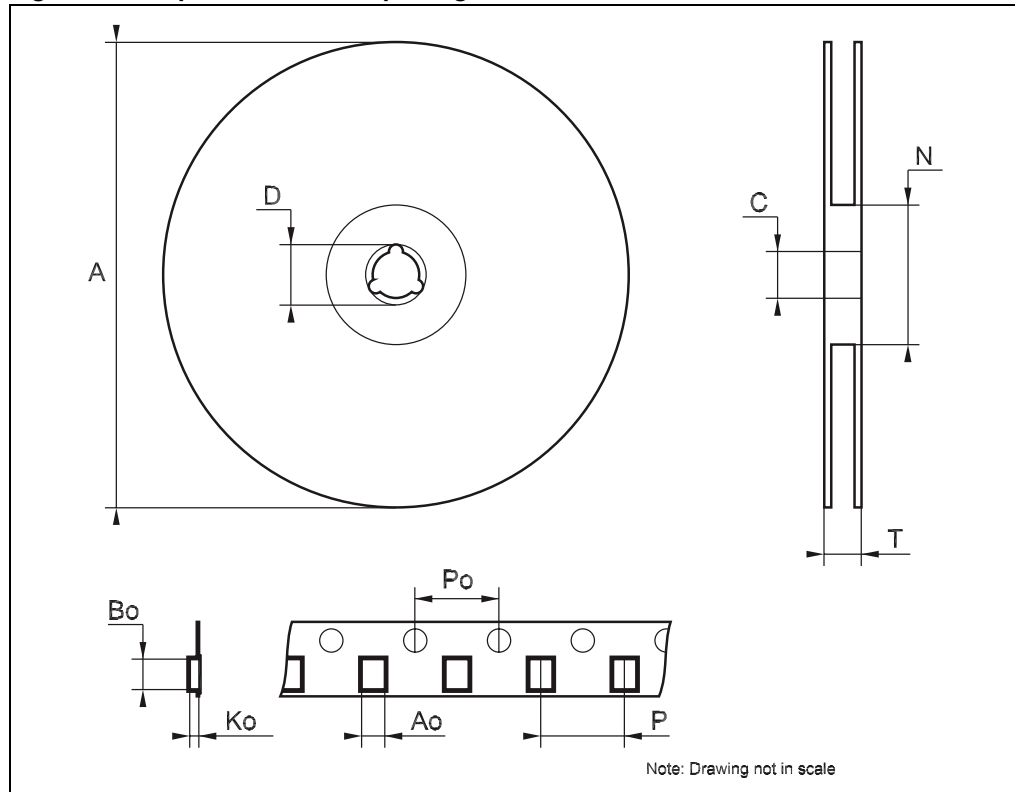

Table 12. Tape and reel SO-8 mechanical data

Symbol	Millimeters			inches		
	Min	Typ	Max	Min	Typ	Max
A			330			12.992
C	12.8		13.2	0.504		0.519
D	20.2			0.795		
N	60			2.362		
T			22.4			0.882
A0	8.1		8.5	0.319		0.335
B0	5.5		5.9	0.216		0.232
K0	2.1		2.3	0.082		0.090
P0	3.9		4.1	0.153		0.161
P	7.9		8.1	0.311		0.319

7 Revision history

Table 13. Revision history

Date	Revision	Changes
13-Jul-2005	2	Add bullet on pag. 1, add paragraph in the description on pag. 1 and add row T _{FB} on Table 10.
30-May-2007	3	Updated features in cover page, document reformatted
24-Nov-2010	4	Document reformatted, added "Not Recommended for New Design" and <i>Note 1</i> below <i>Table 1</i> , corrected typo in <i>Features</i> , <i>Section 1</i> , <i>Table 2</i> to <i>Table 10</i> , title of <i>Figure 4</i> , updated <i>Table 1</i> , <i>Section 4.1</i> , <i>Section 5</i> , ECOPACK [®] text in <i>Section 6</i> and <i>Table 11</i> .

Please Read Carefully:

Information in this document is provided solely in connection with ST products. STMicroelectronics NV and its subsidiaries ("ST") reserve the right to make changes, corrections, modifications or improvements, to this document, and the products and services described herein at any time, without notice.

All ST products are sold pursuant to ST's terms and conditions of sale.

Purchasers are solely responsible for the choice, selection and use of the ST products and services described herein, and ST assumes no liability whatsoever relating to the choice, selection or use of the ST products and services described herein.

No license, express or implied, by estoppel or otherwise, to any intellectual property rights is granted under this document. If any part of this document refers to any third party products or services it shall not be deemed a license grant by ST for the use of such third party products or services, or any intellectual property contained therein or considered as a warranty covering the use in any manner whatsoever of such third party products or services or any intellectual property contained therein.

UNLESS OTHERWISE SET FORTH IN ST'S TERMS AND CONDITIONS OF SALE ST DISCLAIMS ANY EXPRESS OR IMPLIED WARRANTY WITH RESPECT TO THE USE AND/OR SALE OF ST PRODUCTS INCLUDING WITHOUT LIMITATION IMPLIED WARRANTIES OF MERCHANTABILITY, FITNESS FOR A PARTICULAR PURPOSE (AND THEIR EQUIVALENTS UNDER THE LAWS OF ANY JURISDICTION), OR INFRINGEMENT OF ANY PATENT, COPYRIGHT OR OTHER INTELLECTUAL PROPERTY RIGHT.

UNLESS EXPRESSLY APPROVED IN WRITING BY AN AUTHORIZED ST REPRESENTATIVE, ST PRODUCTS ARE NOT RECOMMENDED, AUTHORIZED OR WARRANTED FOR USE IN MILITARY, AIR CRAFT, SPACE, LIFE SAVING, OR LIFE SUSTAINING APPLICATIONS, NOR IN PRODUCTS OR SYSTEMS WHERE FAILURE OR MALFUNCTION MAY RESULT IN PERSONAL INJURY, DEATH, OR SEVERE PROPERTY OR ENVIRONMENTAL DAMAGE. ST PRODUCTS WHICH ARE NOT SPECIFIED AS "AUTOMOTIVE GRADE" MAY ONLY BE USED IN AUTOMOTIVE APPLICATIONS AT USER'S OWN RISK.

Resale of ST products with provisions different from the statements and/or technical features set forth in this document shall immediately void any warranty granted by ST for the ST product or service described herein and shall not create or extend in any manner whatsoever, any liability of ST.

ST and the ST logo are trademarks or registered trademarks of ST in various countries.

Information in this document supersedes and replaces all information previously supplied.

The ST logo is a registered trademark of STMicroelectronics. All other names are the property of their respective owners.

© 2010 STMicroelectronics - All rights reserved

STMicroelectronics group of companies

Australia - Belgium - Brazil - Canada - China - Czech Republic - Finland - France - Germany - Hong Kong - India - Israel - Italy - Japan - Malaysia - Malta - Morocco - Philippines - Singapore - Spain - Sweden - Switzerland - United Kingdom - United States of America

www.st.com