

TB6581H/HG

3-Phase Full-Wave Sine-Wave PWM Brushless Motor Controller

The TB6581H/HG is a high-voltage PWM BLDC motor driver. The product integrates the TB6551F/FG sine-wave controller and the TPD4103AK high-voltage driver in a single package ("2-in-1"). It is designed to change the speed of a BLDC directly motor by using a speed control signal (analog) from a microcontroller.

Features

- A sine wave PWM drive controller and a high-voltage driver integrated in a single package.
- IGBTs arranged in three half-bridge units
- Triangle wave generator (carrier frequency = $f_{osc}/254$ (Hz))
- Dead-time insertion (1.9 μ s)
- High-side bootstrap supply
- Bootstrap diode
- Overcurrent protection, thermal shutdown, and undervoltage lockout
- On-chip regulator ($V_{reg} = 7$ V (typ.), 30 mA (max), $V_{refout} = 5$ V (typ.), 30 mA (max))
- Operating power supply voltage range: $V_{CC} = 13.5\sim 16.5$ V
- Motor power supply operating voltage range: $V_B = 50\sim 400$ V

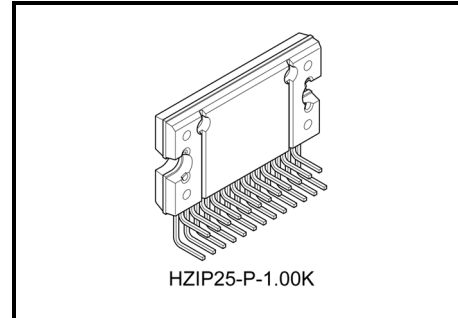

Weight:
HZIP25-P-1.00K: 7.7 g (typ.)

TB6581HG:

TB6581HG is a Pb-free product.

The following conditions apply to solderability:

*Solderability

1. Use of Sn-37Pb solder bath
 - *solder bath temperature = 230°C
 - *dipping time = 5 seconds
 - *number of times = once
 - *use of R-type flux
2. Use of Sn-3.0Ag-0.5Cu solder bath
 - *solder bath temperature = 245°C
 - *dipping time = 5 seconds
 - *the number of times = once
 - *use of R-type flux

Pin Description

Pin No.	Symbol	Description	Function
1	PGND	Grounding pin	Power ground
2	VREG	Reference voltage output	Connected to pin 5. 7 V (typ.), 30 mA (max)
3	IS	IGBT emitter pin	For connecting a current sensing resistor to ground.
4	NC	Not connected	This pin is left open and can be used as a jumper on a PCB.
5	V _{CC7}	Signal control power supply pin	Connected to pin 2. The control stage operating voltage: V _{CC} = 6 to 10 V
6	V _{refout}	Reference voltage output	5 V (typ.), 30 mA (max) For connecting a bypass capacitor for internal V _{DD} .
7	Idc	Current limit input	DC link input Reference potential of 0.5 V. This pin has a filter (≈ 1 μs).
8	SGND	Grounding pin	Signal ground
9	X _{in}	Clock input	These pins have a feedback resistor. For connecting to a crystal oscillator.
10	X _{out}	Clock output	
11	Ve	Voltage command input	This pin has a pull-down resistor.
12	HU	U-phase position sensing input	If the position sensing inputs are all HIGH or LOW, the outputs are turned off. This pin has a pull-up resistor.
13	HV	V-phase position sensing input	
14	HW	W-phase position sensing input	
15	LA	Lead angle control input	0 to 58° in 32 steps
16	FG	FG signal output	This pin drives three pulses per rotation.
17	REV	Reverse rotation signal	For reverse rotation detection.
18	BSU	Bootstrap supply (phase U)	For connecting a bootstrap capacitor to the U-phase output.
19	U	U-phase output pin	—
20	BSV	Bootstrap supply (phase V)	For connecting a bootstrap capacitor to the V-phase output.
21	V	V-phase output pin	—
22	BSW	Bootstrap supply (phase W)	For connecting a bootstrap capacitor to the W-phase output.
23	W	W-phase output pin	—
24	VB	High-voltage power supply pin	Power supply pin for driving a motor.
25	V _{CC15}	Power supply pin for the power stage	Power stage operating range: V _{CC} = 15 V

Pin Assignment

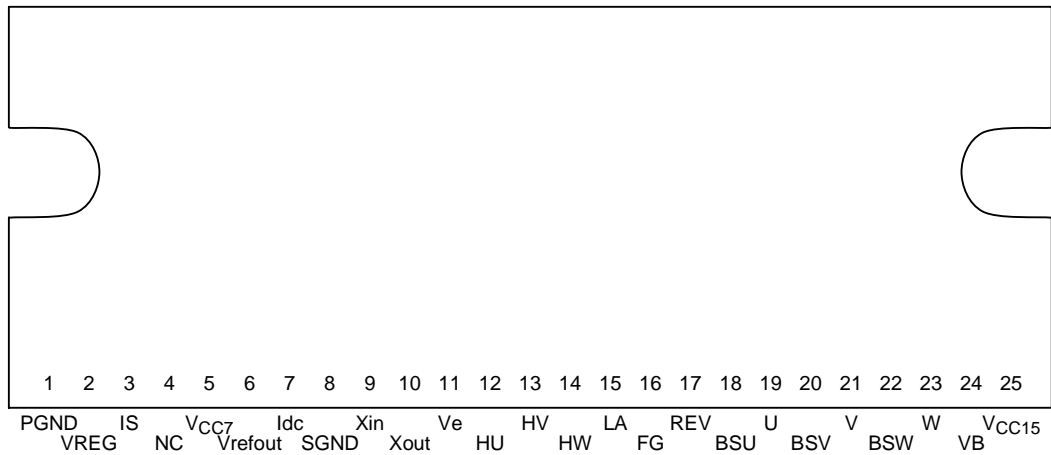

Absolute Maximum Ratings (Ta = 25°C)

Characteristics	Symbol	Rating	Unit
Power supply voltage	VCC7	12	V
	VCC15	18	
	VB	500	
Input voltage	V _{in} (1)	-0.3 to VCC1 (Note 1)	V
	V _{in} (2)	-0.3 to 5.5 (Note 2)	
PWM output current	I _{OUT}	2 (Note 3)	A
Power dissipation	P _D	40 (Note 4)	W
Operating temperature	T _{opr}	-30 to 115 (Note 5)	°C
Storage temperature	T _{stg}	-50 to 150	°C

Note 1: V_{in} (1) pin: V_e, LA

Note 2: V_{in} (2) pin: I_{dc}, HU, HV, HW

Note 3: Apply pulse

Note 4: Package thermal resistance (θ j-c = 1°C/W) with an infinite heat sink at Ta = 25°C

Note 5: The operating temperature range is determined according to the P_D MAX – Ta characteristics.

Recommended operating conditions (Ta = 25°C)

Characteristics	Symbol	Min	Typ.	Max	Unit
Power supply voltage	V _{CC7}	6	7	10	V
	V _{CC15}	13.5	15	16.5	
Crystal oscillator frequency	X _{in}	2	4	5	MHz
Motor power supply voltage	VB	50	280	400	V
Output current	I _{out}	—	1	2	A

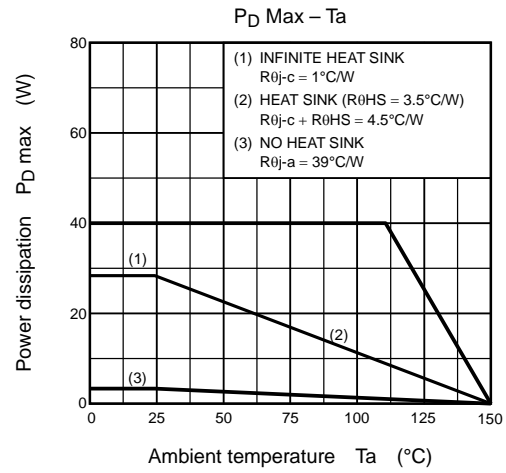

Electrical Characteristics (Ta = 25°C)

Characteristics	Symbol	Test Condition	Min	Typ.	Max	Unit	
Current dissipation	I_B	$V_B = 400\text{ V}$	—	0.1	0.5	mA	
	I_{CC15}	$V_{reg} = \text{OPEN}, V_{CC} = 15\text{ V}$	—	1.1	3		
	I_{CC7}	$V_{refout} = \text{OPEN}, V_{CC} = 7\text{ V}$	—	3	6		
	$I_{BS (ON)}$	$V_{BS} = 15\text{ V}, \text{high-side ON}$	—	260	410	μA	
	$I_{BS (OFF)}$	$V_{BS} = 15\text{ V}, \text{high-side OFF}$	—	230	370		
Input current	$I_{in (LA)}$	$V_{in} = 5\text{ V}, \text{LA}$	—	25	50	μA	
	$I_{in (V_e)}$	$V_{in} = 5\text{ V}, V_e$	—	35	70		
	$I_{in (Hall)}$	$V_{in} = 0\text{ V}, \text{HU, HV, HW}$	-50	-25	—		
Input voltage	$V_{in (Hall)}$	HIGH	HU, HV, HW	$V_{refout-1}$	—	V_{refout}	V
		LOW		—	—	0.8	
	$V_{in (V_e)}$	HIGH	PWM Duty 100%	5.1	5.4	5.7	
		Middle	Refresh → Start motor operation	1.8	2.1	2.4	
LOW		Turned-off → Refresh	0.7	1.0	1.3		
Input hysteresis voltage	V_H	HU, HV, HW (Note 6)	—	0.3	—	V	
Input delay time	V_{DT}	HU, HV, HW $X_{in} = 4.19\text{ MHz}$	—	4.0	—	μs	
	V_{DC}	I_{dc} $X_{in} = 4.19\text{ MHz}$	—	4.0	—		
Output saturation voltage	V_{CEsatH}	$V_{CC} = 15\text{ V}, I_C = 0.5\text{ A}$	—	2.4	3	V	
	V_{CEsatL}	$V_{CC} = 15\text{ V}, I_C = 0.5\text{ A}$	—	2.4	3		
Output voltage	$V_{FG (H)}$	$I_{OUT} = 1\text{ mA}$ FG	$V_{refout-1.0}$	$V_{refout-0.2}$	—	V	
	$V_{FG (L)}$	$I_{OUT} = -1\text{ mA}$ FG	—	0.2	1.0		
	V_{refout}	$I_{OUT} = 30\text{ mA}$ V_{refout}	4.5	5.0	5.5		
	V_{reg}	$I_{OUT} = 30\text{ mA}$	6.5	7	7.5		
FRD forward voltage	V_{FH}	$I_F = 0.5\text{ A}, \text{high-side}$	—	1.3	2.0	V	
	V_{FL}	$I_F = 0.5\text{ A}, \text{low-side}$	—	1.3	2.0		
BSD forward voltage	$V_F (BSD)$	$I_F = 500\text{ }\mu\text{A}$	—	0.9	1.2	V	
Current detection	V_{dc}	I_{dc}	0.47	0.5	0.53	V	
Thermal shutdown protection	TSD	(Note 7)	150	165	200	$^{\circ}\text{C}$	
	TSDhys		—	20	—		
V_{CC15} undervoltage protection for driver	$V_{CC15 (H)}$	Undervoltage positive-going threshold	10.5	11.5	12.5	V	
	$V_{CC15 (L)}$	Undervoltage negative-going threshold	10	11	12		
VBS undervoltage protection for driver	$V_{BS (H)}$	Undervoltage positive-going threshold	8.5	9.5	10.5	V	
	$V_{BS (L)}$	Undervoltage negative-going threshold	8	9	10		
V_{CC7} undervoltage protection for controller	$V_{CC7 (H)}$	Undervoltage positive-going threshold	4.2	4.5	4.8	V	
	$V_{CC7 (L)}$	Undervoltage negative-going threshold	3.7	4.0	4.3		
Output turn-on/-off delay time	t_{on}	$V_{BB} = 280\text{ V}, V_{CC} = 15\text{ V}, I_C = 0.5\text{ A}$	—	1.5	3	μs	
	t_{off}	$V_{BB} = 280\text{ V}, V_{CC} = 15\text{ V}, I_C = 0.5\text{ A}$	—	1.2	3		
Dead time	t_{dead}	$X_{in} = 4.19\text{ MHz}$	1.5	1.8	—	μs	
FRD reverse recovery time	t_{rr}	$V_{BB} = 280\text{ V}, V_{CC} = 15\text{ V}, I_C = 0.5\text{ A}$	—	200	—	ns	

Note 6 and Note 7: Toshiba does not implement testing before shipping.

Functional Description

1. Basic operation

The motor is driven by the square-wave turn-on signal based on a positional signal. When the positional signal reaches number of rotations $f = 5$ Hz or higher, the rotor position is estimated according to the positional signal and a modulation wave is generated. The modulation wave and the triangular wave are compared; then the sine-wave PWM signal is generated and the motor is driven.

From start to 5 Hz: When driven by square wave (120° turn-on) $f = f_{osc}/(2^{12} \times 32 \times 6)$

5 Hz~: When driven by sine-wave PWM (180° turn-on); when $f_{osc} = 4$ MHz, approx. 5 Hz

2. V_e voltage command input and bootstrap power supply

- (1) Voltage command input: When $V_e \leq 1.0$ V
U, V and W signals are stopped to protect IGBTs
- (2) Voltage command input: When 1.0 V $< V_e \leq 2.1$ V
The low-side IGBTs are turned on at a fixed frequency (carrier frequency) (duty cycle: 8%).
- (3) Voltage command input: When $V_e > 2.1$ V
The U, V and W signals are driven out during sine wave drive.
The low-side IGBTs are forced to on at fixed frequency (carrier frequency) during square-wave drive (duty cycle: 8%).

Note 1: At startup, the low-side IGBTs must be turned on for a fixed period at 1.0 V $< V_e \leq 2.1$ V to charge the high-side IGBT power supply.

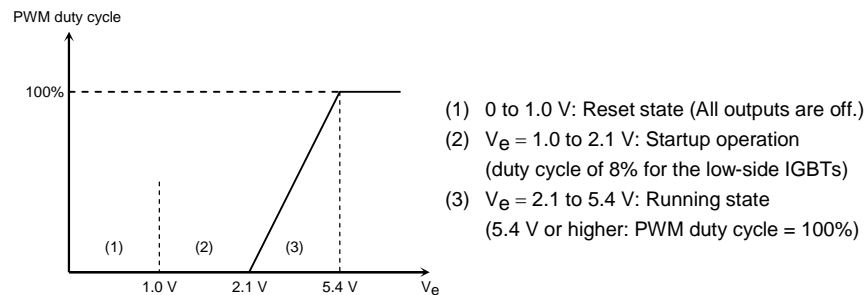

3. Dead time function: upper/lower transistor output off-time

When the motor is driven by sine-wave PWM, dead time is digitally generated inside the IC to prevent short circuit caused by the simultaneously turning on of upper and lower external power devices. When a square wave is generated in full-duty cycle mode, the dead time function is turned on to prevent a short circuit.

Internal Counter	T_{OFF}
$8/f_{osc}$	1.9 μ s

T_{OFF} values above are obtained when $f_{osc} = 4.19$ MHz.
 f_{osc} = reference clock (crystal oscillation)

4. Correcting the lead angle

The lead angle can be corrected in the turn-on signal range from 0 to 58° in relation to the induced voltage.

Analog input from LA pin (0 V to 5 V divided by 32)

0 V = 0°

5 V = 58° (when more than 5 V is input, 58°)

5. Setting the carrier frequency

This function sets the triangular wave cycle (carrier cycle) necessary for generating the PWM signal. (The triangular wave is used for forcibly turning on the lower transistor when the motor is driven by square wave.)

$$\text{Carrier cycle} = f_{osc}/252 \text{ (Hz)} \quad f_{osc} = \text{reference clock (crystal oscillation)}$$

6. Outputting the reverse rotation detection signal

This function detects the motor rotation direction every electrical angle of 360°. This function judges whether the actual direction of a rotating motor coincides with that of the internal reference voltage.

Actual Motor Rotating Direction	REV Pin	Drive Mode
CW (forward)	HIGH	Square waveform (120° turn-on mode)
CCW (reverse)	LOW	Sine-wave waveform (180° turn-on mode)

*: CW or CCW of the motor is determined by the direction of the Hall signal, which is specified in the timing chart on page 9.

*: When the REV pin is set to LOW, and the Hall signal is higher than 5 Hz, sine-wave drive mode is turned on.

7. Protecting input pin

(1) Overcurrent protection (Pin I_{dc})

When the DC-link-current exceeds the internal reference voltage, gate block protection is performed. Overcurrent protection is released for each carrier frequency.

Reference voltage = 0.5 V (typ.)

(2) Positional signal abnormality protection

Output is turned off when the positional signal is HHH or LLL; otherwise, it is restarted.

(3) Monitor protection for VCC7/ VCC15 low supply voltage

For power supply on/off outside the operating voltage range, the U, V and W drive outputs are turned off and the motor is stopped when there is a power supply fault.

< VCC7 >

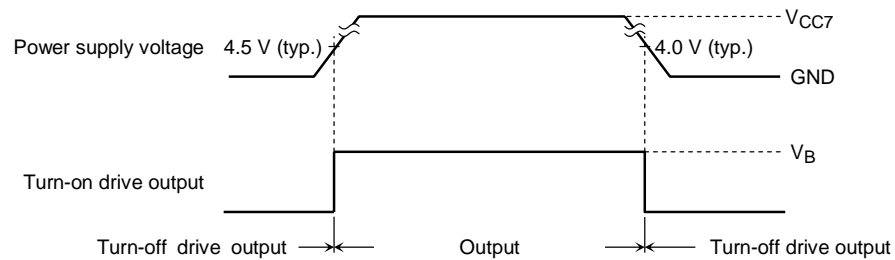

< VCC15 >

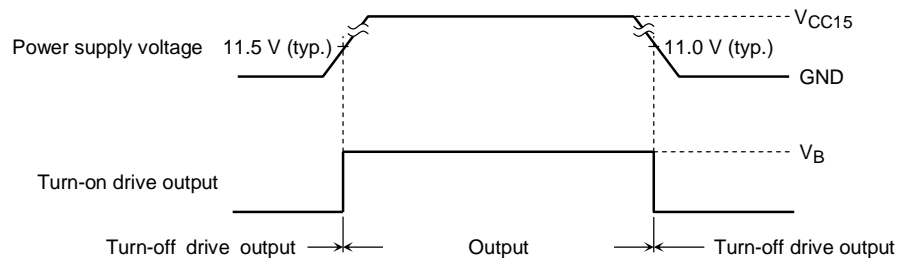

- (4) Monitor protection for VBS Bootstrap power supply
 When VBS power supply is lowered, the high-side IGBT is turned off.

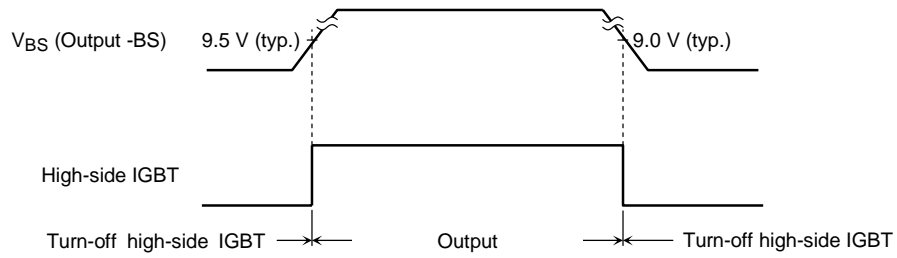

- (5) Overheat protection
 The overheat protection circuit will operate and all IGBTs will be turned off if the chip temperature becomes abnormally high due to internal or external heat generation.

$T_{SD} = 165^{\circ}\text{C}$ (typ.) $T_{SDhys} = 20^{\circ}\text{C}$ (typ.)

After the overheat protection circuit is turned on, the return temperature is 145°C (typ.).

Timing Chart

- CW (forward) mode (CW mode means that the Hall signal is input in the order shown below.)

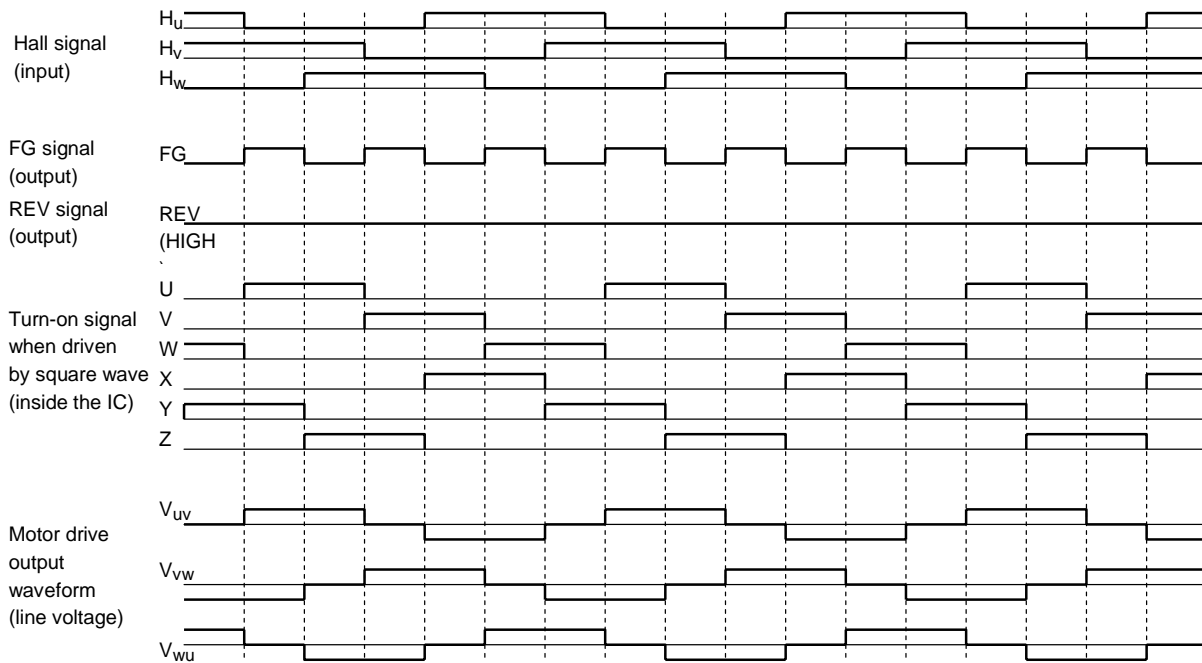

* The waveform of actual operation is the PWM

- CCW (reverse) mode (CCW mode means that the Hall signal is input in the order shown below.)

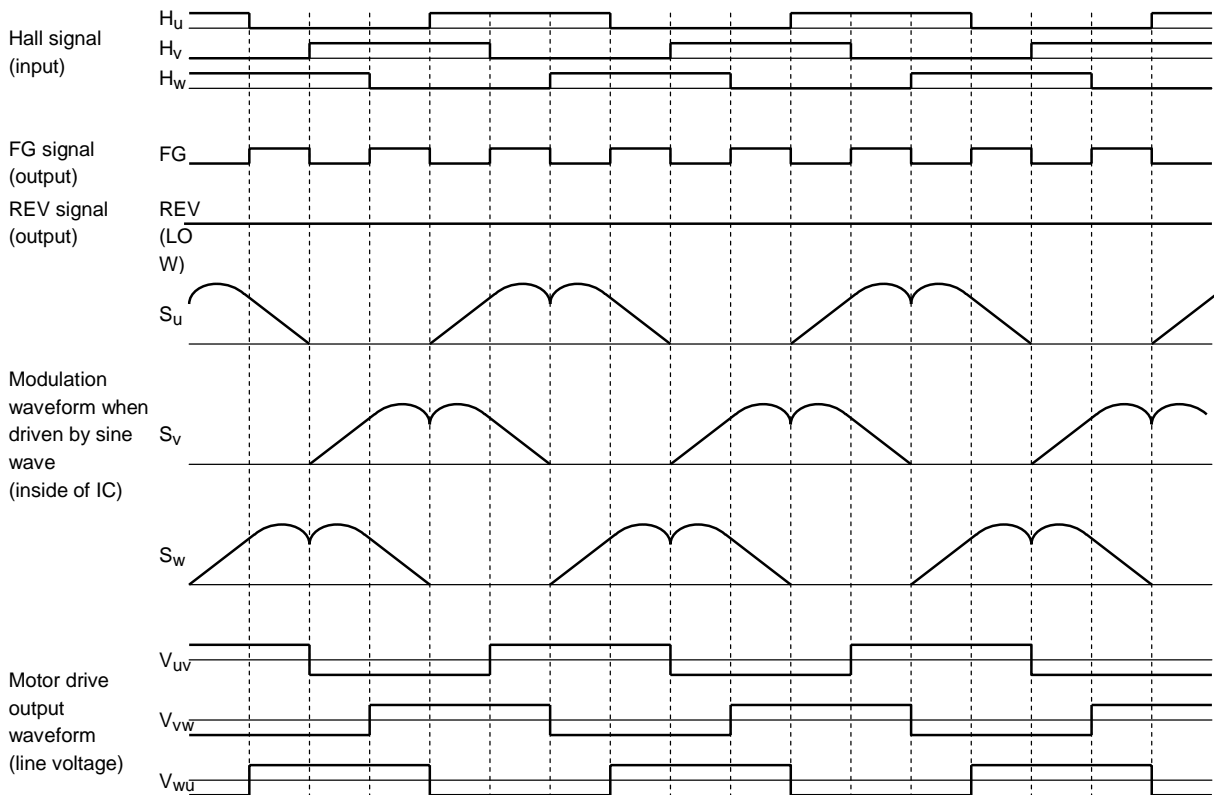

* The waveform of actual operation is the PWM

Example of Application Circuit

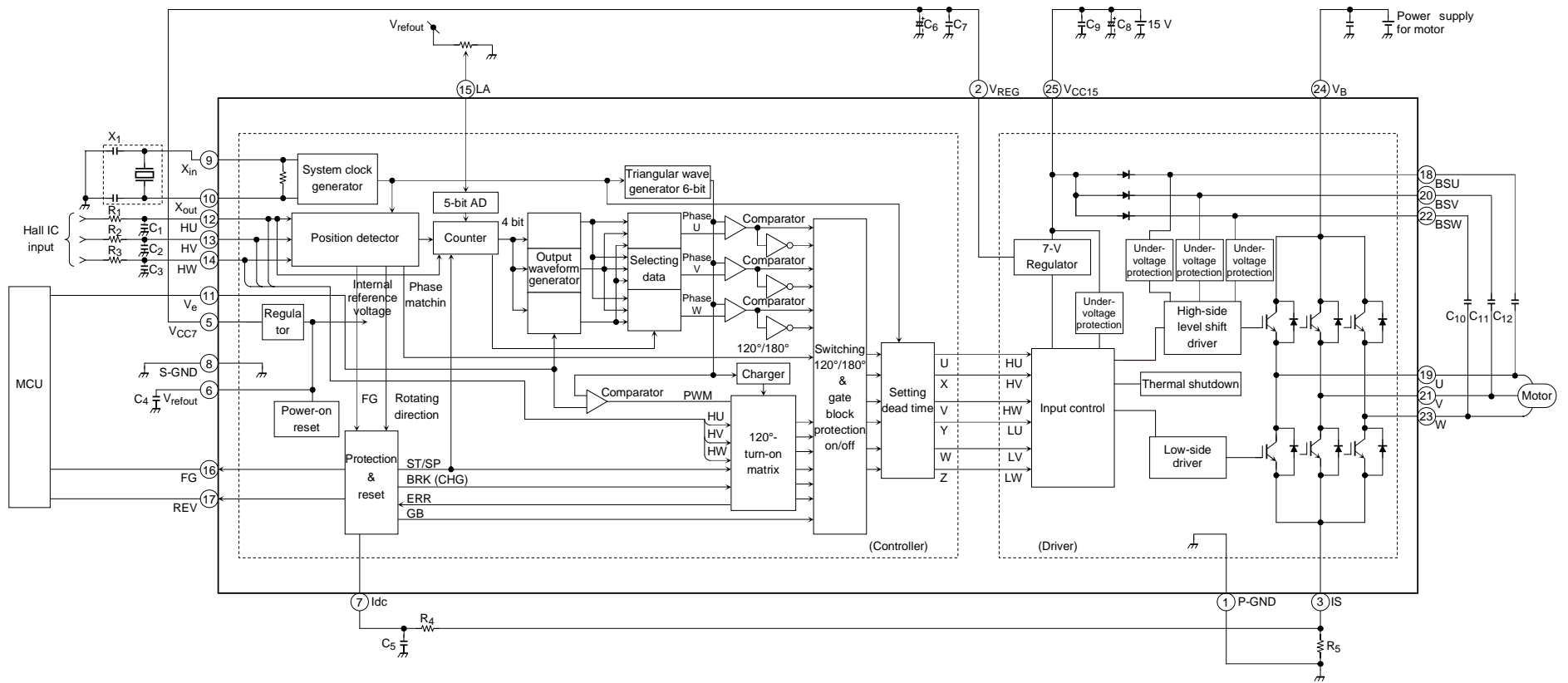

External Parts

Symbol	Purpose	Recommended value	Note
X ₁	Internal clock generation	4.19 MHz	(Note 1)
C ₁ , C ₂ , C ₃	Noise absorber	10 V/1000 pF	(Note 2)
R ₁ , R ₂ , R ₃		10 kΩ	
C ₄	V _{refout} oscillation protection	10 V/0.1 μF~1.0 μF	(Note 3)
C ₅	Noise absorber	10 V/1000pF	(Note 2)
R ₄		5.1 kΩ	
R ₅	Overcurrent detection	0.62 Ω ± 1% (1 W)	(Note 4)
C ₆	V _{REG} power supply stability	16 V/1.0 μF~10 μF	(Note 3)
C ₇		10 V/1000 pF	
C ₈	V _{CC15} power supply stability	25 V/0.1 μF	(Note 3)
C ₉		25 V/10 μF	
C ₁₀ , C ₁₁ , C ₁₂	Bootstrap capacitor	25 V/2.2 μF	(Note 5)

Note 1: For carrier frequency and dead time, connect a 4.19 MHz ceramic resonator.

Note 2: These parts are used as a low-pass filter for noise absorption. Test to confirm noise filtering, then set the filter time-constant.

Note 3: This part is used as a capacitor for power supply stability. Adjust the part to the application environment as required. When mounting, place it as close as possible to the base of the leads of this product to improve the noise elimination.

Note 4: This part is used to set the value for overcurrent detection. $I_{out(max)} = V_{dc} \div R_5$ ($V_{dc} = 0.5$ V (typ.))

Note 5: The required bootstrap capacitance value varies according to the motor drive conditions. The voltage stress for the capacitor is the value of V_{CC15}.

Other Precautions

Utmost care is necessary in the design of the output, V_{CC}, V_M, and GND lines since the IC may be destroyed by short-circuiting between outputs, air contamination faults, or faults due to improper grounding, or by short-circuiting between contiguous pins.

In turning on the power, first supply V_{cc15} and confirm its stability; then apply V_{cc7} and the driving input signal. V_{cc15} and V_B may be turned on in either order. In turning off the power, take care not to cut off the V_B line by relay while the motor is spinning. Doing so may cause the IC to break down by cutting the current-producing route for V_B.

The TB6581H/HG is sensitive to electrostatic discharge. Handle with care.

The product should be mounted by the solder-flow method. The preheating time is from 60 to 120 seconds at 150°C. The maximum heat is 260°C, to be applied within 10 seconds and as far as the lead stopper.

Package Dimensions

HZIP25-P-1.00K

Unit: mm

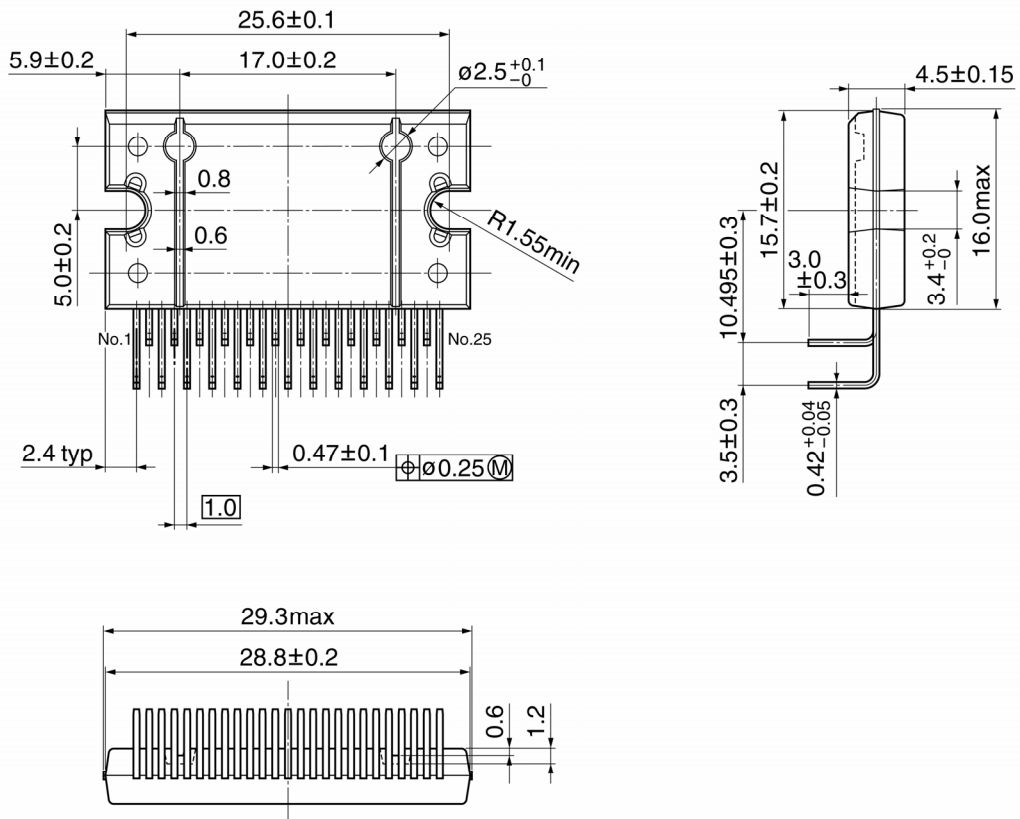

Weight: 7.7 g (typ.)

Notes on Contents

1. Block Diagrams

Some of the functional blocks, circuits, or constants in the block diagram may be omitted or simplified for explanatory purposes.

2. Equivalent Circuits

The equivalent circuit diagrams may be simplified or some parts of them may be omitted for explanatory purposes.

3. Timing Charts

Timing charts may be simplified for explanatory purposes.

4. Application Circuits

The application circuits shown in this document are provided for reference purposes only. Thorough evaluation is required, especially at the mass production design stage.

Toshiba does not grant any license to any industrial property rights by providing these examples of application circuits.

5. Test Circuits

Components in the test circuits are used only to obtain and confirm the device characteristics. These components and circuits are not guaranteed to prevent malfunction or failure from occurring in the application equipment.

IC Usage Considerations

Notes on handling of ICs

- [1] The absolute maximum ratings of a semiconductor device are a set of ratings that must not be exceeded, even for a moment. Do not exceed any of these ratings.
Exceeding the rating(s) may cause the device breakdown, damage or deterioration, and may result injury by explosion or combustion.
- [2] Use an appropriate power supply fuse to ensure that a large current does not continuously flow in case of over current and/or IC failure. The IC will fully break down when used under conditions that exceed its absolute maximum ratings, when the wiring is routed improperly or when an abnormal pulse noise occurs from the wiring or load, causing a large current to continuously flow and the breakdown can lead smoke or ignition. To minimize the effects of the flow of a large current in case of breakdown, appropriate settings, such as fuse capacity, fusing time and insertion circuit location, are required.
- [3] If your design includes an inductive load such as a motor coil, incorporate a protection circuit into the design to prevent device malfunction or breakdown caused by the current resulting from the inrush current at power ON or the negative current resulting from the back electromotive force at power OFF. IC breakdown may cause injury, smoke or ignition.
Use a stable power supply with ICs with built-in protection functions. If the power supply is unstable, the protection function may not operate, causing IC breakdown. IC breakdown may cause injury, smoke or ignition.
- [4] Do not insert devices in the wrong orientation or incorrectly.
Make sure that the positive and negative terminals of power supplies are connected properly. Otherwise, the current or power consumption may exceed the absolute maximum rating, and exceeding the rating(s) may cause the device breakdown, damage or deterioration, and may result injury by explosion or combustion.
In addition, do not use any device that is applied the current with inserting in the wrong orientation or incorrectly even just one time.

Points to remember on handling of ICs**(1) Over current Protection Circuit**

Over current protection circuits (referred to as current limiter circuits) do not necessarily protect ICs under all circumstances. If the Over current protection circuits operate against the over current, clear the over current status immediately.

Depending on the method of use and usage conditions, such as exceeding absolute maximum ratings can cause the over current protection circuit to not operate properly or IC breakdown before operation. In addition, depending on the method of use and usage conditions, if over current continues to flow for a long time after operation, the IC may generate heat resulting in breakdown.

(2) Thermal Shutdown Circuit

Thermal shutdown circuits do not necessarily protect ICs under all circumstances. If the thermal shutdown circuits operate against the over temperature, clear the heat generation status immediately.

Depending on the method of use and usage conditions, such as exceeding absolute maximum ratings can cause the thermal shutdown circuit to not operate properly or IC breakdown before operation.

(3) Heat Radiation Design

In using an IC with large current flow such as power amp, regulator or driver, please design the device so that heat is appropriately radiated, not to exceed the specified junction temperature (T_j) at any time and condition. These ICs generate heat even during normal use. An inadequate IC heat radiation design can lead to decrease in IC life, deterioration of IC characteristics or IC breakdown. In addition, please design the device taking into consideration the effect of IC heat radiation with peripheral components.

(4) Back-EMF

When a motor rotates in the reverse direction, stops or slows down abruptly, a current flow back to the motor's power supply due to the effect of back-EMF. If the current sink capability of the power supply is small, the device's motor power supply and output pins might be exposed to conditions beyond maximum ratings. To avoid this problem, take the effect of back-EMF into consideration in system design.

RESTRICTIONS ON PRODUCT USE

060116EBA

- The information contained herein is subject to change without notice. 021023_D
- TOSHIBA is continually working to improve the quality and reliability of its products. Nevertheless, semiconductor devices in general can malfunction or fail due to their inherent electrical sensitivity and vulnerability to physical stress. It is the responsibility of the buyer, when utilizing TOSHIBA products, to comply with the standards of safety in making a safe design for the entire system, and to avoid situations in which a malfunction or failure of such TOSHIBA products could cause loss of human life, bodily injury or damage to property.
In developing your designs, please ensure that TOSHIBA products are used within specified operating ranges as set forth in the most recent TOSHIBA products specifications. Also, please keep in mind the precautions and conditions set forth in the "Handling Guide for Semiconductor Devices," or "TOSHIBA Semiconductor Reliability Handbook" etc. 021023_A
- The TOSHIBA products listed in this document are intended for usage in general electronics applications (computer, personal equipment, office equipment, measuring equipment, industrial robotics, domestic appliances, etc.). These TOSHIBA products are neither intended nor warranted for usage in equipment that requires extraordinarily high quality and/or reliability or a malfunction or failure of which may cause loss of human life or bodily injury ("Unintended Usage"). Unintended Usage include atomic energy control instruments, airplane or spaceship instruments, transportation instruments, traffic signal instruments, combustion control instruments, medical instruments, all types of safety devices, etc. Unintended Usage of TOSHIBA products listed in this document shall be made at the customer's own risk. 021023_B
- The products described in this document shall not be used or embedded to any downstream products of which manufacture, use and/or sale are prohibited under any applicable laws and regulations. 060106_Q
- The information contained herein is presented only as a guide for the applications of our products. No responsibility is assumed by TOSHIBA for any infringements of patents or other rights of the third parties which may result from its use. No license is granted by implication or otherwise under any patent or patent rights of TOSHIBA or others. 021023_C
- The products described in this document are subject to the foreign exchange and foreign trade laws. 021023_E