

**ANALOG
PRODUCTS**

**MPC17511
FACT SHEET**

**POWER ICs
H-BRIDGE**

Freescale Semiconductor, Inc.

17511 0.46 Ω (TYP) H-BRIDGE MOTOR DRIVER IC

The 17511 is a monolithic H-Bridge that is ideal in portable electronic applications to control various micro DC-motors found in Single Lens Reflex Cameras and Optical Disc Drives (MO, DVD, and CD).

The 17511 is a 6.8 V H-Bridge motor driver with enable and tri-state bridge control and an additional output for controlling an external MOSFET via a parallel MCU interface (3.0 V and 5.0 V compatible logic). The IC can drive various types of micro motors with low loss via parallel drive. The part uses very efficient drivers designed for PWM control frequency up to 200 kHz for high-speed drive and independent input/output circuitry.

The 17511 has a low "ON" resistance of 0.6 Ω (max). The output devices use an integrated charge pump and level shifter for gate drive voltages, with integrated shoot through current protection circuit and undervoltage circuit detector. The bridge operates in four output control modes: Forward, Reverse, Brake, and Tri-state (Open).

APPLICATIONS

- Portable Electronics
- Single Lens Camera
- Optical Disc Drive (MO, DVD, and CD)

CUSTOMER BENEFITS

- Easy MCU interfacing and control of a single H-Bridge
- Undervoltage detection to prevent erratic operation
- High PWM rate for enhanced motor control
- Output protected H-Bridge operation to 6.8 V @ 1.0 A cont. PWM to 200 kHz
- Low profile package for portable designs
- Integral charge pump for a simpler system
- TSWITCH output for driving an external MOSFET
- Low quiescent current
- Reduced design time

Simplified Application Diagram

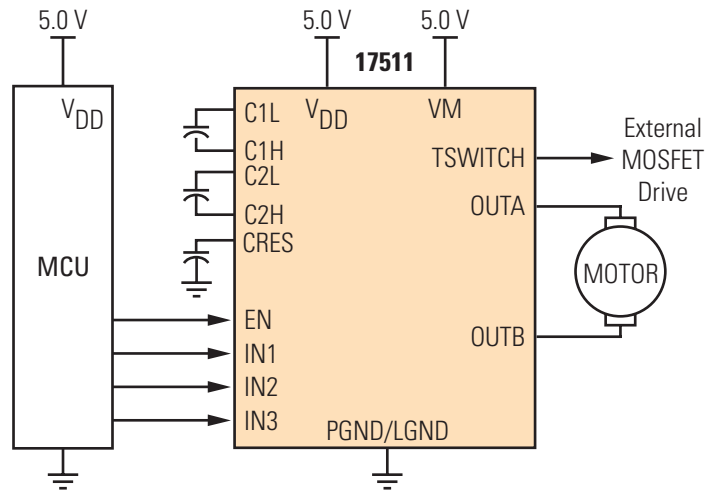



Performance	Typical Values
Outputs	1 ch
Output Current	1.0 A (DC), 3.0 A (Peak)
Motor Operating Voltage	2.0 V – 6.8 V
Logic Operating Voltage	2.7 V – 5.7 V
Input PWM	200 kHz
Operating Temp	-20°C ≤ T _A ≤ 65°C

**For More Information On This Product,
Go to: www.freescale.com**

FEATURES

- Low $R_{DS(ON)}$ 0.46 Ω (typ)
- Output current 1.0 A (DC), 3.0 A (peak)
- Shoot-through current protection circuit
- PWM control input frequency 200 kHz
- External MOSFET control circuit
- Charge pump circuit
- Additional devices available for comparison in Analog Selector Guide SG1002/D

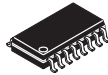
Protection	Detect	Limiting	Shut Down
Undervoltage	•		•

Ordering Information	Package	Ship Method	Motorola Part Number
	16 VMFP	Rail T/R	**17511EV **17511EVEL
	24 QFN	Rail T/R	**17511EP **17511EPR2

Data Sheet Order Number MPC17511/D
Contact Sales for Evaluation Kit Availability

**Prefix Index:
PPC = Eng Samples; XPC = In Qual; MPC = Production

QUESTIONS

- Are you working with portable electronic battery powered applications?
- Do you need to control a micro brush DC-motor in a 3.0 V or 5.0 V logic system?
- Are you designing a brush DC-motor controller for motors up to 3.0 A (peak) and 6.8 V DC?
- Do you need to drive a motor both forward and reverse?

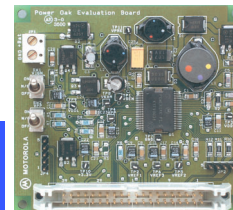

How to reach us:

USA/EUROPE/Locations Not Listed: Motorola Literature Distribution;
P.O. Box 5405, Denver, Colorado 80217
1-800-521-6274 or 480-768-2130

JAPAN: Motorola Japan Ltd.; SPS, Technical Information Center,
3-20-1, Minami-Azabu, Minato-ku, Tokyo 106-8573 Japan
81-3-3440-3569

ASIA/PACIFIC: Motorola Semiconductors H.K. Ltd.; Silicon Harbour Centre,
2 Dai King Street, Tai Po Industrial Estate, Tai Po, N.T., Hong Kong
852-26668334

HOME PAGE: <http://motorola.com/semiconductors>



MOTOROLA and the Stylized M Logo are registered in the U.S. Patent and Trademark Office. All other product or service names are the property of their respective owners. Motorola, Inc. is an Equal Opportunity/Affirmative Action Employer.

© Motorola, Inc. 2003

MPC17511FS/D
Rev. 1

**For More Information On This Product,
Go to: www.freescale.com**