

Stepper motor driver for automotive range

Features

- Able to drive both windings of bipolar stepper motor
- Output current up to 750 mA each winding
- Wide voltage range: 10 V to 46 V
- Half-step, full-step and microstepping mode
- Built-in protection diodes
- Internal PWM current control
- Low output saturation voltage
- Designed for unstabilized motor supply voltage
- Internal thermal shutdown

Description

The L6219DSA is a bipolar monolithic integrated circuits intended to control and drive both winding of a bipolar stepper motor or bidirectionally control two DC motors.

The L6219DSA with a few external components form a complete control and drive circuit for LS-TTL or microprocessor controlled stepper motor system. The power stage is a dual full bridge capable of sustaining 46 V and including four diodes for current recirculation.

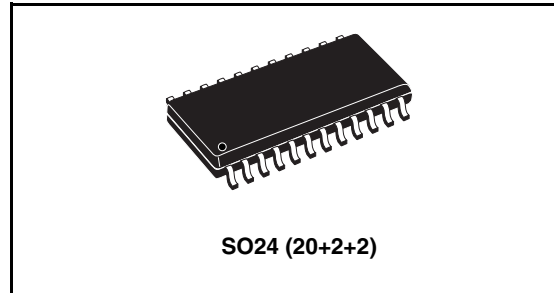

A cross conduction protection is provided to avoid simultaneous cross conduction during switching current direction.

An internal pulse-width-modulation (PWM) controls the output current to 750 mA with peak startup current up to 1 A.

Wide range of current control from 750 mA (each bridge) is permitted by means of two logic inputs and an external voltage reference. A phase input to each bridge determines the load current direction. A thermal protection circuitry disables the outputs if the chip temperature exceeds safe operating limits.

Table 1. Device summary

Order code	Package	Packing
E-L6219DSA	SO24	Tube
E-L6219DSATR	SO24	Tape & reel

Contents

1	Block diagram	5
2	Functional description	9
2.1	Input logic (I0 and I1)	9
2.2	Phase	9
2.3	Current sensor	9
2.4	Single-pulse generator	10
2.5	Output stage	10
2.6	VS, VSS, VRef	11
3	Application information	12
4	Package information	13
5	Revision history	14

List of tables

Table 1.	Device summary	1
Table 2.	Absolute maximum rating	5
Table 3.	Pin functions	6
Table 4.	Thermal data	7
Table 5.	Electrical characteristics	8
Table 6.	Current levels	9
Table 7.	Document revision history	14

List of figures

Figure 1.	Block diagram	5
Figure 2.	SO24 pins connection (top view)	6
Figure 3.	Timing diagram	7
Figure 4.	Principle operating sequence	10
Figure 5.	Typical application circuit	12
Figure 6.	SO24 mechanical data and package dimensions	13

1 Block diagram

Figure 1. Block diagram

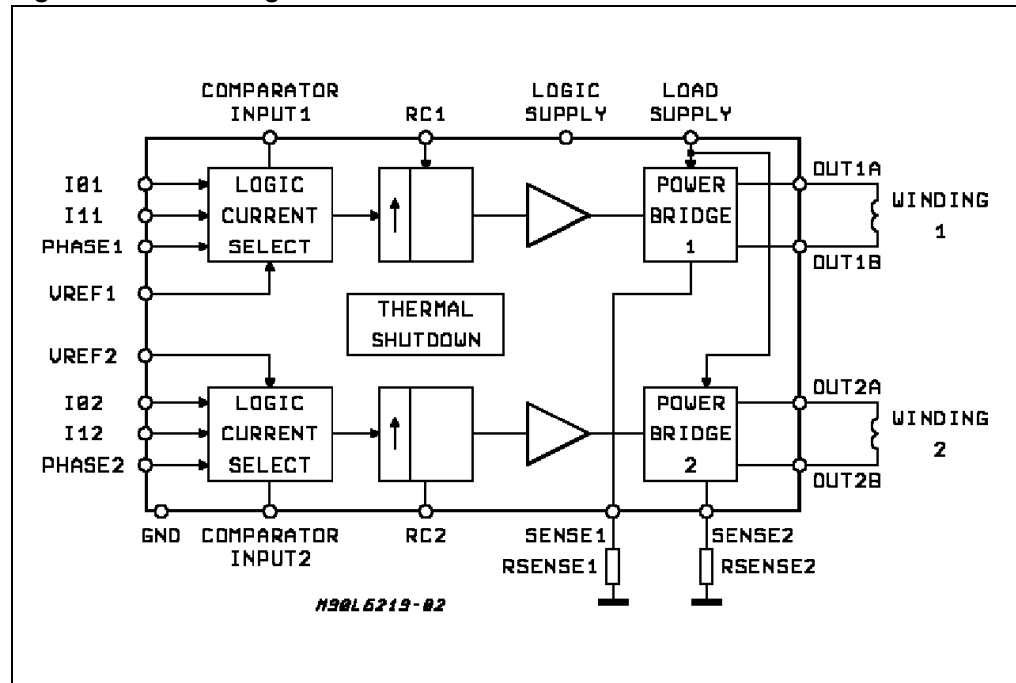

Table 2. Absolute maximum rating

Parameter	Description	Value	Unit
V_s	Supply voltage	50	V
I_o	Output current (peak)	± 1	A
I_o	Output current (continuous)	± 0.75	A
V_{ss}	Logic supply voltage	7	V
V_{in}	Logic input voltage range	-0.3 to +7	V
V_{sense}	Sense output voltage	1.5	V
T_j	Junction temperature	+150	°C
T_{op}	Operating temperature range	-40 to +125	°C
T_{stg}	Storage temperature range	-55 to +150	°C

Figure 2. SO24 pins connection (top view)

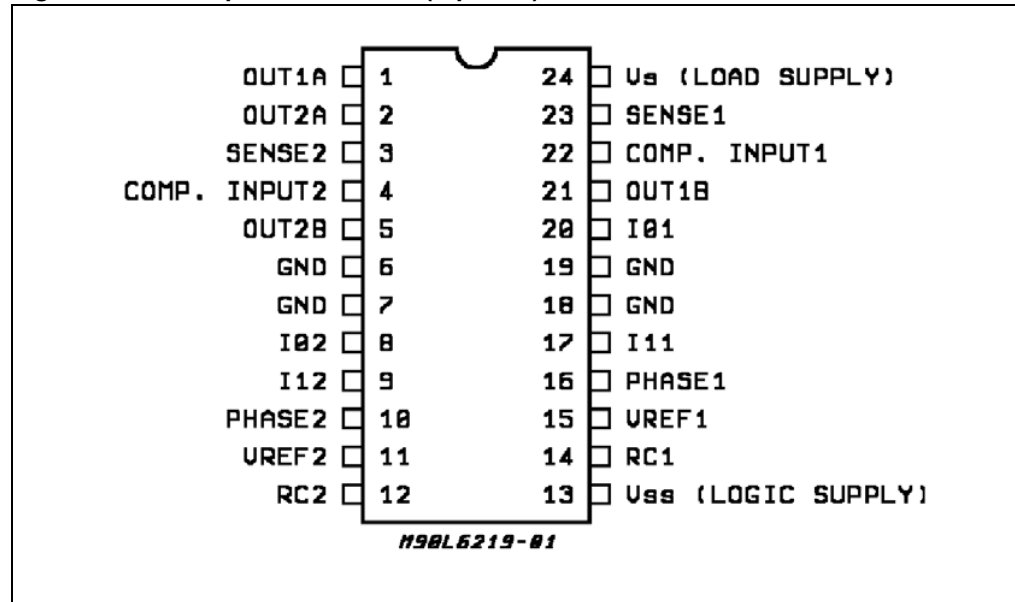

Table 3. Pin functions

Pin #	Name	Description
1, 21	Output of bridge 1	See pins 2, 5
3, 23	Sense resistor	Connection to lower emitters of output stage for insertion of current sense resistor
4, 22	Comparator input	Input connected to the comparators. The voltage across the sense resistor is feedback to this input through the low pass filter RC CC. The higher power transistors are disabled when the sense voltage exceeds the reference voltage of the selected comparator. When this occurs the current decays for a time set by $R_T C^T$ ($t_{off} = 1.1 R_T C_T$). See Figure 3 .
2, 5	Output of bridge 2	Output Connection. The output stage is a H bridge formed by four transistors and four diodes suitable for switching applications
6, 7, 18, 19	Ground	Ground connection, they also conducts heat from die to printed circuit copper
8, 20	Input 0	See input 1 (pins 9, 17)
9, 17	Input 1	These pins and pins 8, 20 (input 0) are logic inputs which select the outputs of the comparators to set the current level. Current also depends on the sensing resistor and reference voltage. See functional description

Table 3. Pin functions (continued)

Pin #	Name	Description
10, 16	Phase	This TTL-compatible logic inputs sets the direction of current flow through the load. A high level causes current to flow from output A (source) to output B (sink). A schmitt trigger on this input provides good noise immunity and a delay circuit prevents output stage short circuits during switching
11, 15	Reference voltage	A voltage applied to this pin sets the reference voltage of the comparators, this determining the output current (also thus depending on R_S and the two inputs input 0 and input 1)
12, 14	RC	A parallel RC network connected to this pin sets the off time of the higher power transistors. The pulse generator is a monostable triggered by the output of the comparators ($t_{off} = 1.1 R_T C_T$)
13	V_{SS} - Logic supply	Supply voltage input for logic circuitry
24	V_S - Load supply	Supply voltage input for the output stages

Note: ESD on GND, V_S , V_{SS} , OUT 1 A and OUT 2 A is guaranteed up to 1.5 KV (human body model, 1500 W, 100 pF).

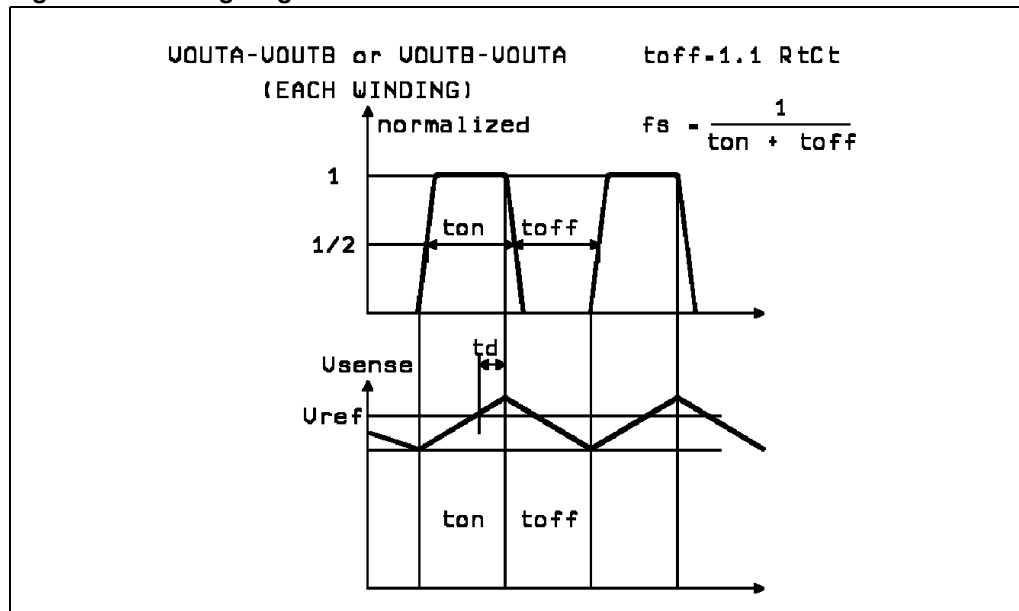
Figure 3. Timing diagram**Table 4. Thermal data**

Parameter	Description	PDIP	Unit
$R_{thj-case}$	Thermal resistance junction-case max.	18	$^{\circ}C/W$
$R_{thj-amb}$	Thermal resistance junction-ambient max.	75 ⁽¹⁾	$^{\circ}C/W$

1. With minimized copper area.

Table 5. Electrical characteristics

($T_J = 40\text{ }^\circ\text{C}$ to $125\text{ }^\circ\text{C}$, $V_S = 46\text{ V}$, $V_{SS} = 4.75\text{ V}$ to 5.25 V , $V_{REF} = 5\text{ V}$, unless otherwise specified) See [Figure 5](#)

Parameter	Description	Test condition	Min.	Typ.	Max.	Unit
Output drivers (OUT_A or OUT_B)						
V_S	Motor supply range		10	-	46	V
I_{CEX}	Output leakage current	$V_S = 52\text{ V } V_{OUT} = 50\text{ V}$ $V_S = 52\text{ V } V_{OUT} = 1\text{ V}$	-200	-	200	μA μA
$V_{CE(sat)}$	Output saturation voltage	Sink driver, $I_{OUT} = +500\text{ mA}$	-	-	0.75	V
		Sink driver, $I_{OUT} = +750\text{ mA}$	-	-	1.15	V
		Source driver, $I_{OUT} = -500\text{ mA}$	-	-	1.6	V
		Source driver, $I_{OUT} = -750\text{ mA}$	-	-	1.8	V
V_F	Clamp diode forward voltage	High stage $I_F = 750\text{ mA}$	-	-	1.7	V
		Low stage $I_F = 750\text{ mA}$	-	-	1.6	V
$I_{S(on)}$	Driver supply current	Both bridges ON, no load	-	-	17	mA
$I_{S(off)}$	Driver supply current	Both bridges OFF	-	-	12	mA
Control logic						
$V_{IN(H)}$	Input voltage	All inputs	2.4	-	-	V
$V_{IN(L)}$	Input voltage	All inputs	-	-	0.8	V
$I_{IN(H)}$	Input current	$V_{IN} = 2.4\text{ V}$	-	<1	20	μA
$I_{IN(L)}$	Input current	$V_{IN} = 0.84\text{ V}$	-	-3	-200	μA
V_{REF}	Reference voltage	Operating ⁽¹⁾	1.5	-	7.5	V
$I_{SS(ON)}$	Total logic supply current	$I_o = I_1 = 0.8\text{ V}$, no load	-	-	76	mA
$I_{SS(OFF)}$	Total logic supply current	$I_o = I_1 = 2.4\text{ V}$, no load	-	-	15	mA
Comparators						
V_{REF}/V_{sense}	Current limit threshold (at trip point)	$I_o = I_1 = 0.8\text{ V}$	9.5	10	10.5	-
		$I_o = 2.4\text{ V}$, $I_1 = 0.8\text{ V}$	13.5	15	16.5	-
		$I_o = 0.8\text{ V}$, $I_1 = 2.4\text{ V}$	25.5	30	34.5	-
t_{off}	Cutoff time	$R_1 = 56\text{ K}\Omega$ $C_1 = 820\text{ pF}$	-	50	-	μs
t_d	Turn off delay	Figure 3	-	1	-	μs
Protection						
T_J	Thermal shutdown temperature		-	170	-	$^\circ\text{C}$

1. To reduce the switching losses the base bias of the bridge's low side NPN transistor is proportional to the DAC output, then the output current driving capability is also proportional to the DAC output voltage, having as reference 750 mA with $V_{REF} = 5\text{ V}$ and DAC = 100%. For example using $V_{REF} = 2\text{ V}$ and DAC = 67% the output maximum current driving capability will become $750\text{ mA} \cdot (2\text{ V} \cdot 0.67) / (5\text{ V} \cdot 1) = 200\text{ mA}$.

2 Functional description

The circuit is intended to drive both windings of a bipolar stepper motor.

The peak current control is generated through switch mode regulation. There is a choice of three different current levels with the two logic inputs I_{01} - I_{11} for winding 1 and I_{02} - I_{12} for winding 2.

The current can also be switched off completely.

2.1 Input logic (I_0 and I_1)

The current level in the motor winding is selected with these inputs. (See [Figure 4](#)). If any of the logic inputs is left open, the circuit will treat it as a high level input.

Table 6. Current levels

I_0	I_1	Current level
H	H	No current
L	H	Low current $1/3 I_O$ max
H	L	Medium current $2/3 I_O$ max
L	L	Maximum current I_O max

2.2 Phase

This input determines the direction of current flow in the windings, depending on the motor connections. The signal is fed through a schmidt-trigger for noise immunity, and through a time delay in order to guarantee that no short-circuit occurs in the output stage during phase-shift. High level on the phase input causes the motor current flow from out A through the winding to out B.

2.3 Current sensor

This part contains a current sensing resistor (R_S), a low pass filter (R_C , C_C) and three comparators. Only one comparator is active at a time. It is activated by the input logic according to the current level chosen with signals I_0 and I_1 . The motor current flows through the sensing resistor R_S . When the current has increased so that the voltage across R_S becomes higher than the reference voltage on the other comparator input, the comparator goes high, which triggers the pulse generator.

The max peak current I_{max} can be defined by:

$$I_{max} = \frac{V_{ref}}{10R_s}$$

2.4 Single-pulse generator

The pulse generator is a monostable triggered on the positive going edge of the comparator output. The monostable output is high during the pulse time, t_{off} , which is determined by the time components R_t and C_t .

$$t_{off} = 1.1 \cdot R_t C_t$$

The single pulse switches off the power feed to the motor winding, causing the winding current to decrease during t_{off} . If a new trigger signal should occur during t_{off} , it is ignored.

2.5 Output stage

The output stage contains four darlington transistors (source drivers) four saturated transistors (sink drivers) and eight diodes, connected in two H bridge.

Figure 4. Principle operating sequence

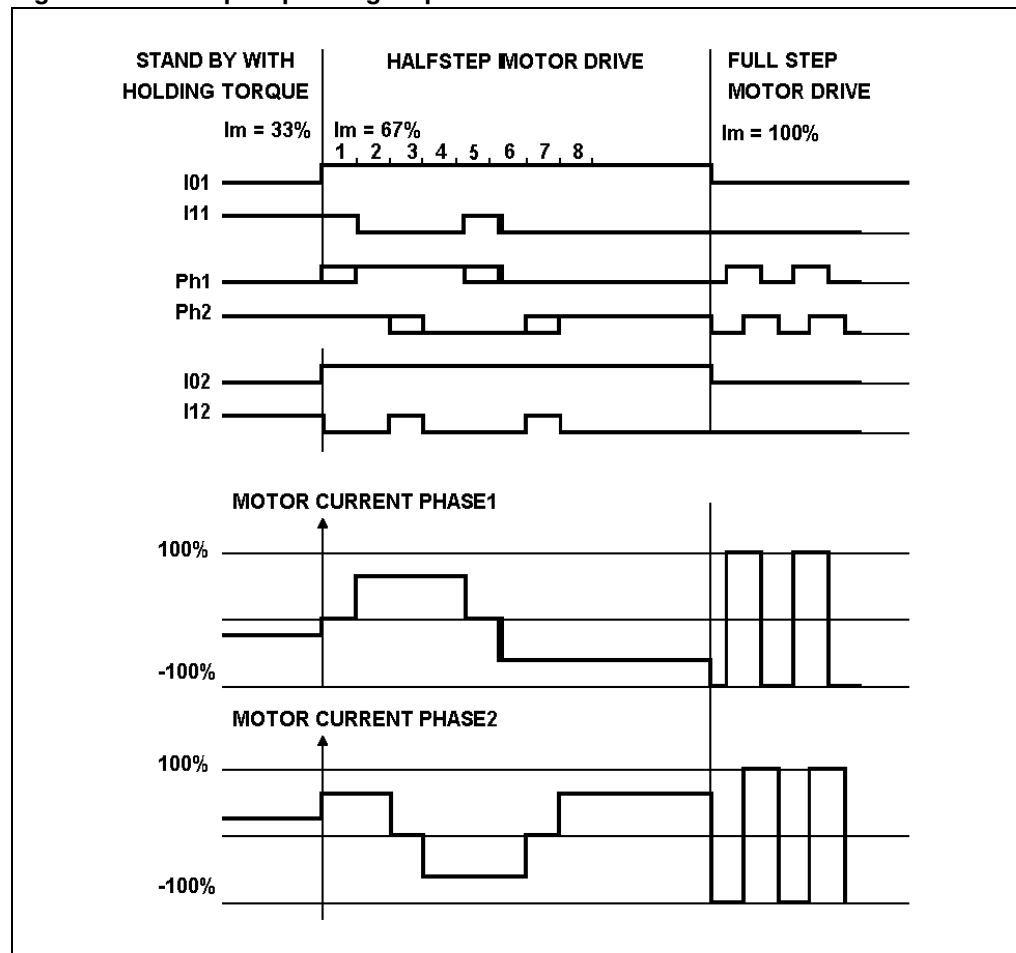

The source transistors are used to switch the power supplied to the motor winding, thus driving a constant current through the winding. It should be noted however, that is not permitted to short circuit the outputs.

Internal circuitry is added in order to increase the accuracy of the motor current particularly with low current levels.

2.6 V_S , V_{SS} , V_{Ref}

The circuit will stand any order of turn-on or turn-off the supply voltages V_S and V_{SS} . Normal dV/dt values are then assumed.

Preferably, V_{Ref} should be tracking V_{SS} during power-on and power-off if V_S is established.

3 Application information

Some stepper motors are not designed for continuous operation at maximum current. As the circuit drives a constant current through the motor, its temperature might increase exceedingly both at low and high speed operation. Also, some stepper motors have such high core losses that they are not suited for switch mode current regulation.

Unused inputs should be connected to proper voltage levels in order to get the highest noise immunity. As the circuit operates with switch mode current regulation, interference generation problems might arise in some applications. A good measure might then be to decouple the circuit with a 100 nF capacitor, located near the package between power line and ground. The ground lead between R_s and circuit GND should be kept as short as possible. A typical application circuit is shown in *Figure 5*. Note that C_t must be NPO type or similar else. To sense the winding current, paralleled metal film resistors are recommended (R_s).

Figure 5. Typical application circuit

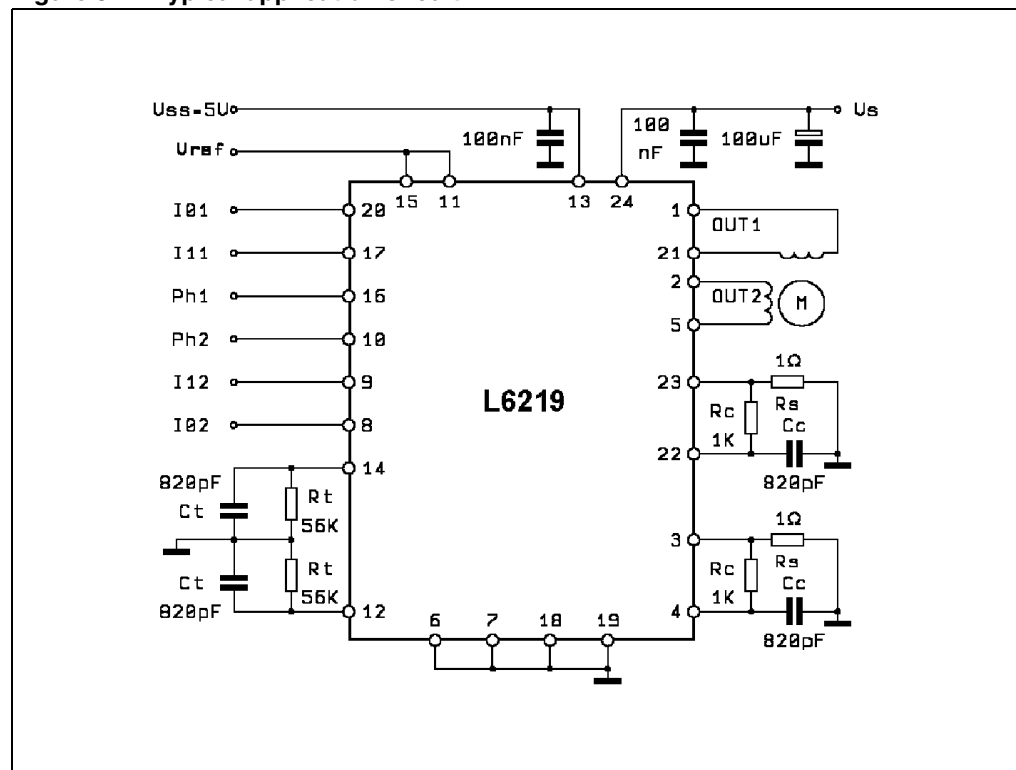

4 Package information

In order to meet environmental requirements, ST offers these devices in ECOPACK® packages. These packages have a Lead-free second level interconnect. The category of second Level Interconnect is marked on the package and on the inner box label, in compliance with JEDEC Standard JESD97. The maximum ratings related to soldering conditions are also marked on the inner box label.

ECOPACK is an ST trademark. ECOPACK specifications are available at: www.st.com.

Figure 6. SO24 mechanical data and package dimensions

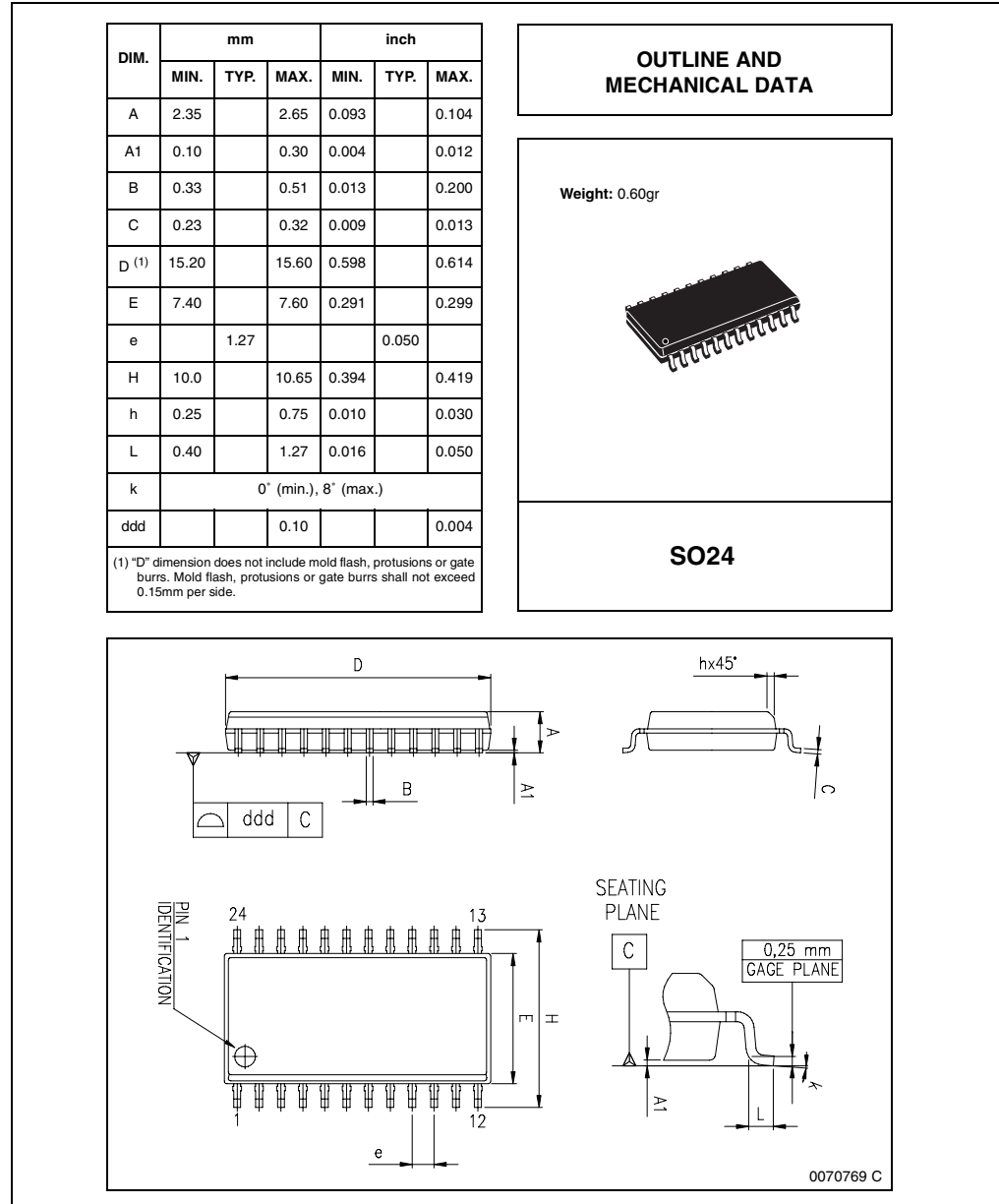

5 Revision history

Table 7. Document revision history

Date	Revision	Changes
12-Nov-1998	1	First Issue
29-Apr-2008	2	Document reformatted.
05-Sep-2008	3	Added note 1 in Table 5 on page 8 .

Please Read Carefully:

Information in this document is provided solely in connection with ST products. STMicroelectronics NV and its subsidiaries ("ST") reserve the right to make changes, corrections, modifications or improvements, to this document, and the products and services described herein at any time, without notice.

All ST products are sold pursuant to ST's terms and conditions of sale.

Purchasers are solely responsible for the choice, selection and use of the ST products and services described herein, and ST assumes no liability whatsoever relating to the choice, selection or use of the ST products and services described herein.

No license, express or implied, by estoppel or otherwise, to any intellectual property rights is granted under this document. If any part of this document refers to any third party products or services it shall not be deemed a license grant by ST for the use of such third party products or services, or any intellectual property contained therein or considered as a warranty covering the use in any manner whatsoever of such third party products or services or any intellectual property contained therein.

UNLESS OTHERWISE SET FORTH IN ST'S TERMS AND CONDITIONS OF SALE ST DISCLAIMS ANY EXPRESS OR IMPLIED WARRANTY WITH RESPECT TO THE USE AND/OR SALE OF ST PRODUCTS INCLUDING WITHOUT LIMITATION IMPLIED WARRANTIES OF MERCHANTABILITY, FITNESS FOR A PARTICULAR PURPOSE (AND THEIR EQUIVALENTS UNDER THE LAWS OF ANY JURISDICTION), OR INFRINGEMENT OF ANY PATENT, COPYRIGHT OR OTHER INTELLECTUAL PROPERTY RIGHT.

UNLESS EXPRESSLY APPROVED IN WRITING BY AN AUTHORIZED ST REPRESENTATIVE, ST PRODUCTS ARE NOT RECOMMENDED, AUTHORIZED OR WARRANTED FOR USE IN MILITARY, AIR CRAFT, SPACE, LIFE SAVING, OR LIFE SUSTAINING APPLICATIONS, NOR IN PRODUCTS OR SYSTEMS WHERE FAILURE OR MALFUNCTION MAY RESULT IN PERSONAL INJURY, DEATH, OR SEVERE PROPERTY OR ENVIRONMENTAL DAMAGE. ST PRODUCTS WHICH ARE NOT SPECIFIED AS "AUTOMOTIVE GRADE" MAY ONLY BE USED IN AUTOMOTIVE APPLICATIONS AT USER'S OWN RISK.

Resale of ST products with provisions different from the statements and/or technical features set forth in this document shall immediately void any warranty granted by ST for the ST product or service described herein and shall not create or extend in any manner whatsoever, any liability of ST.

ST and the ST logo are trademarks or registered trademarks of ST in various countries.

Information in this document supersedes and replaces all information previously supplied.

The ST logo is a registered trademark of STMicroelectronics. All other names are the property of their respective owners.

© 2008 STMicroelectronics - All rights reserved

STMicroelectronics group of companies

Australia - Belgium - Brazil - Canada - China - Czech Republic - Finland - France - Germany - Hong Kong - India - Israel - Italy - Japan - Malaysia - Malta - Morocco - Singapore - Spain - Sweden - Switzerland - United Kingdom - United States of America

www.st.com

