

MPC17511A

1.0 A 6.8 V H-Bridge Motor Driver IC

H-Bridge Motor Drivers

DESCRIPTION

The 17511A is a monolithic H-Bridge designed to be used in portable electronic applications to control small DC motors or bipolar step motors. End applications include head positioners (CDROM or disk drive), camera focus motors, and camera shutter solenoids.

The 17511A can operate efficiently with supply voltages as low as 2.0 V to as high as 6.8 V. Its low RDS(ON) H-Bridge output MOSFETs (0.46 Ω typical) can provide continuous motor drive currents of 1.0 A and handle peak currents up to 3.0 A. It is easily interfaced to low-cost MCUs via parallel 3.0 V- or 5.0 V- compatible logic. The device can be pulse width modulated (PWM-ed) at up to 200 kHz.

This device contains an integrated charge pump and level shifter (for gate drive voltages), integrated shoot-through current protection (cross-conduction suppression logic and timing), and undervoltage detection and shutdown circuitry.

The 17511A has four operating modes: Forward, Reverse, Brake, and Tri-States (High Impedance).

17511A SIMPLIFIED APPLICATION DIAGRAM

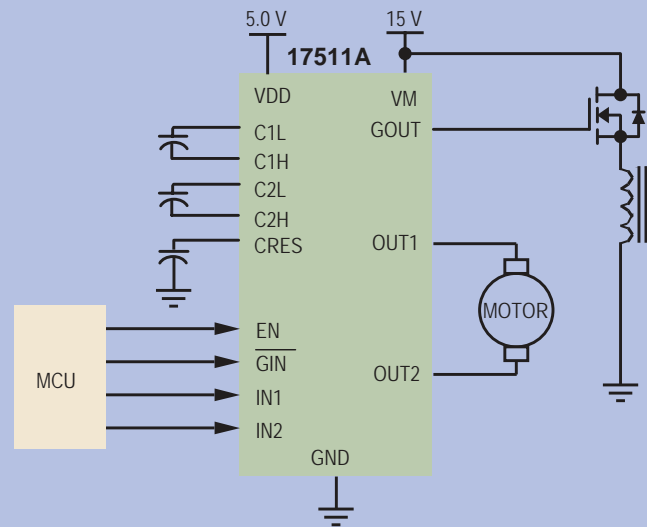

APPLICATIONS

- Portable Electronics
- Single Lens Camera
- Optical Disc Drive (MO, DVD, and CD)

PERFORMANCE

TYPICAL VALUES

Outputs	1 ch
Output Current	1.0 A (DC), 3.0 A (Peak)
Motor Operating Voltage	2.0 V – 6.8 V
Logic Operating Voltage	2.7 V – 5.7 V
Input PWM	200 kHz
Operating Temperature	-20°C ≤ T _A ≤ 65°C

FEATURES

- 2.0 V to 6.8 V continuous operation
- Output current 1.0 A (DC), 3.0 A (peak)
- MOSFETs < 600 mΩ R_{DS(ON)} @ 25°C guaranteed
- 3.0 V/5.0 V TTL-/CMOS-compatible inputs
- PWM frequencies up to 200 kHz
- Undervoltage shutdown
- Cross-conduction suppression
- Low power consumption
- Pb-free packaging designated by suffix codes EV and EP
- Devices available for comparison are in the Analog Product Selector Guide - SG1002, and Automotive Product Selector Guide - SG187.

QUESTIONS

- Are you working with portable electronic battery powered applications?
- Do you need to control a micro brush DC-motor in a 3.0 V or 5.0 V logic system?
- Are you designing a brush DC-motor controller for motors up 3.0 A (peak) and 6.8 V DC?
- Do you need to drive a motor both forward and reverse?

PROTECTION	DETECT	LIMITING	SHUT DOWN
Undervoltage	●		●

CUSTOMER BENEFITS

- Easy MCU interfacing and control of a single H-Bridge
- Undervoltage detection to prevent erratic operation
- High PWM rate for enhanced motor control
- Output protected H-Bridge operation to 6.8 V @ 1.0 A cont. PWM to 200 kHz
- Low profile package for portable designs
- Integral charge pump for a simpler system
- TSWITCH output for driving an external MOSFET
- Low quiescent current
- Reduced design time

ORDERING INFORMATION

Device	Temperature Range (T _A)	Package
**17511AEV/EL	-20°C to 65°C	16 VMFP
**17511AEP/R2		24 QFN
Data Sheet Order Number		MPC17511A

**Prefix Index:
PPC = Engineering Samples; MPC = Production

Contact Sales for Evaluation Kit Availability

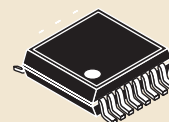

16 VMFP
0.65 mm Pitch
5.30 mm x 5.45 mm Body

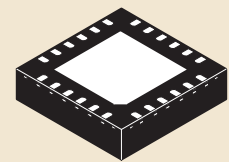

24 QFN
0.5 mm Pitch
4.0 mm x 4.0 mm x 1.0 mm Body