

TB6562ANG/AFG

Dual Full-Bridge Driver IC for Stepping Motors

The TB6562ANG/AFG is a 2-phase bipolar stepping motor driver that contains DMOS transistors in the output stage. The driver achieves high efficiency through the use of low ON-resistance DMOS transistors and PWM current control circuitry.

Features

- 2-phase / 1-2-phase / W 1-2-phase excitation
- PWM current control
- Power supply voltage: 40 V (max)
- Output current: 1.5 A (max)
- Low ON-resistance: 1.5 Ω (upper and lower transistors/typ.)
- Power-saving function
- Overcurrent protection: $I_{lim} = 2.5$ A (typ.)
- Thermal shutdown
- Package: TB6562ANG; SDIP24-P-300-1.78
TB6562ANG; SSOP30-P-375-1.00

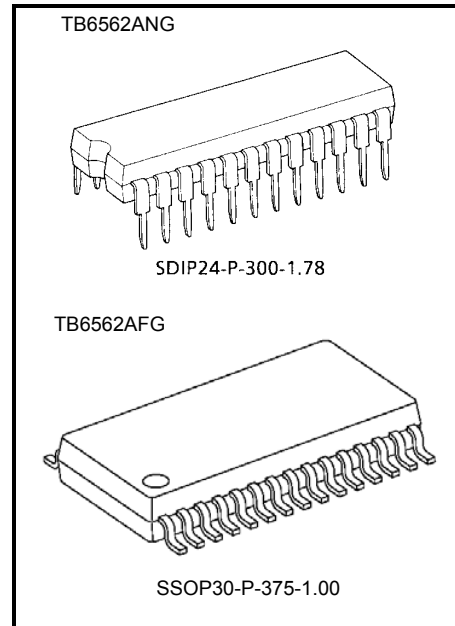

TB6562ANG/AFG is lead-free (Pb-free) product.

The following conditions apply to solderability:

***Solderability**

1. Use of Sn-37Pb solder bath
 - *solder bath temperature = 230°C
 - *dipping time = 5 seconds
 - *number of times = once
 - *use of R-type flux
2. Use of Sn-3.0Ag-0.5Cu solder bath
 - *solder bath temperature = 245°C
 - *dipping time = 5 seconds
 - *number of times = once
 - *use of R-type flux

Weight:

- SDIP24-P-300-1.78: 1.62 g (typ.)
- SSOP30-P-375-1.00: 0.63 g (typ.)

This product has a MOS structure and is sensitive to electrostatic discharge. When handling the product, ensure that the environment is protected against electrostatic discharge by using an earth strap, a conductive mat and an ionizer. Ensure also that the ambient temperature and relative humidity are maintained at reasonable levels.

Special care should be taken with the following pins, which are vulnerable to surge current.

Pins with low surge withstand capability:

TB6562ANG: pins 10, 15 TB6562AFG: pins 13, 18

Block Diagram

Some functional blocks, circuits, or constants may be omitted or simplified in the block diagram for explanatory purposes.

< TB6562ANG >

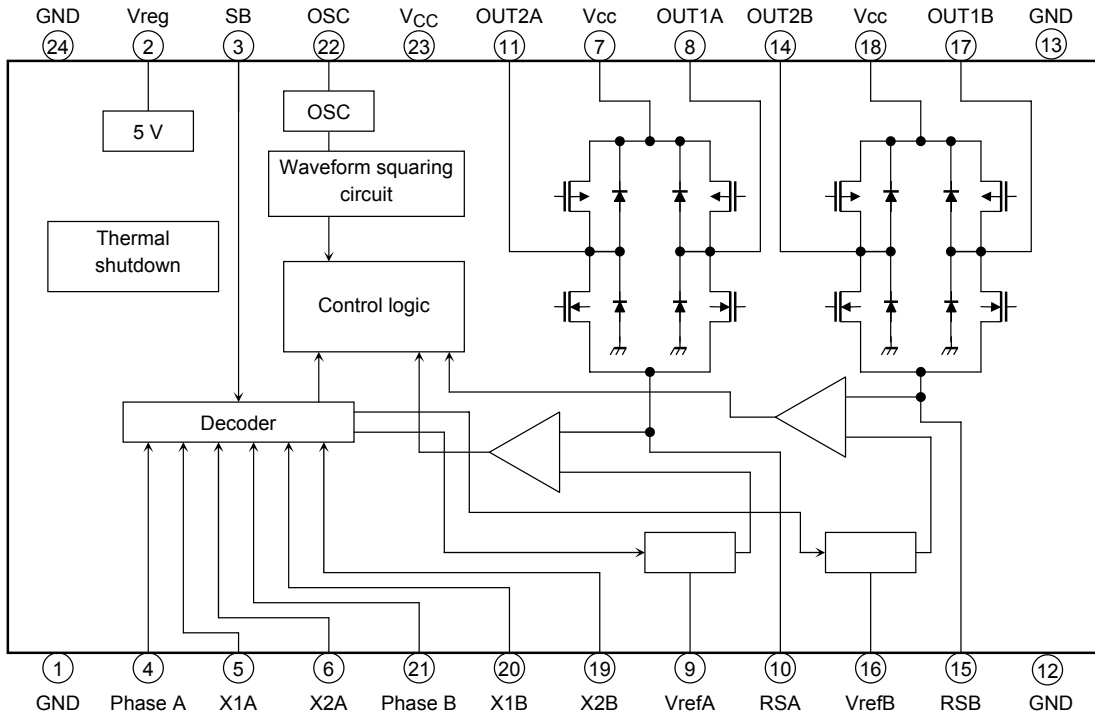

< TB6562AFG >

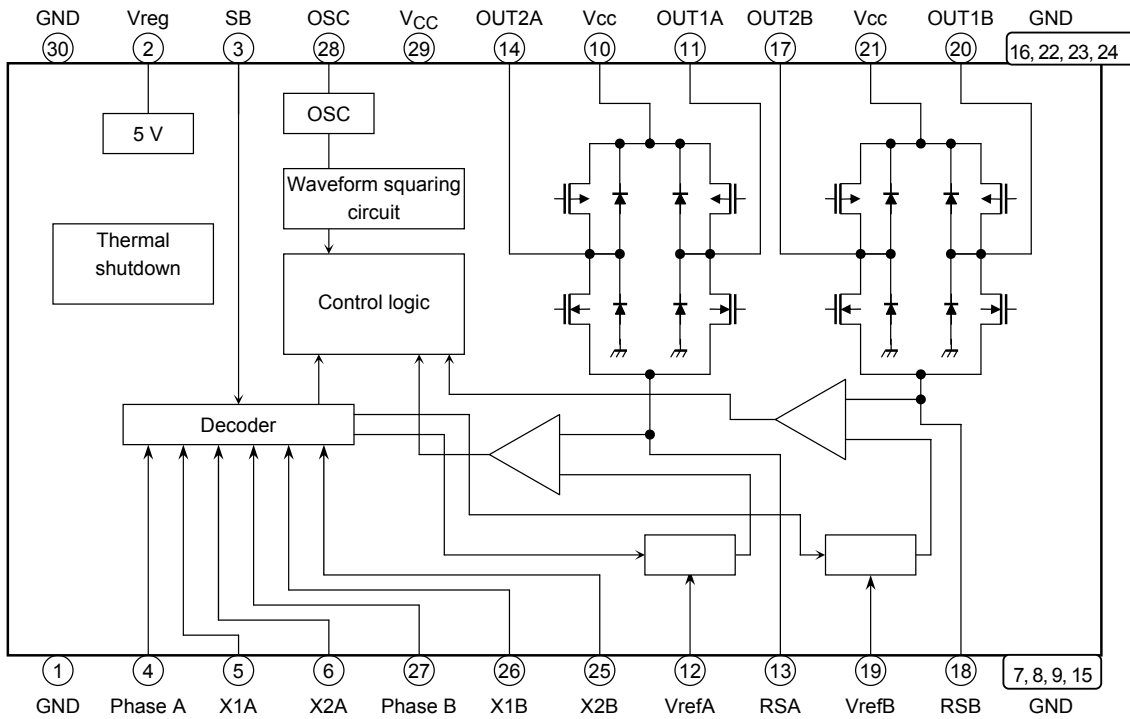

Pin Description

< TB6562ANG >

Pin No.	Symbol	Function Description	Remarks
1	GND	Ground pin	
2	Vreg	5 V output pin	Connect a capacitor between this pin and the GND pin.
3	SB	Standby pin	H: start, L: Standby, Built-in pull down resistance of 100k (typ.)
4	Phase A	Rotation direction control pin (Ch. A)	Apply a 0 V / 5 V signal, Built-in pull down resistance of 100k (typ.)
5	X1A	Input pin used to set output current level (Ch. A)	Apply a 0 V / 5 V signal, Built-in pull down resistance of 100k (typ.)
6	X2A	Input pin used to set output current level (Ch. A)	Apply a 0 V / 5 V signal, Built-in pull down resistance of 100k (typ.)
7	Vcc	Power supply voltage input pin	Vcc (opr) = 10 V to 34 V
8	OUT1A	Output pin 1 (Ch. A)	Connect to a motor coil pin.
9	VrefA	Input pin for external reference voltage (Ch. A)	
10	RSA	Output current detection resistor connection pin (Ch. A).	
11	OUT2A	Output pin 2 (Ch. A)	Connect to a motor coil pin.
12	GND	Ground pin	
13	GND	Ground pin	
14	OUT2B	Output pin 2 (Ch. B)	Connect to a motor coil pin.
15	RSB	Output current detection resistor connection pin (Ch. B)	
16	VrefB	Input pin for external reference voltage (Ch. B)	
17	OUT1B	Output pin 1 (Ch. B)	Connect to a motor coil pin.
18	Vcc	Power supply voltage input pin	Vcc (opr) = 10 V to 34 V
19	X2B	Input pin used to set output current level (Ch. B)	Apply a 0 V / 5 V signal, Built-in pull down resistance of 100k (typ.)
20	X1B	Input pin used to set output current level (Ch. B)	Apply a 0 V / 5 V signal, Built-in pull down resistance of 100k (typ.)
21	Phase B	Rotation direction control pin (Ch. B)	Apply a 0 V / 5 V signal, Built-in pull down resistance of 100k (typ.)
22	OSC	External capacitor pin for triangular-wave oscillation	
23	VCC	Power supply voltage input pin	VCC (opr) = 10 V to 34 V
24	GND	Ground pin	

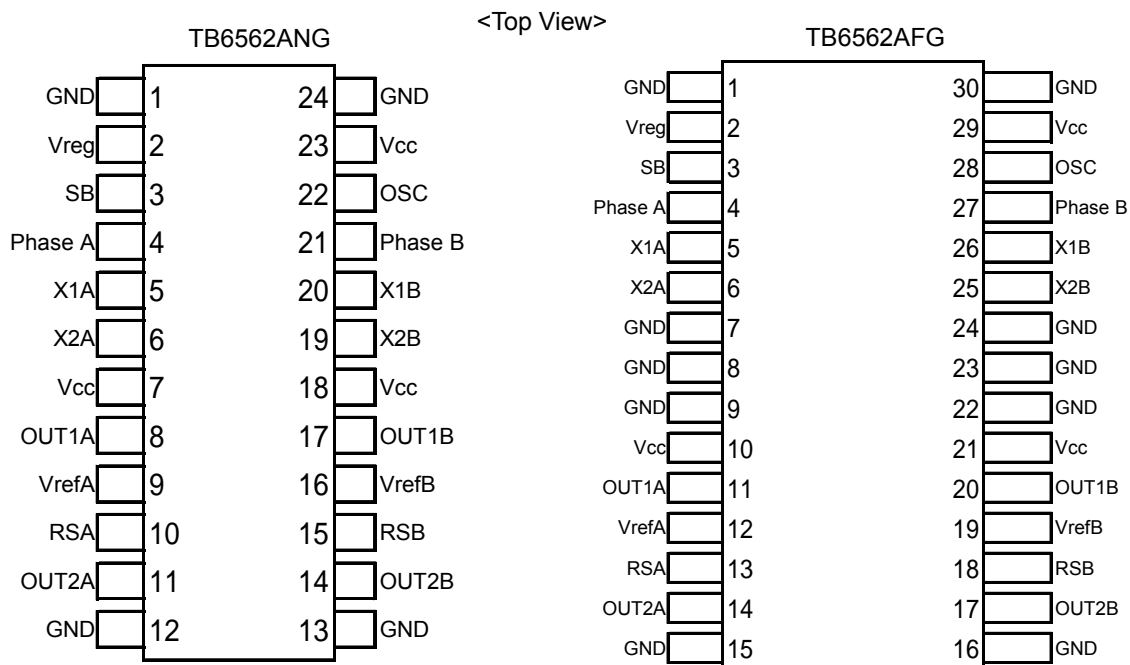

< TB6562AFG >

Pin No.	Symbol	Function Description	Remarks
1	GND	Ground pin	
2	Vreg	5 V output pin	Connect a capacitor between this pin and the GND pin.
3	SB	Standby pin	H: start, L: Standby, Built-in pull down resistance of 100k (typ.)
4	Phase A	Rotation direction control pin (Ch. A)	Apply a 0 V / 5 V signal, Built-in pull down resistance of 100k (typ.)
5	X1A	Input pin used to set output current level (Ch. A)	Apply a 0 V / 5 V signal, Built-in pull down resistance of 100k (typ.)
6	X2A	Input pin used to set output current level (Ch. A)	Apply a 0 V / 5 V signal, Built-in pull down resistance of 100k (typ.)
7	GND	Ground pin	
8	GND	Ground pin	
9	GND	Ground pin	
10	Vcc	Power supply voltage input pin	Vcc (opr) = 10 V to 34 V
11	OUT1A	Output pin 1 (Ch. A)	Connect to a motor coil pin.
12	VrefA	Reference voltage external set pin (Ch. A)	
13	RSA	Resistance connect pin for detecting output current (Ch. A)	
14	OUT2A	Output pin 2 (Ch. A)	Connect to a motor coil pin.
15	GND	Ground pin	
16	GND	Ground pin	
17	OUT2B	Output pin 2 (Ch. B)	Connect to a motor coil pin.
18	RSB	Output current detection resistor connection pin (Ch. B)	
19	VrefB	Input pin for external reference voltage (Ch. B)	
20	OUT1B	Output pin 1 (Ch. B)	Connect to a motor coil pin.
21	Vcc	Power supply voltage input pin	Vcc (opr) = 10 V to 34 V
22	GND	Ground pin	
23	GND	Ground pin	
24	GND	Ground pin	
25	X2B	Input pin used to set output current level (Ch. B)	Apply a 0 V / 5 V signal, Built-in pull down resistance of 100k (typ.)
26	X1B	Input pin used to set output current level (Ch. B)	Apply a 0 V / 5 V signal, Built-in pull down resistance of 100k (typ.)
27	Phase B	Rotation direction control pin (Ch. B)	Apply a 0 V / 5 V signal, Built-in pull down resistance of 100k (typ.)
28	OSC	External capacitor pin for triangular-wave oscillation	
29	V _{CC}	Power supply voltage input pin	V _{CC} (opr) = 10 V to 34 V
30	GND	Ground pin	

Absolute Maximum Ratings (Ta = 25°C)

Characteristic	Symbol	Rating	Unit
Power supply voltage	V _{CC}	40	V
Output voltage	V _o	40	V
Output current	I _O (Peak)	1.5 (Note 1)	A
Input voltage	V _{in}	-0.2 to 5.5	V
Power dissipation	P _D	2.5 (Note 2)	W
Operating temperature	T _{opr}	-20 to 85	°C
Storage temperature	T _{stg}	-55 to 150	°C
Junction temperature	T _{jmax}	150	°C

Note 1: Output current may be controlled by excitation mode, ambient temperature, or heatsink.
When designing a circuit, ensure that the maximum junction temperature, T_{JMAX} = 150°C, is not exceeded when the IC is used.

Avoid using the IC in abnormal conditions that would cause the T_j to exceed 150°C, even though the heat protection circuit of the IC will continue to operate in such conditions.

Note 2: When mounted on a board (50 mm × 50 mm × 1.6 mm, Cu area: 50%)

The absolute maximum ratings of a semiconductor device are a set of specified parameter values that must not be exceeded during operation, even for an instant.

If any of these ratings are exceeded during operation, the electrical characteristics of the device may be irreparably altered, in which case the reliability and lifetime of the device can no longer be guaranteed.

Moreover, any exceeding of the ratings during operation may cause breakdown, damage and/or degradation in other equipment. Applications using the device should be designed so that no maximum rating will ever be exceeded under any operating condition.

Before using, creating and/or producing designs, refer to and comply with the precautions and conditions set forth in this document.

Operating Range (Ta = -20 to 85°C)

Characteristic	Symbol	Rating	Unit
Power supply voltage	V _{CC}	10 to 34	V
Input voltage	V _{in}	0 to 5	V
Vref voltage	V _{ref}	0.5 to 7.0	V
PWM frequency	f _{pwm}	15 to 80	kHz
Triangular-wave oscillation frequency	f _{osc}	45 to 400	kHz

Electrical Characteristics (V_{CC} = 24 V, Ta = 25°C)

Characteristic		Symbol	Test Circuit	Test Condition	Min	Typ.	Max	Unit
Supply current		I _{CC1}	—	XT1A = XT2A = H, XT1B = XT2B = H Output = Open	—	6.5	10	mA
		I _{CC2}		XT1A = XT2A = L, XT1B = XT2B = L Output = Open	—	7.0	12	
		I _{CC3}		Standby mode	—	2.0	4.0	
Control circuit (Note 1)	Input voltage	V _{INH}	—	—	2	—	5.5	V
		V _{INL}		—	-0.2	—	0.8	
	Input hysteresis voltage	V _{IN (HYS)}	—	(Target spec.)	—	0.4	—	
	Input current	I _{INH}	—	V _{IN} = 5 V	30	50	75	μA
I _{INL}		V _{IN} = 0 V		—	—	5		
Standby circuit	Input voltage	V _{INSH}	—	—	2.3	—	5.5	V
		V _{INSL}		—	-0.2	—	0.8	
	Input hysteresis voltage	V _{IN (HYS)}	—	(Target spec.)	—	0.4	—	
	Input current	I _{INSH}	—	V _{IN} = 5 V	30	50	75	μA
I _{INSL}		V _{IN} = 0 V		—	—	5		
Output ON-resistance		R _{on (U + L)}	—	I _O = 0.2 A	—	1.5	2.0	Ω
				I _O = 1.5 A	—	1.5	2.0	
Output leakage current		I _{L (U)}	—	V _{CC} = 40 V	—	—	10	μA
		I _{L (L)}		V _{CC} = 40 V	—	—	10	
Diode forward voltage		V _{F (U)}	—	I _O = 1.5 A	—	1.3	2.0	V
		V _{F (L)}		I _O = 1.5 A	—	1.3	2.0	
Internal reference voltage		V _{reg}	—	1 mA	4.75	5	5.25	V
V _{ref} circuit	Input current	I _{ref}	—	V _{ref} = 0.5 V	—	5	10	μA
	Current limit voltage	V _{ref (1/10)}	—	X1 = X2 = L V _{ref} = 5 V	0.45	0.5	0.55	V
		V _{ref (1/15)}	—	X1 = L, X2 = H V _{ref} = 5 V	0.28	0.33	0.38	
		V _{ref (1/30)}	—	X1 = H, X2 = L V _{ref} = 5 V	0.12	0.17	0.22	
Triangular-wave oscillation frequency		f _{osc}	—	C = 4700 pF	88	110	132	kHz
Thermal shutdown circuit operating temperature		TSD	—	(Target spec.)	—	160	—	°C

Note 1: Phase, X1 and X2 pins

Truth Tables

< 2-phase excitation > (*) I_o: OUT1 OUT2; + current OUT2 OUT1; - current

Phase A				Phase B			
Input			Output	Input			Output
Phase A	X1A	X2A	I _o (A)	Phase B	X1B	X2B	I _o (B)
H	L	L	100%	H	L	L	100%
L	L	L	-100%	H	L	L	100%
L	L	L	-100%	L	L	L	-100%
H	L	L	100%	L	L	L	-100%

< 1-2-phase excitation >

Phase A				Phase B			
Input			Output	Input			Output
Phase A	X1A	X2A	I _o (A)	Phase B	X1B	X2B	I _o (B)
H	L	L	100%	H	L	L	100%
X	H	H	0%	H	L	L	100%
L	L	L	-100%	H	L	L	100%
L	L	L	-100%	X	H	H	0%
L	L	L	-100%	L	L	L	-100%
X	H	H	0%	L	L	L	-100%
H	L	L	100%	L	L	L	-100%
H	L	L	100%	X	H	H	0%

< W 1-2-phase excitation >

Phase A				Phase B			
Input			Output	Input			Output
Phase A	X1A	X2A	I _o (A)	Phase B	X1B	X2B	I _o (B)
X	H	H	0%	L	L	L	-100%
H	H	L	33.3%	L	L	L	-100%
H	L	H	66.7%	L	L	H	-66.7%
H	L	L	100%	L	H	L	-33.3%
H	L	L	100%	X	H	H	0%
H	L	L	100%	H	H	L	33.3%
H	H	L	33.3%	H	L	H	66.7%
H	L	H	66.7%	H	L	L	100%
X	H	H	0%	H	L	L	100%
L	H	L	-33.3%	H	L	L	100%
L	L	H	-66.7%	H	L	H	66.7%
L	L	L	-100%	H	H	L	33.3%
L	L	L	-100%	X	H	H	0%
L	L	L	-100%	L	H	L	-33.3%
L	L	H	-66.7%	L	L	H	-66.7%
L	H	L	-33.3%	L	L	L	-100%

Timing Charts

Timing charts may be simplified for explanatory purposes.

< 2-phase excitation >

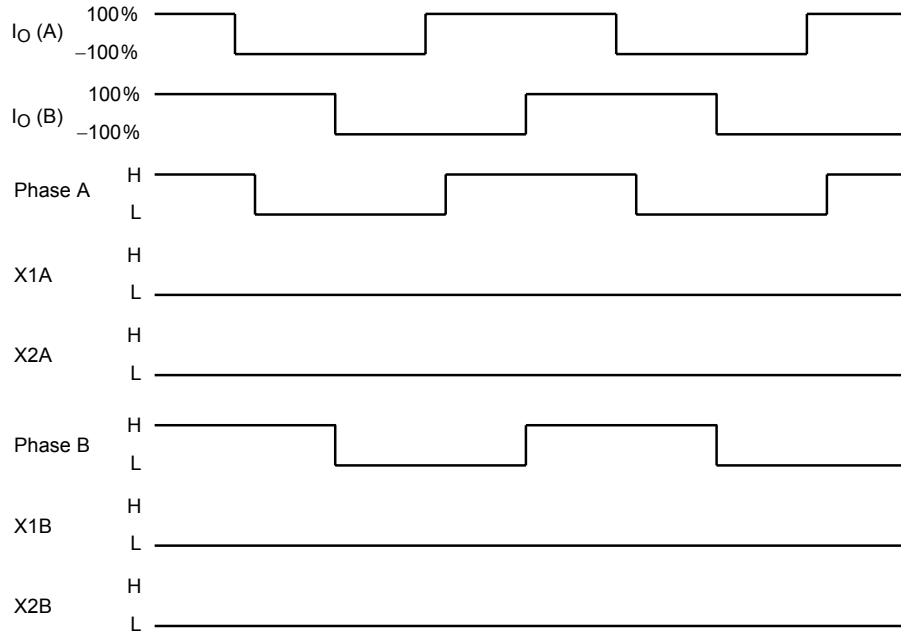

(*) I_O: OUT1 OUT2; + current OUT2 OUT1; - current

< 1-2-phase excitation >

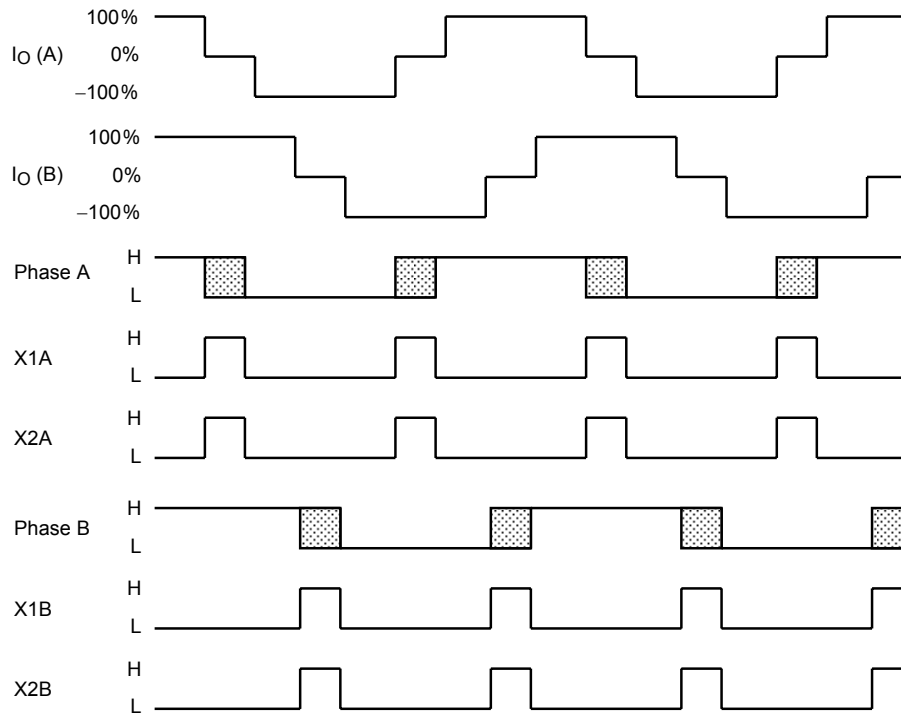

(*) I_O: OUT1 OUT2; + current OUT2 OUT1; - current

< W 1-2-phase excitation >

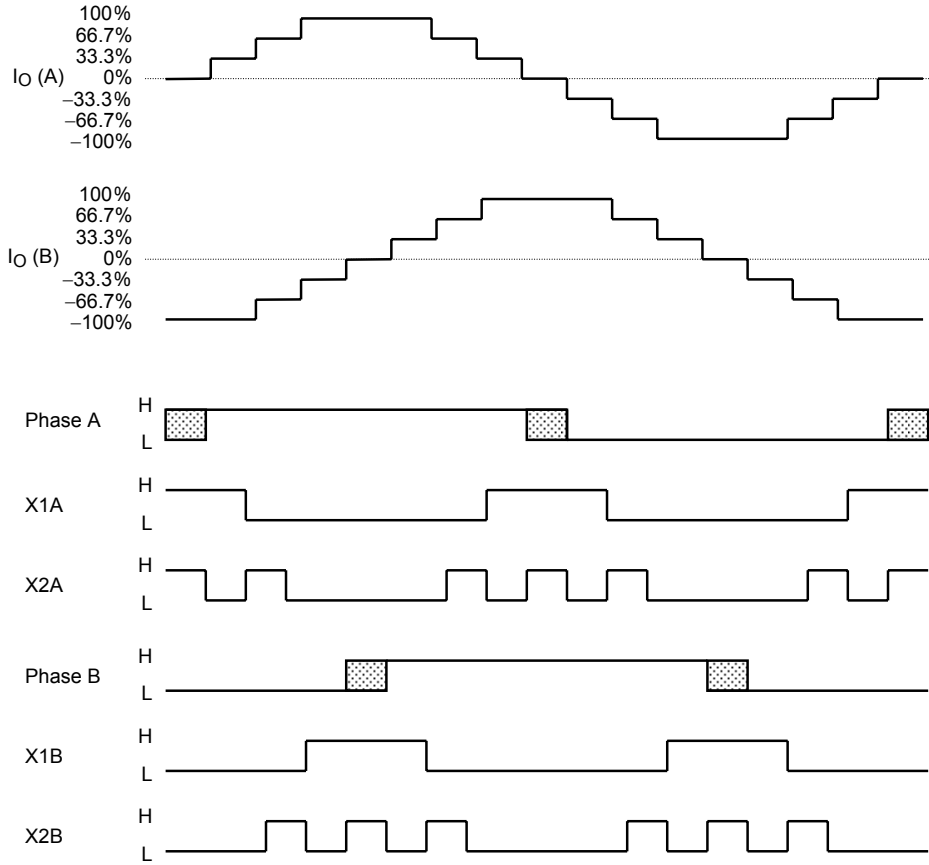

(*) Io: OUT1 OUT2; + current OUT2 OUT1; - current

PWM Current Control

The IC enters CW (CCW) mode and short brake mode alternately during PWM current control.

To prevent shoot-through current caused by simultaneous conduction of upper and lower transistors in the output stage, a dead time is internally generated for 300 ns (target spec) when the upper and lower transistors are being switched.

Therefore synchronous rectification for high efficiency in PWM current control can be achieved without an off-time generated via an external input.

Even for toggling between CW and CCW modes, and CW (CCW) and short brake modes, no off-time is required due to the internally generated dead time.

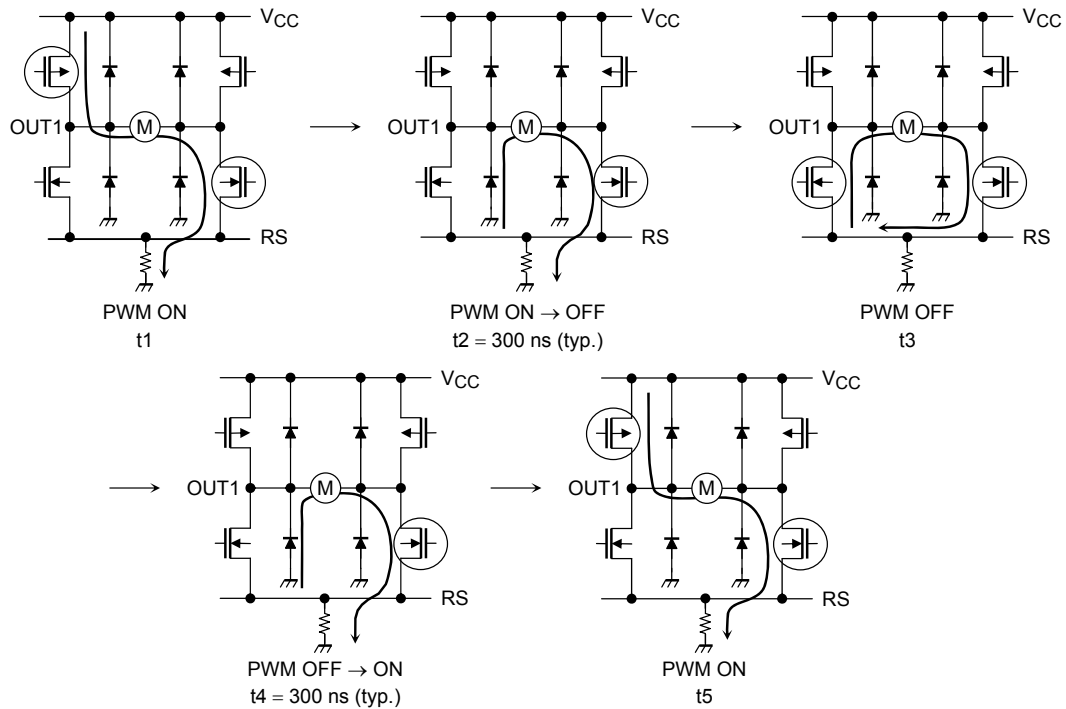

Constant current regulation

When V_{RS} reaches the reference voltage (V_{ref}), the IC enters discharge mode. After four clock signals are generated from the oscillator, the IC moves from discharge mode to charge mode.

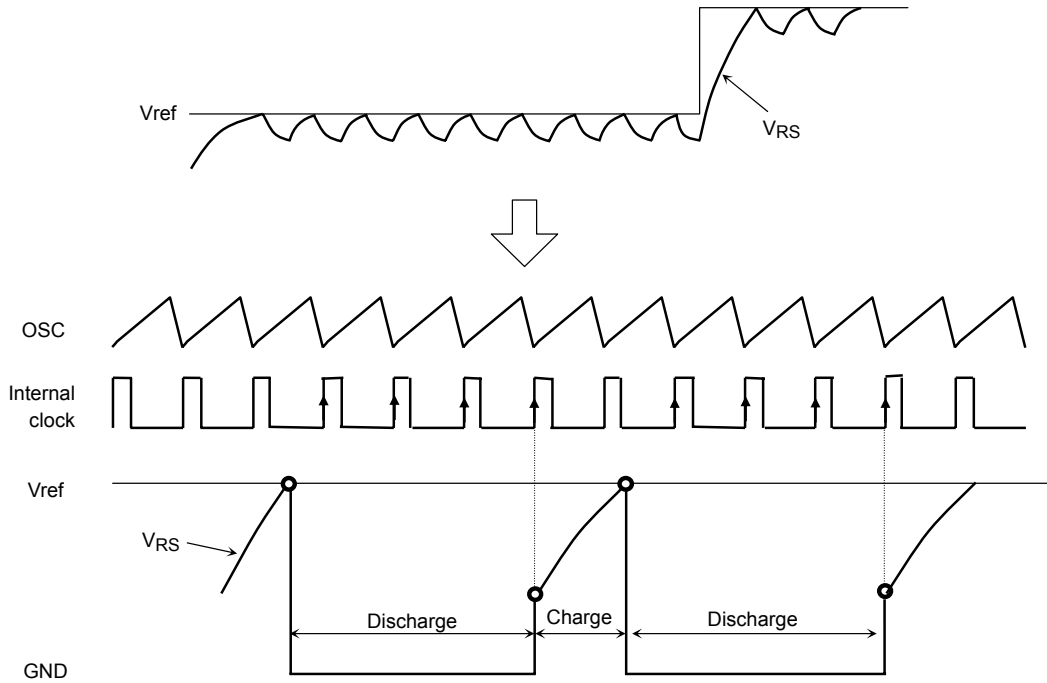

Transition from charge mode to discharge mode

If $V_{RS} > V_{ref}$ after four clock signals in charge mode, the IC again enters discharge mode. After a further four clock signals in discharge mode, V_{RS} is compared with V_{ref} . If $V_{RS} < V_{ref}$, the IC operates in charge mode until V_{RS} reaches V_{ref} .

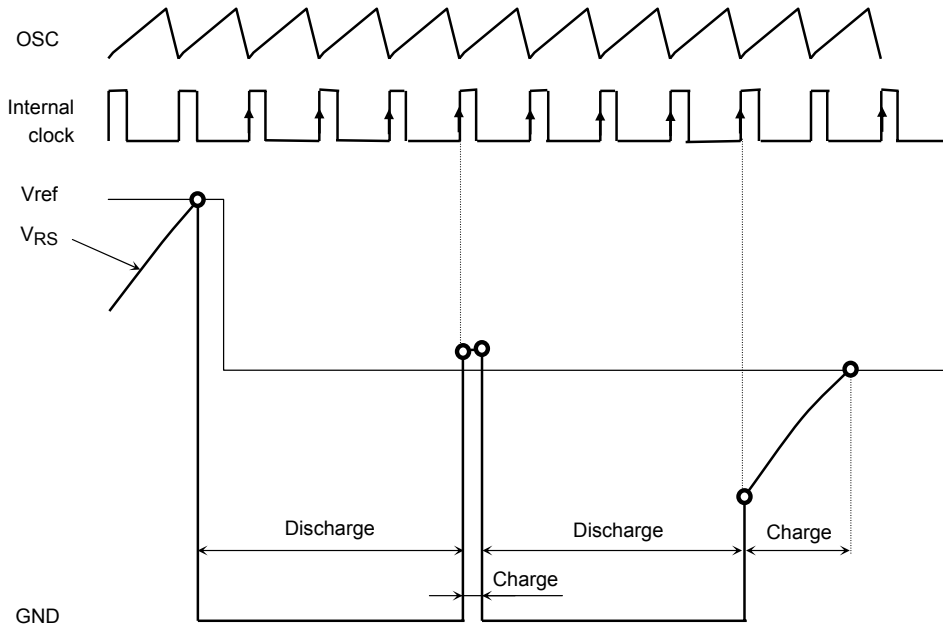

Transition from discharge mode to charge mode

Even when the reference voltage has risen, discharge mode lasts for four clock signals and is then toggled to charge mode.

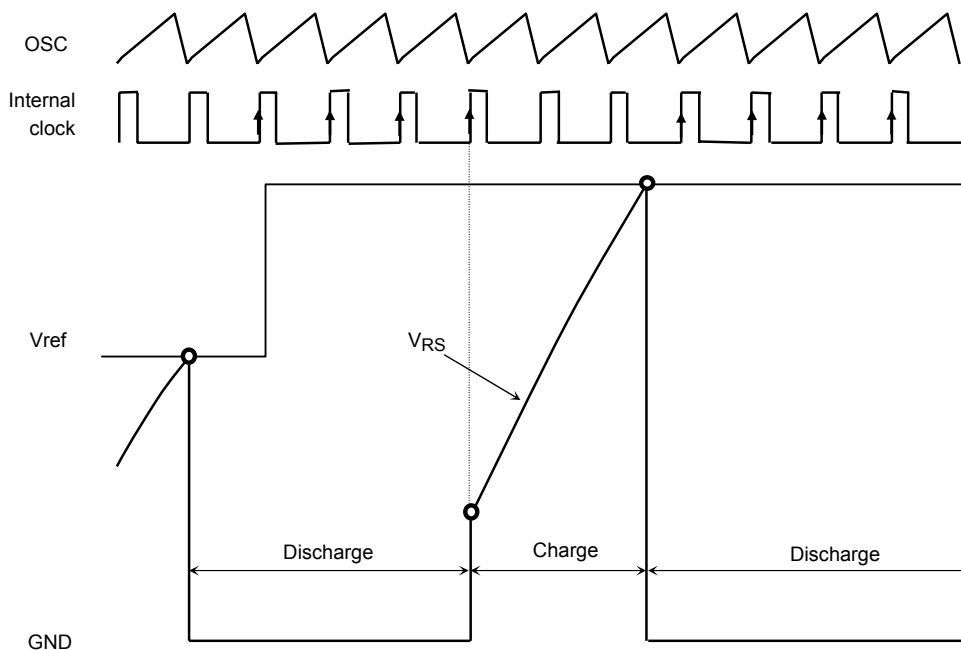

Timing charts may be simplified for explanatory purposes.

Internal oscillation frequency (fosc)

The internal oscillation frequency is approximated by the formula below:

$$f_{osc} = 1 / (0.523 \times (C_{osc} \times 3700 + C_{osc} \times 600)).$$

Reference Voltage Generator

The current value at 100% is determined by applying voltage at the Vref pin.

The value can be calculated as follows: $I_O (100\%) = V_{ref} \times 1/10 \times 1/RS[A]$ ($X1 = X2 = L$)

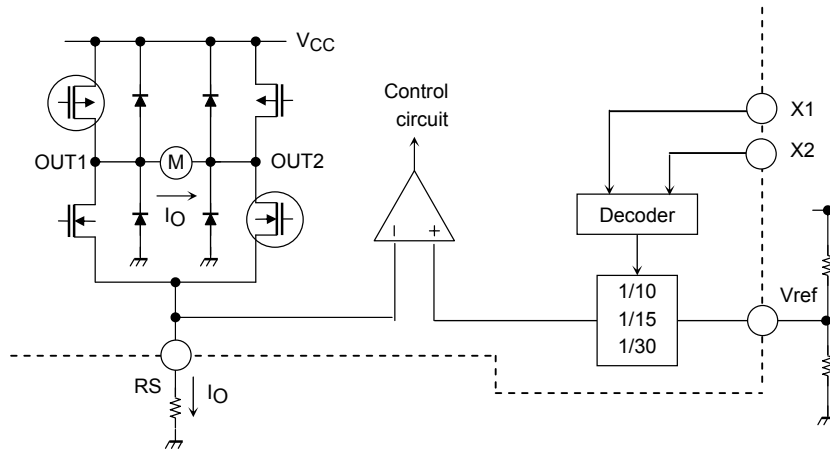

Thermal Shutdown Circuit (TSD)

The IC incorporates a thermal shutdown circuit. When the junction temperature (T_j) reaches 160°C (typ.), the output transistors are turned off.

After 50 μs (typ.), the output transistors are turned on automatically.

The IC has 40°C temperature hysteresis.

TSD = 160°C (target spec)

$\Delta TSD = 40^\circ C$ (target spec)

Overcurrent Protection Circuit (ISD)

The IC incorporates an overcurrent protection circuit to detect voltage flowing through the output transistors. The overcurrent threshold is 2.5 A (typ.).

Currents flowing through the eight output transistors are monitored individually. If overcurrent is detected in at least one of the transistors, all transistors are turned off.

The IC incorporates a timer to count the 50 μs (typ.) for which the transistors are off. After the 50 μs , the transistors are turned on automatically. If an overcurrent occurs again, the same operation is repeated. To prevent false detection due to glitches, the circuit turns off the transistors only when current exceeding the overcurrent threshold flows for 10 μs or longer.

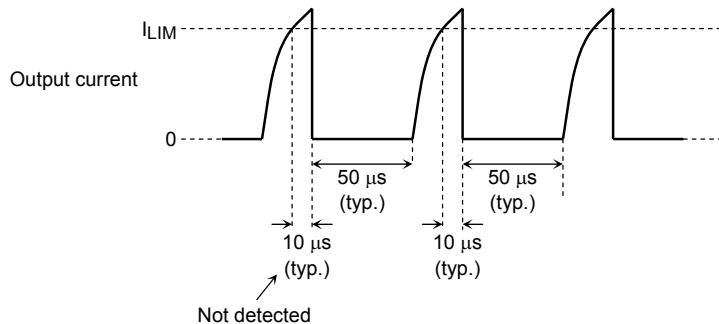

The target specification for the overcurrent limiter value (overcurrent threshold) is 2.5 A (typ.), and varies in a range from approximately 1.5 A to 3.5 A.

These protection functions are intended only as a temporary means of preventing output short circuits or other abnormal conditions and are not guaranteed to prevent damage to the IC.

If the guaranteed operating ranges of this product are exceeded, these protection features may not operate and some output short circuits may result in the IC being damaged.

The overcurrent protection feature is intended to protect the IC from temporary short circuits only.

Short circuits persisting over long periods may cause excessive stress and damage the IC. Systems should be configured so that any overcurrent condition will be eliminated as soon as possible.

Application Circuit

The application circuit below is for reference only and requires thorough evaluation at the mass production design stage. In furnishing this example of an application circuit, Toshiba does not grant the use of any industrial property rights.

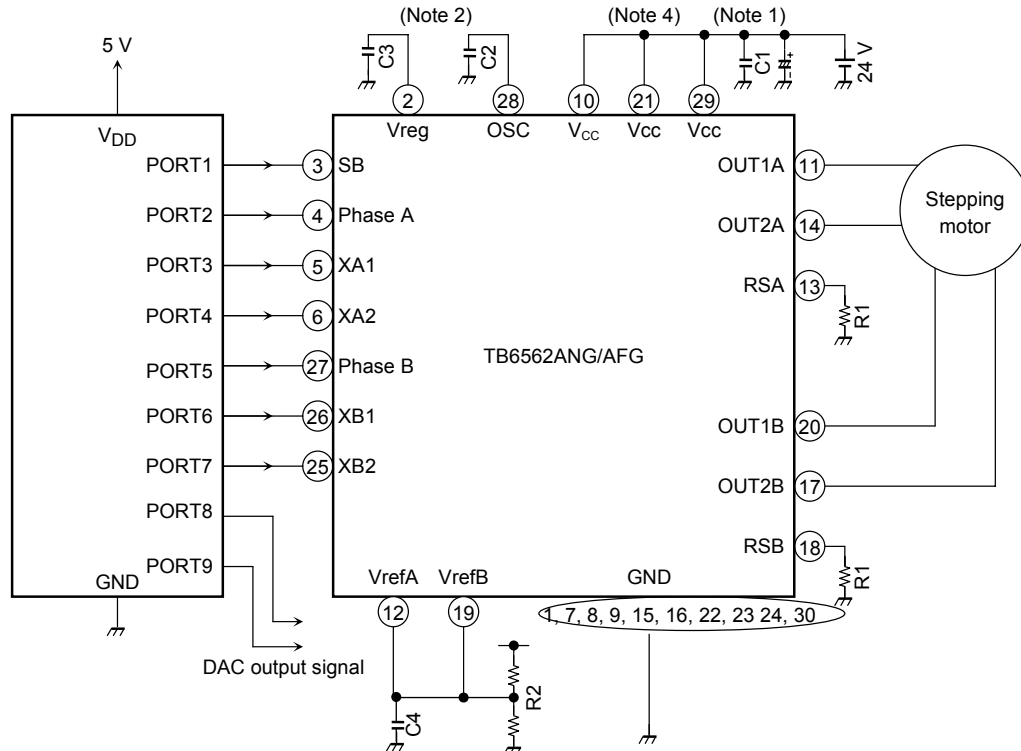

Note 1: A power supply capacitor should be connected between V_{CC} and RSA (RSB), and as close as possible to the IC.

Note 2: C2 and C3 should be connected as close as possible to S-GND.

Note 3: In powering on, set the IC as follows:
 SB = Low (standby mode)
 or
 XA1 = XA2 = XB1 = XB2 = High (current value = 0%)

Note 4: When the Vref is being changed, a DAC output can be connected directly to the Vref pin.

Note 5: The V_{CC} pins (pin 10, pin 21, pin 29) should be shorted externally.

Note 6: Connect the capacitor C4 to the Vref to reduce the switching noise.

Package Dimensions

SDIP24-P-300-1.78

Unit : mm

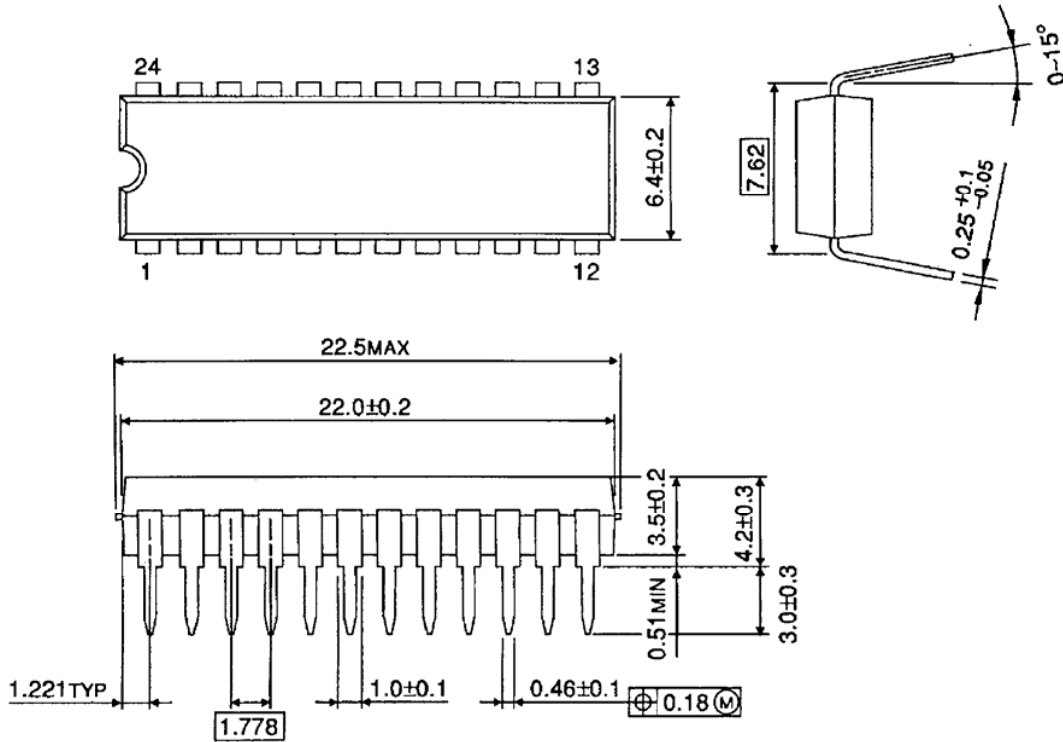

Weight: 1.62 g (typ.)

SSOP30-P-375-1.00

Unit : mm

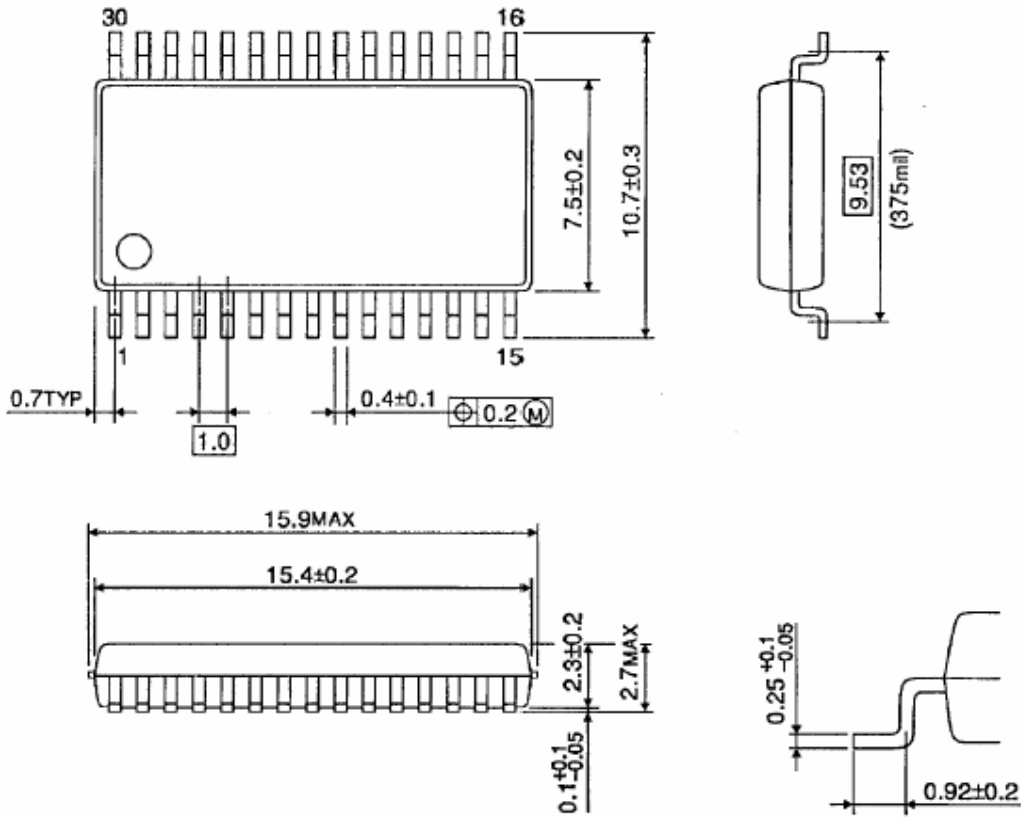

Weight: 0.63 g (typ.)

Notes on Contents

1. Block Diagrams

Some of the functional blocks, circuits, or constants in the block diagram may be omitted or simplified for explanatory purposes.

2. Equivalent Circuits

The equivalent circuit diagrams may be simplified or some parts of them may be omitted for explanatory purposes.

3. Timing Charts

Timing charts may be simplified for explanatory purposes.

4. Application Circuits

The application circuits shown in this document are provided for reference purposes only. Thorough evaluation is required, especially at the mass production design stage.

Toshiba does not grant any license to any industrial property rights by providing these examples of application circuits.

5. Test Circuits

Components in the test circuits are used only to obtain and confirm the device characteristics. These components and circuits are not guaranteed to prevent malfunction or failure from occurring in the application equipment.

IC Usage Considerations

Notes on handling of ICs

- [1] The absolute maximum ratings of a semiconductor device are a set of ratings that must not be exceeded, even for a moment. Do not exceed any of these ratings.
Exceeding the rating(s) may cause the device breakdown, damage or deterioration, and may result in injury by explosion or combustion.
- [2] Use an appropriate power supply fuse to ensure that a large current does not continuously flow in case of over current and/or IC failure. The IC will fully break down when used under conditions that exceed its absolute maximum ratings, when the wiring is routed improperly or when an abnormal pulse noise occurs from the wiring or load, causing a large current to continuously flow and the breakdown can lead to smoke or ignition. To minimize the effects of the flow of a large current in case of breakdown, appropriate settings, such as fuse capacity, fusing time and insertion circuit location, are required.
- [3] If your design includes an inductive load such as a motor coil, incorporate a protection circuit into the design to prevent device malfunction or breakdown caused by the current resulting from the inrush current at power ON or the negative current resulting from the back electromotive force at power OFF. IC breakdown may cause injury, smoke or ignition.
Use a stable power supply with ICs with built-in protection functions. If the power supply is unstable, the protection function may not operate, causing IC breakdown. IC breakdown may cause injury, smoke or ignition.
- [4] Do not insert devices in the wrong orientation or incorrectly.
Make sure that the positive and negative terminals of power supplies are connected properly. Otherwise, the current or power consumption may exceed the absolute maximum rating, and exceeding the rating(s) may cause the device breakdown, damage or deterioration, and may result in injury by explosion or combustion.
In addition, do not use any device that is applied the current with inserting in the wrong orientation or incorrectly even just one time.

Points to remember on handling of ICs**(1) Over current Protection Circuit**

Over current protection circuits (referred to as current limiter circuits) do not necessarily protect ICs under all circumstances. If the Over current protection circuits operate against the over current, clear the over current status immediately.

Depending on the method of use and usage conditions, such as exceeding absolute maximum ratings can cause the over current protection circuit to not operate properly or IC breakdown before operation. In addition, depending on the method of use and usage conditions, if over current continues to flow for a long time after operation, the IC may generate heat resulting in breakdown.

(2) Thermal Shutdown Circuit

Thermal shutdown circuits do not necessarily protect ICs under all circumstances. If the thermal shutdown circuits operate against the over temperature, clear the heat generation status immediately.

Depending on the method of use and usage conditions, such as exceeding absolute maximum ratings can cause the thermal shutdown circuit to not operate properly or IC breakdown before operation.

(3) Heat Radiation Design

In using an IC with large current flow such as power amp, regulator or driver, please design the device so that heat is appropriately radiated, not to exceed the specified junction temperature (T_j) at any time and condition. These ICs generate heat even during normal use. An inadequate IC heat radiation design can lead to decrease in IC life, deterioration of IC characteristics or IC breakdown. In addition, please design the device taking into consideration the effect of IC heat radiation with peripheral components.

(4) Back-EMF

When a motor rotates in the reverse direction, stops or slows down abruptly, a current flow back to the motor's power supply due to the effect of back-EMF. If the current sink capability of the power supply is small, the device's motor power supply and output pins might be exposed to conditions beyond maximum ratings. To avoid this problem, take the effect of back-EMF into consideration in system design.

RESTRICTIONS ON PRODUCT USE

070122EBA_R6

- The information contained herein is subject to change without notice. 021023_D
- TOSHIBA is continually working to improve the quality and reliability of its products. Nevertheless, semiconductor devices in general can malfunction or fail due to their inherent electrical sensitivity and vulnerability to physical stress. It is the responsibility of the buyer, when utilizing TOSHIBA products, to comply with the standards of safety in making a safe design for the entire system, and to avoid situations in which a malfunction or failure of such TOSHIBA products could cause loss of human life, bodily injury or damage to property.
In developing your designs, please ensure that TOSHIBA products are used within specified operating ranges as set forth in the most recent TOSHIBA products specifications. Also, please keep in mind the precautions and conditions set forth in the "Handling Guide for Semiconductor Devices," or "TOSHIBA Semiconductor Reliability Handbook" etc. 021023_A
- The TOSHIBA products listed in this document are intended for usage in general electronics applications (computer, personal equipment, office equipment, measuring equipment, industrial robotics, domestic appliances, etc.). These TOSHIBA products are neither intended nor warranted for usage in equipment that requires extraordinarily high quality and/or reliability or a malfunction or failure of which may cause loss of human life or bodily injury ("Unintended Usage"). Unintended Usage include atomic energy control instruments, airplane or spaceship instruments, transportation instruments, traffic signal instruments, combustion control instruments, medical instruments, all types of safety devices, etc. Unintended Usage of TOSHIBA products listed in this document shall be made at the customer's own risk. 021023_B
- The products described in this document shall not be used or embedded to any downstream products of which manufacture, use and/or sale are prohibited under any applicable laws and regulations. 060106_Q
- The information contained herein is presented only as a guide for the applications of our products. No responsibility is assumed by TOSHIBA for any infringements of patents or other rights of the third parties which may result from its use. No license is granted by implication or otherwise under any patents or other rights of TOSHIBA or the third parties. 070122_C
- Please use this product in compliance with all applicable laws and regulations that regulate the inclusion or use of controlled substances.
Toshiba assumes no liability for damage or losses occurring as a result of noncompliance with applicable laws and regulations. 060819_AF
- The products described in this document are subject to foreign exchange and foreign trade control laws. 060925_E