

### Description

AH292 is a monolithic fan motor controller with Hall sensor's capability. It contains two complementary open-collector transistors for motor's coil driving, automatic lock current shutdown, and recovery protections. In addition a Frequency generator (FG) output is also available for speed detection.

Rotor-lock shutdown detection circuit turns off the output driver when the rotor is blocked to avoid coil overheat. Then, the automatic recovery circuit will restart the motor. These protected actions are repeated and periodic during the blocked period. Until the blocking is removed, the motor recovers and runs normally.

The AH292 is available in SOT89-5L package.

### Pin Assignments

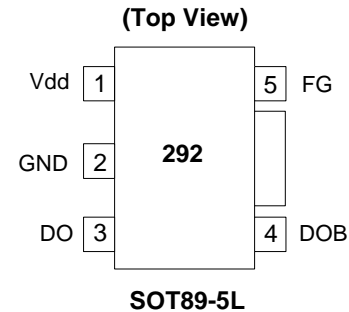

### Features

- On Chip Hall Sensor
- Rotor-Locked Shutdown
- Automatically Restart
- Frequency Generator (FG) Output
- Built-in Zener Protection for Output Driver
- Operating Voltage: 1.8V to 5.75V
- Output Current:  $I_{O(AVE)} = 400\text{mA}$
- Packaged in SOT89-5L
- Green Molding Compound

### Applications

- Two-coil BLDC cooling fans
- Low to medium voltage, low power BLDC motors

### Typical Application Circuit (Note 1)

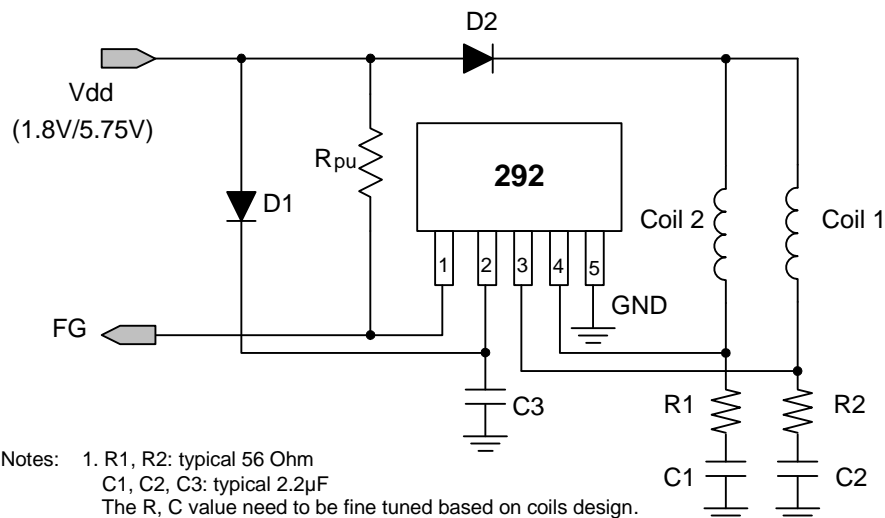

**1.8V/5.75V DC Brush-less Fan with FG output function**

**Pin Descriptions**

| Pin Name | Description          |
|----------|----------------------|
| FG       | Frequency Generation |
| Vdd      | Input Power          |
| DO       | Output Pin           |
| DOB      | Output Pin           |
| GND      | Ground               |

**Functional Block Diagram**

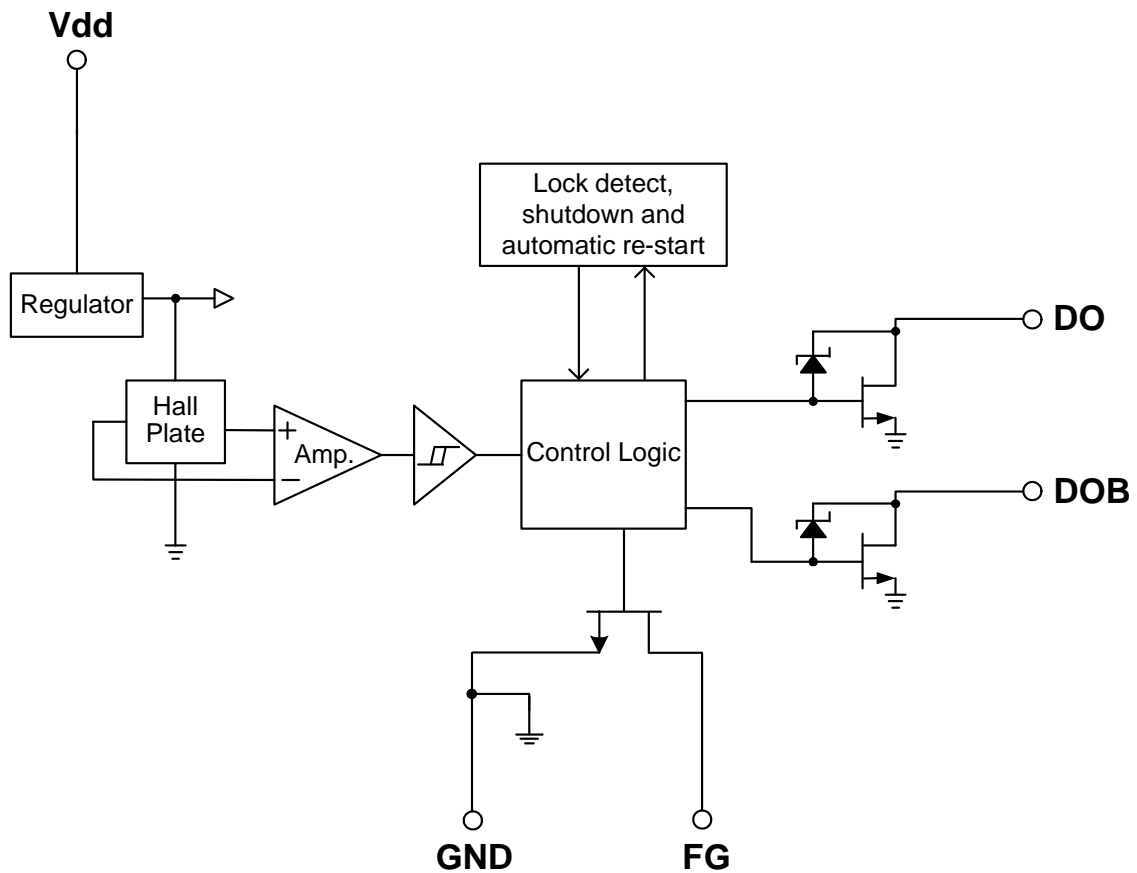

### Absolute Maximum Ratings (T<sub>A</sub> = 25°C)

| Symbol               | Characteristics              | Rating    | Unit |
|----------------------|------------------------------|-----------|------|
| V <sub>DD</sub>      | Operating Supply Voltage     | 8         | V    |
| I <sub>O(AVE)</sub>  | Output Current               | 400       | mA   |
| I <sub>O(PEAK)</sub> | Output Current               | 700       | mA   |
| P <sub>D</sub>       | Power Dissipation            | 800       | mW   |
| T <sub>ST</sub>      | Storage Temperature          | -55 ~ 150 | °C   |
| T <sub>J</sub>       | Maximum Junction Temperature | 150       | °C   |

### Recommended Operating Conditions

| Symbol          | Characteristic                | Conditions | Min | Max  | Unit |
|-----------------|-------------------------------|------------|-----|------|------|
| V <sub>DD</sub> | Supply Voltage (Note 2)       | Operating  | 1.8 | 5.75 | V    |
| T <sub>A</sub>  | Operating Ambient Temperature | Operating  | -20 | 100  | °C   |

Notes: 2. The output of IC will be switched after the supply voltage is over 1.8V, but the magnetic characteristics won't be normal until the supply is over 2.0V.

### Electrical Characteristics (T<sub>A</sub> = 25 °C, V<sub>DD</sub> = 5V, unless otherwise specified)

| Symbol                | Characteristics                | Conditions             | Min | Typ. | Max | Unit |
|-----------------------|--------------------------------|------------------------|-----|------|-----|------|
| I <sub>DD</sub>       | Supply current                 | Operating              | -   | 2.6  | 4.0 | mA   |
| T <sub>RLP-ON</sub>   | Rotor Lock Protection On Time  |                        | -   | 0.4  | -   | Sec  |
| T <sub>RLP-OFF</sub>  | Rotor Lock Protection Off Time |                        | 2.4 | 3    | 3.6 | Sec  |
| V <sub>OUT(SAT)</sub> | Output Saturation Voltage      | I <sub>O</sub> = 180mA | -   | 300  | -   | mV   |
|                       |                                | I <sub>O</sub> = 350mA | -   | 600  | -   | mV   |
| R <sub>DS(ON)</sub>   | Output On Resistance           |                        | -   | 1.75 | -   | ohm  |
| V <sub>OL</sub>       | FG Output V <sub>ds</sub>      | I <sub>O</sub> = 10mA  | -   | 0.5  | -   | V    |
| V <sub>Z</sub>        | Output Zener-Breakdown Voltage |                        | -   | 15   | -   | V    |

### Truth Table

| IN- | IN+ | CT | OUT1 | OUT2 | FG | Mode                        |
|-----|-----|----|------|------|----|-----------------------------|
| H   | L   | L  | H    | L    | H  | Rotating                    |
| L   | H   | L  | L    | H    | L  | Rotating                    |
| -   | -   | H  | off  | off  | -  | Lockup protection activated |

**Magnetic Characteristics** ( $T_A = 25\text{ }^\circ\text{C}$ ,  $V_{dd} = 5\text{V}$ , unless otherwise specified, Note 3)

(1mT = 10 Gauss)

| Symbol | Characteristics | Min | Typ. | Max | Unit  |
|--------|-----------------|-----|------|-----|-------|
| Bop    | Operation Point | 10  | 30   | 60  | Gauss |
| Brp    | Release Point   | -60 | -30  | -10 | Gauss |
| Bhy    | Hysteresis      | -   | 60   | -   | Gauss |

Notes: 3. The magnetic characteristics may vary with supply voltage, operating temperature and after soldering.

**Operating Characteristics**

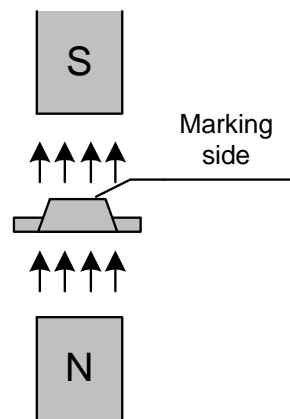
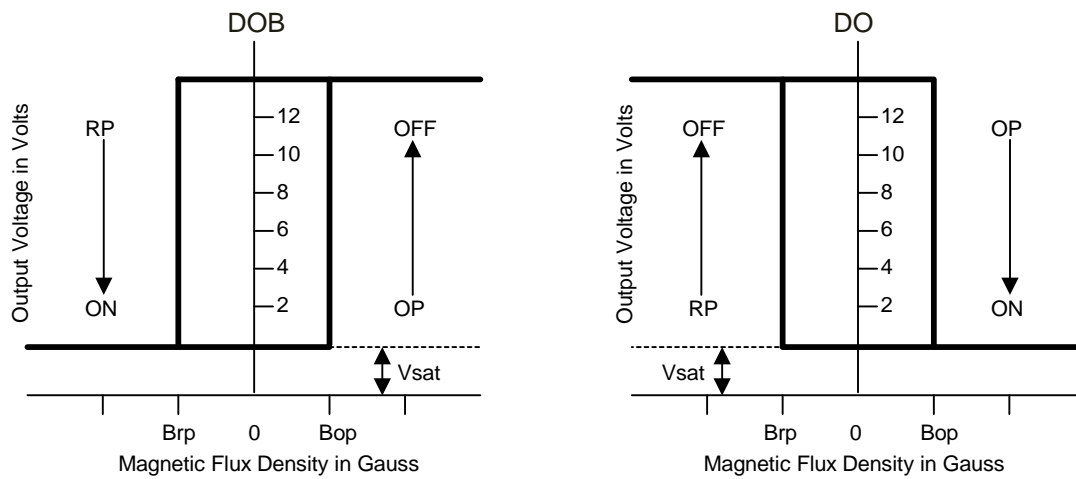

( SOT89-5L )

**Performance Characteristics**

|                           |            |            |            |            |            |            |            |            |            |            |
|---------------------------|------------|------------|------------|------------|------------|------------|------------|------------|------------|------------|
| <b>T<sub>A</sub> (°C)</b> | <b>25</b>  | <b>50</b>  | <b>60</b>  | <b>70</b>  | <b>75</b>  | <b>80</b>  | <b>85</b>  | <b>90</b>  | <b>95</b>  | <b>100</b> |
| P <sub>D</sub> (mW)       | 800        | 640        | 576        | 512        | 480        | 448        | 416        | 384        | 352        | 320        |
| <b>T<sub>A</sub> (°C)</b> | <b>105</b> | <b>110</b> | <b>115</b> | <b>120</b> | <b>125</b> | <b>130</b> | <b>135</b> | <b>140</b> | <b>145</b> | <b>150</b> |
| P <sub>D</sub> (mW)       | 288        | 256        | 224        | 192        | 160        | 128        | 96         | 64         | 32         | 0          |

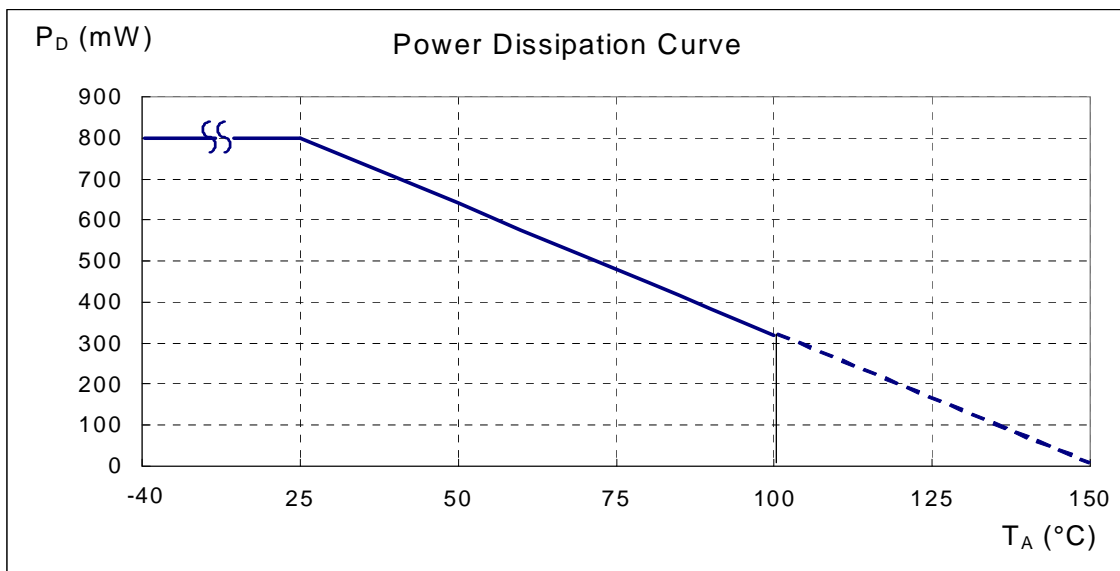

**Ordering Information**

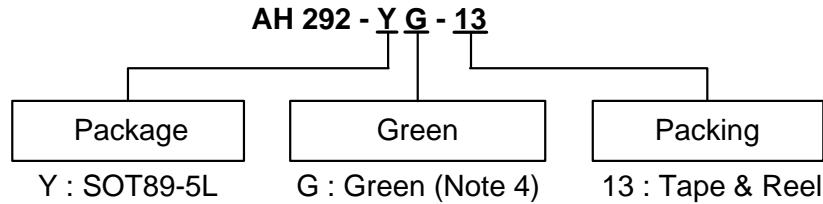

| Device      | Package Code | Packaging (Note 5, 6) | Bulk     |                    | 13" Tape and Reel |                    |
|-------------|--------------|-----------------------|----------|--------------------|-------------------|--------------------|
|             |              |                       | Quantity | Part Number Suffix | Quantity          | Part Number Suffix |
| AH292-YG-13 | Y            | SOT89-5L              | NA       | NA                 | 2500/Tape & Reel  | -13                |



- Notes: 4. EU Directive 2002/95/EC (RoHS). All applicable RoHS exemptions applied. Please visit our website at [http://www.diodes.com/products/lead\\_free.html](http://www.diodes.com/products/lead_free.html).
5. Pad layout as shown on Diodes Inc. suggested pad layout document AP02001, which can be found on our website at <http://www.diodes.com/datasheets/ap02001.pdf>.
6. Reverse taping as shown on Diodes Inc. Surface Mount (SMD) Packaging document AP02007, which can be found on our website <http://www.diodes.com/datasheets/ap02007.pdf>.

**Marking Information**

**(Top View)**

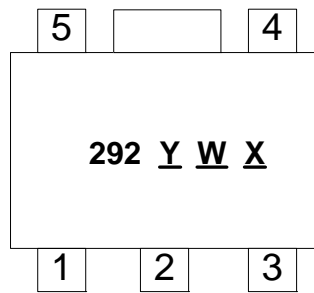

- Y : Year : 0~9
- W : Week : A~Z : 1~26 week;  
a~z : 27~52 week;  
z represents 52 and 53 week
- X : Internal code  
A~Z : Green

**SOT89-5L**

**Package Outline Dimensions (All Dimensions in mm)**

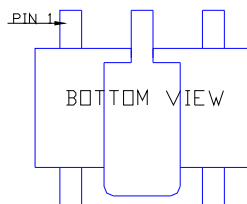
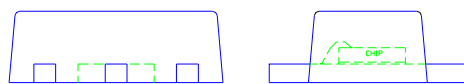
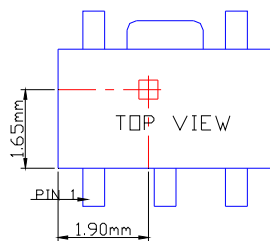
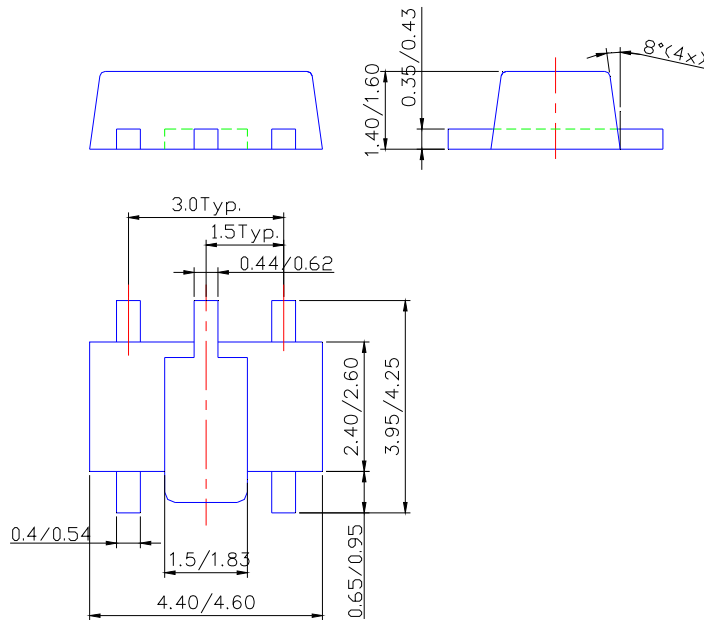

**Sensor Location**

**IMPORTANT NOTICE**

DIODES INCORPORATED MAKES NO WARRANTY OF ANY KIND, EXPRESS OR IMPLIED, WITH REGARDS TO THIS DOCUMENT, INCLUDING, BUT NOT LIMITED TO, THE IMPLIED WARRANTIES OF MERCHANTABILITY AND FITNESS FOR A PARTICULAR PURPOSE (AND THEIR EQUIVALENTS UNDER THE LAWS OF ANY JURISDICTION).

Diodes Incorporated and its subsidiaries reserve the right to make modifications, enhancements, improvements, corrections or other changes without further notice to this document and any product described herein. Diodes Incorporated does not assume any liability arising out of the application or use of this document or any product described herein; neither does Diodes Incorporated convey any license under its patent or trademark rights, nor the rights of others. Any Customer or user of this document or products described herein in such applications shall assume all risks of such use and will agree to hold Diodes Incorporated and all the companies whose products are represented on Diodes Incorporated website, harmless against all damages.

Diodes Incorporated does not warrant or accept any liability whatsoever in respect of any products purchased through unauthorized sales channel.

Should Customers purchase or use Diodes Incorporated products for any unintended or unauthorized application, Customers shall indemnify and hold Diodes Incorporated and its representatives harmless against all claims, damages, expenses, and attorney fees arising out of, directly or indirectly, any claim of personal injury or death associated with such unintended or unauthorized application.

Products described herein may be covered by one or more United States, international or foreign patents pending. Product names and markings noted herein may also be covered by one or more United States, international or foreign trademarks.

**LIFE SUPPORT**

Diodes Incorporated products are specifically not authorized for use as critical components in life support devices or systems without the express written approval of the Chief Executive Officer of Diodes Incorporated. As used herein:

A. Life support devices or systems are devices or systems which:

1. are intended to implant into the body, or
2. support or sustain life and whose failure to perform when properly used in accordance with instructions for use provided in the labeling can be reasonably expected to result in significant injury to the user.

B. A critical component is any component in a life support device or system whose failure to perform can be reasonably expected to cause the failure of the life support device or to affect its safety or effectiveness.

Customers represent that they have all necessary expertise in the safety and regulatory ramifications of their life support devices or systems, and acknowledge and agree that they are solely responsible for all legal, regulatory and safety-related requirements concerning their products and any use of Diodes Incorporated products in such safety-critical, life support devices or systems, notwithstanding any devices- or systems-related information or support that may be provided by Diodes Incorporated. Further, Customers must fully indemnify Diodes Incorporated and its representatives against any damages arising out of the use of Diodes Incorporated products in such safety-critical, life support devices or systems.

Copyright © 2010, Diodes Incorporated

[www.diodes.com](http://www.diodes.com)