

Dual Full Bridge Low Voltage Motor Driver

Features and Benefits

- Low $R_{DS(on)}$ outputs
- Full- and half-stepping capability
- Small package
- Forward, reverse, and brake modes for DC motors
- Sleep mode with zero current drain
- PWM control up to 250 kHz
- Crossover-current protection
- Thermal shutdown (TSD)

Package: 10 Contact DFN (suffix EJ)

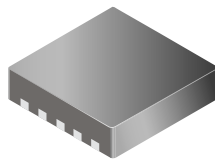

Approximate Scale 1:1

Description

The A3901 is a dual full-bridge motor driver, designed for low voltage portable applications involving bipolar stepper or brush DC motors. The outputs have been optimized for low voltage drop, with currents up to ± 400 mA (± 800 mA with outputs paralleled) and an operating voltage range of 2.5 to 5.5 V.

The four inputs (IN1 to IN4) can control a bipolar stepper motor in full- or half-step mode, or DC motors in forward, reverse, or brake mode. The inputs can be PWMed for current or speed control at frequencies up to 250 kHz.

Internal protection circuitry includes thermal shut down (TSD) and crossover (shoot-through) protection.

The A3901 is supplied in a 3 mm x 3 mm x 0.75 mm nominal height, 10-lead DFN package, with exposed thermal pad (package "EJ"). This small footprint package is lead (Pb) free, with 100% matte tin leadframe plating.

Typical Application

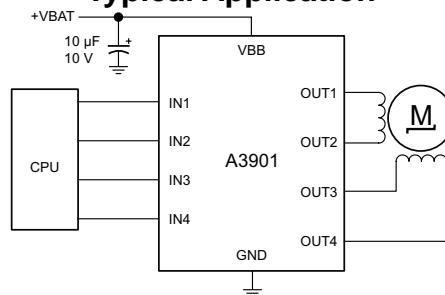

Figure 1. Typical stepper motor control

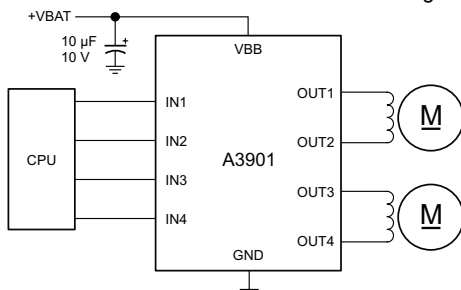

Figure 2. Typical dual DC motor control

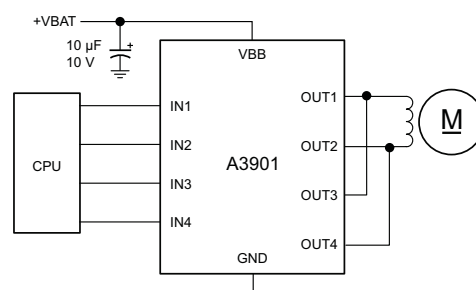

Figure 3. Typical single DC motor control (paralleled outputs)

Selection Guide

Part Number	Packing
A3901SEJTR-T	Tape and reel, 1500 pieces/reel

Absolute Maximum Ratings

Parameter	Symbol	Conditions	Min.	Typ.	Max.	Units
Load Supply Voltage	V_{BB}		–	–	7	V
Output Current per Channel*	I_{OUT}		–	–	400	mA
Logic Input Voltage Range	V_{IN}		–0.3	–	6	V
Junction Temperature	T_J		–	–	150	°C
Storage Temperature Range	T_{stg}		–55	–	150	°C
Operating Temperature Range	T_A		–20	–	85	°C

*Output current rating may be limited by duty cycle, ambient temperature, and heat sinking. Under any set of conditions, do not exceed the specified current rating or a junction temperature of 150°C.

Functional Block Diagram

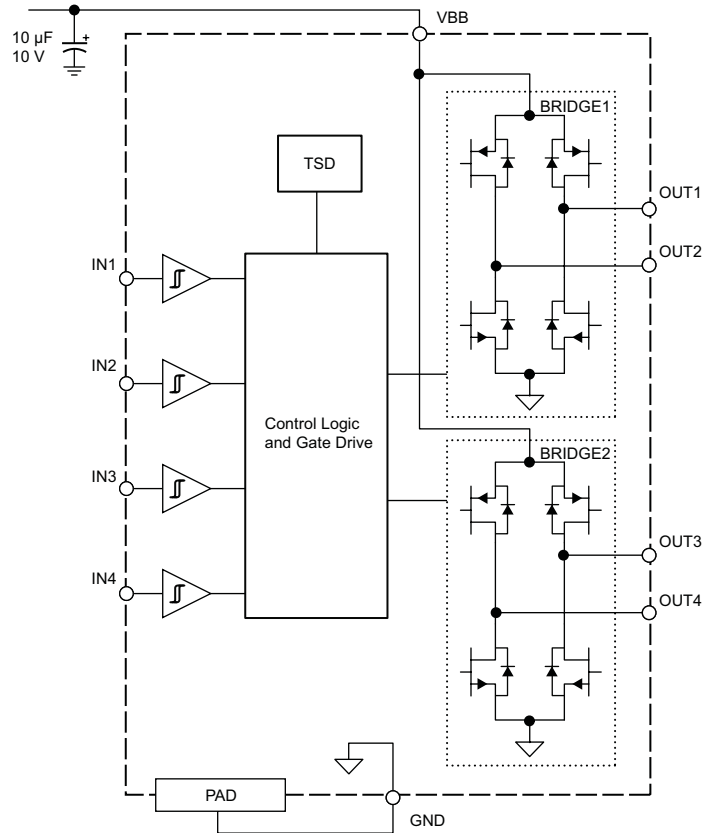

Terminal Diagram

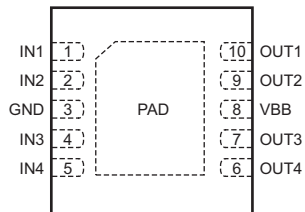

Number	Name	Description
1	IN1	Logic input 1
2	IN2	Logic input 2
3	GND	Ground terminal
4	IN3	Logic input 3
5	IN4	Logic input 4
6	OUT4	Bridge2 output to load
7	OUT3	Bridge2 output to load
8	VBB	Load supply terminal
9	OUT2	Bridge1 output to load
10	OUT1	Bridge1 output to load
–	Pad	Exposed pad for thermal dissipation; connect to GND externally

ELECTRICAL CHARACTERISTICS at $T_A=25^\circ\text{C}$, and $V_{BB} = 2.5$ to 5.5 V, unless noted otherwise

Characteristics	Symbol	Test Conditions	Min.	Typ.	Max.	Units
Output On Resistance	$R_{DS(on)}$	Source driver, $V_{BB} = 3$ V, $I_{OUT} = 300$ mA	–	1.8	2.1	Ω
		Source driver, $V_{BB} = 5$ V, $I_{OUT} = 300$ mA	–	1.2	1.4	Ω
		Sink driver, $V_{BB} = 3$ V, $I_{OUT} = 300$ mA	–	1.2	1.4	Ω
		Sink driver, $V_{BB} = 5$ V, $I_{OUT} = 300$ mA	–	0.8	1.0	Ω
Clamp Diode		$I = 300$ mA	–	–	1.5	V
Motor Supply Current	I_{BB}	All outputs PWMed at 20 kHz	–	0.6	–	mA
		Sleep mode, $V_{BB} = 3$ V	–	–	100	nA
		Sleep mode, $V_{BB} = 5$ V	–	<50	500	nA
Logic Input Voltage	$V_{IN(1)}$		$V_{BB}/2$	–	–	V
	$V_{IN(0)}$		–	–	0.5	V
Logic Input Current	$I_{IN(1)}$	$V_{IN} = 2.0$ V	–	<100	500	nA
	$I_{IN(0)}$	$V_{IN} = 0.5$ V	–	<–100	–500	nA
Input Voltage Hysteresis	V_{hys}		–	150	–	mV
Propagation Delay	$t_{pd(on)}$	Input Low to Sink On, Input High to Source On	–	130	–	ns
	$t_{pd(off)}$	Input High to Sink Off, Input Low to Source Off	–	50	–	ns
Crossover Delay	t_{COD}		–	80	–	ns
Thermal Shut Down Temperature	T_J		–	150	–	$^\circ\text{C}$
Thermal Shut Down Hysteresis	T_{Jhys}		–	10	–	$^\circ\text{C}$

THERMAL CHARACTERISTICS

Characteristics	Symbol	Test Conditions	Rating	Unit
Package Thermal Resistance*	$R_{\theta JA}$	Measured on 4-layer board based on JEDEC standard	45	$^\circ\text{C}/\text{W}$
		Measured on 2-layer board with copper limited to solder pads and 0.88 in ² . of copper on each side	65	$^\circ\text{C}/\text{W}$

*Additional thermal information is available on the Allegro Web site.

Motor Operation Truth Table

INx ¹				OUT1 ²	OUT2	OUT3	OUT4	Function	
Stepper Motor									
IN1	IN2	IN3	IN4					Full Stepping	Half-Stepping
0	0	0	0	OFF	OFF	OFF	OFF	Sleep Mode	Sleep Mode
1	0	1	0	H	L	H	L	Step 1	Step 1
0	0	1	0	OFF	OFF	H	L	–	Step 2
0	1	1	0	L	H	H	L	Step 2	Step 3
0	1	0	0	L	H	OFF	OFF	–	Step 4
0	1	0	1	L	H	L	H	Step 3	Step 5
0	0	0	1	OFF	OFF	L	H	–	Step 6
1	0	0	1	H	L	L	H	Step 4	Step 7
1	0	0	0	H	L	OFF	OFF	–	Step 8
DC Motor (Dual)									
IN1 or IN3		IN2 or IN4							
0		0		OFF	OFF	OFF	OFF	Hi-Z (Sleep Mode)/Coast	
1		0		H	L	H	L	Forward	
0		1		L	H	L	H	Reverse	
1		1		L	L	L	L	Brake	
DC Motor (Single, Paralleled)									
IN1 and IN3		IN2 and IN4							
0		0		OFF	OFF	OFF	OFF	Hi-Z (Sleep Mode)/Coast	
1		0		H	L	H	L	Forward	
0		1		L	H	L	H	Reverse	
1		1		L	L	L	L	Brake	
DC Motor (External PWM)									
IN1 or IN3		IN2 or IN4							
1		0		H	L	H	L	Forward	
0		0		OFF	OFF	OFF	OFF	Fast Decay	
0		1		L	H	L	H	Reverse	
0		0		OFF	OFF	OFF	OFF	Fast Decay	
1		0		H	L	H	L	Forward	
1		1		L	L	L	L	Slow Decay	
0		1		L	H	L	H	Reverse	
1		1		L	L	L	L	Slow Decay	

¹0 = logic low, $V_{INx} < V_{IN(0)(max)}$; 1 = logic high, $V_{INx} > V_{IN(1)(min)}$

²H = voltage high, source driver on; L = voltage low, sink driver on

Characteristic Performance

Output On Resistance versus Load Supply Voltage
 $I_{OUT} = 100\text{ mA}$

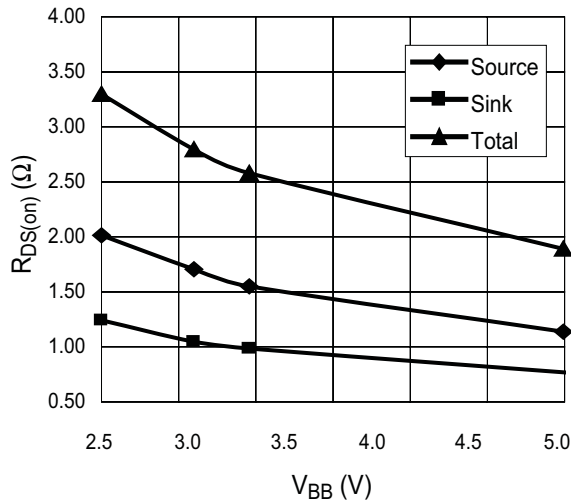

Output On Resistance versus Load Supply Voltage
 $I_{OUT} = 300\text{ mA}$

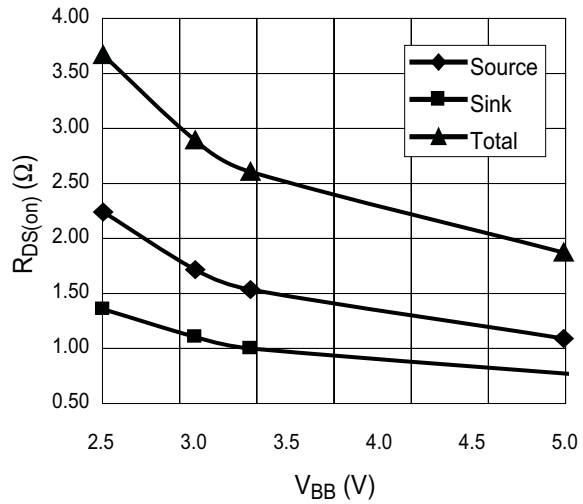

Output On Resistance versus Output Current
 $V_{BB} = 3\text{ V}$

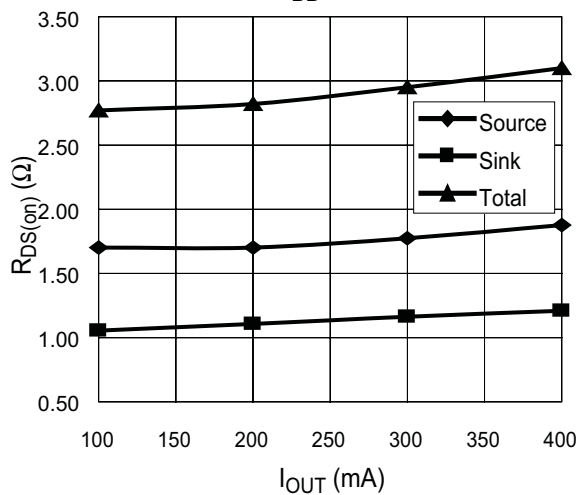

Output On Resistance versus Output Current
 $V_{BB} = 5\text{ V}$

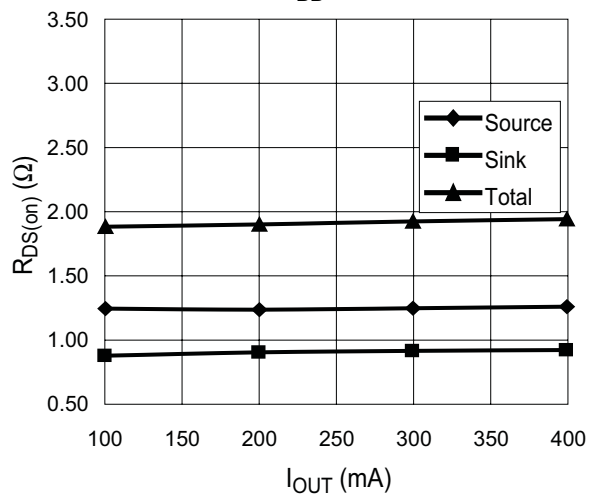

Functional Description

Device Operation. The A3901 is a dual full-bridge low voltage motor driver capable of operating one stepper motor or up to two DC motors. MOSFET output stages substantially reduce the voltage drop and the power dissipation of the outputs of the A3901 compared to typical drivers with bipolar transistors.

Internal circuit protection includes thermal shutdown with hysteresis, clamp diodes, and crossover current protection.

The A3901 is designed for portable applications with a power-off (Sleep mode) current of 50 nA typical, and an operating voltage of 2.5 to 5.5 V. The A3901 logic inputs are 3 to 5 V logic compatible.

Output current can be regulated by pulse width modulating (PWM) the inputs. The full-bridge outputs can be paralleled for higher-current applications (see figure 6).

In conditions where the logic supply voltage drops below 2.5 V, both the sink and the source $R_{DS(on)}$ will increase beyond the specified values. In extreme cases, no power will be delivered to the motor(s). However, the device will not be damaged.

In stepping operation, the device can drive in either full- or half-step mode. The stepping mode is set by

the signal pattern on the IN_x terminals, as shown in the stepping timing diagrams.

External PWM. Pulse width modulating the inputs allows the output current to be regulated. Slow decay mode is achieved by holding one input high while PWMing the other input. Holding one input low and PWMing the other input results in fast decay. See the External PWM diagram.

Sleep Mode. Pulling all inputs to 0.5 V or less, sends the A3901 into Sleep mode, during which it draws 50 nA typical.

Thermal Shutdown. The A3901 will disable the outputs if the junction temperature reaches 165°C. When thermal shutdown is entered, after the junction temperature drops 15°C, the outputs will be re-enabled.

Brake Mode. When driving DC motors, the A3901 will go into Brake mode (turn on both sink drivers) when all inputs, IN_x , are logic 1. There is no protection during braking, so care must be taken to ensure that the peak current during braking does not exceed the absolute maximum current.

Application Information

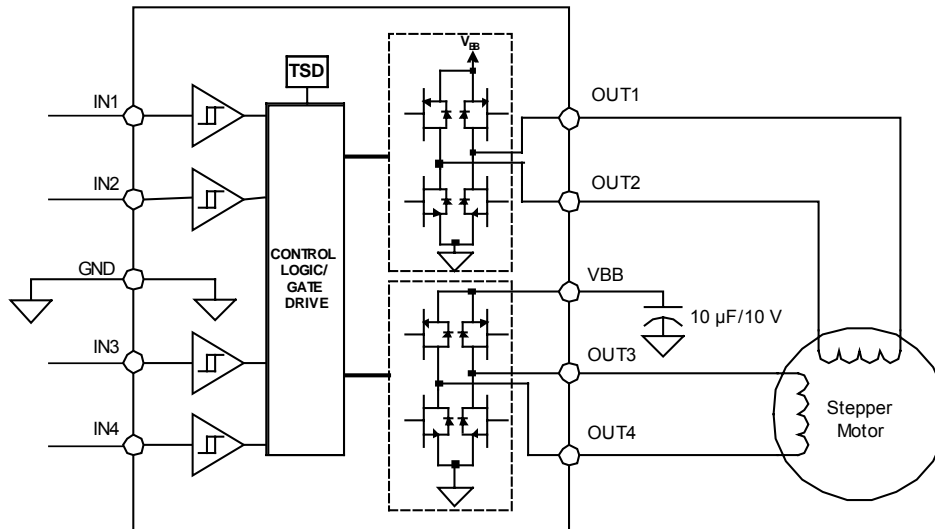

Figure 4a. Typical stepper motor control application

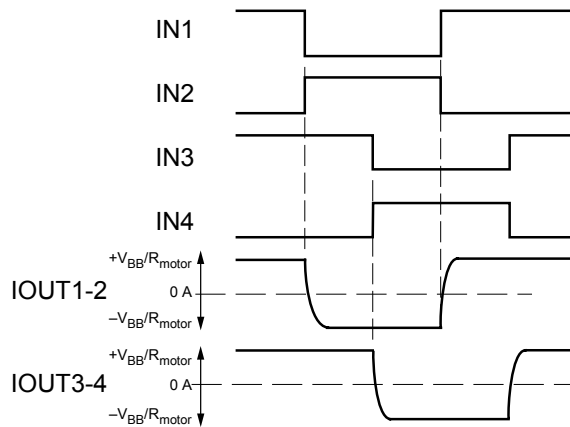

Figure 4b. Full step mode timing chart

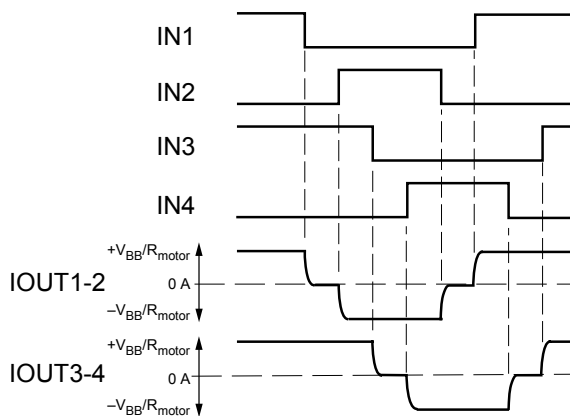

Figure 4c. Half step mode timing chart

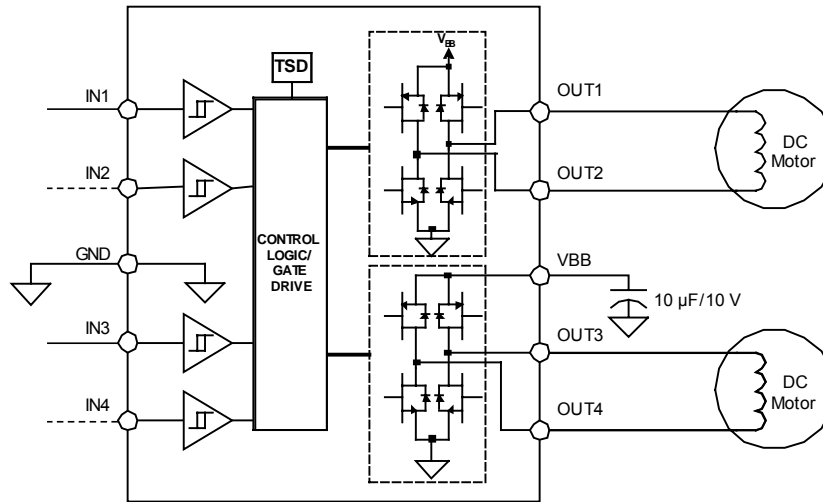

Figure 5. Typical dual DC motor control application. Either IN1 or IN2 can be used to drive OUT1 and OUT2. Either IN3 or IN4 can be used to drive OUT3 and OUT4.

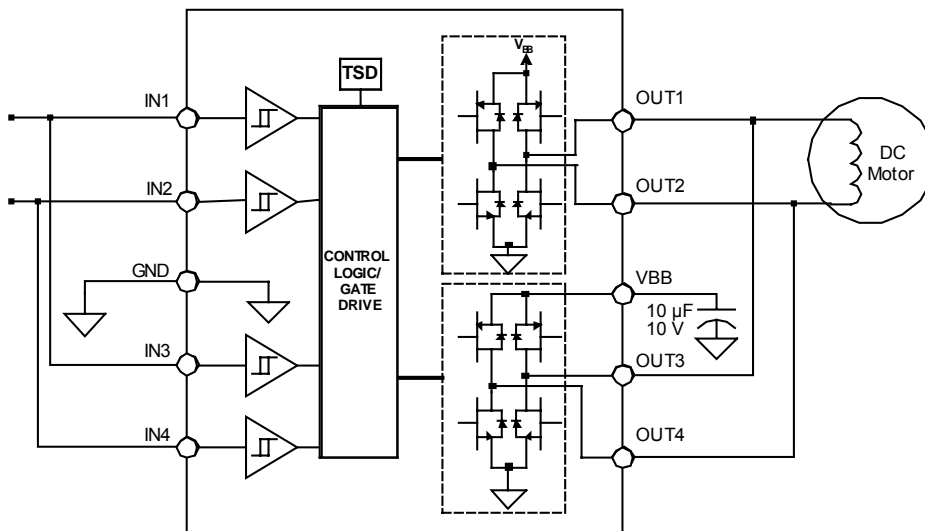

Figure 6. Typical single DC motor control (paralleled outputs)

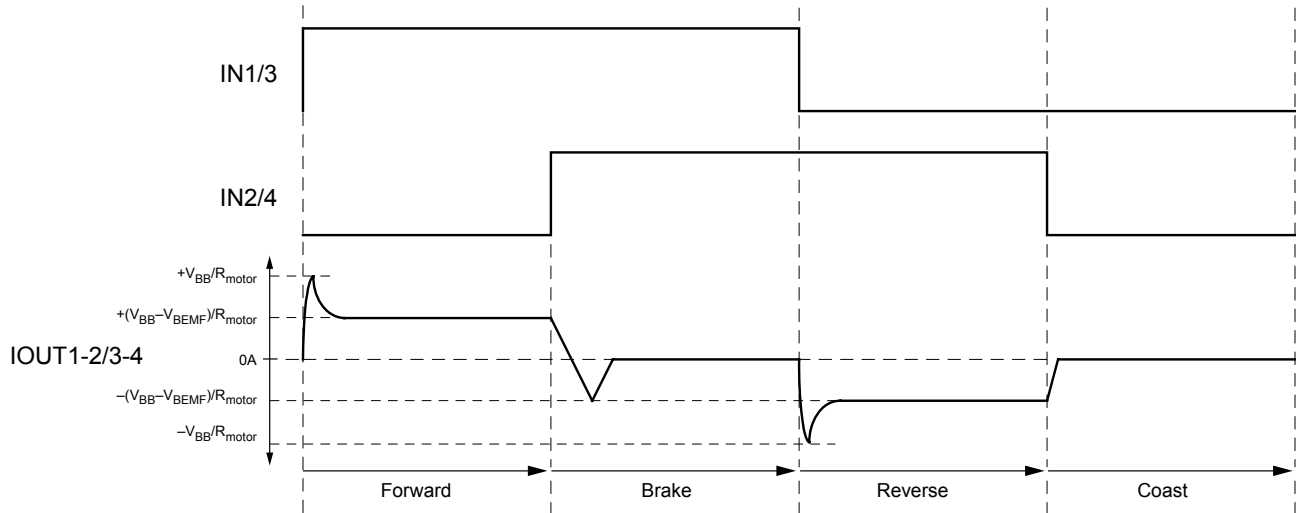

Figure 7. Typical dual DC motor control application

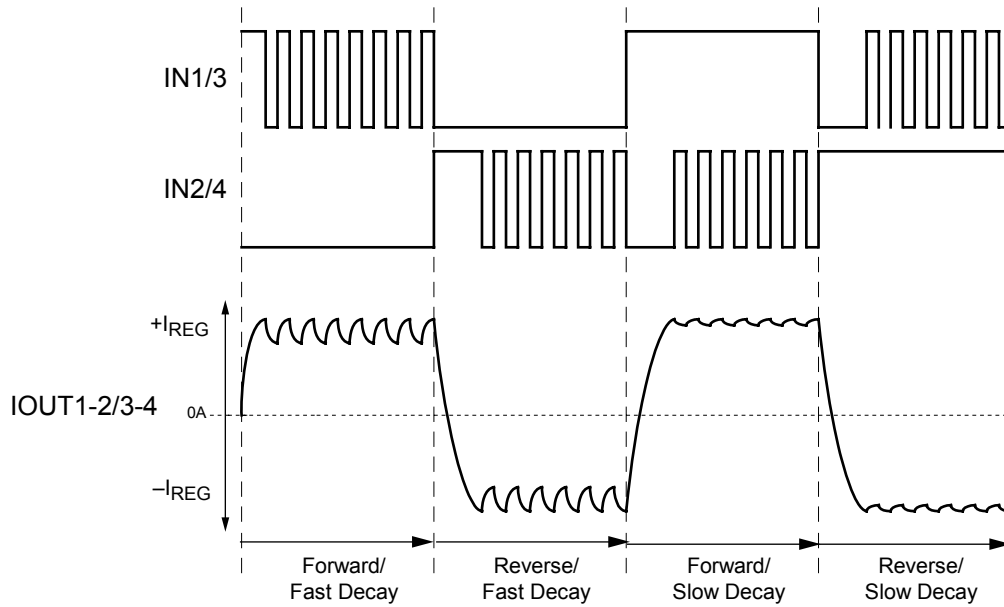
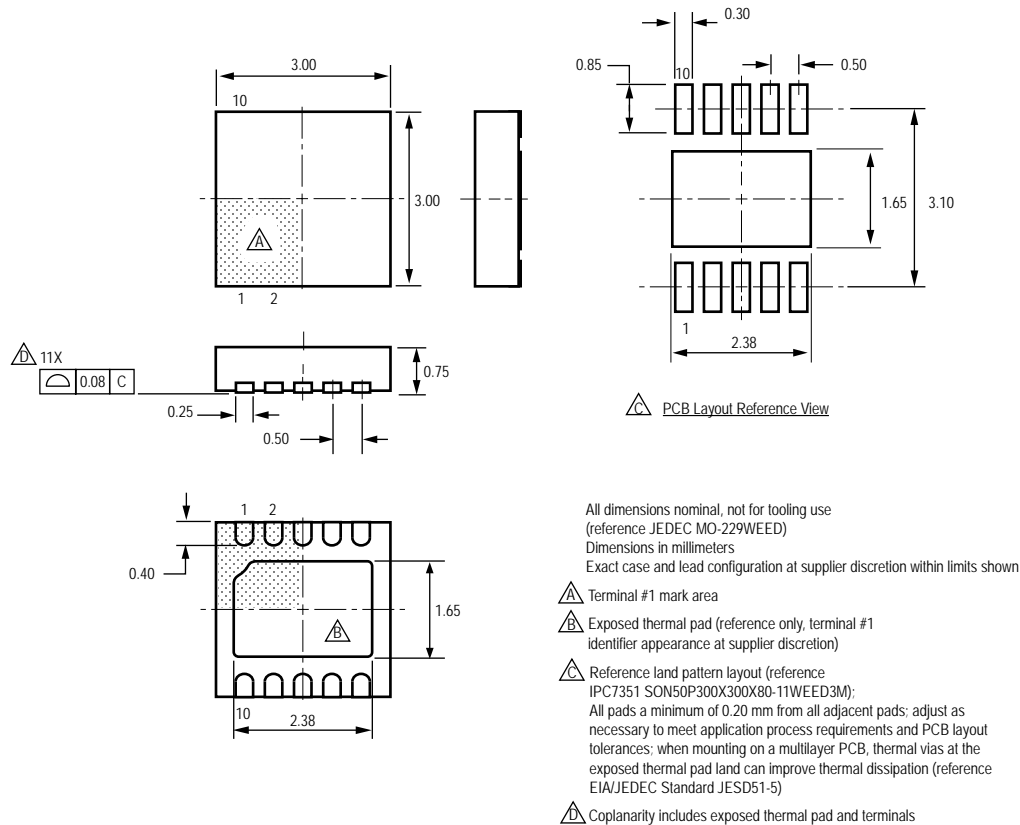

Figure 8. External PWM current control in fast and slow decay modes

Package EJ, 10-contact DFN



Copyright ©2005,2007, Allegro MicroSystems, Inc.

The products described here are manufactured under one or more U.S. patents or U.S. patents pending.

Allegro MicroSystems, Inc. reserves the right to make, from time to time, such departures from the detail specifications as may be required to permit improvements in the performance, reliability, or manufacturability of its products. Before placing an order, the user is cautioned to verify that the information being relied upon is current.

Allegro's products are not to be used in life support devices or systems, if a failure of an Allegro product can reasonably be expected to cause the failure of that life support device or system, or to affect the safety or effectiveness of that device or system.

The information included herein is believed to be accurate and reliable. However, Allegro MicroSystems, Inc. assumes no responsibility for its use; nor for any infringement of patents or other rights of third parties which may result from its use.

For the latest version of this document, visit our website:

www.allegromicro.com



Allegro MicroSystems, Inc.
115 Northeast Cutoff
Worcester, Massachusetts 01615-0036 U.S.A.
1.508.853.5000; www.allegromicro.com