

ZXBM2001 ZXBM2002 ZXBM2003

VARIABLE SPEED 2-PHASE FAN MOTOR CONTROLLER

DESCRIPTION

The ZXBM200x is a series of 2-phase, DC brushless motor pre-drivers with PWM variable speed control suitable for fan and blower motors.

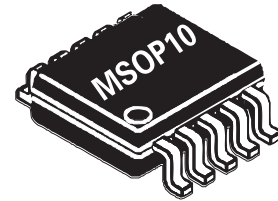

FEATURES

- Built in lock detect protection, rotational speed sensing and automatic recovery
- Built in Hall amplifier allows direct connection to Hall element
- PWM Speed control via
 - External voltage
 - Thermistor input
 - External PWM source
- Speed (FG) pulse output – ZXBM2003
- Rotor lock output – ZXBM2002
- Combined Rotor Lock (RD) and Speed (FG) signal – ZXBM2001
- Up to 18V input voltage (60V with external regulator)
- MSOP10 package

APPLICATIONS

- Mainframe and Personal Computer Fans and Blowers
- Instrumentation Fans
- Central Heating Blowers
- Automotive climate control

ORDERING INFORMATION

DEVICE	REEL SIZE	TAPE WIDTH	QUANTITY PER REEL
ZXBM200xX10TA	7" (180mm)	12mm	1,000
ZXBM200xX10TC	13" (330mm)	12mm	4,000

Example: ZXBM2001X10TA

DEVICE MARKING

ZXBM2001 or BM21

ZXBM2002 or BM22

ZXBM2003 or BM23

ISSUE 4 - OCTOBER 2004

ZXBM2001 ZXBM2002 ZXBM2003

Absolute maximum ratings

Parameter	Symbol	Limits	Unit
Supply Voltage	V_{CCmax}	-0.6 to 20	V
Input Current	I_{CCmax}	200	mA
Power Dissipation 25°C	P_{Dmax}	500	mW
Operating Temp.	T_{OPR}	-40 to 85	°C
Storage Temp.	T_{STG}	-55 to 150	°C

Power Dissipation

1) Maximum allowable Power Dissipation, P_D , is shown plotted against Ambient Temperature, T_A , in the accompanying Power Derating Curve, indicating the Safe Operating Area for the device.

2) Power consumed by the device, P_T , can be calculated from the equation:

$$P_T = P_Q + P_{Ph}$$

where P_Q is power dissipated under quiescent current conditions, given by:

$$P_Q = V_{CC} \times I_{CC}$$

where V_{CC} is the application device Supply Voltage

and I_{CC} is the maximum Supply Current given in the Electrical Characteristics

and P_{Ph} is power generated due to either one of the phase outputs Ph1 or Ph2 being active, given by:

$$P_{Ph} = I_{OL} \times V_{OL}$$

where I_{OL} is the application Ph1 and Ph2 output currents

and V_{OL} is the maximum Low Level Output Voltage for the Ph1 and Ph2 outputs given in the Electrical Characteristics

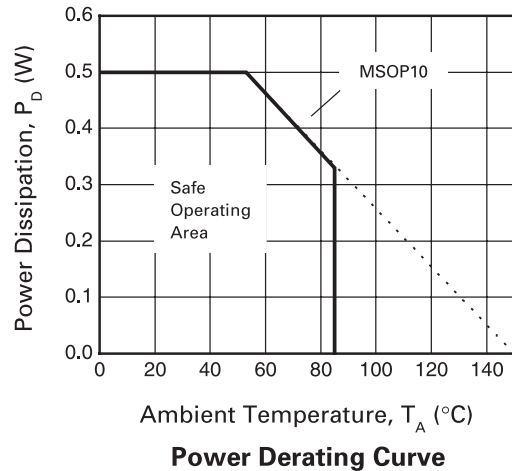

ZXBM2001 ZXBM2002 ZXBM2003

Electrical Characteristics (at $T_{amb} = 25^{\circ}\text{C}$ & $V_{CC} = 12\text{V}$)

Parameter	Symbol	Min	Typ	Max	Unit	Conditions
Supply Voltage	V_{CC}	4.5		18	V	
Supply Current	I_{CC}		2.2	3.25	mA	No Load ¹
Hall Amp Input Voltage		40			mV	diff p-p
Hall Amp Common Mode Voltage	V_{CM}	0.5	$0.5V_{CC}$	$V_{CC}-1.5$	V	
Hall Amp Input Offset	V_{OFS}		± 7		mV	
Hall Amp Bias Current	V_{BS}		-350		nA	
PH1, PH2 Output High	V_{OH}	$V_{CC}-2.2$	$V_{CC}-1.8$		V	$I_{OH} = 80\text{mA}$
PH1, PH2 Output Off Leakage Current	I_{OFF}			± 10	μA	
PH1, PH2 Output Current High	I_{OH}			-80	mA	
Lock/FG Maximum Collector Voltage	V_{OH}			V_{CC}	V	
Lock/FG Sink Current	I_{OL}			5	mA	
Lock/FG Low Level O/P Voltage	V_{OL}		0.3	0.5	V	$I_{OL} = 5\text{mA}$
C_{LCK} Charge Current	I_{LCKC}	-1.8	-2.8		μA	$V_{in} = 1.5\text{V}$
C_{LCK} Discharge Current	I_{LCKD}		0.28	0.35	μA	$V_{in} = 1.5\text{V}$
Lock condition On:Off ratio		1:7	1:10			
C_{LCK} High Threshold Voltage	V_{THH}		2.0		V	
C_{LCK} Low Threshold Voltage	V_{THL}		1.0		V	
C_{PWM} Charge Current	I_{PWMC}	3.6	4.3	5.0	μA	$V_{in} = 1.5\text{V}$
C_{PWM} Discharge Current	I_{PWMD}	50	62	75	μA	$V_{in} = 1.5\text{V}$
PWM Frequency	F_{PWM}		24 34		kHz kHz	$C_{PWM} = 150\text{pF}$ $C_{PWM} = 100\text{pF}$
C_{PWM} High Threshold Voltage	V_{THH}		2.0		V	
C_{PWM} Low Threshold Voltage	V_{THL}		1.0		V	
SPD Voltage Control Range	V_{SPD}	1		2	V	2
SPD Open Circuit Voltage			1.5		V	3

Notes:

¹ Measured with pins H+, H-, CLCK and CPWM = 0V and all other signal pins open circuit.

² The 1V minimum represents 100% PWM drive and 2V represents 0% PWM drive.

³ This voltage is determined by an internal resistor network of 52.5k Ω from the pin to Gnd and 19.5k Ω from the pin to a 2V reference. Whilst both resistors track each other the absolute values are subject to a $\pm 20\%$ manufacturing tolerance

ZXBM2001 ZXBM2002 ZXBM2003

Block Diagram (ZXBM2001):

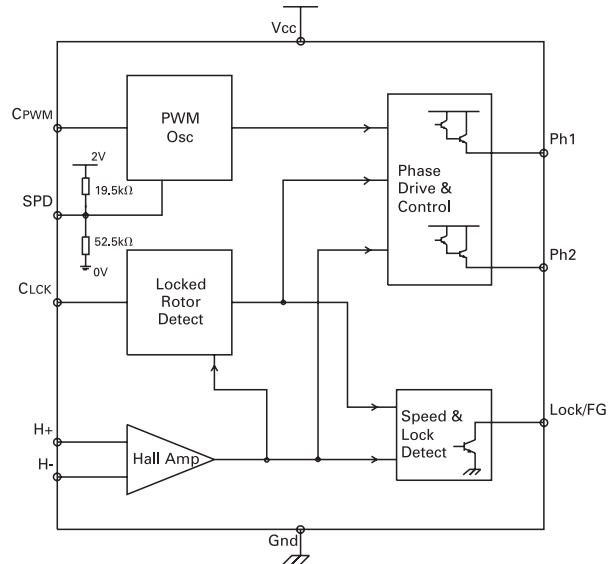

Pin Assignments

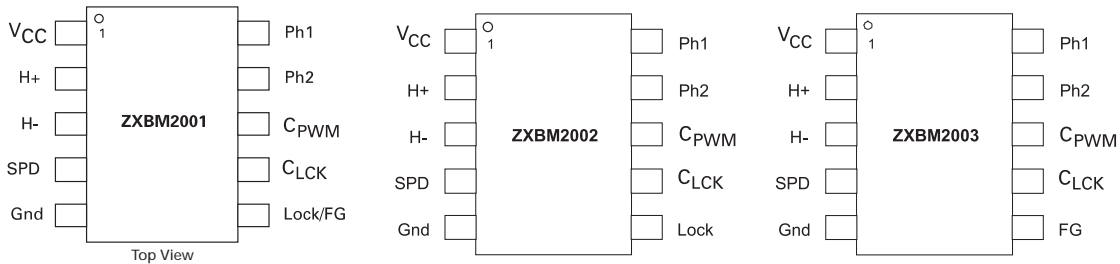

Pin Functional Descriptions

1. VCC - Applied voltage

This is the device supply voltage. For 5V to 12V fans this can be supplied directly from the Fan Motor supply. For fans likely to run in excess of the 18V maximum rating for the device this will be supplied from an external regulator such as a zener diode.

2. H+ - Hall input

3. H- - Hall input

The rotor position of the Fan Motor is detected by a Hall sensor whose output is applied to these pins. This sensor can be either a 4 pin 'naked' Hall device or a 3 pin buffered switching type. For a 4 pin device the differential Hall output signal is connected to the H+ and H- pins. For a 3 pin buffered Hall sensor the Hall device output is attached to the H+ pin whilst the H- pin has an external potential divider attached to hold the pin at half VCC. When H+ is high in relation to H- Ph2 is the active drive.

ZXBM2001 ZXBM2002 ZXBM2003

4. SPD - Speed control voltage input

This pin provides control over the Fan Motor speed by varying the Pulse Width Modulated (PWM) drive ratio at the Ph1 and Ph2 outputs. This control signal can take the form of either a voltage input of nominal range 2V to 1V, representing 0% to 100% drive respectively, or alternatively a thermistor can be attached to this pin to control the voltage. A third method of speed control is available by the application of an externally derived PWM signal and this will be discussed under the C_{PWM} pin.

This pin has an internal potential divider between an internal 2.0V reference and Gnd (see Block Diagram) designed to hold the pin at approximately 1.5V. This will represent a drive of nominally 50% PWM. For thermal speed control a 100k NTC thermistor is connected between the SPD and ground will provide a drive nominally 70% at 25°C and 100% at 50°C. As the thermistor is connected in parallel with the internal resistor the non-linearity of an NTC thermistor is largely taken out. A linearity of typically ±2.5% is achievable.

Lower values of thermistor can be used if needed and in this situation an external potential divider will be needed to set the speed range. This will take the form of a resistor from the SPD pin to V_{CC} and a resistor from the SPD pin to Gnd. Full details are given in the ZXBM200x series Application Note.

If speed control is not required this pin is can be left open circuit for 50% drive or tied to ground by a 10kΩ resistor to provide 100% drive.

If required this pin can also be used as an enable pin. The application of a voltage of 2.0V to V_{CC} will to force the PWM drive fully off, in effect disabling the drive.

5. GND - Ground

This is the device supply ground return pin and will generally be the most negative supply pin to the fan.

6. LOCK/FG - Locked Rotor error output / Frequency Generator (speed) output

This pin is an open collector output and so will require an external pull up resistor for correct operation.

On the ZXBM2001 the Lock/FG pin is designed to be a dual function pin to provide an indication of the Fans rotational speed together with an indication of when the Fan has failed rotating for whatever reason (Rotor Locked condition). Under correct operating conditions, and with the external pull-up in place, this pin will provide an output signal whose frequency will be twice that of the rotational frequency of the fan. Should the fan itself stop rotating for any reason, i.e. an obstruction in the fan blade or a seized bearing, then the device will enter a Rotor Locked condition. In this condition the Lock/FG pin will go high (regardless of the state of the Hall sensor) when the C_{LCK} pin reaches the V_{THH} threshold and will remain high until the fan blades start rotating again.

On the ZXBM2002 variant this pin is Lock. During normal operation the signal will be low and during a Locked Rotor condition the pin will go high when the C_{LCK} pin reaches the V_{THH} threshold.

For the ZXBM2003 variant this pin is FG. This signal is a buffered and inverted output of the Hall signal and therefore provides an output signal whose frequency will be twice that of the rotational frequency of the fan.

7. C_{LCK} - Locked Rotor timing capacitor

When in a Locked Rotor condition as described above the Ph1 and Ph2 drive outputs go into a safe drive mode to protect the external drive devices and the motor windings. This condition consists of driving the motor for a short period then waiting for a longer period before trying again. The frequency at which this takes place is determined by the size of the capacitor applied to this CLCK pin. For a 12V supply a value of 1.0uF will typically provide an 'On' (drive) period of 0.33s and an 'Off' (wait) period of 4.0s, giving an On:Off ratio of 1:12.

The C_{LCK} timing periods are determined by the following equations:

$$T_{\text{lock}} = \frac{V_{\text{THH}} \times C_{\text{LCK}}}{I_{\text{LCKC}}}$$

$$T_{\text{off}} = \frac{(V_{\text{THH}} - V_{\text{THL}}) \times C_{\text{LCK}}}{I_{\text{LCKD}}}$$

$$T_{\text{on}} = \frac{(V_{\text{THH}} - V_{\text{THL}}) \times C_{\text{LCK}}}{I_{\text{LCKC}}}$$

Where V_{THH} and V_{THL} are the C_{LCK} pin threshold voltages and I_{LCKC} and I_{LCKD} are the charge and discharge currents.

ZXBM2001 ZXBM2002 ZXBM2003

Locked Rotor timing capacitor (CONT).

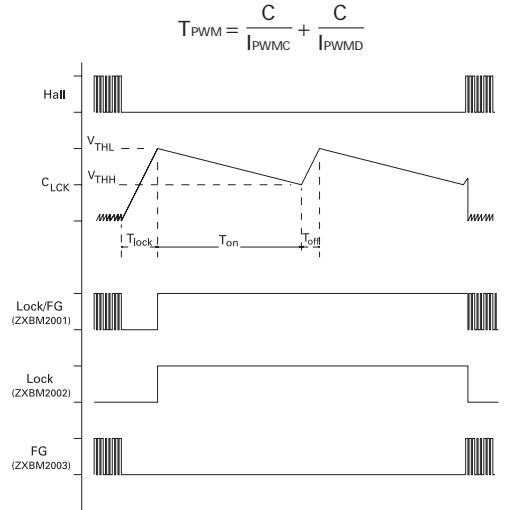

As these threshold voltages are nominally set to $V_{THH}=2V$ and $V_{THL}=1V$ the equations can be simplified as follows:

$$T_{lock} = \frac{2 \times C_{LCK}}{I_{LCKC}} \quad T_{on} = \frac{C_{LCK}}{I_{LCKC}} \quad T_{off} = \frac{C_{LCK}}{I_{LCKD}}$$

8. C_{PWM} - Sets PWM frequency
- external PWM input

This pin has an external capacitor attached to set the PWM frequency for the Phase drive outputs. A capacitor value of 0.15nF will provide a PWM frequency of typically 24kHz.

The C_{LCK} timing period (T_{pwm}) is determined by the following equation:

$$T_{lock} = \frac{(V_{THH} - V_{THL}) \times C}{I_{PWMC}} + \frac{(V_{THH} - V_{THL}) \times C}{I_{PWMD}}$$

Where T_{PWM} is in μs

$$C = C_{PWM} + 15 \text{ in pF}$$

$$I_{PWM} \text{ \& } I_{PWMD} \text{ are in } \mu A$$

Where V_{THH} and V_{THL} are the C_{PWM} pin threshold voltages and I_{PWMC} and I_{PWMD} are the charge and discharge currents.

As these threshold voltages are nominally set to $V_{THH}=2V$ and $V_{THL}=1V$ the equations can be simplified as follows:

The C_{PWM} pin can also be used as an input for an externally derived PWM signal to control the motor speed. The signal should have a $V_{OL} < 1V$ and a $V_{OH} > 2V$. A standard TTL or CMOS digital signal is ideal. When driving from an external PWM source no capacitor should be attached to the C_{PWM} pin and the SPD pin should be left open circuit.

9. PH2 - External transistor driver
10. PH1 - External transistor driver

These are the Phase drive outputs and are open darlington emitter followers designed to provide up to 80mA of drive to external transistors as shown in the Application circuits following. The external transistors in turn drive the fan motor windings.



ZXBM2001 ZXBM2002 ZXBM2003

Lock & FG Timing Waveform:

Lock Timing Example:

Using the equation previously described and to be found under the C_{LCK} pin description:

$$T_{lock} = \frac{2 \times C_{LCK}}{I_{LCKC}} \quad T_{on} = \frac{C_{LCK}}{I_{LCKC}} \quad T_{off} = \frac{C_{LCK}}{I_{LCKD}}$$

Using a value of $C_{LCK} = 1.0\mu F$ together with the values of I_{LCKC} and I_{LCKD} to be found in the Electrical Characteristics we can derive the following timings for operation at 12V and 25°C.

$$T_{lock} = \frac{2 \times 1.0\mu F}{2.8\mu A} = 0.714s \quad T_{off} = \frac{1.0\mu F}{0.28\mu A} = 3.6s$$

$$T_{on} = \frac{2 \times 1.0\mu F}{2.8\mu A} = 0.36s$$

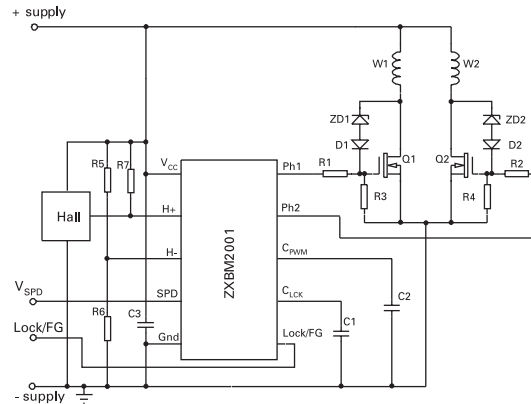

Figure 2
TYPICAL APPLICATION (ZXBM2001) using MOSFET power transistors

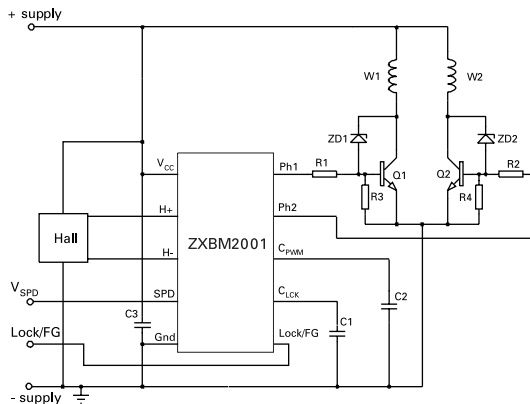
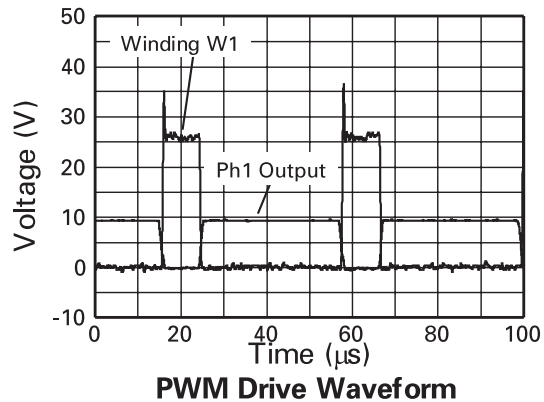

Figure 1
TYPICAL APPLICATION (ZXBM2001) using Bipolar power transistors



Graph 1

ZXBM2001 ZXBM2002 ZXBM2003

APPLICATION INFORMATION

This section gives a brief insight into applications using the ZXBM200x series. More complete data is available in the ZXBM200x Series Applications Note, visit www.zetex.com/zxbm or contact your nearest Zetex office for full details.

The ZXBM200x series of 2-phase DC brushless motor pre-drivers are capable of driving both Bipolar or MOSFET power transistors.

For smaller fans and blowers it is likely that bipolar power transistors would be used as shown in the following Applications circuit.

In Figure 1, R1 & R2 have their value selected to provide suitable base current in keeping with the winding current and gain of the power transistors Q1 & Q2. R3 & R4 have their value selected to provide efficient switch-off of Q1 & Q2. The Zener diodes ZD1 & ZD2 provide active clamping in conjunction with Q1 & Q2.

It is also recommended that the supply de-coupling capacitor C3 is positioned as close as is practical to the ZXBM device pins.

In the case of higher power fans and blowers it may be more applicable to use MOSFET devices to switch the windings as illustrated in the second applications circuit shown in Figure 2.

In Figure 2, the Resistor ratio of R1 to R3 and R2 to R4 provide the required Gate turn-on voltage whilst the absolute values will be chosen to provide sufficient gate switching currents.

Also illustrated in the two Applications circuits above are the methods of connection for both a 'naked' Hall device, as seen in the bipolar circuit in Figure 1, and a buffered Hall device, as in the MOSFET circuit in Figure 2. In this latter circuit R5 & R6 bias the H- pin at a voltage equivalent to half the swing of the Hall device. R7 will be needed if the buffered Hall device does not have its own internal pull-up.

Graph 1 below, illustrates the PWM drive waveform taken from an application using the MOSFET circuit in Figure 2. This shows the waveforms to be found at the Ph1 output and at the drain/Winding node.

ZXBM2001 ZXBM2002 ZXBM2003

When driving fans with bipolar transistors, at higher voltages it may be necessary to provide extra noise protection by the addition of a diode from the driver collector to Gnd on each phase. This prevents negative voltage excursions from the windings affecting operation. See Figure 3 right, showing the placement of these diodes. It should be noted that these are not required for the MOSFET solution in Figure 2 as the diodes are inherent in the MOSFET structure.

Zetex provide a variety of suitable power transistors for using with the ZXBM200x series of 2-phase DC brushless motor pre-drivers and suitable devices sufficient for a range of applications are given in the following table.

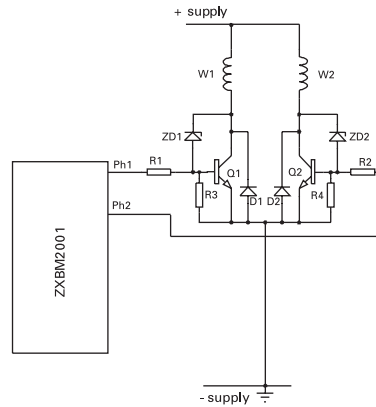

Figure 3
TYPICAL APPLICATION (ZXBM2001) illustrating addition of Clamp diodes.

SUMMARY TABLE OF SUITABLE DEVICES

Bipolar Types	V_{CEO} (V)	I_C (A)	min H_{FE} @ I_C	$V_{CE(sat)}$ max(mV) @ I_C & I_B	Package
<u>FZT1053A</u>	75	4.5	300 @ 0.5A	200 @ 1A, 10mA	SOT223
<u>EZT851</u>	60	6	100 @ 2A	100 @ 1A, 10mA	SOT223
<u>EZT853</u>	100	6	100 @ 2A	175 @ 1A, 100mA	SOT223
<u>EZT855</u>	150	4	100 @ 1A	65 @ 0.5A, 50mA	SOT223
<u>ZXT13N50DE6</u>	50	4	300 @ 1A	100 @ 1A, 10mA	SOT23-6

MOSFET Types	BV_{DSS} (V)	I_D (A)	I_{PEAK} (A) (Pulsed)	$R_{DS(on)}$ max(m Ω) @ V_{GS}	Package
<u>ZXMN3A04DN8</u> ^{2 3}	30	7.6	25	20 @ 10V	SO8
<u>ZXMN6A09DN8</u> ^{2 3}	60	5	17.6	45 @ 10V	SO8
<u>ZXMN6A11Z</u> ¹	60	3.8	10	140 @ 10V	SOT89
<u>ZXMN6A11G</u>	60	3.8	10	140 @ 10V	SOT223
<u>ZXMN10A11G</u> ^{2 4}	100	1.9	5.9	600 @ 10V	SOT223

Notes:

¹ Contact your nearest Zetex office for further details and technical enquiries.

² Dual device

³ Provisional information

⁴ Advanced information

ZXBM2001 ZXBM2002 ZXBM2003

PACKAGE OUTLINE

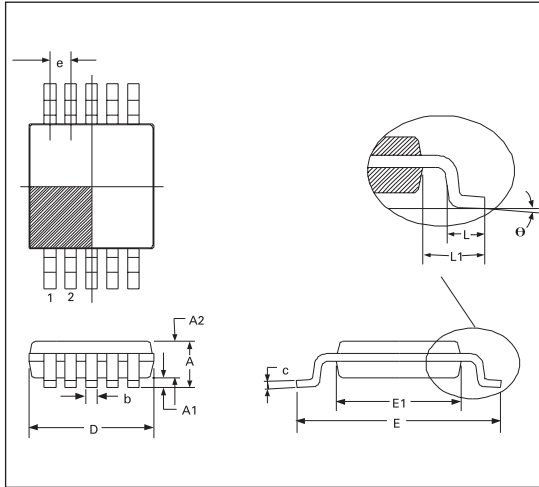

Conforms to JEDEC MO-187 VARIATION BA
CONTROLLING DIMENSIONS IN METRIC
APPROX. DIMENSION IN INCHES

PACKAGE DIMENSIONS

DIM	MILLIMETERS		INCHES	
	MIN.	MAX.	MIN.	MAX.
A	—	1.10	—	0.43
A1	—	0.15	—	0.006
A2	0.75	0.95	0.0295	0.037
D	3.00 BSC		0.118 BSC	
E	4.90 BSC		0.1929 BSC	
E1	3.00 BSC		0.118 BSC	
b	0.17	0.27	0.0066	0.0106
c	0.08	0.23	0.003	0.009
e	0.50 BSC		0.0196 BSC	
θ	0°	15°	0°	15°
L	0.40	0.80	0.015	0.031
L1	0.95 BSC		0.037 BSC	

© Zetex Semiconductors plc 2004

Europe	Americas	Asia Pacific	Corporate Headquarters
Zetex GmbH Streitfeldstraße 19 D-81673 München Germany	Zetex Inc 700 Veterans Memorial Hwy Hauppauge, NY 11788 USA	Zetex (Asia) Ltd 3701-04 Metroplaza Tower 1 Hing Fong Road, Kwai Fong Hong Kong	Zetex Semiconductors plc Lansdowne Road, Chadderton Oldham, OL9 9TY United Kingdom
Telefon: (49) 89 45 49 49 0 Fax: (49) 89 45 49 49 49 europa.sales@zetex.com	Telephone: (1) 631 360 2222 Fax: (1) 631 360 8222 usa.sales@zetex.com	Telephone: (852) 26100 611 Fax: (852) 24250 494 asia.sales@zetex.com	Telephone (44) 161 622 4444 Fax: (44) 161 622 4446 hq@zetex.com

These offices are supported by agents and distributors in major countries world-wide.

This publication is issued to provide outline information only which (unless agreed by the Company in writing) may not be used, applied or reproduced for any purpose or form part of any order or contract or be regarded as a representation relating to the products or services concerned. The Company reserves the right to alter without notice the specification, design, price or conditions of supply of any product or service.

For the latest product information, log on to www.zetex.com



ISSUE 4 - OCTOBER 2004