

INTELLIGENT HIGH SIDE MOSFET POWER SWITCH

Features

- PWM current limit for short circuit protection
- Over-temperature protection
- Active output negative clamp
- Reverse battery protection for logic circuit
- Broken ground protection
- Short to V_{CC} protection
- Low noise charge pump
- Sleep mode supply current
- 4kV ESD protection on all leads
- Logic ground isolated from power ground

General Description

The IR6210 is a 5 terminal monolithic high side switch with built in short circuit, over- temperature, ESD protections, inductive load turn off capability and diagnostic feedback.

The on-chip protection circuit goes into PWM mode, limiting the average current during short circuit if the drain current exceeds 5A. The protection circuit latches off the high side switch if the junction temperature exceeds 170°C and latches on after the junction temperature falls by 10°C. The V_{CC} (drain) to out (source) voltage is actively clamped at 55V, improving its performance during turn off with inductive loads.

The on-chip charge pump high side driver stage is floating and referenced to the source of the Power MOSFET. Thus the logic to power ground isolation can be as high as 50V. This allows operation with larger offset as well as controlling the switch during load energy recirculation or regeneration.

A diagnostic pin is provided for status feedback of short circuit, over temperature and open load detection.

Product summary

V _{CC(op)}	5-50V
R _{DS(on)}	200mΩ
I _{lim}	5A
T _{j(sd)}	170°C
E _{av}	100mJ

Applications

- Solenoid driver
- Programmable logic controller

Truth Table

Condition	In	Out	Dg
Normal	H	H	H
Normal	L	L	L
Output Open	H	H	H
Output Open	L	H	H
Shorted Output	H	Current-Limiting PWM Mode	L
Shorted Output	L	L	L
Over-Temperature	H	L	L
Over-Temperature	L	L	L

Block Diagram

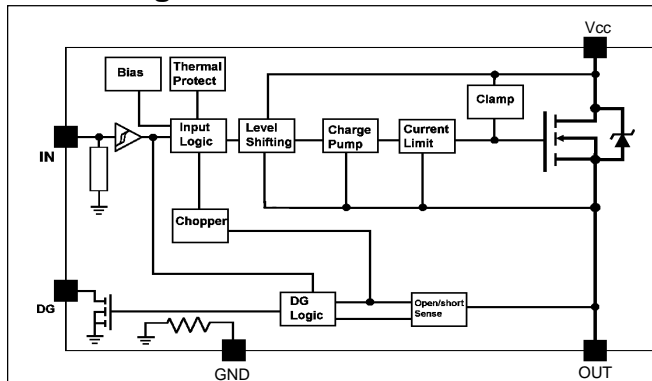

Packages

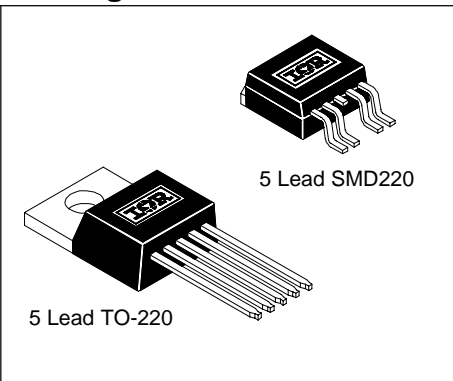

Absolute Maximum Ratings

Absolute maximum ratings indicate sustained limits beyond which damage to the device may occur.
($T_C = 25^\circ\text{C}$ unless otherwise specified.)

Symbol	Parameter	Min.	Max.	Units	Test Conditions
V _{cc}	Supply voltage permanent	-0.3	50	V	For 10 seconds, (1)
	reverse	-16	—		
V _{offset}	Logic to power ground offset	V _{cc} -50	V _{cc} +0.3		
V _{in}	Input voltage	-0.3	30		
I _{in}	Input current	—	10	mA	
V _{out}	Output voltage	V _{cc} -50	V _{cc} +0.3	V	
I _{out}	Output current	—	self-limited	A	
V _{dg}	Diagnostic output voltage	-0.3	30	V	
I _{dg}	Diagnostic output current	—	10	mA	
E _{av}	Repetitive avalanche energy	—	100	mJ	I = 2A (2)
ESD1	Electrostatic discharge (Human Body Model)	—	4000	V	C = 100 pF, R = 1500Ω
ESD2	Electrostatic discharge (Machine Model)	—	1000	V	C = 200 pF, R = 0Ω
PD	Power dissipation	—	28	W	T _{case} = 25°C
T _{Jop}	Operating junction temperature range	-40	150	°C	
T _{Stg}	Storage temperature range	-40	150		
T _L	Lead temperature (soldering, 10 seconds)	—	300		

NOTES: (1) with 15kΩ resistors in input and diagnostic

(2) maximum frequency depends on heatsink (rectangular waveform)

Static Electrical Characteristics

($T_C = 25^\circ\text{C}$ unless otherwise specified.)

Symbol	Parameter	Min.	Typ.	Max.	Units	Test Conditions
V _{ccop}	Operating voltage range	5	—	35	V	
I _{ccoff}	Sleep mode supply current	—	40	—	μA	V _{cc} =24V, V _{in} = 0V
I _{ccon}	Supply current (average)	—	3	—	mA	V _{in} = 5V
I _{ccac}	Supply current (AC RMS)	—	20	—	μA	V _{in} = 5V
V _{ih}	High level input threshold voltage	—	2	2.5	V	
V _{il}	Low level input threshold voltage	1	1.8	—		
I _{ion}	On-state input current	10	—	70	μA	V _{in} = 3.5V
I _{loff}	Off-state input current	1	—	30		V _{in} = 0.4V
I _{oh}	Output leakage current	—	20	—		V _{out} = 6V
I _{ol}	Output leakage current	0	—	10		V _{out} = 0V
V _{dgl}	Low level diagnostic output voltage	—	0.3	—	V	I _{dg} = 1.6mA
I _{dgh}	Diagnostic output leakage current	0	—	10	μA	V _{dg} = 5V
R _{DS(on)}	On-state resistance	—	150	200	mΩ	I _{out} = 1A
		—	200	—		V _{cc} = 5V, I _{out} = 1A

Switching Electrical Characteristics

($V_{CC} = 14V$, resistive load ($R_L = 12\Omega$, $T_C = 25^\circ C$.)

Symbol	Parameter	Min.	Typ.	Max.	Units	Test Conditions
t_c	Over-current cycle time	—	5	—	ms	
D_c	Over-current duty cycle	—	10	—	%	
t_{on}	Turn-on delay time to 90%	—	50	—	μs	
t_{off}	Turn-off delay time to 10%	—	60	—		
dv/dt_{on}	Slew rate on	—	3	—	V/μs	
dv/dt_{off}	Slew rate off	—	5	—		

Protection Characteristics

Symbol	Parameter	Min.	Typ.	Max.	Units	Test Conditions
I_{lim}	Internal current limit	—	5	—	A	
V_{sc}	Short circuit detection voltage	—	3.5	—	V	
V_{slh}	Open load detection voltage	—	3.5	—		
V_{cl1}	Output negative clamp	50	54	—		$I_{out} = 10mA$
V_{cl2}	Output negative clamp	—	56	62		$I_{out} = 2A$

Thermal Characteristics

Symbol	Parameter	Min.	Typ.	Max.	Units	Test Conditions
T_{jSD}	Thermal shutdown temperature	—	170	—	°C	
T_{hys}	Thermal hysteresis	—	10	—		
R_{thjc}	Thermal resistance, junction to case	—	3.5	—	°C/W	
R_{thja}	Thermal resistance, junction to ambient	—	50	—		

Lead Assignments

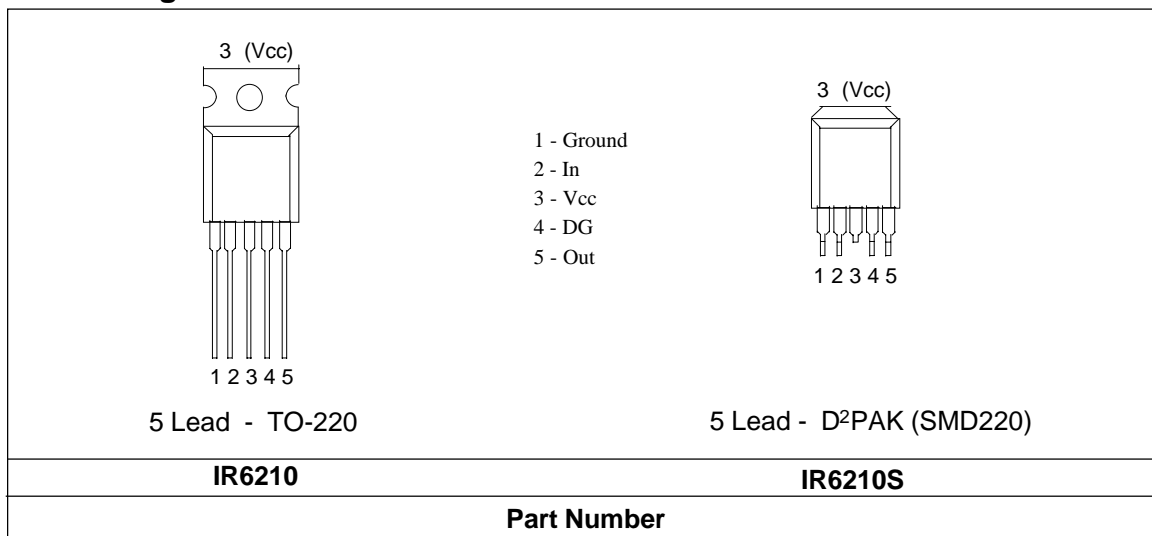

IR6210

International
IR Rectifier

Case Outline 5 Lead - TO-220

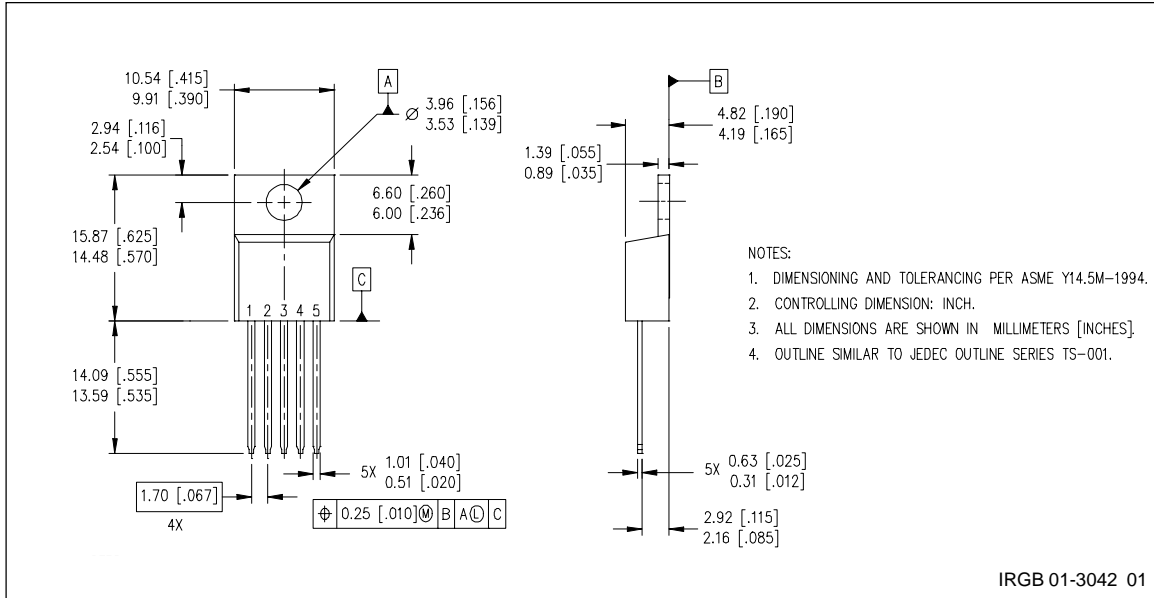

Tape & Reel 5 Lead - D²PAK (SMD220)

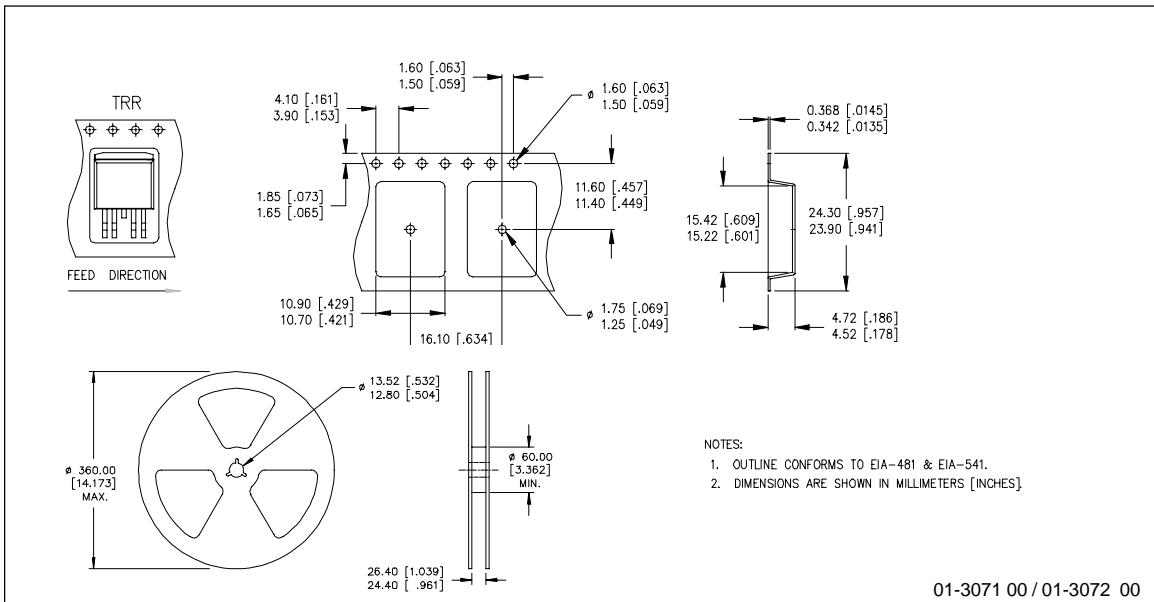

Case Outline 5 Lead - SMD220 (D²PAK)

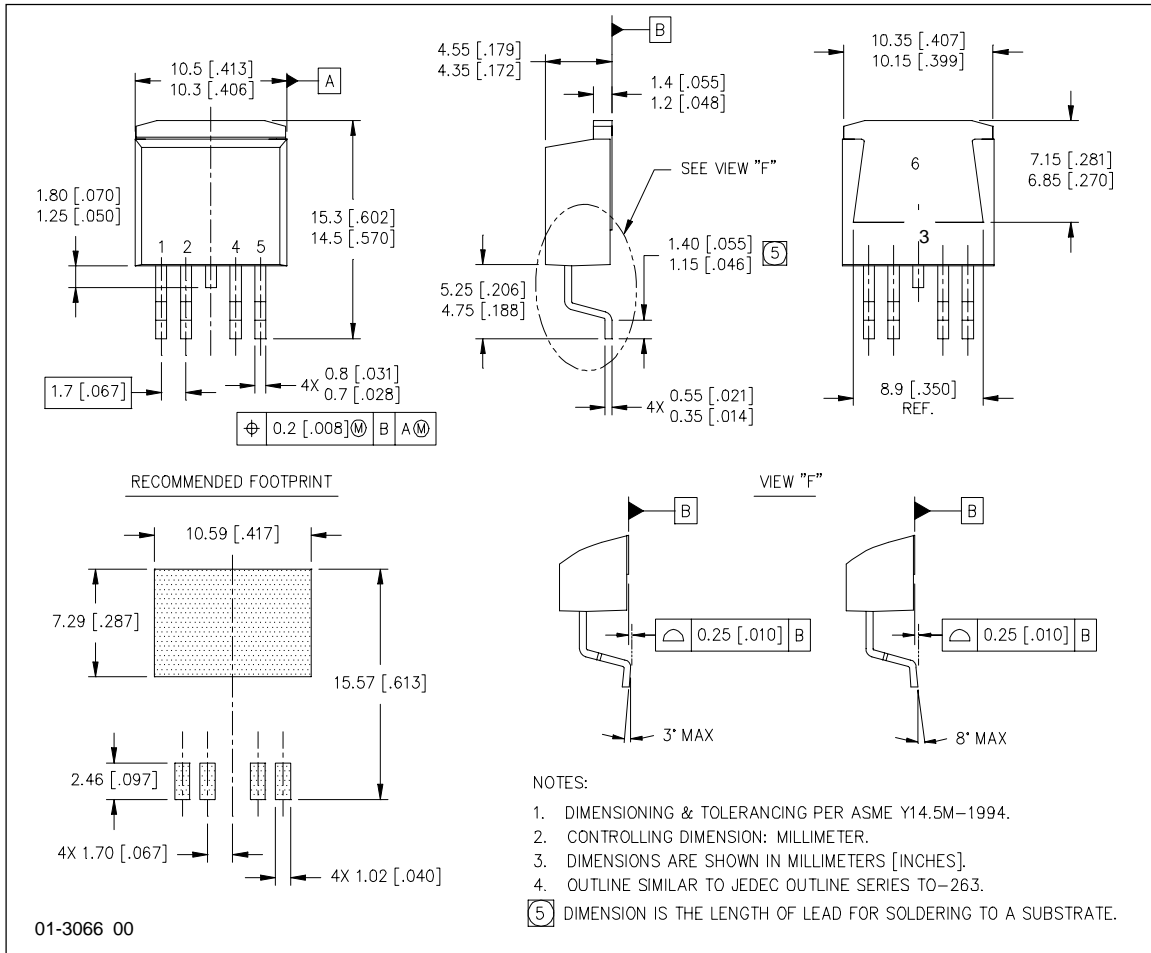

Note: For the most current drawings please refer to the IR website at:
<http://www.irf.com/package/>