

# IPS511G/IPS512G

## FULLY PROTECTED HIGH SIDE POWER MOSFET SWITCH

### Features

- Over temperature protection (with auto-restart)
- Short-circuit protection (current limit)
- Active clamp
- E.S.D protection
- Status feedback
- Open load detection
- Logic ground isolated from power ground

### Description

The IPS511G/IPS512G are fully protected five terminal high side switches with built in short-circuit, over-temperature, ESD protection, inductive load capability and diagnostic feedback. The output current is controlled when it reaches  $I_{lim}$  value. The current limitation is activated until the thermal protection acts. The over-temperature protection turns off the high side switch if the junction temperature exceeds  $T_{shutdown}$ . It will automatically restart after the junction has cooled  $7^{\circ}\text{C}$  below  $T_{shutdown}$ . A diagnostic pin is provided for status feedback of short-circuit, over-temperature and open load detection. The double level shifter circuitry allows large offsets between the logic ground and the load ground.

### Product Summary

$R_{ds(on)}$	150m $\Omega$ (max)
$V_{clamp}$	50V
I Limit	5A
$V_{open\ load}$	3V

### Truth Table

Op. Conditions	In	Out	Dg
Normal	H	H	H
Normal	L	L	L
Open load	H	H	H
Open load	L	H	H
Over current	H	L (limiting)	L
Over current	L	L	L
Over-temperature	H	L (cycling)	L
Over-temperature	L	L	L

### Typical Connection

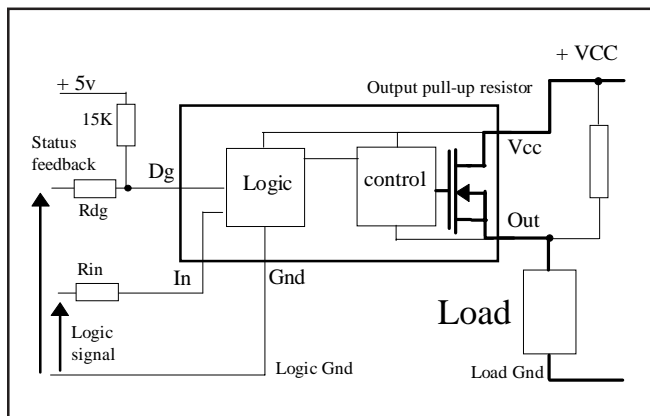

### Available Package

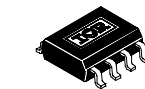

8 Lead SOIC  
 (Single)  
 IPS511G

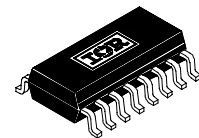

16 Lead SOIC  
 (Dual)  
 IPS512G

## Absolute Maximum Ratings

Absolute maximum ratings indicate sustained limits beyond which damage to the device may occur. All voltage parameters are referenced to GROUND lead. ( $T_j = 25^\circ\text{C}$  unless otherwise specified).

Symbol	Parameter	Min.	Max.	Units	Test Conditions
$V_{out}$	Maximum output voltage	$V_{CC}-50$	$V_{CC}+0.3$	V	
$V_{offset}$	Maximum logic ground to load ground offset	$V_{CC}-50$	$V_{CC}+0.3$		
$V_{in}$	Maximum Input voltage	-0.3	5.5		
$I_{in, max}$	Maximum IN current	-5	10	mA	
$V_{dg}$	Maximum diagnostic output voltage	-0.3	5.5	V	
$I_{dg, max}$	Maximum diagnostic output current	-1	10	mA	
$I_{sd cont.}$	Diode max. continuous current <sup>(1)</sup>  (IPS511G) (per leg/both legs ON - IPS512G)	—	1.4	A	
		—	0.8		
$I_{sd pulsed}$	Diode max. pulsed current <sup>(1)</sup>	—	10		
ESD1	Electrostatic discharge voltage (Human Body)	—	4000	V	C=100pF, R=1500Ω,
ESD2	Electrostatic discharge voltage (Machine Model)	—	500		C=200pF, R=0Ω, L=10μH
$P_d$	Maximum power dissipation ( $r_{th}=125^\circ\text{C/W}$ ) IPS511G	—	1	W	
	( $r_{th}=85^\circ\text{C/W}$ , both legs on) IPS512G	—	1.5		
$T_j max.$	Max. storage & operating junction temp.	-40	+150	$^\circ\text{C}$	
$V_{vv max}$	Maximum Vcc voltage	—	50	V	

## Thermal Characteristics

Symbol	Parameter	Min.	Typ.	Max.	Units	Test Conditions
$R_{th1}$	Thermal resistance with standard footprint	—	100	—	$^\circ\text{C/W}$	8 Lead SOIC
$R_{th2}$	Thermal resistance with 1" square footprint	—	80	—		
$R_{th1}$ (2 mos on)	Thermal resistance with standard footprint (2 mosfets on)	—	85	—		16 Lead SOIC
$R_{th2}$ (1) (1 mos on)	Thermal resistance with standard footprint (1 mosfet on)	—	100	—		
$R_{th2}$ (2 mos on)	Thermal resistance with 1" square footprint (2 mosfets on)	—	50	—		

(1) Limited by junction temperature (pulsed current limited also by internal wiring)

### Recommended Operating Conditions

These values are given for a quick design. For operation outside these conditions, please consult the application notes.

Symbol	Parameter	Min.	Max.	Units
V <sub>CC</sub>	Continuous V <sub>CC</sub> voltage	5.5	35	V
V <sub>IH</sub>	High level input voltage	4	5.5	
V <sub>IL</sub>	Low level input voltage	-0.3	0.9	
I <sub>out</sub> T <sub>amb</sub> =85°C	Continuous output current (T <sub>Ambient</sub> = 85°C, T <sub>j</sub> = 125°C, r <sub>th</sub> = 100°C/W) IPS511G	—	1.4	A
I <sub>out</sub> T <sub>amb</sub> =85°C	Continuous output current per leg (T <sub>Ambient</sub> = 85°C, T <sub>j</sub> = 125°C R <sub>th</sub> = 85°C/W both legs on) IPS512G	—	1.0	
R <sub>in</sub>	Recommended resistor in series with IN pin	4	6	kΩ
R <sub>dg</sub>	Recommended resistor in series with DG pin	10	20	

### Static Electrical Characteristics

(T<sub>j</sub> = 25°C, V<sub>CC</sub> = 14V unless otherwise specified.)

Symbol	Parameter	Min.	Typ.	Max.	Units	Test Conditions
R <sub>ds(on)</sub> @T <sub>j</sub> =25°C	ON state resistance T <sub>j</sub> = 25°C	—	130	150	mΩ	V <sub>in</sub> = 5V, I <sub>out</sub> = 2.5A
R <sub>ds(on)</sub> (V <sub>CC</sub> =6V)	ON state resistance @ V <sub>CC</sub> = 6V	—	130	150		V <sub>in</sub> = 5V, I <sub>out</sub> = 1A
R <sub>ds(on)</sub> @T <sub>j</sub> =150°C	ON state resistance T <sub>j</sub> = 150°C	—	220	—		V <sub>in</sub> = 5V, I <sub>out</sub> = 2.5A
V <sub>CC oper.</sub>	Operating voltage range	5.5	—	35	V	
V <sub>clamp 1</sub>	V <sub>CC</sub> to OUT clamp voltage 1	50	56	—		I <sub>d</sub> = 10mA (see Fig.1 & 2)
V <sub>clamp 2</sub>	V <sub>CC</sub> to OUT clamp voltage 2	—	58	65		I <sub>d</sub> = I <sub>sd</sub> (see Fig.1 & 2)
V <sub>f</sub>	Body diode forward voltage	—	0.9	1.2		I <sub>d</sub> = 2.5A, V <sub>in</sub> = 0V
I <sub>CC off</sub>	Supply current when OFF	—	16	50	μA	V <sub>in</sub> = 0V, V <sub>out</sub> = 0V
I <sub>CC on</sub>	Supply current when ON	—	0.7	2	mA	V <sub>in</sub> = 5V
I <sub>CC ac</sub>	Ripple current when ON (AC RMS)	—	20	—	μA	V <sub>in</sub> = 5V
V <sub>dg1</sub>	Low level diagnostic output voltage	—	0.15	0.4	V	I <sub>dg</sub> = 1.6 mA
I <sub>ol</sub>	Output leakage current	—	60	120	μA	V <sub>out</sub> = 6V
I <sub>ol</sub>	Output leakage current	0	—	25		V <sub>out</sub> = 0V
I <sub>dg leakage</sub>	Diagnostic output leakage current	—	—	10		V <sub>dg</sub> = 5.5V
V <sub>Ih</sub>	IN high threshold voltage	—	2.3	2.5	V	
V <sub>Il</sub>	IN low threshold voltage	1	2	—		
I <sub>in, on</sub>	On state IN positive current	—	70	200	μA	V <sub>in</sub> = 5V
I <sub>n, hyst.</sub>	Input hysteresis	0.1	0.25	0.5	V	

# IPS511G/IPS512G

## Switching Electrical Characteristics

V<sub>CC</sub> = 14V, Resistive Load = 5.6Ω, T<sub>j</sub> = 25°C, (unless otherwise specified).

Symbol	Parameter	Min.	Typ.	Max.	Units	Test Conditions
T <sub>don</sub>	Turn-on delay time	—	7	50	μs	See figure 3
T <sub>r1</sub>	Rise time to V <sub>out</sub> = V <sub>CC</sub> - 5V	—	10	50		
T <sub>r2</sub>	Rise time from the end of TR1 to V <sub>out</sub> = 90% of V <sub>CC</sub>	—	45	95		
dV/dt (on)	Turn ON dV/dt	—	1.3	4	V/μs	
E <sub>on</sub>	Turn ON energy	—	400	—	μs	See figure 4
T <sub>doff</sub>	Turn-off delay time	—	15	50		
T <sub>f</sub>	Fall time to V <sub>out</sub> = 10% of V <sub>CC</sub>	—	10	50		
dV/dt (off)	Turn OFF dV/dt	—	2	6	V/μs	
E <sub>off</sub>	Turn OFF energy	—	80	—	μJ	
T <sub>diag</sub>	V <sub>out</sub> to V <sub>diag</sub> propagation delay	—	5	15	μs	

## Protection Characteristics

Symbol	Parameter	Min.	Typ.	Max.	Units	Test Conditions
I <sub>lim</sub>	Internal current limit	3	5	7	A	V <sub>out</sub> = 0V
T <sub>sd+</sub>	Over-temp. positive going threshold	—	165	—	°C	See fig. 2
T <sub>sd-</sub>	Over-temp. negative going threshold	—	158	—	°C	See fig. 2
V <sub>sc</sub>	Short-circuit detection voltage (3)	2	3	4	V	See fig. 2
V <sub>open load</sub>	Open load detection threshold	2	3	4	V	

(3) Referenced to V<sub>CC</sub>

## Lead Assignments

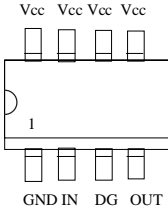
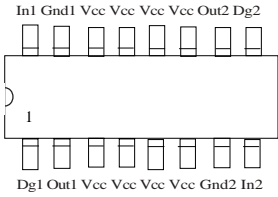
 <p>8 Lead SOIC</p>	 <p>16 Lead SOIC</p>
<b>IPS511G</b>	<b>IPS512G</b>
<b>Part Number</b>	

Functional Block Diagram

All values are typical

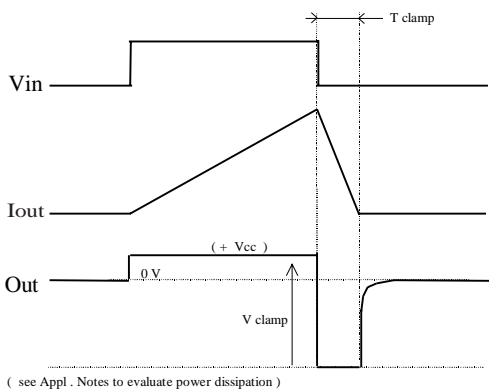
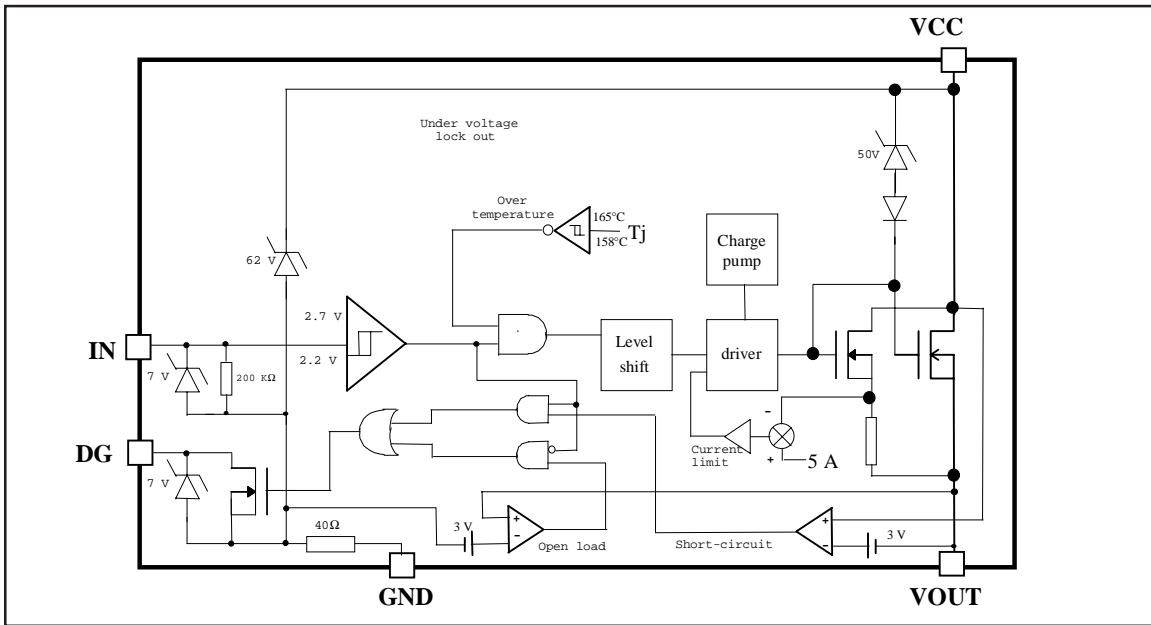

Figure 1 - Active clamp waveforms

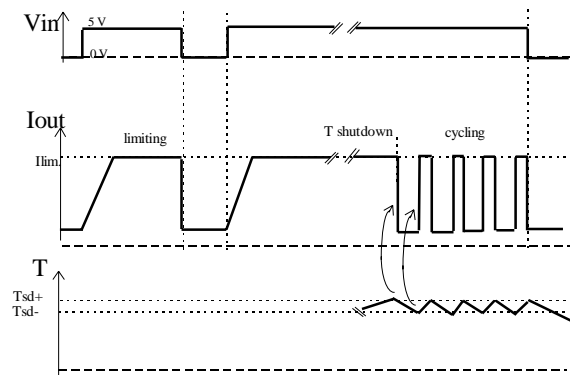

Figure 2 - Protection timing diagram

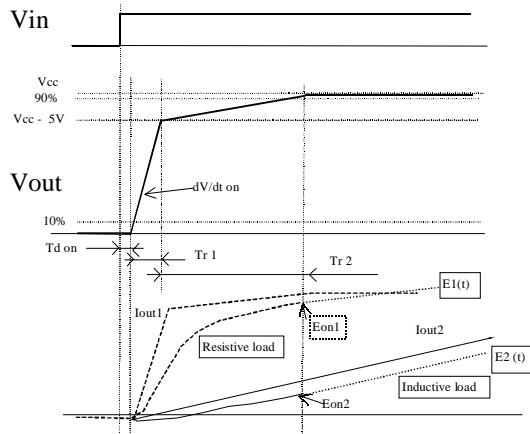

Figure 3 - Switching times definition (turn-on)  
Turn on energy with a resistive or an inductive load

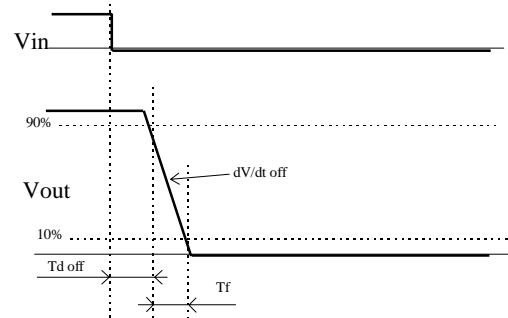

Figure 4 - Switching times definition (turn-off)

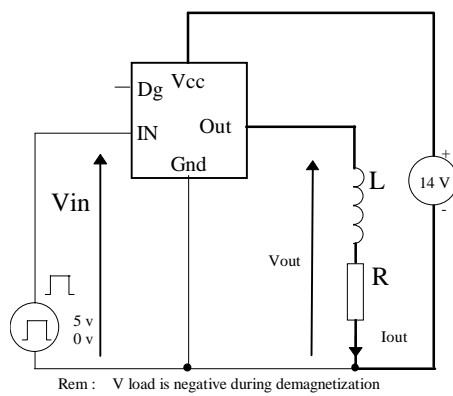

Figure 5 - Active clamp test circuit

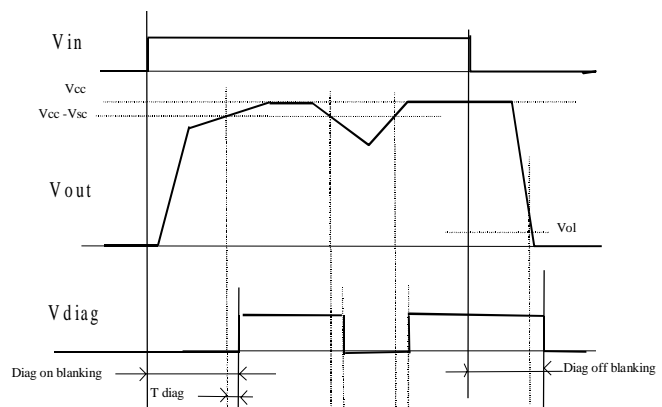

Figure 6 - Diagnostic delay definitions

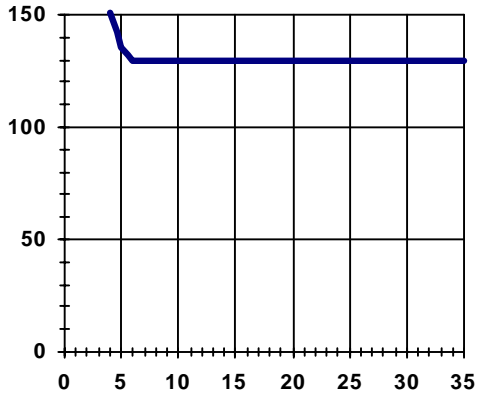

Figure 7 - R<sub>ds(on)</sub> (mΩ) Vs V<sub>CC</sub> (V)

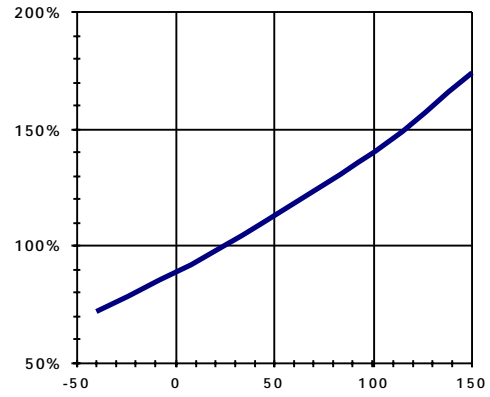

Figure 8 - Normalized R<sub>ds(on)</sub> Vs T<sub>j</sub> (°C)

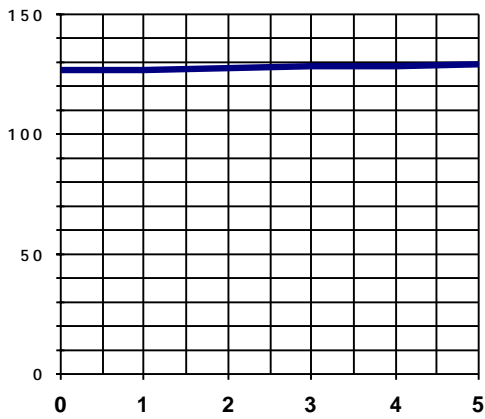

Figure 9 - R<sub>ds(on)</sub> (mΩ) Vs I<sub>out</sub> (A)

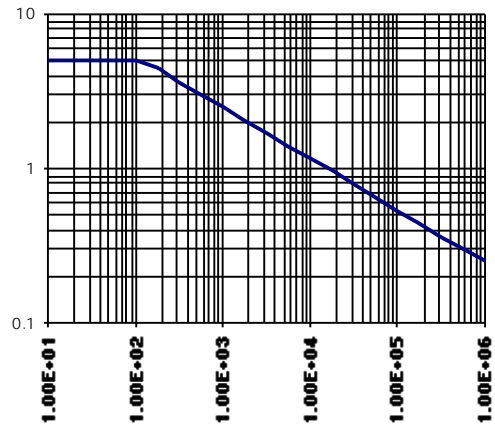

Figure 10 - Max. I<sub>out</sub> (A) Vs Load Inductance (uH)

# IPS511G/IPS512G

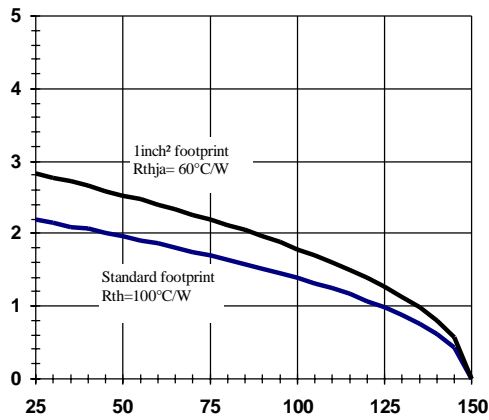

Figure 11a - Max load current (A) Vs Tamb (°C)  
IPS511G

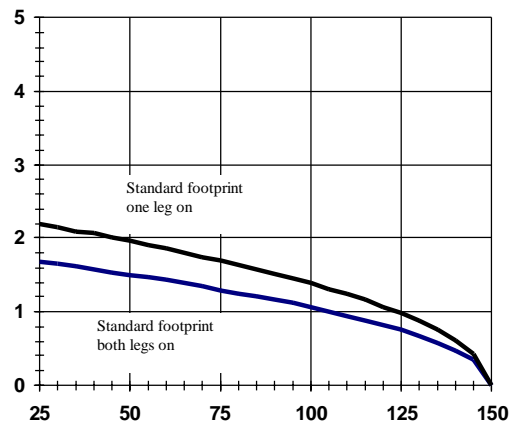

Figure 11b - Max load current (A) Vs Tamb (°C)  
IPS512G

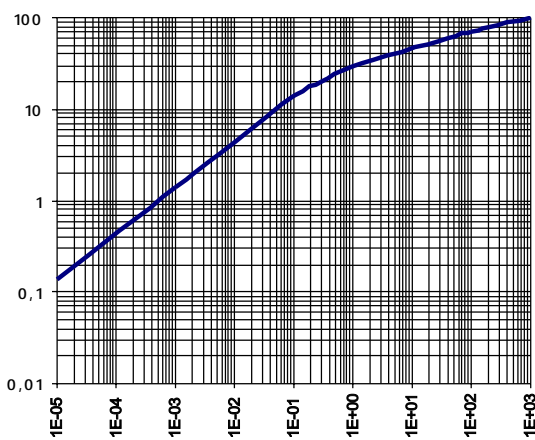

Figure 12 - Transient Thermal Impedance (°C/W)  
Vs Time (S) - IPS511G/IPS512G

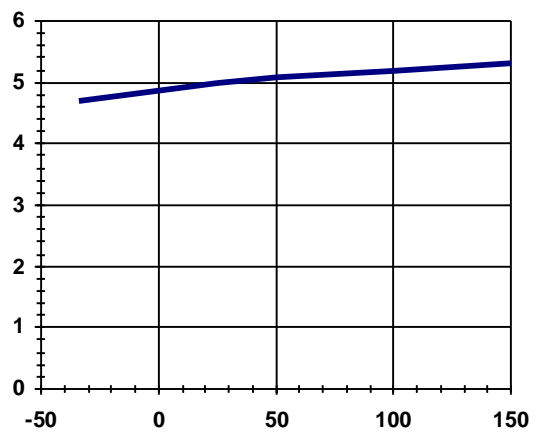

Figure 13 - Ilim (A) Vs Tj (°C)



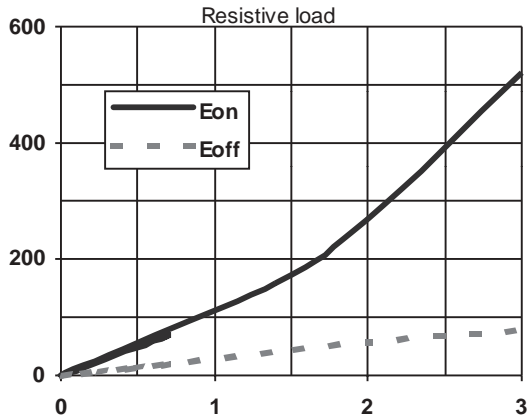

Figure 14 -  $E_{on}$ ,  $E_{off}$  ( $\mu$ J) vs I (A)

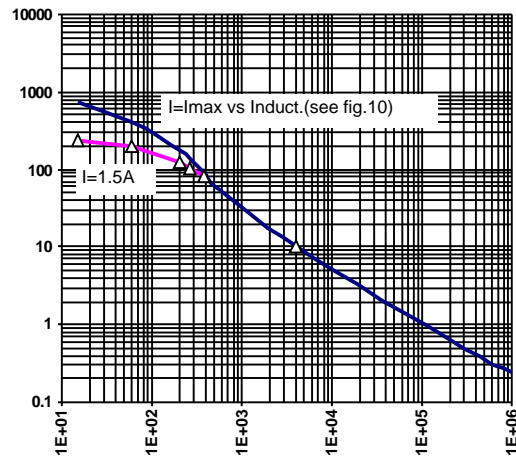

Figure 15 -  $E_{on}$  ( $\mu$ J) Vs Load Inductance ( $\mu$ H)  
(see Fig. 3)

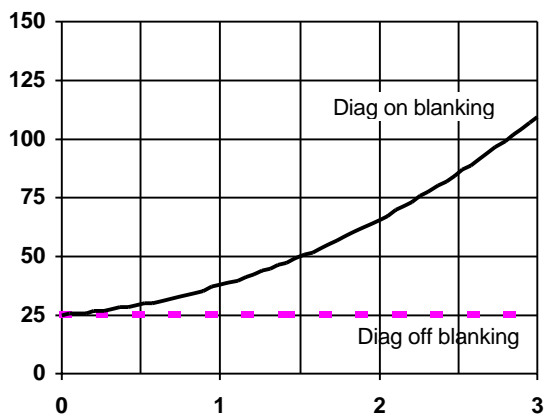

Figure 16 - Diag Blanking time ( $\mu$ S) Vs  $I_{out}$  (A)  
(resistive load - see Fig. 6)

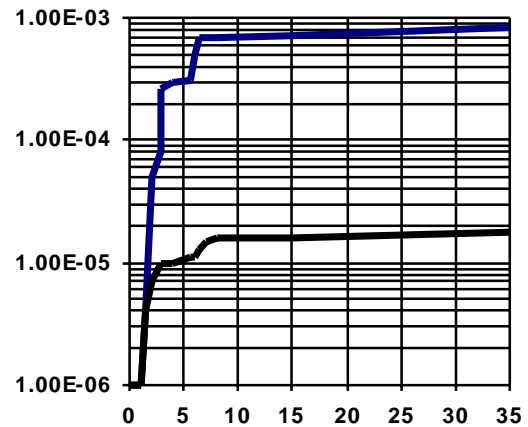
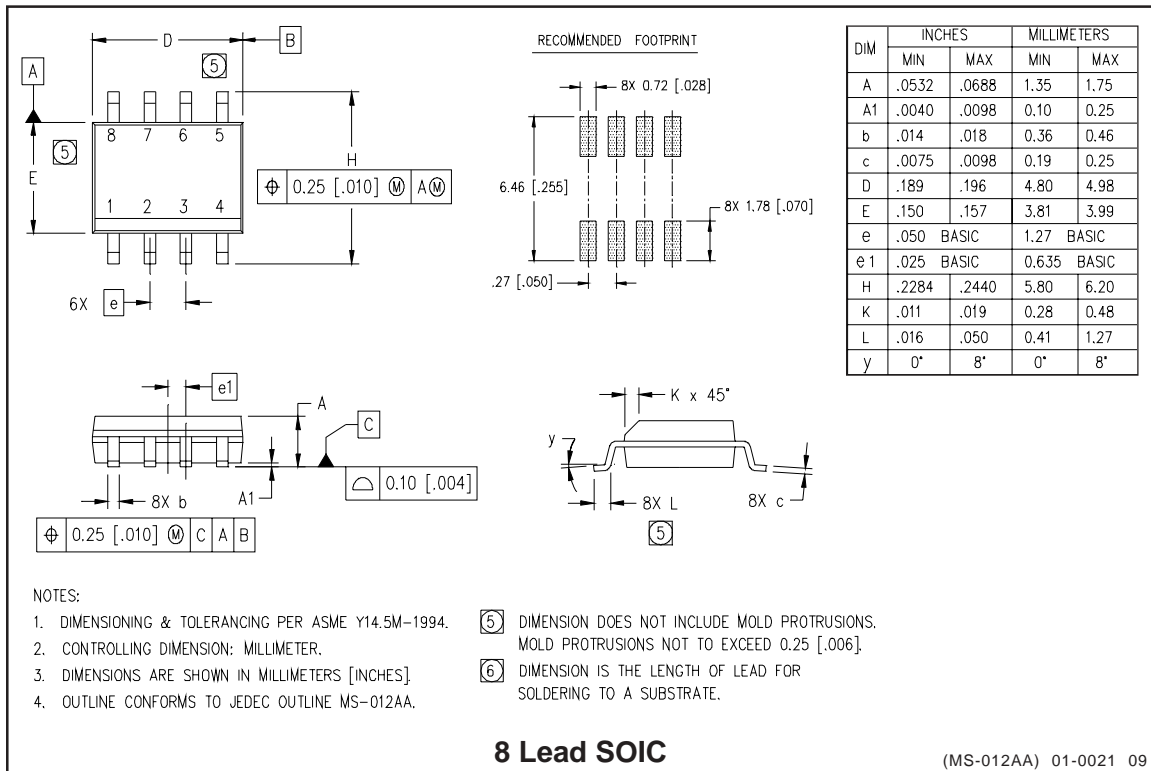

Figure 17 -  $I_{cc}$  (mA) Vs  $V_{cc}$  (V)

# IPS511G/IPS512G

International  
**IR** Rectifier

## Case Outline - IPS511G



**Case Outline**

