

ISOFACE™

ISO1H815G

Coreless Transformer Isolated
Digital Output 8 Channel 1.2A
High-Side Switch

Power Management & Drives



Never stop thinking.

ISO1H815G**Revision History: 2009-07-28**Version 2.0

Previous Version: V1.0

V2.0 Final Datasheet

Edition 2009-07-28**Published by Infineon Technologies AG,
Am Campeon 1-12,
85579 Neubiberg, Germany****© Infineon Technologies AG 2009.
All Rights Reserved.****Attention please!**

The information herein is given to describe certain components and shall not be considered as a guarantee of characteristics.

Terms of delivery and rights to technical change reserved.

We hereby disclaim any and all warranties, including but not limited to warranties of non-infringement, regarding circuits, descriptions and charts stated herein.

Information

For further information on technology, delivery terms and conditions and prices please contact your nearest Infineon Technologies Office (www.infineon.com).

Warnings

Due to technical requirements components may contain dangerous substances. For information on the types in question please contact your nearest Infineon Technologies Office.

Infineon Technologies Components may only be used in life-support devices or systems with the express written approval of Infineon Technologies, if a failure of such components can reasonably be expected to cause the failure of that life-support device or system, or to affect the safety or effectiveness of that device or system. Life support devices or systems are intended to be implanted in the human body, or to support and/or maintain and sustain and/or protect human life. If they fail, it is reasonable to assume that the health of the user or other persons may be endangered.

Coreless Transformer Isolated Digital Output 8 Channel 1.2A High-Side Switch

Product Highlights

- Coreless transformer isolated data interface
- Galvanic isolation
- 8 High-side output switches 1,2A
- μ C compatible 8-bit parallel peripheral
- Isolated return path for DIAG signal



Features

- Interface 3.3/5V CMOS operation compatible
- Parallel interface
- Direct control mode
- High common mode transient immunity
- Short circuit protection
- Maximum current internally limited
- Overload protection
- Overvoltage protection (including load dump)
- Undervoltage shutdown with autorestart and hysteresis
- Switching inductive loads
- Common output disable pin
- Thermal shutdown with restart
- Thermal independence of separate channels
- Common diagnostic output for overtemperature
- ESD protection
- Loss of GND_{bb} and loss of V_{bb} protection
- Reverse Output Voltage protection
- RoHS compliant

Typical Application

- Isolated switch for industrial applications (PLC)
- All types of resistive, inductive and capacitive loads
- μ C compatible power switch for 24V DC applications
- Driver for solenoid, relays and resistive loads

Description

The ISO1H815G is a galvanically isolated 8 bit data interface in PG-DSO-36 package that provides 8 fully protected high-side power switches that are able to handle currents up to 1.2A.

An 8 bit parallel μ C compatible interface allows to connect the IC directly to a μ C system. The input interface supports also a direct control mode and is designed to operate with 3.3/5V CMOS compatible levels.

The data transfer from input to output side is realized by the integrated Coreless Transformer Technology.

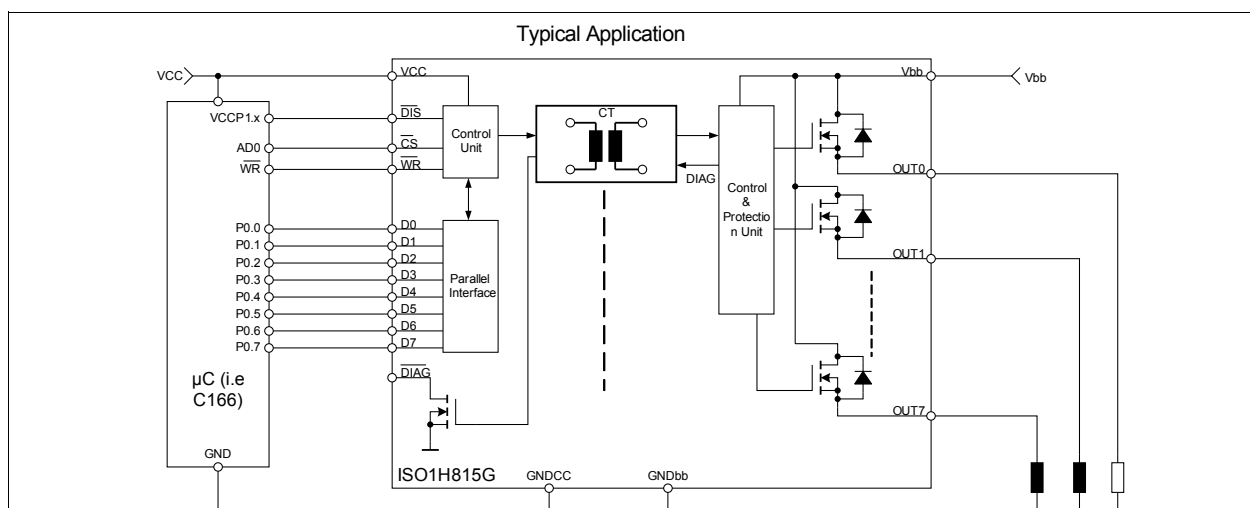

Type	On-state Resistance	Package
ISO1H815G	200m Ω	PG-DSO-36

1 Pin Configuration and Functionality

1.1 Pin Configuration

Pin	Symbol	Function
1	N.C.	Not connected
2	VCC	Positive 3.3/5V logic supply
3	$\overline{\text{DIS}}$	Output disable
4	$\overline{\text{CS}}$	Chip select
5	$\overline{\text{WR}}$	Parallel write
6	D0	Data input bit0
7	D1	Data input bit1
8	D2	Data input bit2
9	D3	Data input bit3
10	D4	Data input bit4
11	D5	Data input bit5
12	D6	Data input bit6
13	D7	Data input bit7
14	$\overline{\text{DIAG}}$	Common diagnostic output for overtemperature
15	GNDCC	Input logic ground
16	N.C.	Not connected
17	N.C.	Not connected
18	N.C.	Not connected
19	GNDbb	Output driver ground
20	N.C.	Not connected
21	OUT7	High-side output of channel 7
22	OUT7	High-side output of channel 7
23	OUT6	High-side output of channel 6
24	OUT6	High-side output of channel 6
25	OUT5	High-side output of channel 5
26	OUT5	High-side output of channel 5
27	OUT4	High-side output of channel 4
28	OUT4	High-side output of channel 4
29	OUT3	High-side output of channel 3
30	OUT3	High-side output of channel 3
31	OUT2	High-side output of channel 2
32	OUT2	High-side output of channel 2
33	OUT1	High-side output of channel 1
34	OUT1	High-side output of channel 1
35	OUT0	High-side output of channel 0
36	OUT0	High-side output of channel 0
TAB	Vbb	Positive driver power supply voltage

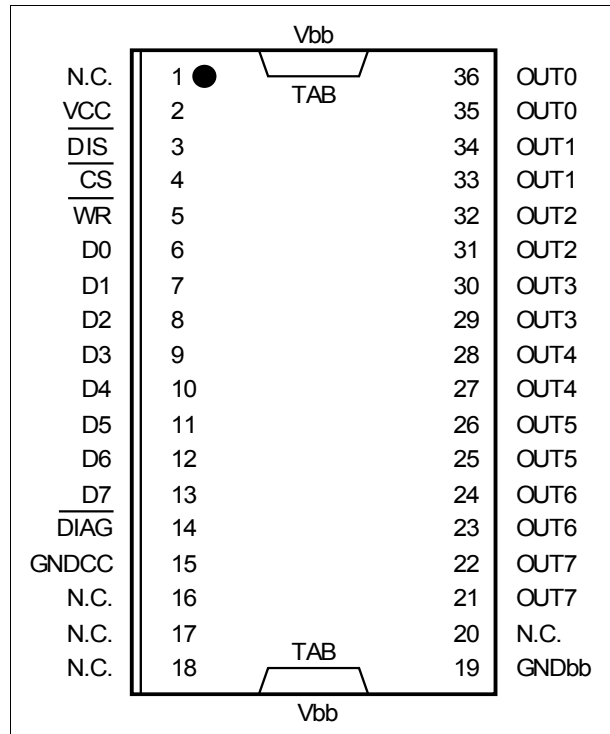

Figure 1 Power SO-36 (430mil)

1.2 Pin Functionality

VCC (Positive 3.3/5V logic supply)

The VCC supplies the input interface that is galvanically isolated from the output driver stage. The input interface can be supplied with 3.3/5V.

$\overline{\text{DIS}}$ (Output disable)

The high-side outputs OUT0...OUT7 can be immediately switched off by means of the low active pin $\overline{\text{DIS}}$ that is an asynchronous signal. The input registers are also reset by the $\overline{\text{DIS}}$ signal. The Output remains switched off after low-high transition of $\overline{\text{DIS}}$ signal, till new information is written into the input register. Current Sink to GNDCC.

$\overline{\text{CS}}$ (Chip select)

The system microcontroller selects the ISO1H815G by means of the low active pin $\overline{\text{CS}}$ to activate the parallel interface. By connecting the $\overline{\text{CS}}$ pin and $\overline{\text{WR}}$ pin to ground the parallel direct control is activated. Current Source to VCC.

$\overline{\text{WR}}$ (Parallel write)

In parallel mode data at the input pins (D0 ... D7) are latched by means of the rising edge of the low active signal $\overline{\text{WR}}$ (write). Current Source to VCC.

D0 ... D7 (Data input bit0 ... bit7)

The present data can be latched on the rising edge of the write signal $\overline{\text{WR}}$. D0 ... D7 control the corresponding output channels OUT0 ...OUT7. By connecting CS and $\overline{\text{WR}}$ to ground, the signals at D0 ... D7 directly control the outputs. Current Sink to GNDCC.

$\overline{\text{DIAG}}$ (Common diagnostic output for overtemperature)

The low active $\overline{\text{DIAG}}$ signal contains the OR-wired information of the separated overtemperature detection units for each channel. The output pin $\overline{\text{DIAG}}$ provides an open drain functionality. A current source is also connected to the pin $\overline{\text{DIAG}}$. In normal operation the signal $\overline{\text{DIAG}}$ is high. When overtemperature or Vbb below ON-Limit is detected the signal $\overline{\text{DIAG}}$ changes to low.

GNDCC (Ground for VCC domain)

This pin acts as the ground reference for the input interface that is supplied by VCC.

GNDbb (Output driver ground domain)

This pin acts as the ground reference for the output

driver that is supplied by Vbb.

OUT0 ... OUT7 (High side output channel 0 ... 7)

The output high side channels are internally connected to Vbb and controlled by the corresponding data input pins D0 ... D7 in parallel mode.

TAB (Vbb, Positive supply for output driver)

The heatslug is connected to the positive supply port of the output interface.

2 Blockdiagram

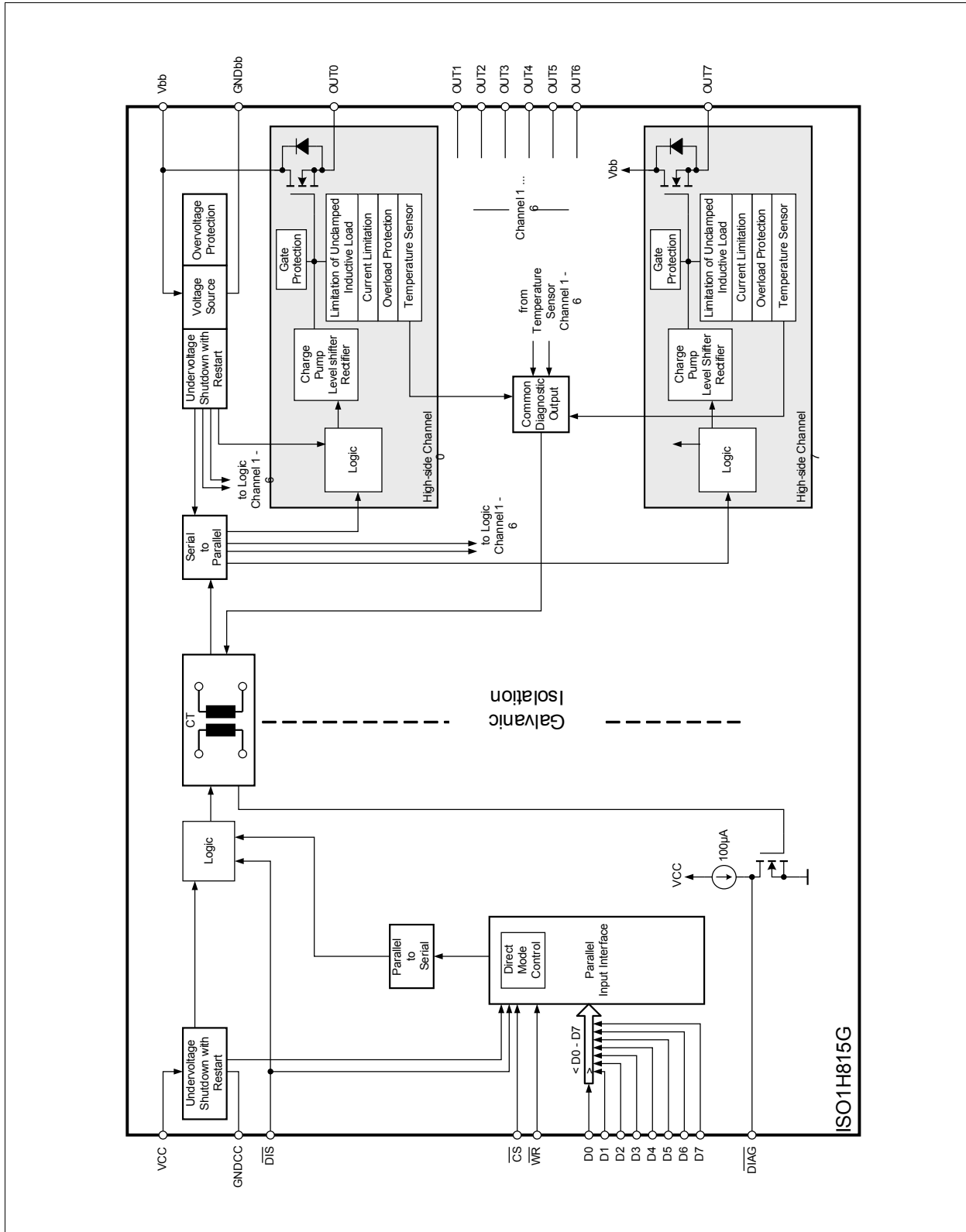

Figure 2 Blockdiagram

3 Functional Description

3.1 Introduction

The ISOFACE ISO1H815G includes 8 high-side power switches that are controlled by means of the integrated parallel interface. The interface is 8bit μC compatible. Furthermore a direct control mode can be selected that allows the direct control of the outputs OUT0...OUT7 by means of the inputs D0...D7 without any additional logic signal. The IC can replace 8 optocouplers and the 8 high-side switches in conventional I/O-Applications as a galvanic isolation is implemented by means of the integrated coreless transformer technology. The μC compatible interfaces allow a direct connection to the ports of a microcontroller without the need for other components. Each of the 8 high-side power switches is protected against short to Vbb, overload, overtemperature and against overvoltage by an active zener clamp.

The diagnostic logic on the power chip recognizes the overtemperature information of each power transistor. The information is sent via the internal coreless transformer to the pin $\overline{\text{DIAG}}$ at the input interface.

3.2 Power Supply

The IC contains 2 galvanic isolated voltage domains that are independent from each other. The input interface is supplied at VCC and the output stage is supplied at Vbb. The different voltage domains can be switched on at different time. The output stage is only enabled once the input stage enters a stable state.

3.3 Output Stage

Each channel contains a high-side vertical power FET that is protected by embedded protection functions.

The continuous current for each channel is 1.2A (all channels ON).

3.3.1 Output Stage Control

Each output is independently controlled by an output latch and a common reset line via the pin $\overline{\text{DIS}}$ that disables all eight outputs and reset the latches. The parallel input data is transferred to the input latches with a high-to-low transition of the signal $\overline{\text{WR}}$ (write) while the $\overline{\text{CS}}$ is logic low. A low-to-high transition of $\overline{\text{CS}}$ transfers then the data of the input latches to the output buffer.

3.3.2 Power Transistor Overvoltage Protection

Each of the eight output stages has its own zener clamp that causes a voltage limitation at the power transistor when solenoid loads are switched off. V_{ON} is then clamped to 47V (min.).

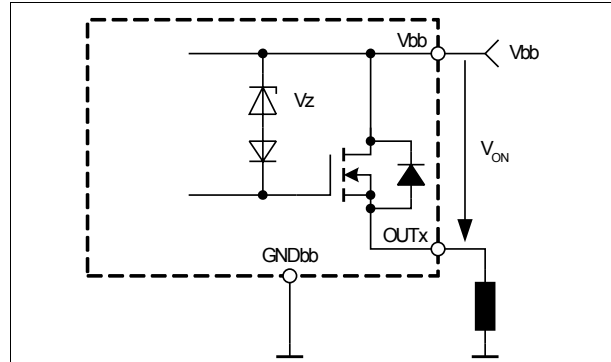

Figure 3 Inductive and overvoltage output clamp (each channel)

Energy is stored in the load inductance during an inductive load switch-off.

$$E_L = 1/2 \times L \times I_L^2$$

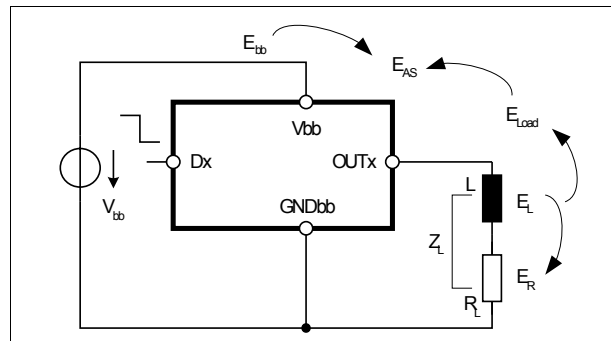

Figure 4 Inductive load switch-off energy dissipation (each channel)

While demagnetizing the load inductance, the energy dissipation in the DMOS is

$$E_{\text{AS}} = E_{\text{bb}} + E_L - E_R = V_{\text{ON(CL)}} \times i_L(t) dt$$

with an approximate solution for $R_L > 0\Omega$:

$$E_{\text{AS}} = \frac{I_L \times L}{2 \times R_L} \times (V_{\text{bb}} + |V_{\text{ON(CL)}}|) \times \ln\left(1 + \frac{I_L \times R_L}{|V_{\text{ON(CL)}}|}\right)$$

3.3.3 Power Transistor Overcurrent Protection

The outputs are provided with a current limitation that enters a repetitive switched mode after an initial peak

current has been exceeded. The initial peak short circuit current limit is set to $I_{L(SCp)}$. During the repetitive mode short circuit current the limit is set to $I_{L(SCr)}$. If this operation leads to an overtemperature condition, a second protection level ($T_j > 135^\circ\text{C}$) will change the output into a low duty cycle PWM (selective thermal shutdown with restart) to prevent critical chip temperatures.

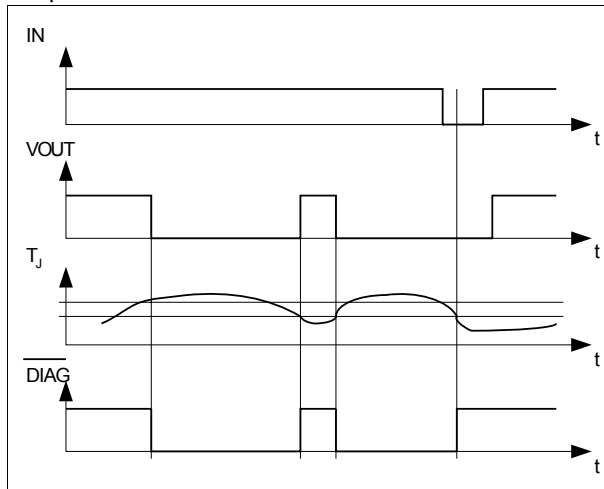

Figure 5 Overtemperature detection

The following figures show the timing for a turn on into short circuit and a short circuit in on-state. Heating up of the chip may require several milliseconds, depending on external conditions.

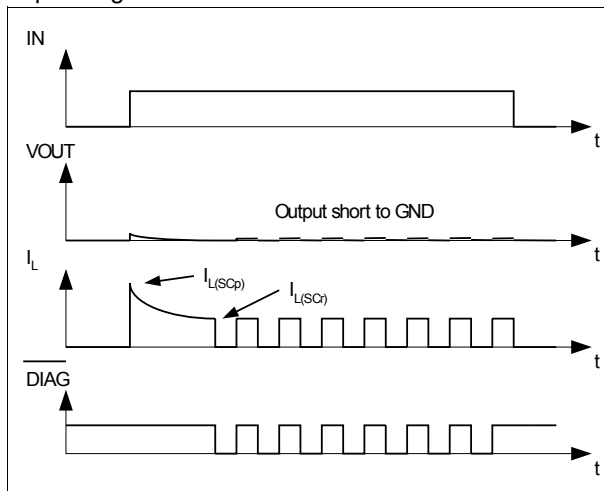

Figure 6 Turn on into short circuit, shut down by overtemperature, restart by cooling

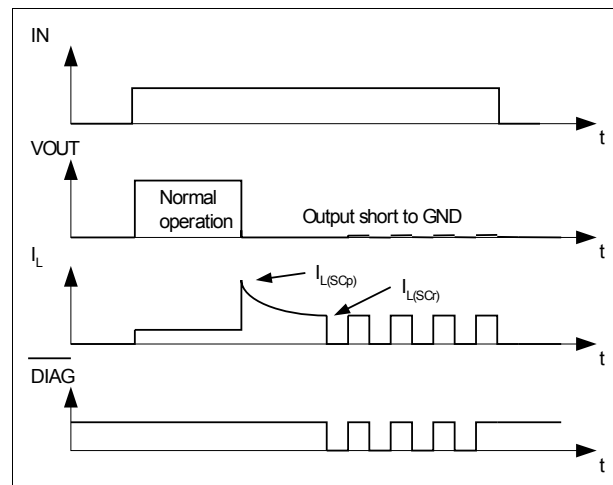

Figure 7 Short circuit in on-state, shut down by overtemperature, restart by cooling

3.4 Common Diagnostic Output

The overtemperature detection information are OR-wired in the common diagnostic output block. The information is sent via the integrated coreless transformer to the input interface. The output stage at pin DIAG has an open drain functionality combined with a current source.

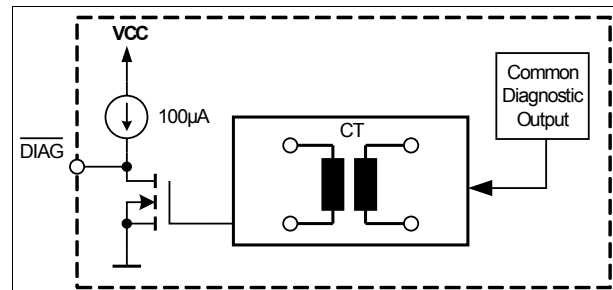

Figure 8 Common diagnostic output

3.5 Parallel Interface

The ISO1H815G contains a parallel interface that can be directly controlled by the microcontroller output ports. The parallel interface can also be switched over to a direct control that allows direct changes of the outputs OUT0 ... OUT7 by means of the corresponding inputs D0 ... D7 without additional logic signals. To activate the parallel direct control mode pin \overline{CS} and pin \overline{WR} have to be connected both to ground.

3.5.1 Parallel Interface Signal Description

\overline{CS} - Chip select. The system microcontroller selects the ISO1H815G by means of the \overline{CS} pin. Whenever the pin is in a logic low state, data can be transferred from the μC .

\overline{CS} High to low transition:



- Parallel input data can be written in from then on

\overline{CS} Low to high transition:



- The data in the input latches is transferred to the output buffer

\overline{WR} - Write. The system controller enables the write procedure in the ISO1H815G by means of the signal \overline{WR} . A logic low state signal at pin \overline{WR} writes the input data into the input latches when the \overline{CS} pin is in a logic low state.

\overline{WR} Logic low level:



- Parallel input data at the pins D0 - D7 is written into the input latches

\overline{WR} Logic high level:



- The parallel input data is latched in the input latches. Any changes at the pins D0 - D7 after the low-to-high transition of \overline{WR} do not affect the input latches.

D0 ... D7 - Parallel input. Parallel data bits are fed into the pins D0 ... D7. The data is written into the input latches when \overline{WR} is logic low.

3.5.2 μC Control Mode

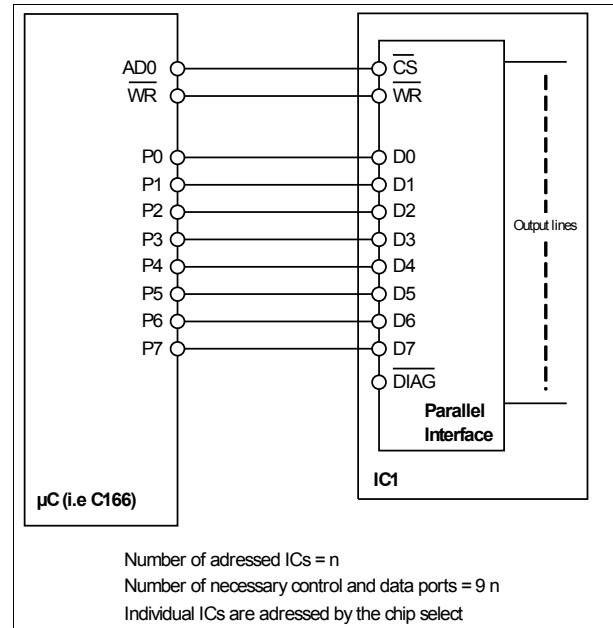

Figure 9 Parallel bus configuration

3.5.3 Direct Control Mode

Beside the use of the parallel μC compatible interface a parallel direct control mode can be chosen. In this mode the output OUT0...OUT7 can be directly controlled via the inputs D0...D7 without the need for additional logic signals. To activate this mode pin \overline{CS} and \overline{WR} need to be connected to ground.

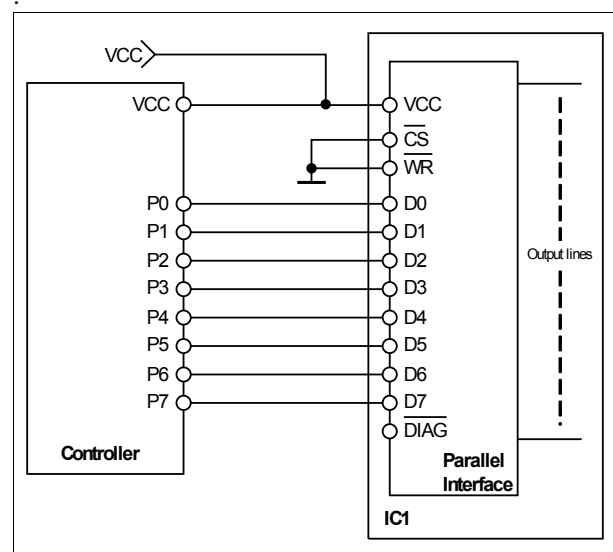

Figure 10 Parallel Direct Control

3.6 Parallel Interface Timing

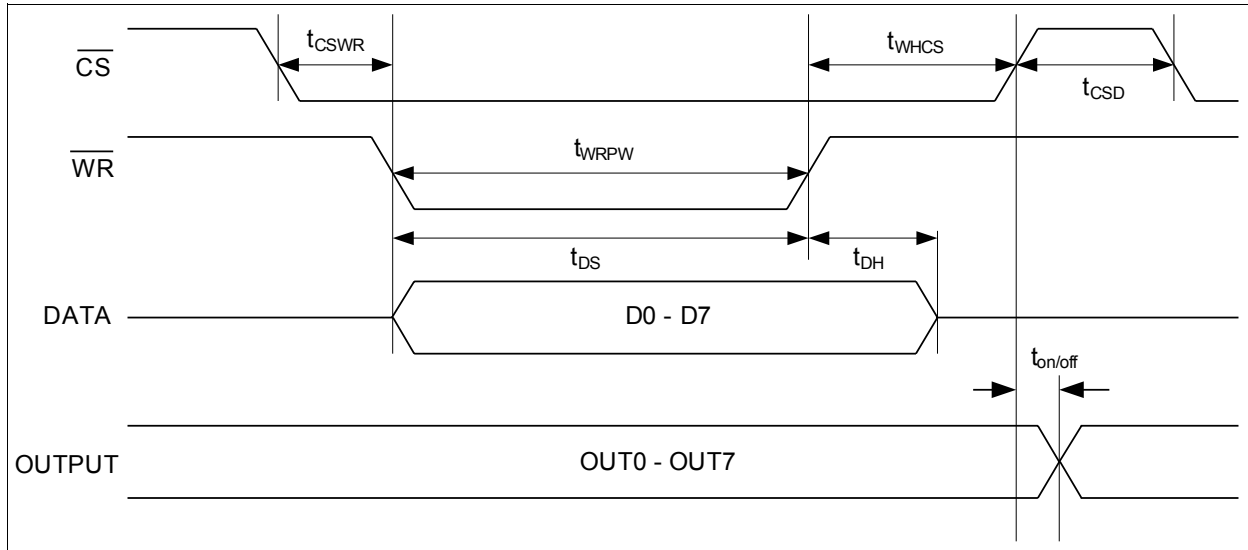

Figure 11 Parallel input - output timing diagram

3.7 Transmission Failure Detection

There is a failure detection unit integrated to ensure also a stable functionality during the integrated coreless transformer transmission. This unit decides whether the transmitted data is valid or not. If four times serial data coming in from the internal registers is not accepted, the output stages are switched off until the next valid data is received.

4 Electrical Characteristics

Note: All voltages at pins 2 to 14 are measured with respect to ground GNDCC (pin 15). All voltages at pin 20 to pin 36 and TAB are measured with respect to ground GNDbb (pin 19). The voltage levels are valid if other ratings are not violated. The two voltage domains V_{CC} and V_{bb} are internally galvanic isolated.

4.1 Absolute Maximum Ratings

Note: Absolute maximum ratings are defined as ratings, which when being exceeded may lead to destruction of the integrated circuit. For the same reason make sure, that any capacitor that will be connected to pin 2 (V_{CC}) and TAB (V_{bb}) is discharged before assembling the application circuit. Supply voltages higher than $V_{bb(AZ)}$ require an external current limit for the GNDbb pin, e.g. with a 15Ω resistor in GNDbb connection. Operating at absolute maximum ratings can lead to a reduced lifetime.

Parameter at $T_j = -40 \dots 135^\circ\text{C}$, unless otherwise specified	Symbol	Limit Values		Unit
		min.	max.	
Supply voltage input interface (V_{CC})	V_{CC}	-0.5	6.5	V
Supply voltage output interface (V_{bb})	V_{bb}	-1 ¹⁾	45	
Continuous voltage at data inputs (D0 ... D7)	V_{Dx}	-0.5	6.5	
Continuous voltage at pin \overline{CS}	V_{CS}	-0.5	6.5	
Continuous voltage at pin \overline{WR}	V_{WR}	-0.5	6.5	
Continuous voltage at pin \overline{DIS}	V_{DIS}	-0.5	6.5	
Continuous voltage at pin \overline{DIAG}	V_{DIAG}	-0.5	6.5	
Load current (short-circuit current)	I_L	—	self limited	
Reverse current through GNDbb ¹⁾	I_{GNDbb}	-1.6	—	
Operating Temperature	T_j	-25	internal limited	°C
Storage Temperature	T_{stg}	-50	150	
Power Dissipation ²⁾	P_{tot}	—	3.3	W
Inductive load switch-off energy dissipation ³⁾ single pulse, $T_j = 125^\circ\text{C}$, $I_L = 1.2\text{A}$ one channel active all channel simultaneously active (each channel)	E_{AS}	—	5	J
		0.5		
Load dump protection ³⁾ $V_{loadDump}^{4)} = V_A + V_S$ $V_{IN} = \text{low or high}$ $t_d = 400\text{ms}$, $R_i = 2\Omega$, $R_L = 27\Omega$, $V_A = 13.5\text{V}$ $t_d = 350\text{ms}$, $R_i = 2\Omega$, $R_L = 57\Omega$, $V_A = 27\text{V}$	$V_{Loaddump}$		90 117	V
Electrostatic discharge voltage (Human Body Model) according to JESD22-A114-B	V_{ESD}		2	kV
Electrostatic discharge voltage (Charge Device Model) according to ESD STM5.3.1 - 1999	V_{ESD}		1	kV
Continuous reverse drain current ¹⁾³⁾ , each channel	I_S	—	4	A

1) defined by P_{tot}

2) Device on $50\text{mm} \times 50\text{mm} \times 1.5\text{mm}$ epoxy PCB FR4 with 6cm^2 (one layer, $70\mu\text{m}$ thick) copper area for drain connection. PCB is vertical without blown air.

3) not subject to production test, specified by design

4) $V_{Loaddump}$ is setup without the DUT connected to the generator per ISO7637-1 and DIN40839

4.2 Thermal Characteristics

Parameter at $T_j = -25 \dots 125^\circ\text{C}$, $V_{bb} = 15 \dots 30\text{V}$, $V_{CC} = 3.0 \dots 5.5\text{V}$, unless otherwise specified	Symbol	Limit Values			Unit	Test Condition
		min.	typ.	max.		
Thermal resistance junction - case	R_{thJC}	—	—	1.5	K/W	
Thermal resistance @ min. footprint	$R_{th(JA)}$	—	—	50		
Thermal resistance @ 6cm ² cooling area ¹⁾	$R_{th(JA)}$	—	—	38		

1) Device on 50mm*50mm*1.5mm epoxy PCB FR4 with 6cm² (one layer, 70μm thick) copper area for drain connection. PCB is vertical without blown air.

4.3 Load Switching Capabilities and Characteristics

Parameter at $T_j = -25 \dots 125^\circ\text{C}$, $V_{bb} = 15 \dots 30\text{V}$, $V_{CC} = 3.0 \dots 5.5\text{V}$, unless otherwise specified	Symbol	Limit Values			Unit	Test Condition
		min.	typ.	max.		
On-state resistance, $I_L = 0.5\text{A}$, each channel $T_j = 25^\circ\text{C}$ $T_j = 125^\circ\text{C}$ two parallel channels, $T_j = 25^\circ\text{C}$: ¹⁾ four parallel channels, $T_j = 25^\circ\text{C}$: ¹⁾	R_{ON}	—	150 270 75 38	200 320 100 50	mΩ	
Nominal load current Device on PCB 38K/W, $T_a = 85^\circ\text{C}$, $T_j < 125^\circ\text{C}$ one channel: ¹⁾ two parallel channels: ¹⁾ four parallel channels: ¹⁾	$I_{L(NOM)}$		1.4 2.2 4.4			A
Turn-on time to 90% V_{OUT} ²⁾ $R_L = 47\Omega$, $V_{Dx} = 0$ to 5V	t_{on}	—	64	120	μs	
Turn-off time to 10% V_{OUT} ²⁾ $R_L = 47\Omega$, $V_{Dx} = 5$ to 0V	t_{off}	—	89	170		
Slew rate on 10 to 30% V_{OUT} $R_L = 47\Omega$, $V_{bb} = 15\text{V}$	dV/dt_{on}	—	1	2	V/μs	
Slew rate off 70 to 40% V_{OUT} $R_L = 47\Omega$, $V_{bb} = 15\text{V}$	$-dV/dt_{off}$	—	1	2		

1) not subject to production test, specified by design

2) The turn-on and turn-off time includes the switching time of the high-side switch and the transmission time via the coreless transformer in normal operating mode. During a failure on the coreless transformer transmission turn-on or turn-off time can increase by up to 50μs.

4.4 Operating Parameters

Parameter at $T_j = -25 \dots 125^\circ\text{C}$, $V_{bb} = 15 \dots 30\text{V}$, $V_{CC} = 3.0 \dots 5.5\text{V}$, unless otherwise specified	Symbol	Limit Values			Unit	Test Condition
		min.	typ.	max.		
Common mode transient immunity ¹⁾	$\Delta V_{ISO}/dt$	-25	-	25	kV/μs	$\Delta V_{ISO} = 200\text{V}$
Magnetic field immunity ¹⁾	H_{IM}	100			A/m	IEC61000-4-8

Electrical Characteristics

Voltage domain V_{bb} (Output interface)	Operating voltage	V_{bb}	11	—	35	V	
	Undervoltage shutdown	$V_{bb(under)}$	7	—	10.5		
	Undervoltage restart	$V_{bb(u_rst)}$	—	—	11		
	Undervoltage hysteresis	$\Delta V_{bb(under)}$	—	0.5	—		
	Undervoltage current	$I_{bb(uvlo)}$	—	1	2.5	mA	$V_{bb} < 7V$
	Operating current	I_{GNDL}	—	10	14	mA	All Channels ON - no load
	Leakage output current (included in $I_{bb(off)}$) $V_{Dx} = \text{low}$, each channel	$I_{L(off)}$	—	5	30	μA	
Voltage domain V_{CC} (Input interface)	Operating voltage	V_{CC}	3.0	—	5.5	V	
	Undervoltage shutdown	$V_{CC(under)}$	2.5	—	2.9		
	Undervoltage restart	$V_{CC(u_rst)}$	—	—	3		
	Undervoltage hysteresis	$\Delta V_{CC(under)}$	—	0.1	—		
	Undervoltage current	$I_{CC(uvlo)}$	—	1	2	mA	$V_{CC} < 2.5V$
	Operating current	$I_{CC(on)}$	—	4.5	6	mA	

1) not subject to production test

4.5 Output Protection Functions

Parameter ¹⁾ at $T_j = -25 \dots 125^\circ\text{C}$, $V_{bb}=15\dots 30\text{V}$, $V_{CC}=3.0\dots 5.5\text{V}$, unless otherwise specified	Symbol	Limit Values			Unit	Test Condition
		min.	typ.	max.		
Initial peak short circuit current limit, each channel $T_j = -25^\circ\text{C}$, $V_{bb} = 30\text{V}$, $t_m = 700\mu\text{s}$ $T_j = 25^\circ\text{C}$ $T_j = 125^\circ\text{C}$ two parallel channels: ³⁾ four parallel channels: ³⁾	$I_{L(SCP)}$	— — 1.4	— 3.0 —	4.5 — —	A	
		twice the current of one channel four times the current of one channel				
Repetitive short circuit current limit ³⁾ $T_j = T_{jt}$ (see timing diagrams) each channel: two parallel channels: ³⁾ four parallel channels: ³⁾	$I_{L(SCr)}$	—	2.2 2.2 2.2	—		
Output clamp (inductive load switch off) at $V_{OUT} = V_{bb} - V_{ON(CL)}$	$V_{ON(CL)}$	47	53	60	V	
Overvoltage protection	$V_{bb(AZ)}$	47	—	—		
Thermal overload trip temperature ²⁾³⁾	T_{jt}	135	—	—	°C	
Thermal hysteresis ³⁾	ΔT_{jt}	—	10	—	K	

- 1) Integrated protection functions are designed to prevent IC destruction under fault conditions described in the data sheet. Fault conditions are considered as “outside” normal operating range. Protection functions are not designed for continuous repetitive operation.
- 2) Higher operating temperature at normal function for each channel available
- 3) not subject to production test, specified by design

4.6 Diagnostic Characteristics at pin DIAG

Parameter at $T_j = -25 \dots 125^\circ\text{C}$, $V_{bb}=15\dots 30\text{V}$, $V_{CC}=3.0\dots 5.5\text{V}$, unless otherwise specified	Symbol	Limit Values			Unit	Test Condition
		min.	typ.	max.		
Common diagnostic sink current (overtemperature of any channel) $T_j = 135^\circ\text{C}$	$I_{diagsink}$			5	mA	$V_{diagon} < 0.25 \times V_{CC}$
Common diagnostic source current	$I_{diagsource}$		100		μA	

4.7 Input Interface

Parameter at $T_j = -25 \dots 125^\circ\text{C}$, $V_{bb}=15\dots 30\text{V}$, $V_{CC}=3.0\dots 5.5\text{V}$, unless otherwise specified	Symbol	Limit Values			Unit	Test Condition
		min.	typ.	max.		
Input low state voltage (D0 ... D7, $\overline{\text{DIS}}$, $\overline{\text{CS}}$, $\overline{\text{WR}}$)	V_{IL}	-0.3	—	$0.3 \times V_{CC}$	V	
Input high state voltage (D0 ... D7, $\overline{\text{DIS}}$, $\overline{\text{CS}}$, $\overline{\text{WR}}$)	V_{IH}	$0.7 \times V_{CC}$	—	$V_{CC} + 0.3$		
Input voltage hysteresis (D0 ... D7, $\overline{\text{DIS}}$, $\overline{\text{CS}}$, $\overline{\text{WR}}$)	V_{IHys}		100		mV	
Input pull down current (D0 ... D7, $\overline{\text{DIS}}$)	I_{idown}		100		μA	
Input pull up current ($\overline{\text{CS}}$, $\overline{\text{WR}}$)	$-I_{Iup}$		100			
Output disable time (transition $\overline{\text{DIS}}$ to logic low) ¹⁾²⁾ Normal operation Turn-off time to 10% V_{OUT} $R_L = 47\Omega$	t_{DIS}	---	85	170	μs	
Output disable time (transition $\overline{\text{DIS}}$ to logic low) ¹⁾²⁾³⁾ Disturbed operation Turn-off time to 10% V_{OUT} $R_L = 47\Omega$	t_{DIS}	---	---	230		

- 1) The time includes the turn-on/off time of the high-side switch and the transmission time via the coreless transformer.
- 2) If Pin $\overline{\text{DIS}}$ is set to low the outputs are set to low; after $\overline{\text{DIS}}$ set to high a new write cycle is necessary to set the output again.
- 3) The parameter is not subject to production test - verified by design/characterization

4.8 Parallel Interface Input Timing

Parameter at $T_j = -25 \dots 125^\circ\text{C}$, $V_{bb}=15\dots 30\text{V}$, $V_{CC}=3.0\dots 5.5\text{V}$, unless otherwise specified	Symbol	Limit Values			Unit	Test Condition
		min.	typ.	max.		
$\overline{\text{WR}}$ pulse width	t_{WRPW}	20	—	—	ns	
Data setup time before $\overline{\text{WR}}$	t_{DS}	20	—	—		
Data hold time after $\overline{\text{WR}}$	t_{DH}	10	—	—		
Chip select valid to $\overline{\text{WR}}$	t_{CSWR}	0	—	—		
$\overline{\text{WR}}$ logic high to $\overline{\text{CS}}$ logic high	t_{WHCS}	10	—	—		
Delay to next $\overline{\text{CS}}$ cycle	t_{CSD}	10	—	—		

4.9 Reverse Voltage

Parameter at $T_j = -25 \dots 125^\circ\text{C}$, $V_{bb}=15\dots 30\text{V}$, $V_{CC}=3.0\dots 5.5\text{V}$, unless otherwise specified	Symbol	Limit Values			Unit	Test Condition
		min.	typ.	max.		
Reverse voltage ¹⁾²⁾ $R_{GND} = 0 \Omega$ $R_{GND} = 150 \Omega$	$-V_{bb}$	—	—	1 45	V	
Diode forward on voltage $I_F = 1.25\text{A}$, $V_{Dx} = \text{low}$, each channel	$-V_{ON}$	—	—	1.2		

1) defined by P_{tot}

2) not subject to production test, specified by design

4.10 Isolation and Safety-Related Specification

Parameter	Value	Unit	Conditions
Measured from input terminals to output terminals, unless otherwise specified			
Rated dielectric isolation voltage V_{ISO}	500	V_{AC}	1 - minute duration ¹⁾
Short term temporary overvoltage	1250	V	5s acc. DIN EN60664-1 ¹⁾
Minimum external air gap (clearance)	2.6	mm	shortest distance through air.
Minimum external tracking (creepage)	2.6	mm	shortest distance path along body.
Minimum Internal Gap	0.01	mm	Insulation distance through insulation

1) The parameter is not subject to production test, verified by characterization; Production Test with 1100V, 100ms duration

4.11 Reliability

For Qualification Report please contact your local Infineon Technologies office!

Typ. on-state resistance

$R_{ON} = f(T_j)$; $V_{bb} = 15V$; $V_{in} = \text{high}$

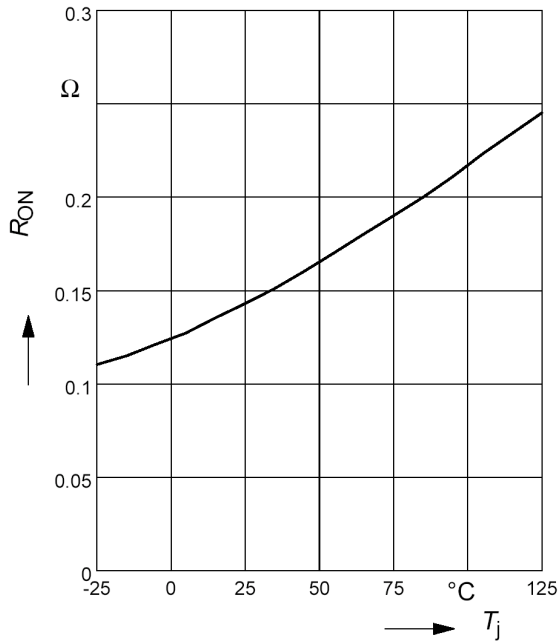

Typ. on-state resistance

$R_{ON} = f(V_{bb})$; $I_L = 0.5A$; $V_{in} = \text{high}$

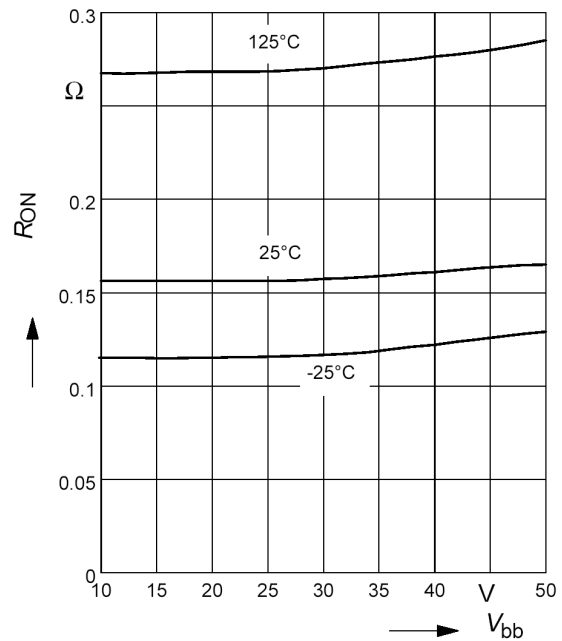

Typ. initial peak short circuit current limit

$I_{L(SCP)} = f(T_j)$; $V_{bb} = 24V$

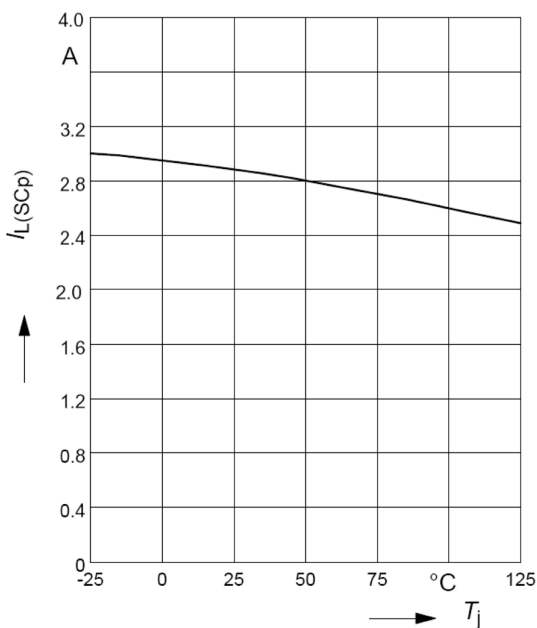

Maximum allowable load inductance for a single switch off, calculated
 $L = f(I_L)$; $T_{\text{istart}} = 125^\circ\text{C}$, $V_{\text{bb}}=24\text{V}$, $R_L=0\Omega$

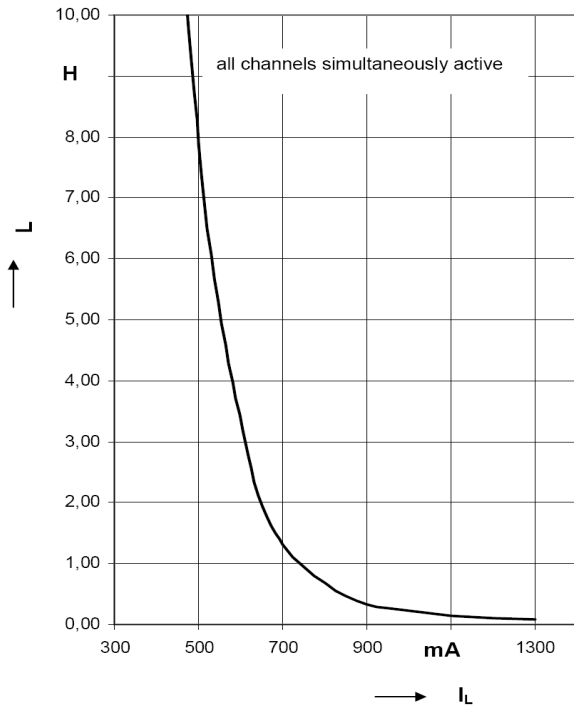

Maximum allowable inductive switch-off Energy, single pulse
 $E_{\text{AS}} = f(I_L)$; $T_{\text{istart}} = 125^\circ\text{C}$, $V_{\text{bb}}=24\text{V}$

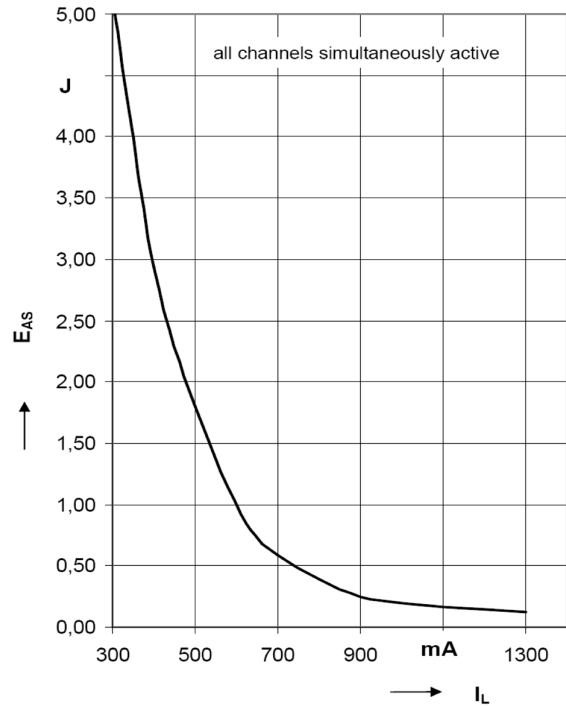

Typ. transient thermal impedance $Z_{\text{thJA}}=f(t_p)$ @ min. footprint

Parameter: $D=t_p/T$

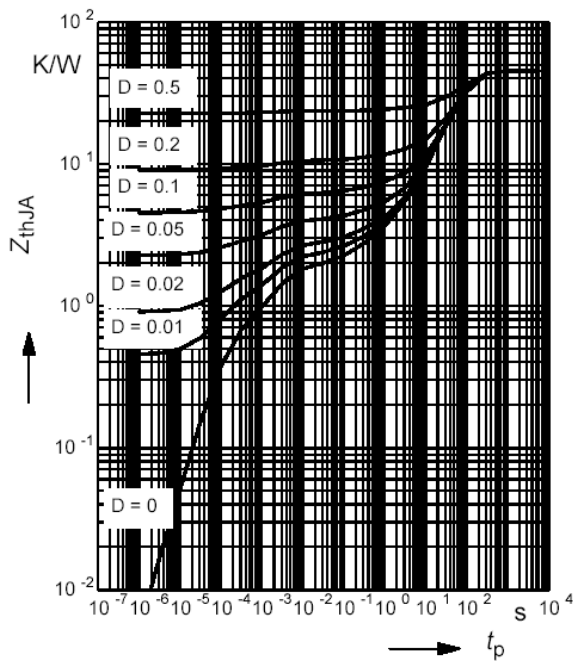

Typ. transient thermal impedance $Z_{\text{thJA}}=f(t_p)$ @ 6cm² heatsink area

Parameter: $D=t_p/T$

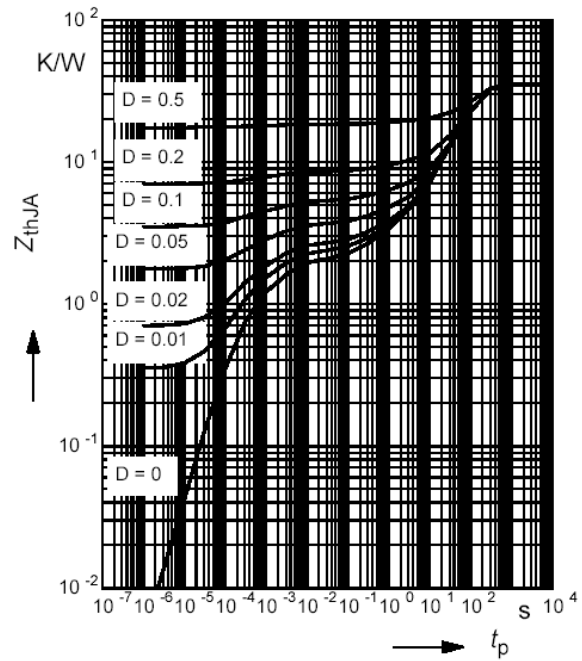

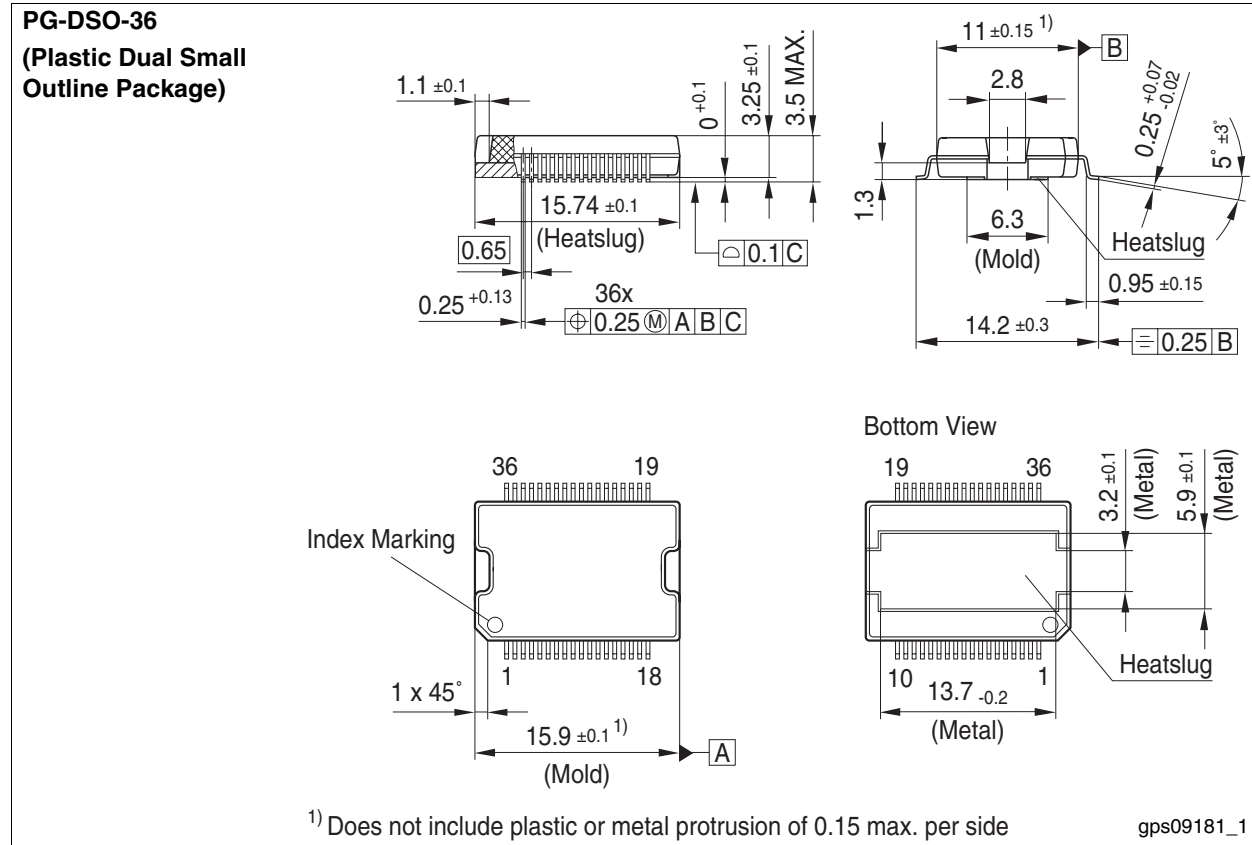
5 Package Outlines

Figure 12 PG-DSO-36

Total Quality Management

Qualität hat für uns eine umfassende Bedeutung. Wir wollen allen Ihren Ansprüchen in der bestmöglichen Weise gerecht werden. Es geht uns also nicht nur um die Produktqualität – unsere Anstrengungen gelten gleichermaßen der Lieferqualität und Logistik, dem Service und Support sowie allen sonstigen Beratungs- und Betreuungsleistungen.

Dazu gehört eine bestimmte Geisteshaltung unserer Mitarbeiter. Total Quality im Denken und Handeln gegenüber Kollegen, Lieferanten und Ihnen, unserem Kunden. Unsere Leitlinie ist jede Aufgabe mit „Null Fehlern“ zu lösen – in offener Sichtweise auch über den eigenen Arbeitsplatz hinaus – und uns ständig zu verbessern.

Unternehmensweit orientieren wir uns dabei auch an „top“ (Time Optimized Processes), um Ihnen durch größere Schnelligkeit den entscheidenden Wettbewerbsvorsprung zu verschaffen. Geben Sie uns die Chance, hohe Leistung durch umfassende Qualität zu beweisen.

Wir werden Sie überzeugen.

Quality takes on an all-encompassing significance at Semiconductor Group. For us it means living up to each and every one of your demands in the best possible way. So we are not only concerned with product quality. We direct our efforts equally at quality of supply and logistics, service and support, as well as all the other ways in which we advise and attend to you.

Part of this is the very special attitude of our staff. Total Quality in thought and deed, towards co-workers, suppliers and you, our customer. Our guideline is “do everything with zero defects”, in an open manner that is demonstrated beyond your immediate workplace, and to constantly improve.

Throughout the corporation we also think in terms of Time Optimized Processes (top), greater speed on our part to give you that decisive competitive edge.

Give us the chance to prove the best of performance through the best of quality – you will be convinced.

www.infineon.com