

BTS5242-2L

Smart High-Side Power Switch

Automotive Power



Never stop thinking

Table of Contents

1	Overview	3
2	Block Diagram	5
2.1	Terms	6
3	Pin Configuration	7
3.1	Pin Assignment BTS5242-2L	7
3.2	Pin Definitions and Functions	7
4	Electrical Characteristics	8
4.1	Maximum Ratings	8
5	Block Description and Electrical Characteristics	10
5.1	Power Stages	10
5.1.1	Output On-State Resistance	10
5.1.2	Input Circuit	10
5.1.3	Inductive Output Clamp	11
5.1.4	Electrical Characteristics	13
5.2	Thermal Resistance	14
6	Protection Functions	15
6.1	Over Load Protection	15
6.2	Reverse Polarity Protection	16
6.3	Over Voltage Protection	16
6.4	Loss of Ground Protection	16
6.5	Electrical Characteristics	17
7	Diagnosis	18
7.1	ON-State Diagnosis	19
7.2	OFF-State Diagnosis	20
7.3	Electrical Characteristics	21
8	Package Outlines BTS5242-2L	22
9	Revision History	23



1 Overview

Basic Features

- Very low standby current
- 3.3 V and 5 V compatible logic pins
- Improved electromagnetic compatibility (EMC)
- Stable behavior at under voltage
- Logic ground independent from load ground
- Secure load turn-off while logic ground disconnected
- Very low leakage current from OUT to GND
- Green Product (RoHS compliant)
- AEC Qualified

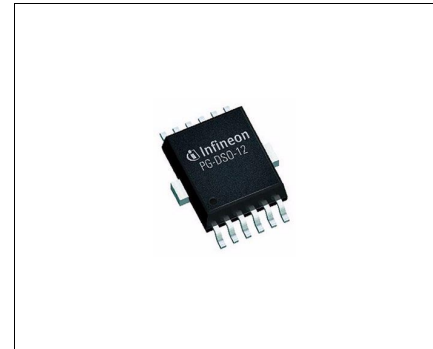

PG-DSO-12-9

Product Summary

The BTS5242-2L is a dual channel high-side power switch in PG-DSO-12-9 package providing embedded protective functions.

The power transistor is built by a N-channel vertical power MOSFET with charge pump. The device is monolithically integrated in Smart SIPMOS technology.

Operating voltage	$V_{bb(ON)}$	4.5 .. 28 V
Over voltage protection	$V_{bb(AZ)}$	41 V
On-State resistance	$R_{DS(ON)}$	25 m Ω
Nominal load current (one channel active)	$I_{L(nom)}$	6 A
Adjustable current limitation	$I_{L(LIM)}$	7 A / 40 A
Current limitation repetitive	$I_{L(SCR)}$	7 A / 40 A
Standby current for whole device with load	$I_{bb(OFF)}$	7.5 μ A

Type	Package	Marking
BTS5242-2L	PG-DSO-12-9	BTS5242-2L

Protective Functions

- Reverse battery protection with external resistor
- Short circuit protection
- Overload protection
- Multi-step current limitation
- Adjustable current limitation
- Thermal shutdown with restart
- Over voltage protection with external resistor
- Loss of ground and loss of V_{bb} protection
- Electrostatic discharge protection (ESD)

Diagnostic Functions

- IntelliSense functionality for each channel
- Proportional load current sense signal by current source
- Open load detection in ON-state by load current sense
- Open load detection in OFF-state by voltage source
- Feedback on over temperature and current limitation in ON-state
- Suppressed thermal toggling of fault signal

Applications

- μ C compatible high-side power switch with diagnostic feedback for 12 V grounded loads
- All types of resistive, inductive and capacitive loads
- Most suitable for loads with high inrush currents, so as lamps
- Replaces electromechanical relays, fuses and discrete circuits

2 Block Diagram

The BTS5242-2L is a dual channel high-side power switch (two times 25 mΩ) in PG-DSO-12-9 power package providing embedded protective functions. Integrated resistors at each input pin (IN1, IN2, CLA) reduce external components.

The load current limitation can be adjusted in two steps by the current limit adjust pin (CLA).

The IntelliSense pins IS1 and IS2 provide a sophisticated diagnostic feedback signal including current sense function, open load in off state and over load alert.

The power transistor is built by a N-channel vertical power MOSFET with charge pump. The inputs are ground referenced CMOS compatible. The device is monolithically integrated in Smart SIPMOS technology.

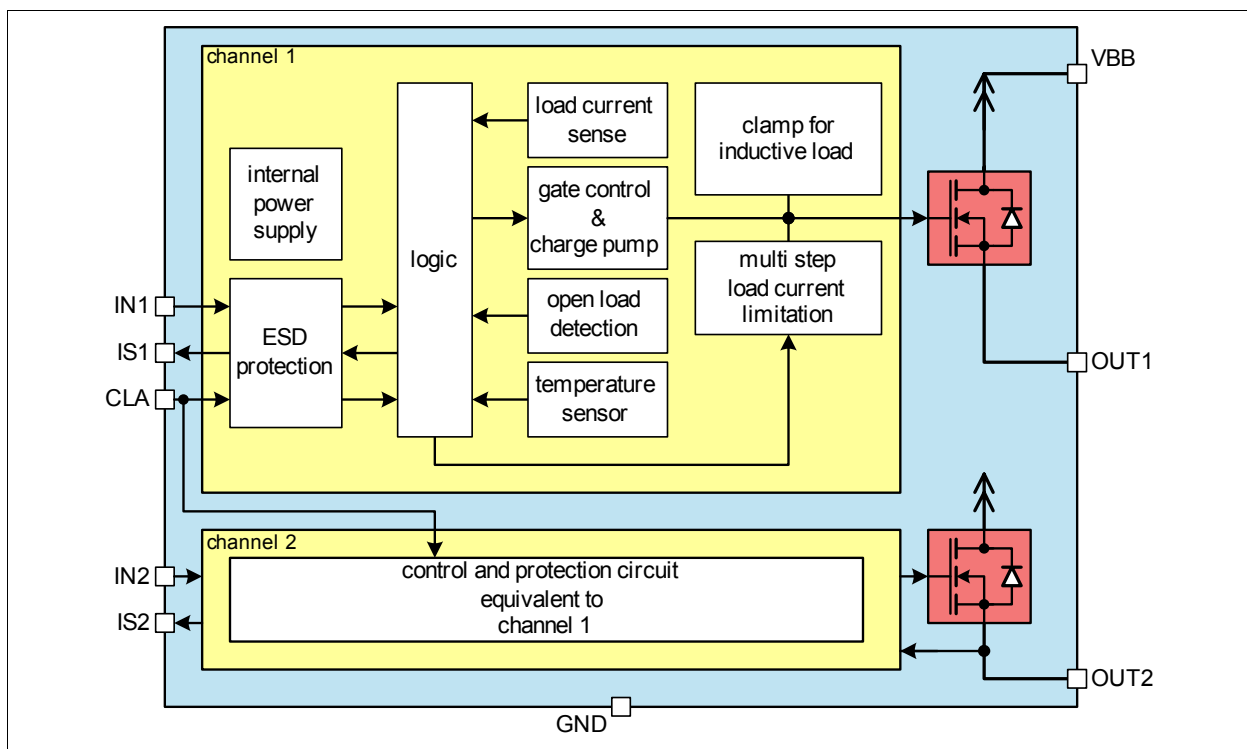

Figure 1 Block Diagram

2.1 Terms

Following figure shows all terms used in this data sheet.

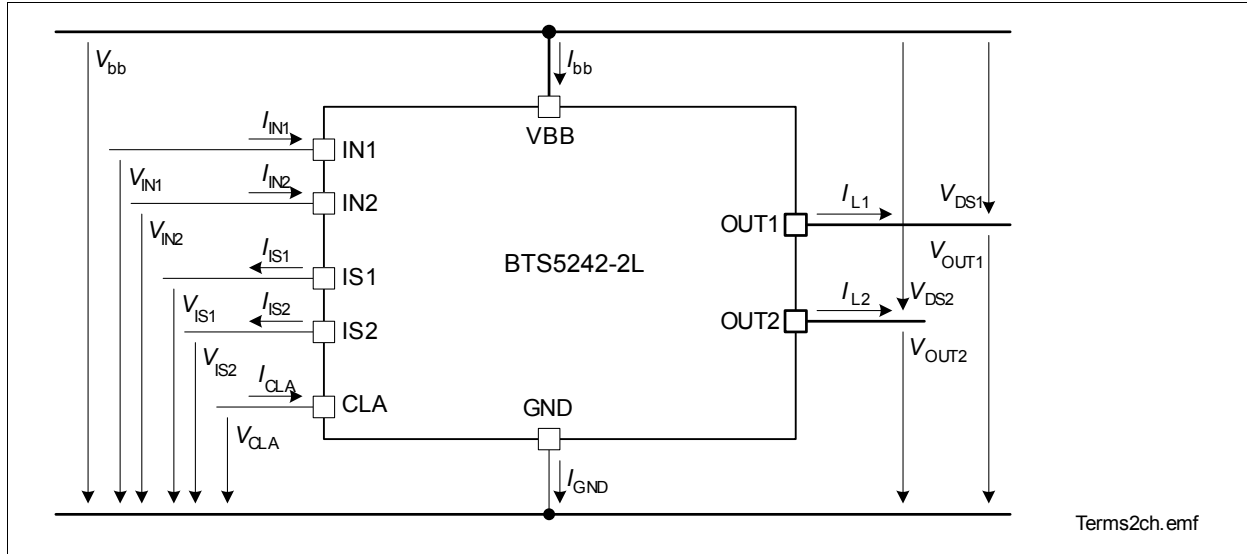

Figure 2 Terms

3 Pin Configuration

3.1 Pin Assignment BTS5242-2L

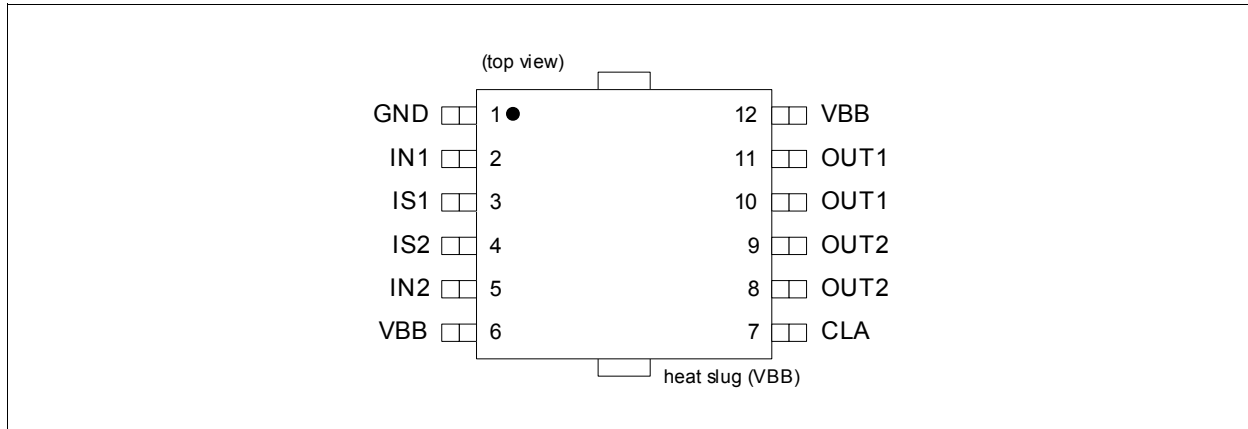

Figure 3 Pin Configuration PG-DSO-12-9

3.2 Pin Definitions and Functions

Pin	Symbol	I/O OD	Function
2	IN1	I	Input signal for channel 1
5	IN2	I	Input signal for channel 2
3	IS1	O	Diagnosis output signal channel 1
4	IS2	O	Diagnosis output signal channel 2
7	CLA	I	Current limit adjust input for channel 1&2
10,11	OUT1 ¹⁾	O	Protected high-side power output channel 1
8, 9	OUT2 ¹⁾	O	Protected high-side power output channel 2
1	GND	-	Ground connection
6,12, heat slug	VBB	-	Positive power supply for logic supply as well as output power supply

1) All output pins of each channel have to be connected

4 Electrical Characteristics

4.1 Maximum Ratings

$T_j = 25\text{ °C}$ (unless otherwise specified)

Pos.	Parameter	Symbol	Limit Values		Unit	Test Conditions
			min.	max.		
Power Supply						
4.1.1	Supply voltage	V_{bb}	–	18	V	$t \leq 100\text{ h}$
			–	28		
4.1.2	Current through ground pin	I_{GND}	-150		mA	$t \leq 2\text{ min}$
4.1.3	Supply voltage for full short circuit protection (single pulse) ($T_j = -40\text{ °C} \dots 150\text{ °C}$)	$V_{bb(SC)}$	0	28	V	$L = 8\text{ }\mu\text{H}$ $R = 0.2\text{ }\Omega$ ¹⁾
4.1.4	Voltage at power transistor	V_{DS}	–	52	V	
4.1.5	Supply Voltage for Load Dump protection	$V_{bb(LD)}$	–	40	V	$R_1 = 2\text{ }\Omega$ ²⁾ $R_L = 2.25\text{ }\Omega$ $R_L = 6.8\text{ }\Omega$
			–	53		
Power Stages						
4.1.6	Load current	I_L		$I_{L(LIM)}$	A	³⁾
4.1.7	Maximum energy dissipation single pulse	E_{AS}	–	130	mJ	⁴⁾ $T_{j(0)} = 150\text{ °C}$ $I_{L(0)} = 6\text{ A}$ $V_{bb} = 12\text{ V}$
4.1.8	Power dissipation (DC)	P_{tot}	–	1.4	W	⁵⁾ $T_a = 85\text{ °C}$ $T_j \leq 150\text{ °C}$
Logic Pins						
4.1.9	Voltage at input pin	V_{IN}	-5 -16	19	V	$t \leq 2\text{ min}$
4.1.10	Current through input pin	I_{IN}	-2.0 -8.0	2.0	mA	$t \leq 2\text{ min}$
4.1.11	Voltage at current limit adjust pin	V_{CLA}	-5 -16	19	V	$t \leq 2\text{ min}$
4.1.12	Current through current limit adjust pin	I_{CLA}	-2.0 -8.0	2.0	mA	$t \leq 2\text{ min}$
4.1.13	Current through sense pin	I_{IS}	-5	10	mA	
Temperatures						
4.1.14	Junction temperature	T_j	-40	150	°C	
4.1.15	Dynamic temperature increase while switching	ΔT_j	–	60	°C	
4.1.16	Storage temperature	T_{stg}	-55	150	°C	

$T_j = 25\text{ °C}$ (unless otherwise specified)

Pos.	Parameter	Symbol	Limit Values		Unit	Test Conditions
			min.	max.		
ESD Susceptibility						
4.1.17	ESD susceptibility HBM	V_{ESD}	-1	1	kV	according to EIA/JESD 22-A 114B
	IN, CLA		-1	1		
	IS		-2	2		
	OUT		-4	4		

- 1) R and L describe the complete circuit impedance including line, contact and generator impedances
- 2) Load Dump is specified in ISO 7637, R_i is the internal resistance of the Load Dump pulse generator
- 3) Current limitation is a protection feature. Operation in current limitation is considered as "outside" normal operating range. Protection features are not designed for continuous repetitive operation.
- 4) Pulse shape represents inductive switch off: $I_L(t) = I_L(0) * (1 - t / t_{peak})$; $0 < t < t_{peak}$. Please see [Figure 8](#)
- 5) Device mounted on PCB (50 mm x 50 mm x 1.5 mm epoxy, FR4) with 6 cm² copper heatsinking area (one layer, 70 μm thick) for V_{bb} connection. PCB is vertical without blown air.

Note: Stresses above the ones listed here may cause permanent damage to the device. Exposure to absolute maximum rating conditions for extended periods may affect device reliability.

Note: Integrated protection functions are designed to prevent IC destruction under fault conditions described in the data sheet. Fault conditions are considered as "outside" normal operating range. Protection functions are not designed for continuous repetitive operation.

5 Block Description and Electrical Characteristics

5.1 Power Stages

The power stages are built by a N-channel vertical power MOSFET (DMOS) with charge pump.

5.1.1 Output On-State Resistance

The on-state resistance $R_{DS(ON)}$ depends on the supply voltage as well as the junction temperature T_j . **Figure 4** shows that dependencies for the typical on-state resistance. The behavior in reverse polarity mode is described in **Section 6.2**.

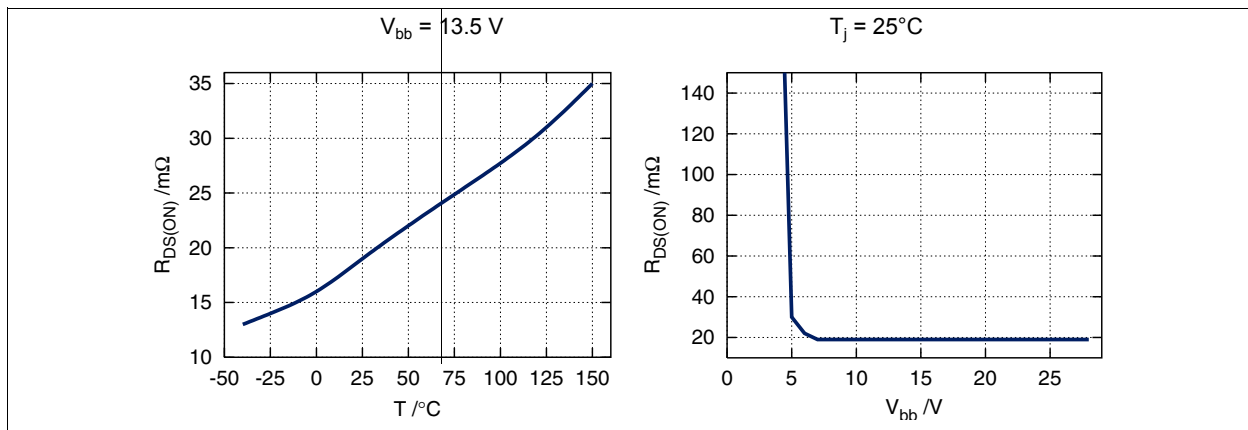

Figure 4 Typical On-State Resistance

5.1.2 Input Circuit

Figure 5 shows the input circuit of the BTS5242-2L. There is an integrated input resistor that makes external components obsolete. The current sink to ground ensures that the device switches off in case of open input pin. The zener diode protects the input circuit against ESD pulses.

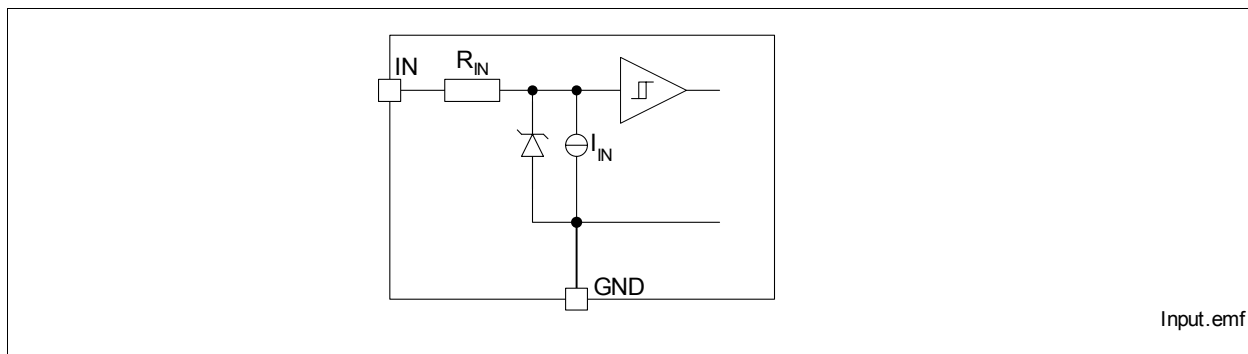

Figure 5 Input Circuit (IN1 and IN2)

A high signal at the input pin causes the power DMOS to switch on with a dedicated slope, which is optimized in terms of EMC emission.

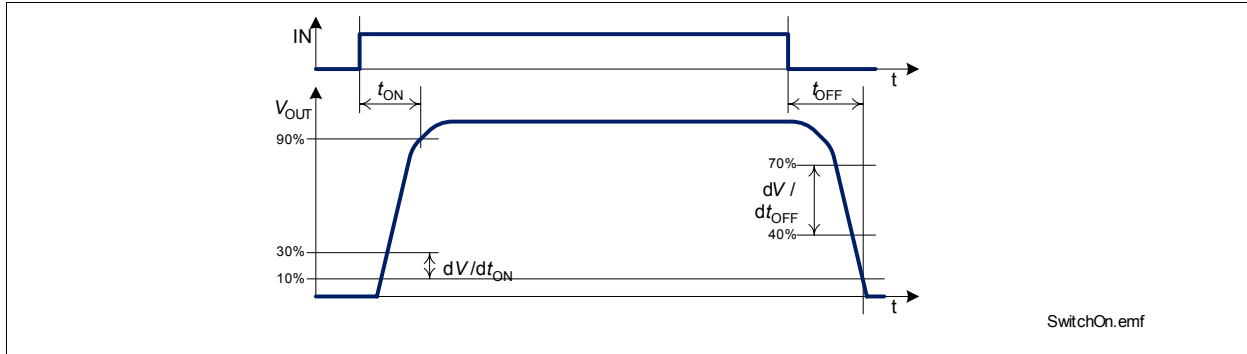

Figure 6 Switching a Load (resistive)

5.1.3 Inductive Output Clamp

When switching off inductive loads with high-side switches, the voltage V_{OUT} drops below ground potential, because the inductance intends to continue driving the current.

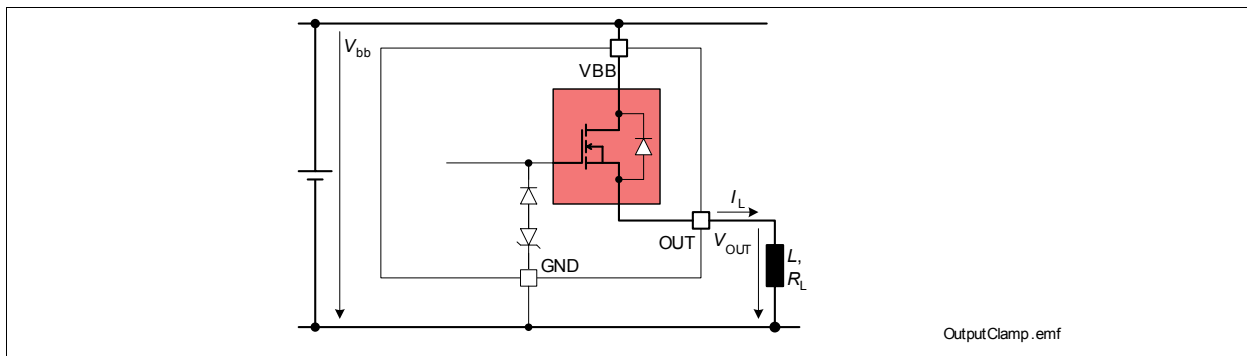

Figure 7 Output Clamp (OUT1 and OUT2)

To prevent destruction of the device, there is a voltage clamp mechanism implemented that keeps that negative output voltage at a certain level ($V_{OUT(CL)}$). See [Figure 7](#) and [Figure 8](#) for details. Nevertheless, the maximum allowed load inductance is limited.

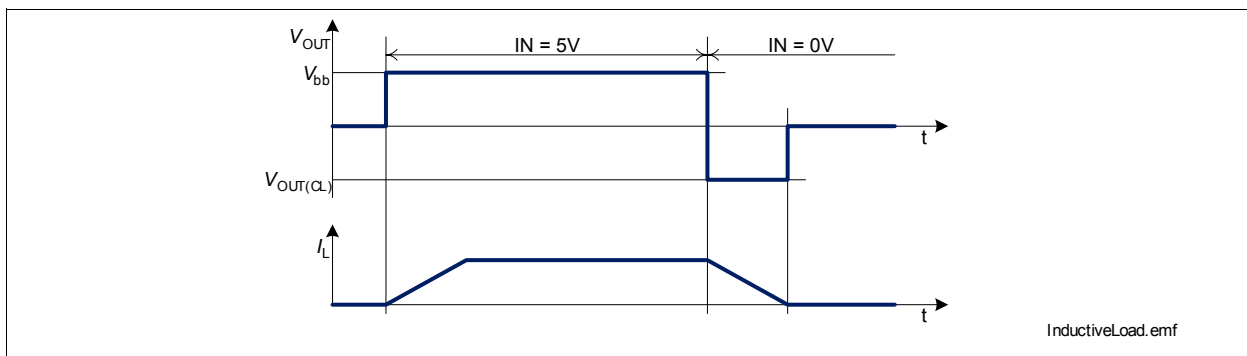

Figure 8 Switching an Inductance

Maximum Load Inductance

While demagnetization of inductive loads, energy has to be dissipated in the BTS5242-2L. This energy can be calculated with following equation:

$$E = (V_{bb} - V_{OUT(CL)}) \cdot \left[\frac{V_{OUT(CL)}}{R_L} \cdot \ln \left(1 - \frac{R_L \cdot I_L}{V_{OUT(CL)}} \right) + I_L \right] \cdot \frac{L}{R_L}$$

Following equation simplifies under the assumption of $R_L = 0$:

$$E = \frac{1}{2} L I_L^2 \cdot \left(1 - \frac{V_{bb}}{V_{OUT(CL)}} \right)$$

The energy, which is converted into heat, is limited by the thermal design of the component. See [Figure 9](#) for the maximum allowed energy dissipation.

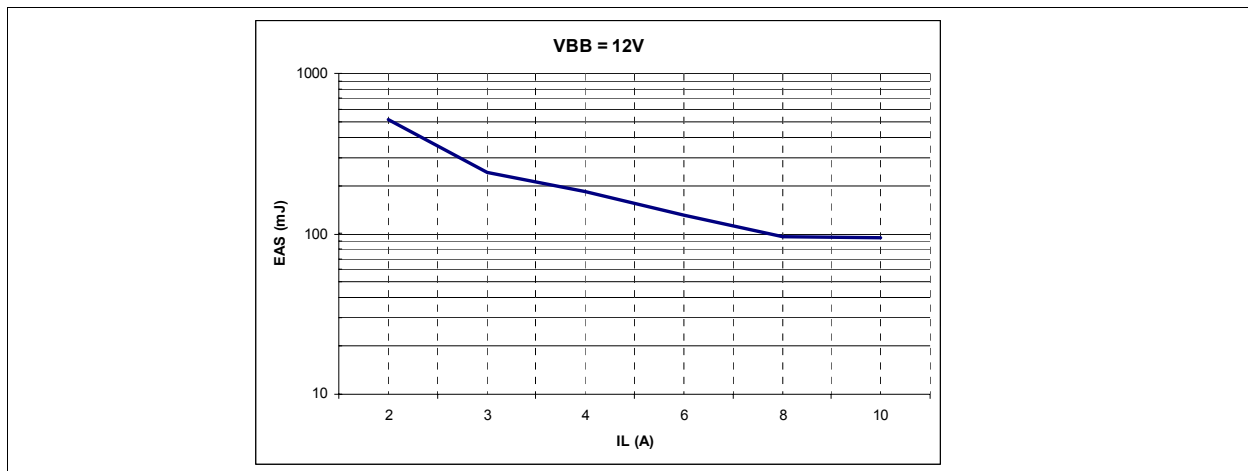

Figure 9 Maximum energy dissipation single pulse, $T_{j,Start} = 150^{\circ}\text{C}$

Block Description and Electrical Characteristics
5.1.4 Electrical Characteristics
 $V_{bb} = 9\text{ V to }16\text{ V}$, $T_j = -40\text{ °C to }+150\text{ °C}$ (unless otherwise specified)

 typical values: $V_{bb} = 13.5\text{ V}$, $T_j = 25\text{ °C}$

Pos.	Parameter	Symbol	Limit Values			Unit	Test Conditions
			min.	typ.	max.		
General							
5.1.1	Operating voltage	V_{bb}	4.5	–	28	V	$V_{IN} = 4.5\text{ V}$ $R_L = 12\ \Omega$ $V_{DS} < 0.5\text{ V}$
5.1.2	Operating current one channel all channels	I_{GND}	–	1.6	4	mA	$V_{IN} = 5\text{ V}$ $I_L = 5\text{ A}$
			–	3.2	8		
5.1.3	Standby current for whole device with load	$I_{bb(OFF)}$	–	–	–	μA	$V_{IN} = 0\text{ V}$ $V_{CLA} = 0\text{ V}$ $V_{OUT} < V_{OUT(OL)}$ $T_j = 25\text{ °C}$ $T_j = 105\text{ °C}$ $T_j = 150\text{ °C}$
Output characteristics							
5.1.4	On-State resistance per channel	$R_{DS(ON)}$	–	19 35	25 48	$\text{m}\Omega$	$I_L = 5\text{ A}$ $T_j = 25\text{ °C}$ $T_j = 150\text{ °C}$
5.1.5	Output voltage drop limitation at small load currents	$V_{DS(NL)}$	–	40	–	mV	$I_L < 0.5\text{ A}$
5.1.6	Nominal load current per channel one channel active two channels active	$I_{L(nom)}$	5.5 4.1	6 4.5	– –	A	$T_a = 85\text{ °C}$ $T_j \leq 150\text{ °C}^{1) 2)}$
			ISO load current per channel one channel active two channels active	$I_{L(ISO)}$	13 13		
5.1.7	Output clamp	$V_{OUT(CL)}$	-24	-20	-17	V	$I_L = 40\text{ mA}$
5.1.8	Output leakage current per channel	$I_{L(OFF)}$	–	1.5	8	μA	$V_{IN} = 0\text{ V}$
Input characteristics							
5.1.9	Input resistance for pin IN	R_{IN}	2.0	3.5	5.5	$\text{k}\Omega$	
5.1.10	L-input level for pin IN	$V_{IN(L)}$	-0.3	–	1.0	V	
5.1.11	H-input level for pin IN	$V_{IN(H)}$	2.4	–	–	V	
5.1.12	Hysteresis for pin IN	ΔV_{IN}	–	0.5	–	V	³⁾
5.1.13	L-input current for pin IN	$I_{IN(L)}$	3	–	40	μA	$V_{IN} = 0.4\text{ V}$
5.1.14	H-input current for pin IN	$I_{IN(H)}$	20	50	90	μA	$V_{IN} = 5\text{ V}$
Timings							
5.1.15	Turn-on time to 90% V_{bb}	t_{ON}	–	90	250	μs	$R_L = 12\ \Omega$ $V_{bb} = 13.5\text{ V}$
5.1.16	Turn-off time to 10% V_{bb}	t_{OFF}	–	100	250	μs	$R_L = 12\ \Omega$ $V_{bb} = 13.5\text{ V}$

Block Description and Electrical Characteristics

$V_{bb} = 9\text{ V to }16\text{ V}$, $T_j = -40\text{ °C to }+150\text{ °C}$ (unless otherwise specified)
typical values: $V_{bb} = 13.5\text{ V}$, $T_j = 25\text{ °C}$

Pos.	Parameter	Symbol	Limit Values			Unit	Test Conditions
			min.	typ.	max.		
5.1.17	slew rate 10% to 30% V_{bb}	dV/dt_{ON}	0.1	0.25	0.45	V/ μ s	$R_L = 12\ \Omega$ $V_{bb} = 13.5\text{ V}$
5.1.18	slew rate 70% to 40% V_{bb}	$-dV/dt_{OFF}$	0.1	0.25	0.45	V/ μ s	$R_L = 12\ \Omega$ $V_{bb} = 13.5\text{ V}$

- 1) Device mounted on PCB (50 mm x 50 mm x 1.5 mm epoxy, FR4) with 6 cm² copper heatsinking area (one layer, 70 μ m thick) for V_{bb} connection. PCB is vertical without blown air.
- 2) Not subject to production test, parameters are calculated from $R_{DS(ON)}$ and R_{th}
- 3) Not subject to production test, specified by design

*Note: Characteristics show the deviation of parameter at the given supply voltage and junction temperature.
Typical values show the typical parameters expected from manufacturing.*

5.2 Thermal Resistance

Pos.	Parameter	Symbol	Limit Values			Unit	Conditions
			Min.	Typ.	Max.		
5.2.1	Junction to Case ¹⁾	R_{thJC}			1.8	K/W	—
5.2.2	Junction to Ambient ¹⁾ one channel on all channels on	R_{thJA}	— —	40 33	— —	K/W	2)

- 1) Not subject to production test, specified by design.
- 2) EIA/JESD 52_2, FR4, 80 x 80 x 1.5 mm; 35 μ Cu, 5 μ Sn; 300 mm²

6 Protection Functions

The device provides embedded protective functions. Integrated protection functions are designed to prevent IC destruction under fault conditions described in the data sheet. Fault conditions are considered as “outside” normal operating range. Protection functions are neither designed for continuous nor repetitive operation.

6.1 Over Load Protection

The load current I_{OUT} is limited by the device itself in case of over load or short circuit to ground. There are two steps of current limitation. They can be selected by the CLA pin, but are additionally selected automatically depending on the voltage V_{DS} across the power DMOS. Please note that the voltage at the OUT pin is $V_{bb} - V_{DS}$. Please refer to following figure for details.

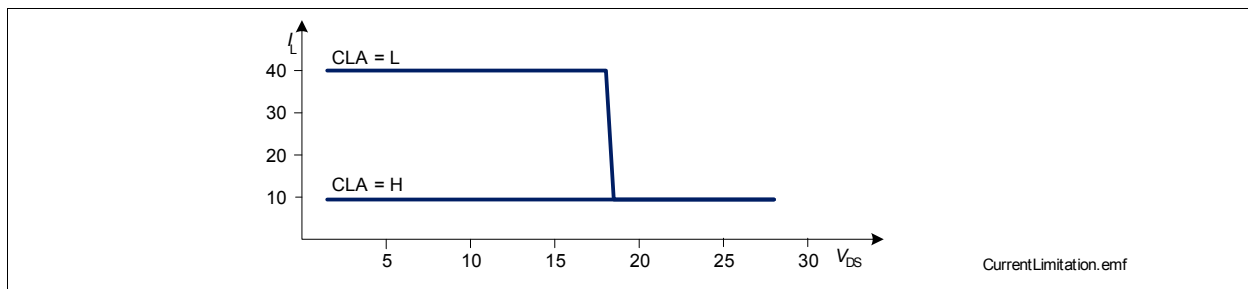

Figure 10 Current Limitation (minimum values)

Current limitation is realized by increasing the resistance of the device which leads to rapid temperature rise inside. A temperature sensor for each channel causes an overheated channel to switch off to prevent destruction. After cooling down with thermal hysteresis, the channel switches on again. Please refer to [Figure 11](#) for details.

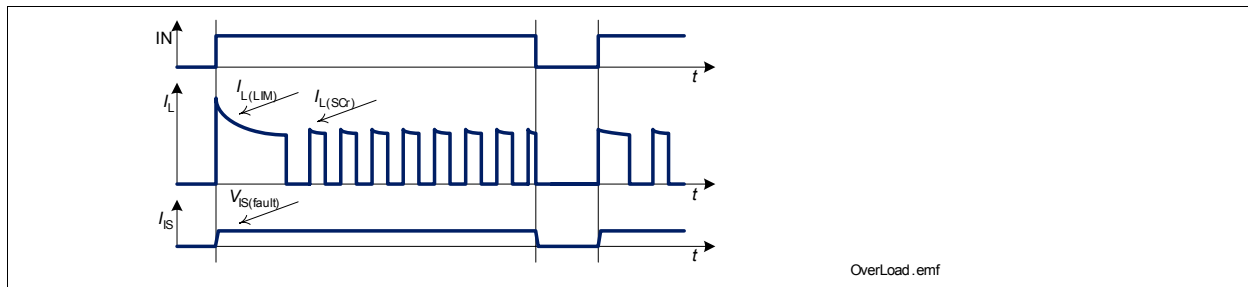

Figure 11 Shut Down by Over Temperature

The CLA pin circuit is designed equal to the input pin. Please refer to [Figure 5](#) for details. Please note that the thresholds for high and low state differ between IN and CLA.

6.2 Reverse Polarity Protection

In case of reverse polarity, the intrinsic body diode causes power dissipation. Use following formula for estimation of total power dissipation $P_{\text{diss(rev)}}$ in reverse polarity mode.

$$P_{\text{diss(rev)}} = \sum_{\text{all channels}} (V_{\text{DS(rev)}} I_{\text{L}})$$

The reverse current through the power transistors has to be limited by the connected loads. The reverse current through the ground connection has to be limited either by a resistor or by a pair of resistor and diode. The current through sense pins IS1 and IS2 has to be limited (please refer to maximum ratings on [Page 8](#)). The temperature protection is not active during reverse polarity.

6.3 Over Voltage Protection

In addition to the output clamp for inductive loads as described in [Section 5.1.3](#), there is a clamp mechanism for over voltage protection. The current through the ground connection has to be limited e.g. by a resistor.

As shown in [Figure 12](#), in case of supply voltages greater than $V_{\text{bb(AZ)}}$, the power transistor opens and the voltage across logic part is clamped. As a result, the ground potential rises to $V_{\text{bb}} - V_{\text{bb(AZ)}}$. Due to the ESD zener diodes, the potential at pin IN1, IN2 and CLA rises almost to that potential, depending on the impedance of the connected circuitry.

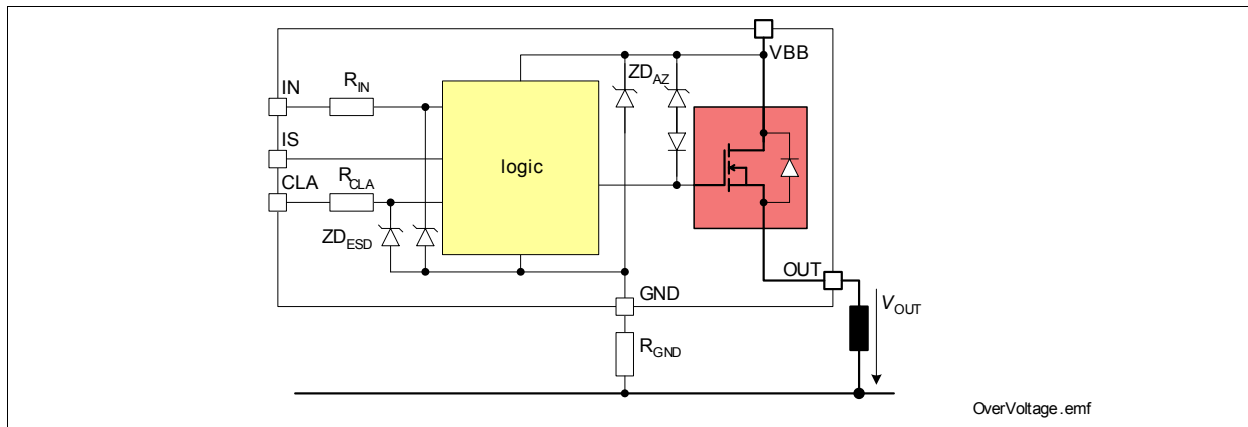

Figure 12 Over Voltage Protection

6.4 Loss of Ground Protection

In case of complete loss of the device ground connections, but connected load ground, the BTS5242-2L securely changes to or stays in off state.

6.5 Electrical Characteristics

$V_{bb} = 9\text{ V to }16\text{ V}$, $T_j = -40\text{ °C to }+150\text{ °C}$ (unless otherwise specified)

typical values: $V_{bb} = 13.5\text{ V}$, $T_j = 25\text{ °C}$

Pos.	Parameter	Symbol	Limit Values			Unit	Test Conditions
			min.	typ.	max.		
Over Load Protection							
6.5.1	Load current limitation	$I_{L(LIM)}$	40 7	50 11	60 14	A	$V_{DS} = 5\text{ V}$ CLA = 2 V CLA = 4 V
6.5.2	Repetitive short circuit current limitation	$I_{L(SCR)}$	– –	40 7	– –	A	$T_j = T_{j(SC)}^{1)}$ CLA = 0 V CLA = 5 V
6.5.3	Initial short circuit shut down time	$t_{OFF(SC)}$	– –	0.8 4	– –	ms	$T_{jStart} = 25\text{ °C}^{1)}$ CLA = 0 V CLA = 5 V
6.5.4	Thermal shut down temperature	$T_{j(SC)}$	150	170 ¹⁾	–	°C	
6.5.5	Thermal hysteresis	ΔT_j	–	10	–	K	– ¹⁾
Reverse Battery							
6.5.6	Drain-Source diode voltage ($V_{OUT} > V_{bb}$)	$-V_{DS(rev)}$	–	–	900	mV	$I_L = -5\text{ A}$ $T_j = 150\text{ °C}$
Over Voltage							
6.5.7	Over voltage protection	$V_{bb(AZ)}$	41	47	52	V	$I_{bb} = 40\text{ mA}$
Loss of GND							
6.5.8	Output current while GND disconnected	$I_{L(GND)}$	–	–	2	mA	$I_{IN} = 0^{1) 2)}$ $I_{GND} = 0$ $I_{IS} = 0$
Current Limit Adjust (CLA)							
6.5.9	Input resistance for pin CLA	R_{CLA}	2.0	3.5	5.5	kΩ	
6.5.10	L-input level for pin CLA	$V_{CLA(L)}$	-0.3	–	2.0	V	
6.5.11	H-input level for pin CLA	$V_{CLA(H)}$	4.0	–	–	V	
6.5.12	L-input current for pin CLA	$I_{CLA(L)}$	3	–	40	μA	$V_{CLA} = 0.4\text{ V}$
6.5.13	H-input current for pin CLA	$I_{CLA(H)}$	20	50	90	μA	$V_{CLA} = 5\text{ V}$

1) Not subject to production test, specified by design

2) Pins not connected

7 Diagnosis

For diagnosis purpose, the BTS5242-2L provides an IntelliSense signal at pins IS1 and IS2. This means in detail, the current sense signal I_{IS} , a proportional signal to the load current (ratio $k_{ILIS} = I_L / I_{IS}$), is provided as long as no failure mode (see [Table 1](#)) occurs. In case of a failure mode, the voltage $V_{IS(fault)}$ is fed to the diagnosis pin.

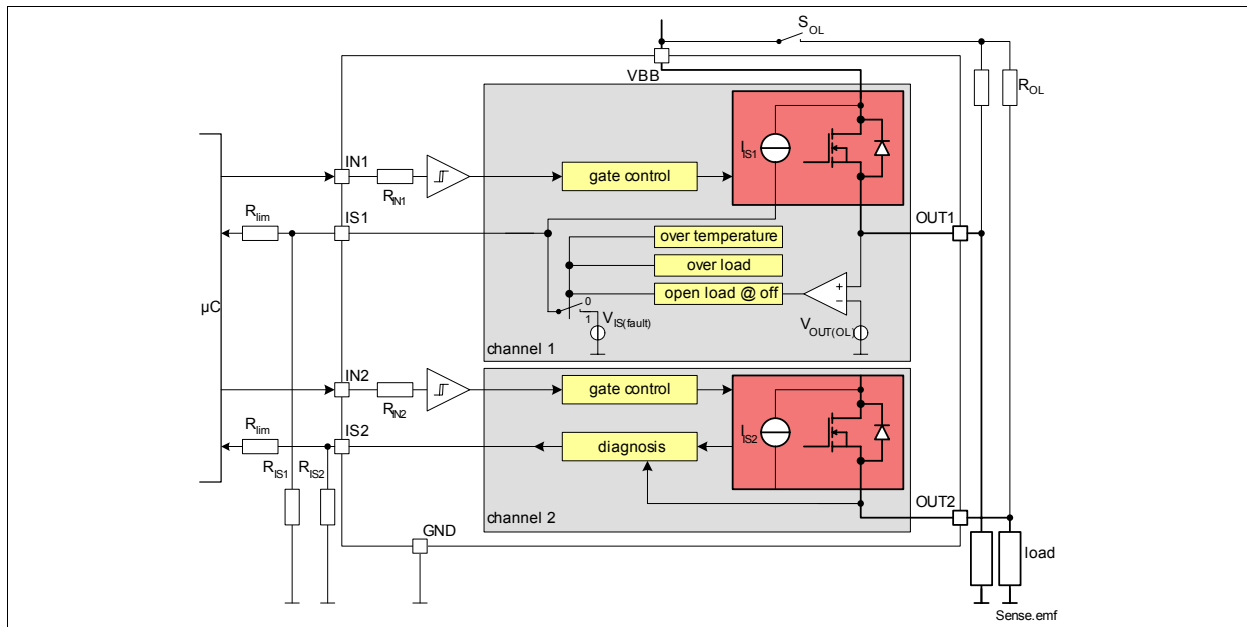

Figure 13 Block Diagram: Diagnosis

Table 1 Truth Table

Operation Mode	Input Level	Output Level	Diagnostic Output
Normal Operation (OFF)	L	Z	Z
Short Circuit to GND		Z	Z
Over Temperature		Z	Z
Short Circuit to V_{bb}		V_{bb}	$V_{IS} = V_{IS(fault)}$
Open Load		$< V_{OUT(OL)}$ $> V_{OUT(OL)}$	Z $V_{IS} = V_{IS(fault)}$
Normal Operation (ON)	H	$\sim V_{bb}$	$I_{IS} = I_L / k_{ILIS}$
Current Limitation		$< V_{bb}$	$V_{IS} = V_{IS(fault)}$
Short Circuit to GND		$\sim GND$	$V_{IS} = V_{IS(fault)}$
Over Temperature		Z	$V_{IS} = V_{IS(fault)}$
Short Circuit to V_{bb}		V_{bb}	$I_{IS} < I_L / k_{ILIS}$
Open Load		$\sim V_{bb}$	Z

L = Low Level, H = High Level, Z = high impedance, potential depends on external circuit

7.1 ON-State Diagnosis

The standard diagnosis signal is a current sense signal proportional to the load current. The accuracy of the ratio ($k_{ILIS} = I_L / I_{IS}$) depends on the temperature. Please refer to [Figure 14](#) for details. Usually a resistor R_{IS} is connected to the current sense pin. It is recommended to use sense resistors $R_{IS} > 500 \Omega$. A typical value is 4.7 k Ω

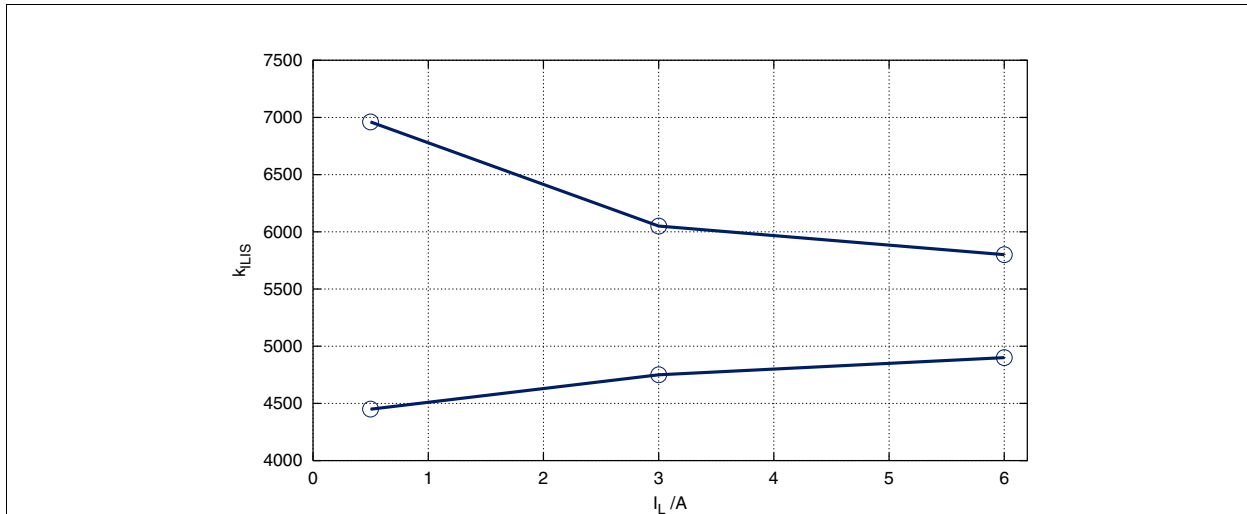

Figure 14 Current sense ratio k_{ILIS} ¹⁾

Details about timings between the diagnosis signal I_{IS} and the output voltage V_{OUT} and the load current I_L in ON-state can be found in [Figure 15](#).

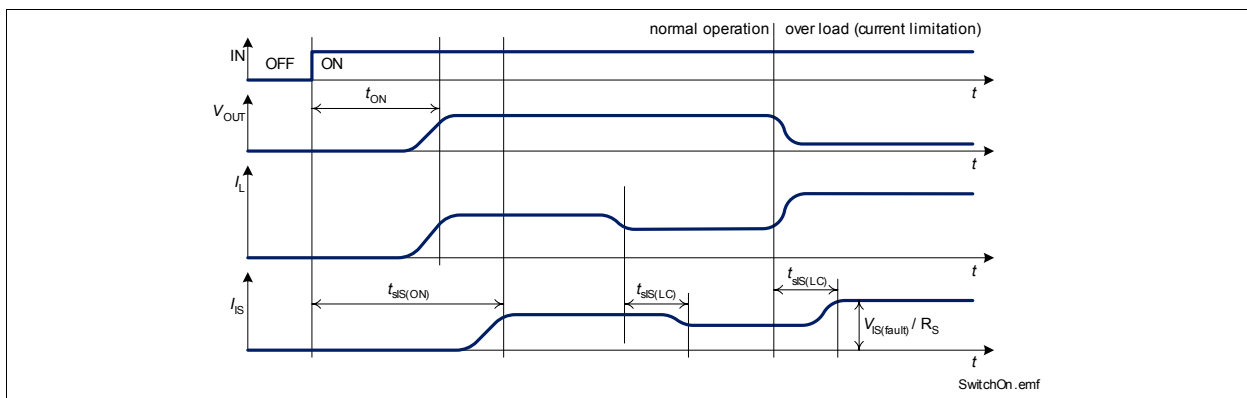

Figure 15 Timing of Diagnosis Signal in ON-state

In case of over-current as well as over-temperature, the voltage $V_{IS(fault)}$ is fed to the diagnosis pins as long as the according input pin is high. This means, even when the device keeps switching on and off in over-load condition, the failure signal is constantly available. Please refer to [Figure 16](#) for details.

1) The curves show the behavior based on characterization data. The marked points are guaranteed in this Data Sheet in [Section 7.3](#) (Position [7.3.7](#)).

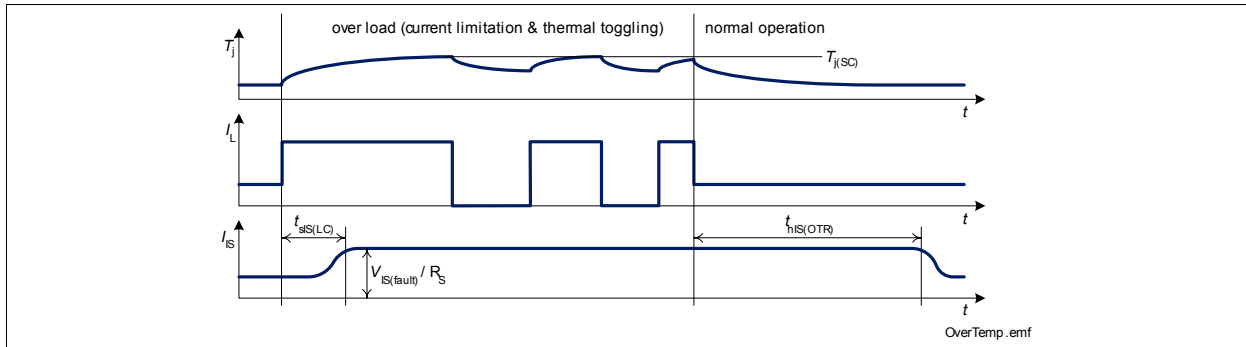

Figure 16 Timing of Diagnosis Signal in Over Load Condition

7.2 OFF-State Diagnosis

Details about timings between the diagnosis signal I_{IS} and the output voltage V_{OUT} and the load current I_L in OFF-state can be found in [Figure 17](#).

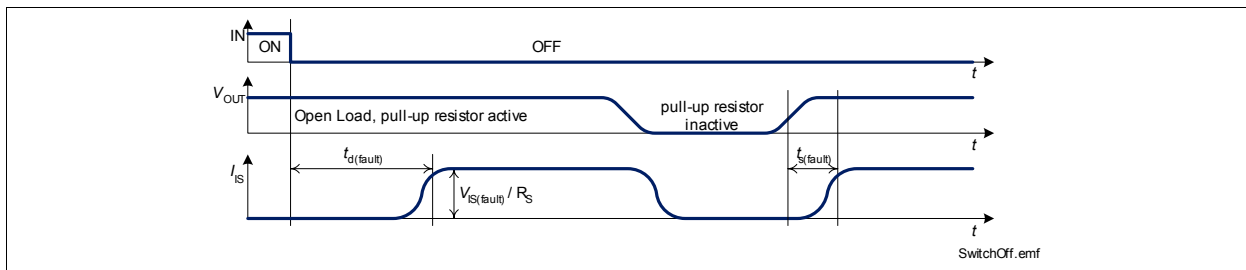

Figure 17 Timing of Diagnosis Signal in OFF-state

For open load diagnosis in off-state an external output pull-up resistor (R_{OL}) is recommended. For calculation of pull-up resistor, the leakage currents and the open load threshold voltage $V_{OUT(OL)}$ has to be taken into account. Depending on the application, an additional pull down resistor at the output might be necessary.

$$R_{OL} = \frac{V_{bb(min)} - V_{OUT(OL,max)}}{I_{leakage}}$$

$I_{leakage}$ defines the leakage current in the complete system including $I_{L(OL)}$ and external leakages e.g. due to humidity. $V_{bb(min)}$ is the minimum supply voltage at which the open load diagnosis in off-state must be ensured.

To reduce the stand-by current of the system, an open load resistor switch (S_{OL}) is recommended. The stand-by current of the BTS5242-2L is minimized, when both input pins (IN1 and IN2) are on low level or left open and $V_{OUT} < V_{OUT(OL)}$. In case of open load in off state ($V_{OUT} > V_{OUT(OL)}$ and $V_{IN} = 0$ V), the fault voltage $V_{IS(fault)}$ drives a current through the sense resistor, which causes an increase in supply current. To reduce the stand-by current to a minimum, the open load condition needs to be suppressed.

The resistors R_{lim} are recommended to limit the current through the sense pins IS1 and IS2 in case of reverse polarity and over voltage.

7.3 Electrical Characteristics

$V_{bb} = 9\text{ V to }16\text{ V}$, $T_j = -40\text{ °C to }+150\text{ °C}$ (unless otherwise specified)

typical values: $V_{bb} = 13.5\text{ V}$, $T_j = 25\text{ °C}$

Pos.	Parameter	Symbol	Limit Values			Unit	Test Conditions
			min.	typ.	max.		
Open Load at OFF state							
7.3.1	Open load detection threshold voltage	$V_{OUT(OL)}$	2.0	3.2	4.4	V	
7.3.2	Leakage current into OUT	$-I_{L(OL)}$	–	–	1	μA	$V_{OUT} = 5\text{ V}$
7.3.3	Sense signal in case of open load	$V_{IS(fault)}$	5.0	6.2	8	V	$V_{IN} = 0\text{ V}$ $V_{OUT} > V_{OUT(OL)}$ $I_{IS} = 1\text{ mA}$
7.3.4	Sense signal current limitation	$I_{IS(LIM)}$	4	–	–	mA	$V_{IS} = 0\text{ V}$ $V_{IN} = 0\text{ V}$ $V_{OUT} > V_{OUT(OL)}$
7.3.5	Sense signal invalid after negative input slope	$t_{d(fault)}$	–	–	1.2	ms	$V_{IN} = 5\text{ V to }0\text{ V}$ $V_{OUT} > V_{OUT(OL)}$
7.3.6	Fault signal settling time	$t_{s(fault)}$	–	–	200	μs	$V_{IN} = 0\text{ V}^{1)}$ $V_{OUT} = 0\text{ V to } > V_{OUT(OL)}$ $I_{IS} = 1\text{ mA}$

Load Current Sense

7.3.7	Current sense ratio	k_{ILIS}					$V_{IN} = 5\text{ V}$
		$I_L = 0.5\text{ A}$	4450	5800	6960		
		$I_L = 3.0\text{ A}$	4750	5400	6050		
		$I_L = 6.0\text{ A}$	4900	5350	5800		
7.3.8	Current sense voltage limitation	$V_{IS(LIM)}$	5.4	6.5	7.5	V	$I_L = 5\text{ A}$
7.3.9	Current sense leakage/offset current	$I_{IS(LH)}$	–	–	5	μA	$V_{IN} = 5\text{ V}$ $I_L = 0\text{ A}$
7.3.10	Current sense settling time to I_{IS} static $\pm 10\%$ after positive input slope	$t_{sIS(ON)}$	–	–	400	μs	$V_{IN} = 0\text{ V to }5\text{ V}$ $I_L = 5\text{ A}^{1)}$
7.3.11	Current sense settling time to I_{IS} static $\pm 10%$ after change of load current	$t_{sIS(LC)}$	–	–	300	μs	$V_{IN} = 5\text{ V}$ $I_L = 3\text{ A to }5\text{ A}^{1)}$
7.3.12	Fault signal hold time after thermal restart	$t_{HIS(OTR)}$	–	–	1.2	ms	¹⁾

1) Not subject to production test, specified by design

8 Package Outlines BTS5242-2L

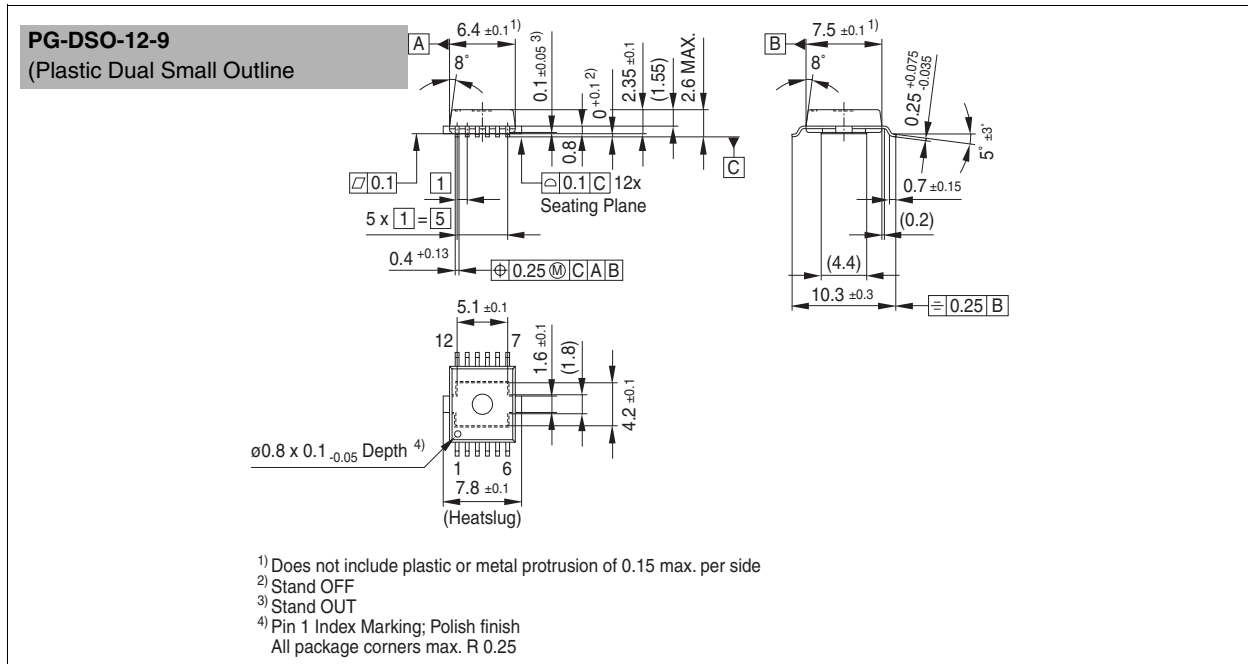

Figure 18 PG-DSO-12-9

Green Product (RoHS compliant)

To meet the world-wide customer requirements for environmentally friendly products and to be compliant with government regulations the device is available as a green product. Green products are RoHS-Compliant (i.e Pb-free finish on leads and suitable for Pb-free soldering according to IPC/JEDEC J-STD-020).

For further information on alternative packages, please visit our website:
<http://www.infineon.com/packages>.

Dimensions in mm

9 Revision History

Revision	Date	Changes
Rev 1.2	09-01-2008	Modification of the Figure 9
Rev.1.1	06-29-2007	<p>all pages: added new Infineon logo Creation of the green data sheet. First page: Adding the green logo and the AEC qualified Adding the bullet AEC qualified and the RoHS compliant features Package page Modification of the package to be green.</p> <p>page 8: table max. ratings: 4.1.7 parameter changed from 319 mJ to 130 mJ added test conditions $V_{bb} = 12V$ note 4: added see figure 8</p> <p>page 12: changed figure 9</p> <p>page 13: 5.1.2 added Test condition $I_L = 5 A$ 5.1.7 parameter changed from -17 to -12V to -24 to -17V</p> <p>page 20: add paragraph: Depending on the application, an additional pull down resistor at the output might be necessary.</p>
Rev.1.0	08-10-2004	initial version

Edition 2008-09-01

**Published by
Infineon Technologies AG
81726 Munich, Germany**

**© 9/1/08 Infineon Technologies AG
All Rights Reserved.**

Legal Disclaimer

The information given in this document shall in no event be regarded as a guarantee of conditions or characteristics. With respect to any examples or hints given herein, any typical values stated herein and/or any information regarding the application of the device, Infineon Technologies hereby disclaims any and all warranties and liabilities of any kind, including without limitation, warranties of non-infringement of intellectual property rights of any third party.

Information

For further information on technology, delivery terms and conditions and prices, please contact the nearest Infineon Technologies Office (www.infineon.com).

Warnings

Due to technical requirements, components may contain dangerous substances. For information on the types in question, please contact the nearest Infineon Technologies Office.

Infineon Technologies components may be used in life-support devices or systems only with the express written approval of Infineon Technologies, if a failure of such components can reasonably be expected to cause the failure of that life-support device or system or to affect the safety or effectiveness of that device or system. Life support devices or systems are intended to be implanted in the human body or to support and/or maintain and sustain and/or protect human life. If they fail, it is reasonable to assume that the health of the user or other persons may be endangered.