

Quad channel high side driver for automotive applications

Features

Max transient supply voltage	V_{CC}	41V
Operating voltage range	V_{CC}	4.5 to 36 V
Max on-state resistance (per ch.)	R_{ON}	160 m Ω
Current limitation (typ)	I_{LIMH}	5.4 A
Off-state supply current	I_S	2 μ A ⁽¹⁾

1. Typical value with all loads connected

■ General features

- Inrush current active management by power limitation
- Very low standby current
- 3.0 V CMOS compatible input
- Optimized electromagnetic emission
- Very low electromagnetic susceptibility
- In compliance with the 2002/95/EC European directive

■ Diagnostic functions

- Open drain status output
- On-state open-load detection
- Off-state open-load detection
- Thermal shutdown indication

■ Protection

- Undervoltage shutdown
- Overvoltage clamp
- Output stuck to V_{CC} detection
- Load current limitation
- Self limiting of fast thermal transients
- Protection against loss of ground and loss of V_{CC}
- Thermal shut down
- Reverse battery protection (see [Application schematic on page 18](#))

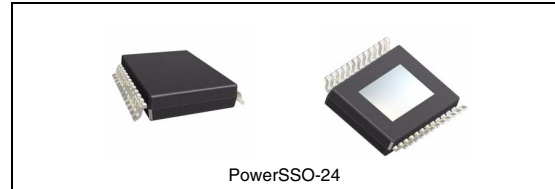

- Electrostatic discharge protection

Applications

- All types of resistive, inductive and capacitive loads

Description

The VNQ5160K-E is a monolithic device made using STMicroelectronics VIPower™ M0-5 technology. It is intended for driving resistive or inductive loads with one side connected to ground. Active V_{CC} pin voltage clamp protects the device against low energy spikes (see ISO7637 transient compatibility table).

The device detects open-load condition in both on and off states, when STAT_DIS is left open or driven low. Output shorted to V_{CC} is detected in the off-state. When STAT_DIS is driven high, the STATUS pin is in a high impedance condition.

Output current limitation protects the device in overload condition. In the case of long duration overload, the device limits the dissipated power to a safe level up to thermal shutdown intervention.

Thermal shutdown with automatic restart allows the device to recover normal operation as soon as a fault condition disappears.

Table 1. Device summary

Package	Order codes	
	Tube	Tape and reel
PowerSSO-24	VNQ5160K-E	VNQ5160KTR-E

Contents

1	Block diagram and pin configuration	5
2	Electrical specifications	7
2.1	Absolute maximum ratings	7
2.2	Thermal data	8
2.3	Electrical characteristics	8
2.4	Electrical characteristics curves	14
3	Application information	18
3.1	GND protection network against reverse battery	18
3.1.1	Solution 1: resistor in the ground line (RGND only).	18
3.1.2	Solution 2: a diode (DGND) in the ground line.	19
3.2	Load dump protection	19
3.3	Microcontroller I/Os protection	19
3.4	Open-load detection in off-state	19
3.5	Maximum demagnetization energy (VCC = 13.5V)	22
4	Package and PC board thermal data	23
4.1	PowerSSO-24 thermal data	23
5	Package and packing information	26
5.1	ECOPACK® packages	26
5.2	PowerSSO-24™ mechanical data	26
5.3	Packing information	28
6	Revision history	29

List of tables

Table 1.	Device summary	1
Table 2.	Pin functions	5
Table 3.	Suggested connections for unused and not connected pins	6
Table 4.	Absolute maximum ratings	7
Table 5.	Thermal data.	8
Table 6.	Power section	8
Table 7.	Switching ($V_{CC} = 13V$; $T_j = 25^{\circ}C$)	9
Table 8.	Status pin ($V_{SD}=0$)	9
Table 9.	Protection	9
Table 10.	Open-load detection	10
Table 11.	Logic input	10
Table 12.	Truth table.	12
Table 13.	Electrical transient requirements (part 1/3).	13
Table 14.	Electrical transient requirements (part 2/3).	13
Table 15.	Electrical transient requirements (part 3/3).	13
Table 16.	Thermal parameters	25
Table 17.	PowerSSO-24™ mechanical data	27
Table 20.	Document revision history	29

List of figures

Figure 1.	Block diagram	5
Figure 2.	Configuration diagram (top view)	6
Figure 3.	Current and voltage conventions	7
Figure 4.	Status timings	11
Figure 5.	Output voltage drop limitation	11
Figure 6.	Switching characteristics	12
Figure 7.	Off-state output current	14
Figure 8.	High level input current	14
Figure 9.	Input clamp voltage	14
Figure 10.	Input low level voltage	14
Figure 11.	Input high level voltage	14
Figure 12.	Input hysteresis voltage	14
Figure 13.	Status low output voltage	15
Figure 14.	Status leakage current	15
Figure 15.	On-state resistance vs T_{case}	15
Figure 16.	On-state resistance vs V_{CC}	15
Figure 17.	Status clamp voltage	15
Figure 18.	Open-load on-state detection threshold	15
Figure 19.	Open-load off-state voltage detection threshold	16
Figure 20.	Undervoltage shutdown	16
Figure 21.	Turn-on voltage slope	16
Figure 22.	I_{LIMH} vs T_{case}	16
Figure 23.	Turn-off voltage slope	16
Figure 24.	High-level STAT_DIS voltage	16
Figure 25.	STAT_DIS clamp voltage	17
Figure 26.	Low level STAT_DIS voltage	17
Figure 27.	Application schematic	18
Figure 28.	Open-load detection in off-state	20
Figure 29.	Waveforms	21
Figure 30.	Maximum turn-off current versus inductance (for each channel)	22
Figure 31.	PowerSSO-24 PC board	23
Figure 32.	$R_{thj-amb}$ vs PCB copper area in open box free air condition (one channel ON)	23
Figure 33.	PowerSSO-24 thermal impedance junction ambient single pulse (one channel on)	24
Figure 34.	Thermal fitting model of a double channel HSD in PowerSSO-24 ⁽¹⁾	24
Figure 35.	PowerSSO-24 TM package dimensions	26
Figure 36.	PowerSSO-24 tube shipment (no suffix)	28
Figure 37.	Tape and reel shipment (suffix "TR")	28

1 Block diagram and pin configuration

Figure 1. Block diagram

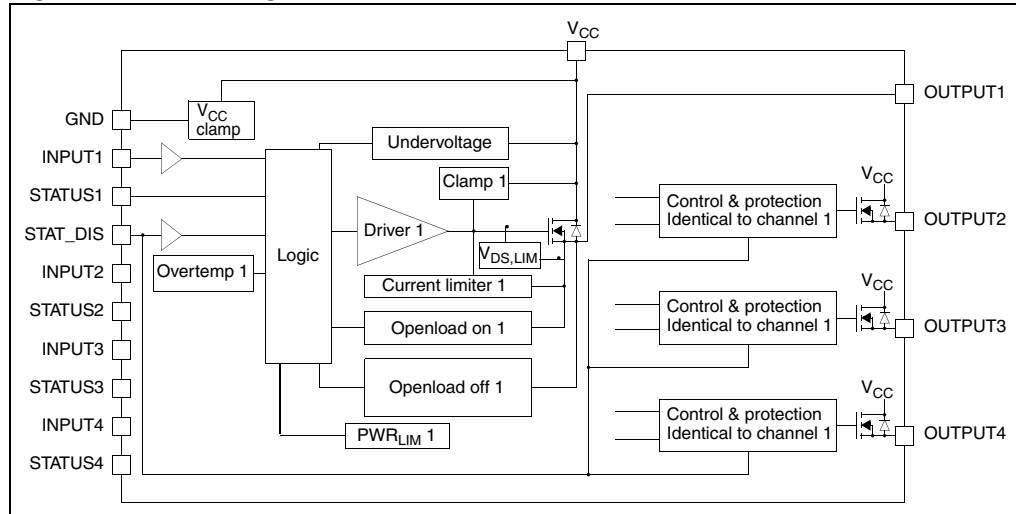

Table 2. Pin functions

Name	Function
V _{CC}	Battery connection
OUTPUTn	Power output
GND	Ground connection. Must be reverse battery protected by an external diode/resistor network
INPUTn	Voltage controlled input pin with hysteresis, CMOS compatible. Controls output switch state
STATUSn	Open drain digital diagnostic pin
STAT_DIS	Active high CMOS compatible pin, to disable the STATUS pin

Figure 2. Configuration diagram (top view)

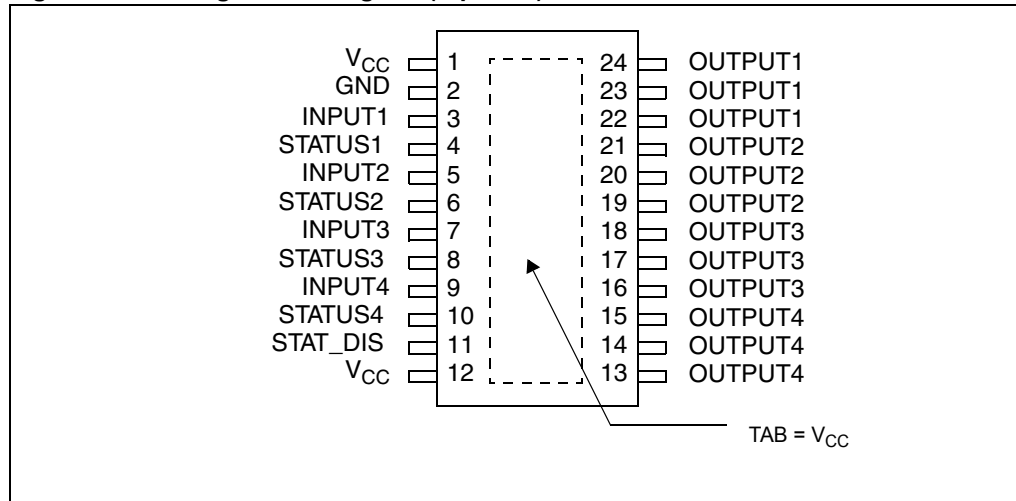

Table 3. Suggested connections for unused and not connected pins

Connection / Pin	Status	N.C.	Output	Input	STAT_DIS
Floating	X	X	X	X	X
To ground	N.R. ⁽¹⁾	X	N.R.	Through 10 kΩ resistor	Through 10 kΩ resistor

1. Not recommended

2 Electrical specifications

Figure 3. Current and voltage conventions

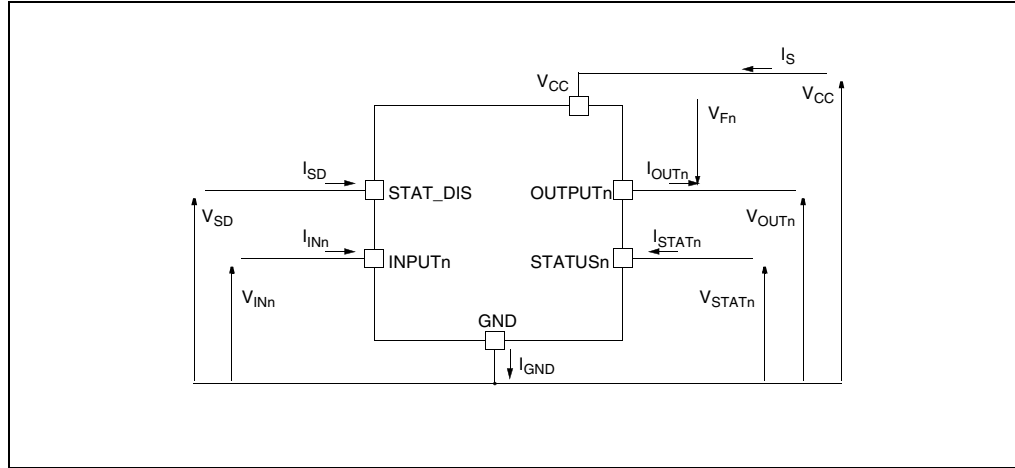

Note: $V_{Fn} = V_{OUTn} - V_{CCn}$ during reverse battery condition

2.1 Absolute maximum ratings

Table 4. Absolute maximum ratings

Symbol	Parameter	Value	Unit
V_{CC}	DC supply voltage	41	V
$-V_{CC}$	Reverse DC supply voltage	0.3	V
$-I_{GND}$	DC reverse ground pin current	200	mA
I_{OUT}	DC output current	Internally limited	A
$-I_{OUT}$	Reverse DC output current	6	A
I_{IN}	DC input current	+10 / -1	mA
I_{STAT}	DC status current	+10 / -1	mA
I_{STAT_DIS}	DC status disable current	+10 / -1	mA
E_{MAX}	Maximum switching energy (single pulse) ($L=12\text{mH}$; $R_L=0\Omega$; $V_{bat}=13.5\text{V}$; $T_{jstart}=150^\circ\text{C}$; $I_{OUT} = I_{limL}(\text{Typ.})$)	33	mJ
V_{ESD}	Electrostatic discharge (Human Body Model: $R=1.5\text{K}\Omega$; $C=100\text{pF}$)		
	– Input	4000	V
	– Status	4000	V
	– STAT_DIS	4000	V
	– Output	5000	V
	– V_{CC}	5000	V
V_{ESD}	Charge device model (CDM-AEC-Q100-011)	750	V

Table 4. Absolute maximum ratings (continued)

Symbol	Parameter	Value	Unit
T_j	Junction operating temperature	-40 to 150	°C
T_{stg}	Storage temperature	- 55 to 150	°C

2.2 Thermal data

Table 5. Thermal data

Symbol	Parameter	Max. value	Unit
$R_{thj-case}$	Thermal resistance junction-case (with one channel on)	8	°C/W
$R_{thj-amb}$	Thermal resistance junction-ambient	See Figure 32 .	°C/W

2.3 Electrical characteristics

8V < V_{CC} < 36V; -40°C < T_j < 150°C, unless otherwise specified

Table 6. Power section

Symbol	Parameter	Test conditions	Min.	Typ.	Max.	Unit
V_{CC}	Operating supply voltage		4.5	13	36	V
V_{USD}	Undervoltage shutdown			3.5	4.5	V
$V_{USDhyst}$	Undervoltage shutdown hysteresis			0.5		V
R_{ON}	On-state resistance ⁽¹⁾	$I_{OUT}=1A$; $T_j=25^\circ C$ $I_{OUT}=1A$; $T_j=150^\circ C$ $I_{OUT}=1A$; $V_{CC}=5V$; $T_j=25^\circ C$			160 320 210	mΩ mΩ mΩ
V_{clamp}	Clamp voltage	$I_S=20$ mA	41	46	52	V
I_S	Supply current	Off-state; $V_{CC}=13V$; $V_{IN}=V_{OUT}=0V$; $T_j=25^\circ C$ On-state; $V_{IN}=5V$; $V_{CC}=13V$; $I_{OUT}=0A$		2 ⁽²⁾ 8	5 ⁽²⁾ 14	μA mA
$I_{L(off1)}$	Off-state output current ⁽¹⁾	$V_{IN}=V_{OUT}=0V$; $V_{CC}=13V$; $T_j=25^\circ C$ $V_{IN}=V_{OUT}=0V$; $V_{CC}=13V$; $T_j=125^\circ C$	0 0	0.01	3 5	μA μA
$I_{L(off2)}$	Off-state output current ⁽¹⁾	$V_{IN}=0V$; $V_{OUT}=4V$	-75		0	μA
V_F	Output - V_{CC} diode voltage ⁽¹⁾	$-I_{OUT}=0.6A$; $T_j=150^\circ C$			0.7	V

1. For each channel.

2. PowerMOS leakage included.

Table 7. Switching ($V_{CC} = 13V$; $T_j = 25^\circ C$)

Symbol	Parameter	Test conditions	Min.	Typ.	Max.	Unit
$t_{d(on)}$	Turn-on delay time	$R_L=13\Omega$ (see Figure 6.)		15		μs
$t_{d(off)}$	Turn-off delay time	$R_L=13\Omega$ (see Figure 6.)		15		μs
$dV_{OUT}/dt_{(on)}$	Turn-on voltage slope	$R_L=13\Omega$		See Figure 6.		$V/\mu s$
$dV_{OUT}/dt_{(off)}$	Turn-off voltage slope	$R_L=13\Omega$		See Figure 6.		$V/\mu s$
W_{ON}	Switching energy losses during t_{won}	$R_L=13\Omega$ (see Figure 6.)		0.05		mJ
W_{OFF}	Switching energy losses during t_{woff}	$R_L=13\Omega$ (see Figure 6.)		0.03		mJ

Table 8. Status pin ($V_{SD}=0$)

Symbol	Parameter	Test conditions	Min	Typ	Max	Unit
V_{STAT}	Status low output voltage	$I_{STAT}= 1.6 \text{ mA}$, $V_{SD}=0V$			0.5	V
I_{LSTAT}	Status leakage current	Normal operation or $V_{SD}=5V$, $V_{STAT}= 5V$			10	μA
C_{STAT}	Status pin input capacitance	Normal operation or $V_{SD}=5V$, $V_{STAT}= 5V$			100	pF
V_{SCL}	Status clamp voltage	$I_{STAT}= 1mA$ $I_{STAT}= -1mA$	5.5	-0.7	7	V V

Table 9. Protection⁽¹⁾

Symbol	Parameter	Test conditions	Min.	Typ.	Max.	Unit
I_{limH}	DC Short circuit current	$V_{CC}=13V$ $5V < V_{CC} < 36V$	3.8	5.4	7.5 7.5	A A
I_{limL}	Short circuit current during thermal cycling	$V_{CC}=13V$ $T_R < T_j < T_{TSD}$		2		A
T_{TSD}	Shutdown temperature		150	175	200	$^\circ C$
T_R	Reset temperature		$T_{RS} + 1$	$T_{RS} + 5$		$^\circ C$
T_{RS}	Thermal reset of STATUS		135			$^\circ C$
T_{HYST}	Thermal hysteresis ($T_{TSD}-T_R$)			7		$^\circ C$
t_{SDL}	Status delay in overload conditions	$T_j > T_{TSD}$ (See Figure 4.)			20	μs

Table 9. Protection⁽¹⁾ (continued)

Symbol	Parameter	Test conditions	Min.	Typ.	Max.	Unit
V _{DEMAG}	Turn-off output voltage clamp	I _{OUT} =1A; V _{IN} =0; L=20mH	V _{CC} -41	V _{CC} -46	V _{CC} -52	V
V _{ON}	Output voltage drop limitation	I _{OUT} =0.03A (see Figure 5.) T _j = -40°C...+150°C		25		mV

1. To ensure long term reliability under heavy overload or short circuit conditions, protection and related diagnostic signals must be used together with a proper software strategy. If the device is subjected to abnormal conditions, this software must limit the duration and number of activation cycles

Table 10. Open-load detection

Symbol	Parameter	Test conditions	Min	Typ	Max	Unit
I _{OL}	Open-load on-state detection threshold	V _{IN} = 5V, 8V < V _{CC} < 18V	10	See Figure 18.	40	mA
t _{DOL(on)}	Open-load on-state detection delay	I _{OUT} = 0A, V _{CC} =13V (See Figure 4.)			200	μs
t _{POL}	Delay between INPUT falling edge and STATUS rising edge in Open-load condition	I _{OUT} = 0A (See Figure 4.)	200	500	1000	μs
V _{OL}	Open-load OFF-state voltage detection threshold	V _{IN} = 0V, 8V < V _{CC} < 16V	2	See Figure 19.	4	V
t _{DSTKON}	Output short circuit to V _{CC} detection delay at turn-off	(See Figure 4.)	180		t _{POL}	μs

Table 11. Logic input

Symbol	Parameter	Test conditions	Min.	Typ.	Max.	Unit
V _{IL}	Input low level				0.9	V
I _{IL}	Low level input current	V _{IN} = 0.9V	1			μA
V _{IH}	Input high level		2.1			V
I _{IH}	High level input current	V _{IN} = 2.1V			10	μA
V _{I(hyst)}	Input hysteresis voltage		0.25			V
V _{ICL}	Input clamp voltage	I _{IN} = 1mA I _{IN} = -1mA	5.5	-0.7	7	V
V _{SDL}	STAT_DIS low level voltage				0.9	V
I _{SDL}	Low level STAT_DIS current	V _{SD} =0.9V	1			μA
V _{SDH}	STAT_DIS high level voltage		2.1			V

Table 11. Logic input (continued)

Symbol	Parameter	Test conditions	Min.	Typ.	Max.	Unit
I_{SDH}	High level STAT_DIS current	$V_{SD}=2.1V$			10	μA
$V_{SD(hyst)}$	STAT_DIS hysteresis voltage		0.25			V
V_{SDCL}	STAT_DIS clamp voltage	$I_{SD}=1mA$ $I_{SD}=-1mA$	5.5	-0.7	7	V V

Figure 4. Status timings

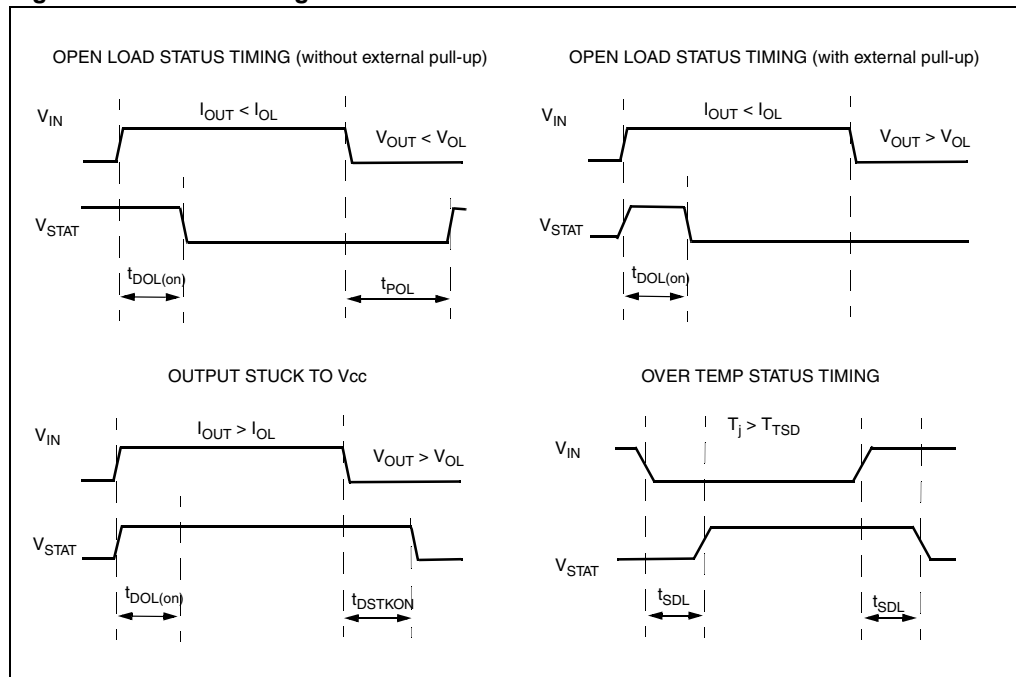

Figure 5. Output voltage drop limitation

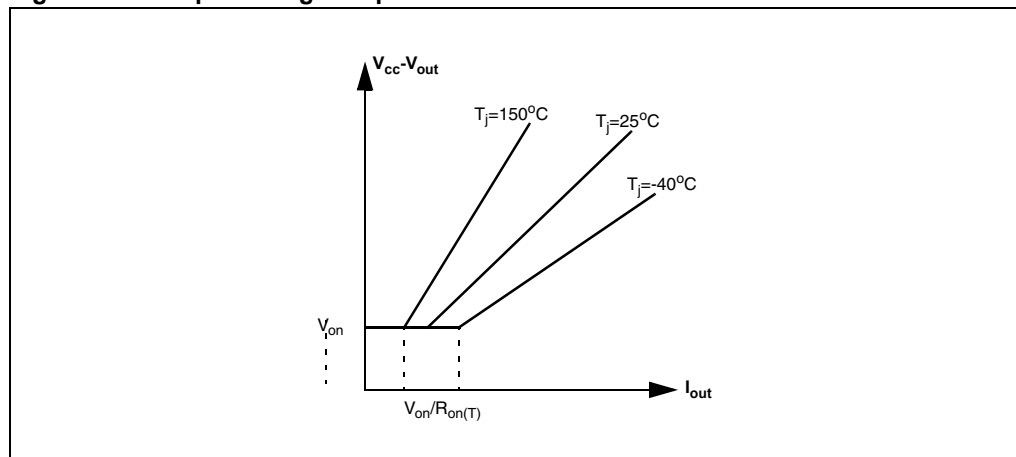

Table 12. Truth table

Conditions	INPUTn	OUTPUTn	STATUSn ($V_{SD}=0V$) ⁽¹⁾
Normal operation	L	L	H
	H	H	H
Current limitation	L	L	H
	H	X	H
Overtemperature	L	L	H
	H	L	L
Undervoltage	L	L	X
	H	L	X
Output voltage > V_{OL}	L	H	L ⁽²⁾
	H	H	H
Output current < I_{OL}	L	L	H ⁽³⁾
	H	H	L

1. If the V_{SD} is high, the STATUS pin is in a high impedance.
2. The STATUS pin is low with a delay equal to t_{DSTKON} after INPUT falling edge.
3. The STATUS pin becomes high with a delay equal to t_{POL} after INPUT falling edge.

Figure 6. Switching characteristics

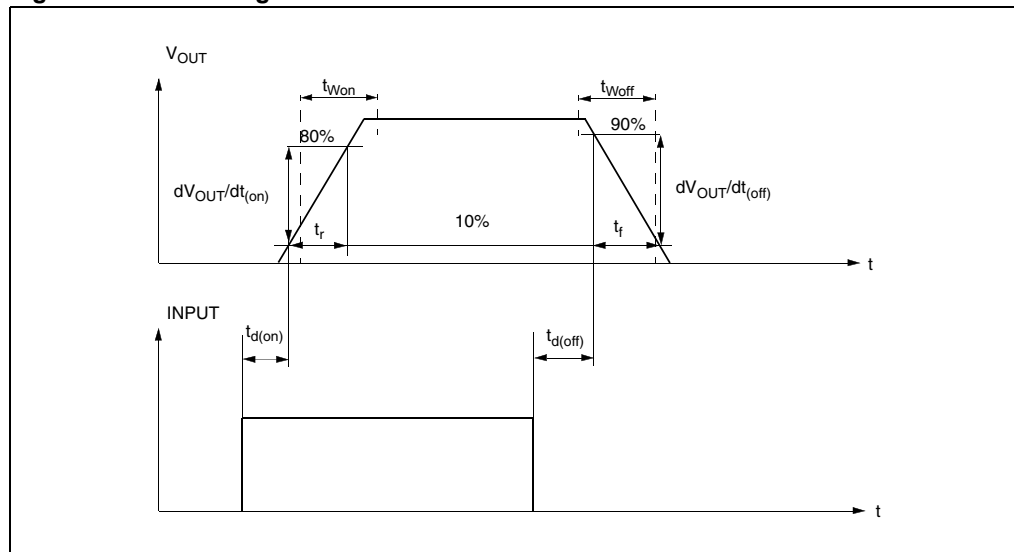

Table 13. Electrical transient requirements (part 1/3)

ISO 7637-2: 2004(E) Test pulse	Test levels ⁽¹⁾		Number of pulses or test times	Burst cycle/pulse repetition time		Delays and Impedance
	III	IV				
1	-75 V	-100 V	5000 pulses	0.5 s	5 s	2 ms, 10 Ω
2a	+37 V	+50 V	5000 pulses	0.2 s	5 s	50 μ s, 2 Ω
3a	-100 V	-150 V	1h	90 ms	100 ms	0.1 μ s, 50 Ω
3b	+75 V	+100 V	1h	90 ms	100 ms	0.1 μ s, 50 Ω
4	-6 V	-7 V	1 pulse			100 ms, 0.01 Ω
5b ⁽¹⁾	+65 V	+87 V	1 pulse			400 ms, 2 Ω

1. Valid in case of external load dump clamp: 40V maximum referred to ground.

Table 14. Electrical transient requirements (part 2/3)

ISO 7637-2: 2004(E) Test pulse	Test level results ⁽¹⁾	
	III	IV
1	C	C
2a	C	C
3a	C	C
3b	C	C
4	C	C
5b ⁽²⁾	C	C

1. The above test levels must be considered referred to Vcc = 13.5V except for pulse 5b

2. Valid in case of external load dump clamp: 40V maximum referred to ground.

Table 15. Electrical transient requirements (part 3/3)

Class	Contents
C	All functions of the device are performed as designed after exposure to disturbance.
E	One or more functions of the device are not performed as designed after exposure to disturbance and cannot be returned to proper operation without replacing the device.

2.4 Electrical characteristics curves

Figure 7. Off-state output current

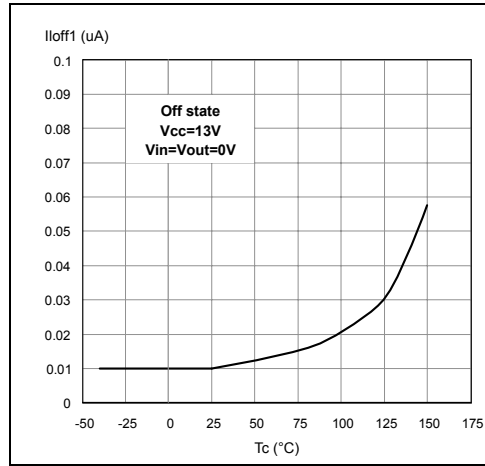

Figure 8. High level input current

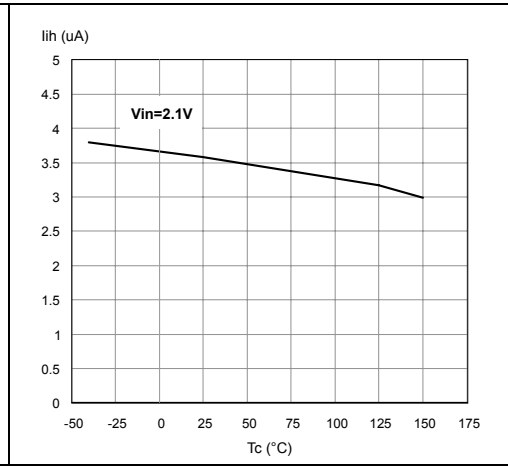

Figure 9. Input clamp voltage

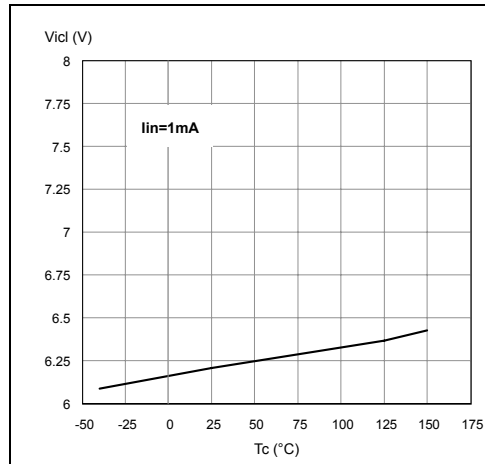

Figure 10. Input low level voltage

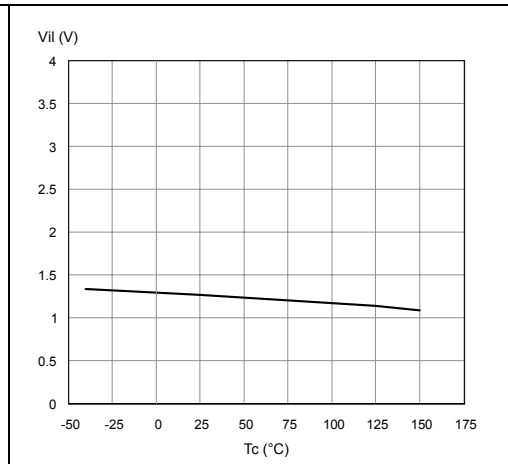

Figure 11. Input high level voltage

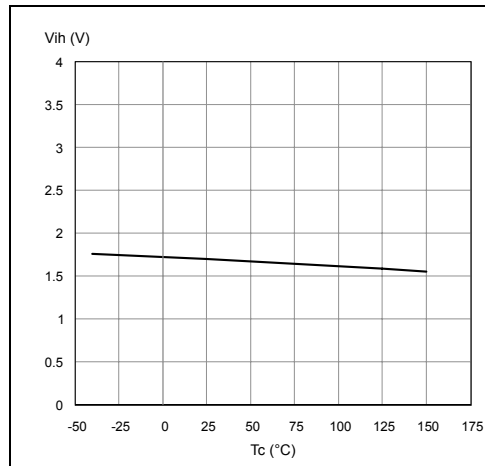

Figure 12. Input hysteresis voltage

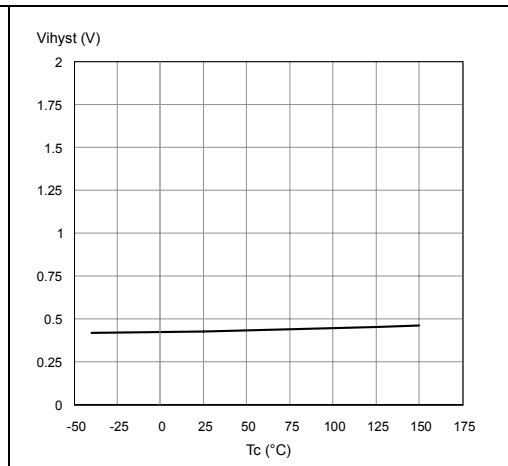

Figure 13. Status low output voltage

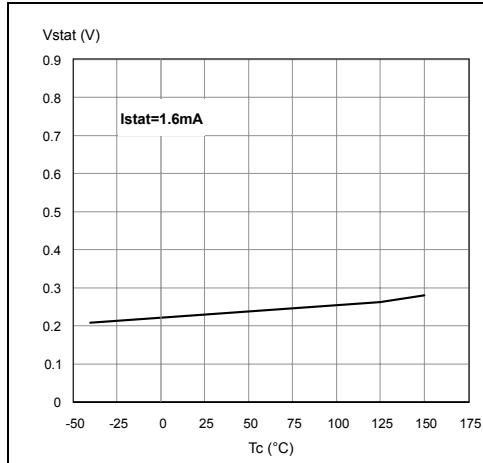

Figure 14. Status leakage current

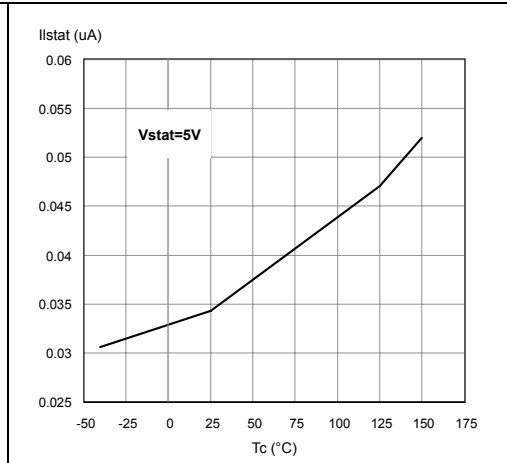

Figure 15. On-state resistance vs T_{case}

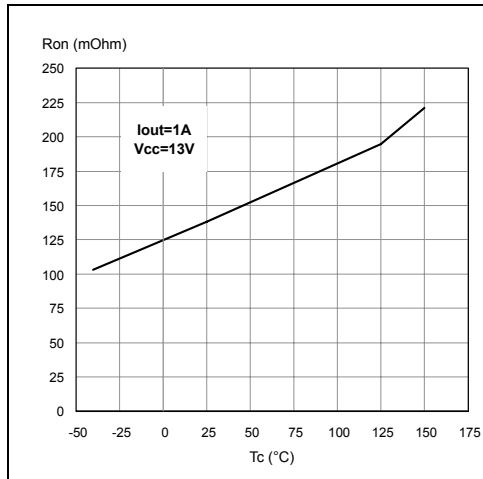

Figure 16. On-state resistance vs V_{CC}

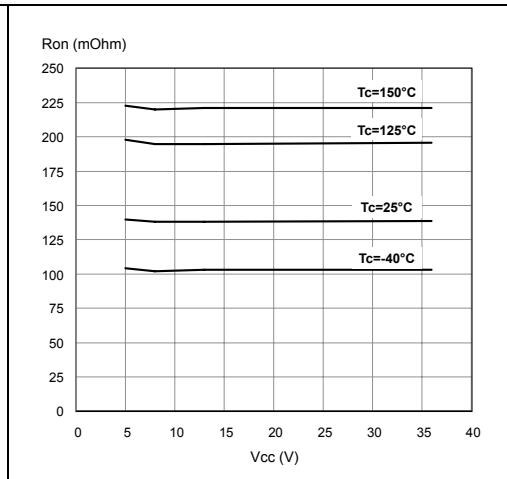

Figure 17. Status clamp voltage

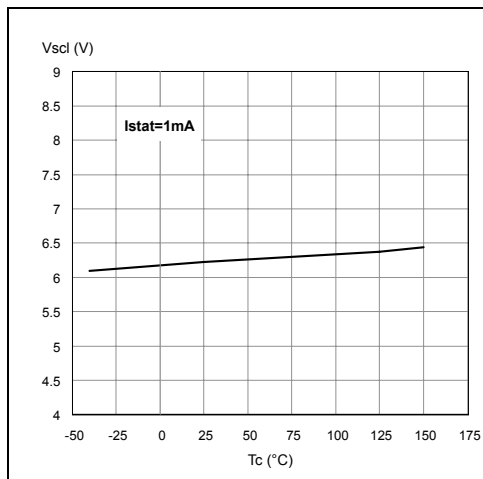

Figure 18. Open-load on-state detection threshold

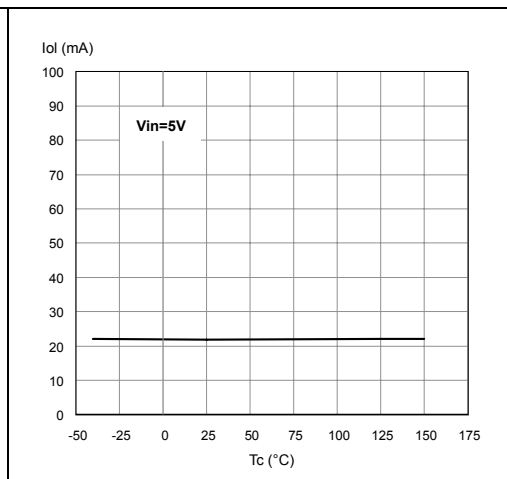

Figure 19. Open-load off-state voltage detection threshold

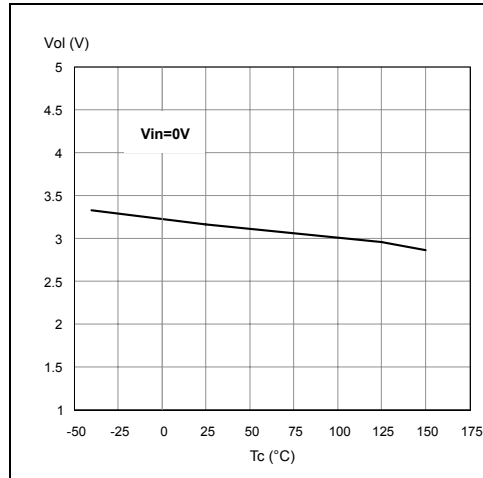

Figure 20. Undervoltage shutdown

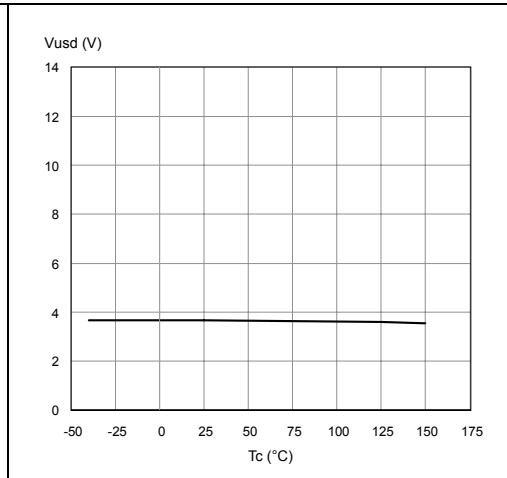

Figure 21. Turn-on voltage slope

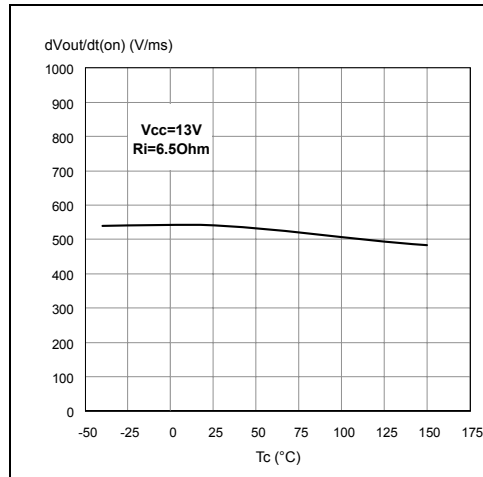

Figure 22. I_{LIMH} vs T_{case}

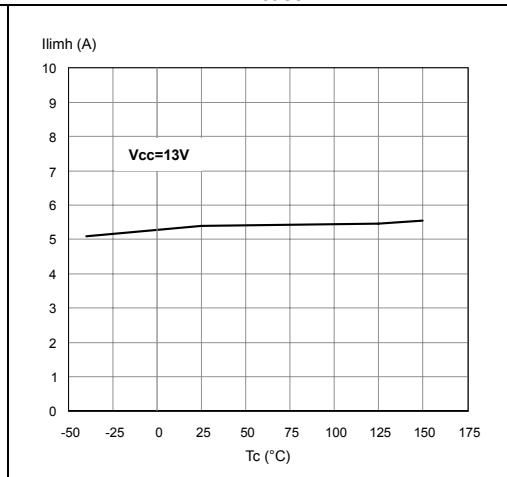

Figure 23. Turn-off voltage slope

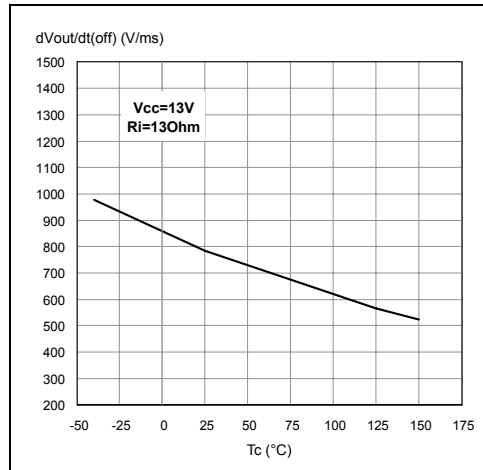

Figure 24. High-level STAT_DIS voltage

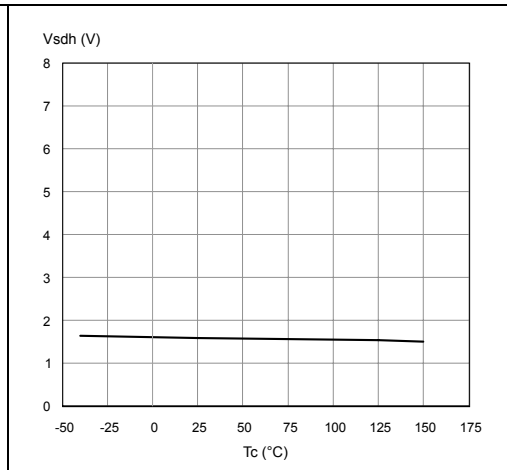

Figure 25. STAT_DIS clamp voltage

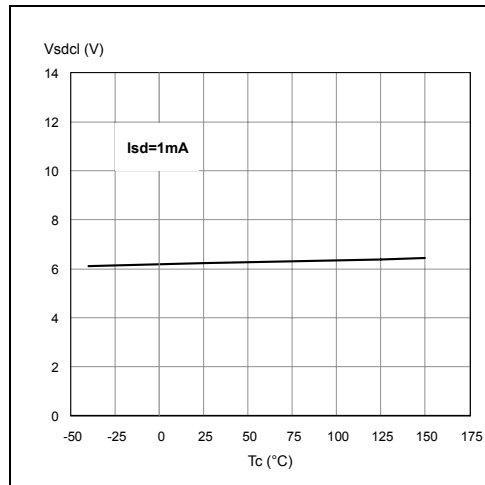
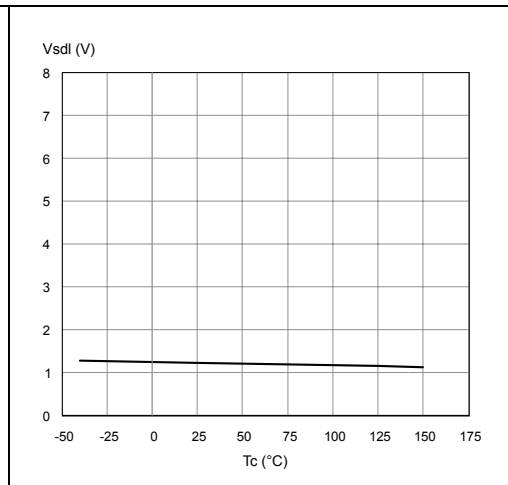
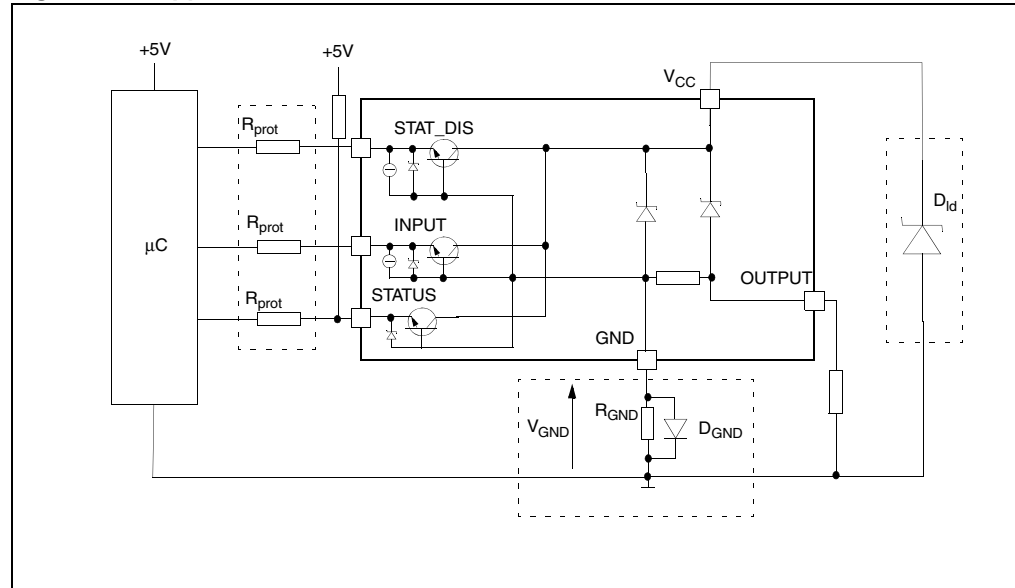

Figure 26. Low level STAT_DIS voltage



3 Application information

Figure 27. Application schematic



Note: Channels 2, 3 and 4 have the same internal circuit as channel 1.

3.1 GND protection network against reverse battery

3.1.1 Solution 1: resistor in the ground line (R_{GND} only).

This solution can be used with any type of load.

The following is an indication on how to dimension the R_{GND} resistor.

1. $R_{GND} \leq 600\text{mV} / (I_{S(on)max})$.
2. $R_{GND} \geq (-V_{CC}) / (-I_{GND})$

where $-I_{GND}$ is the DC reverse ground pin current and can be found in the absolute maximum rating section of the device datasheet.

Power dissipation in R_{GND} (when $V_{CC} < 0$: during reverse battery situations) is:

$$P_D = (-V_{CC})^2 / R_{GND}$$

This resistor can be shared amongst several different HSDs. Please note that the value of this resistor should be calculated with formula (1) where $I_{S(on)max}$ becomes the sum of the maximum on-state currents of the different devices.

Please note that if the microprocessor ground is not shared by the device ground then the R_{GND} will produce a shift ($I_{S(on)max} * R_{GND}$) in the input thresholds and the status output values. This shift will vary depending on how many devices are ON in the case of several high side drivers sharing the same R_{GND} .

If the calculated power dissipation leads to a large resistor or several devices have to share the same resistor then ST suggests that Solution 2 is used(see below).

3.1.2 Solution 2: a diode (D_{GND}) in the ground line.

A resistor ($R_{GND}=1k\Omega$) should be inserted in parallel with D_{GND} if the device drives an inductive load.

This small signal diode can be safely shared amongst several different HSDs. Also in this case, the presence of the ground network will produce a shift ($\sim 600mV$) in the input threshold and in the status output values if the microprocessor ground is not common with the device ground. This shift will not vary if more than one HSD shares the same diode/resistor network.

3.2 Load dump protection

D_{ld} is necessary (Voltage Transient Suppressor) if the load dump peak voltage exceeds to V_{CC} max DC rating. The same applies if the device is subject to transients on the V_{CC} line that are greater than the ones shown in the ISO T/R 7637/1 table.

3.3 Microcontroller I/Os protection

If a ground protection network is used and negative transients are present on the V_{CC} line, the control pins will be pulled negative. ST suggests the insertion of resistors (R_{prot}) in the lines to prevent the μC I/Os pins from latching up.

The values of these resistors are a compromise between the leakage current of μC and the current required by the HSD I/Os (input levels compatibility) with the latch-up limit of the μC I/Os.

$$-V_{CCpeak}/I_{latchup} \leq R_{prot} \leq (V_{OH\mu C} - V_{IH} - V_{GND}) / I_{IHmax}$$

Calculation example:

For $V_{CCpeak} = -100V$ and $I_{latchup} \geq 20mA$; $V_{OH\mu C} \geq 4.5V$

$$5k\Omega \leq R_{prot} \leq 65k\Omega$$

Recommended R_{prot} value is $10k\Omega$.

3.4 Open-load detection in off-state

Off-state open-load detection requires an external pull-up resistor (R_{PU}) connected between the OUTPUT pin and a positive supply voltage (V_{PU}) like the +5V line used to supply the microprocessor.

The external resistor has to be selected according to the following requirements:

1. No false open-load indication when load is connected: in this case we have to avoid V_{OUT} to be higher than V_{OLmin} ; this results in the following condition:

$$V_{OUT} = (V_{PU} / (R_L + R_{PU})) R_L < V_{OLmin}$$
2. No misdetection when the load is disconnected: in this case the V_{OUT} has to be higher than V_{OLmax} ; this results in the following condition:

$$R_{PU} < (V_{PU} - V_{OLmax}) / I_{L(off2)}$$

Because $I_{S(OFF)}$ may significantly increase if V_{OUT} is pulled high (up to several mA), the pull-up resistor R_{PU} should be connected to a supply that is switched OFF when the module is in standby.

The values of V_{OLmin} , V_{OLmax} and $I_{L(off2)}$ are available in the Electrical characteristics section.

Figure 28. Open-load detection in off-state

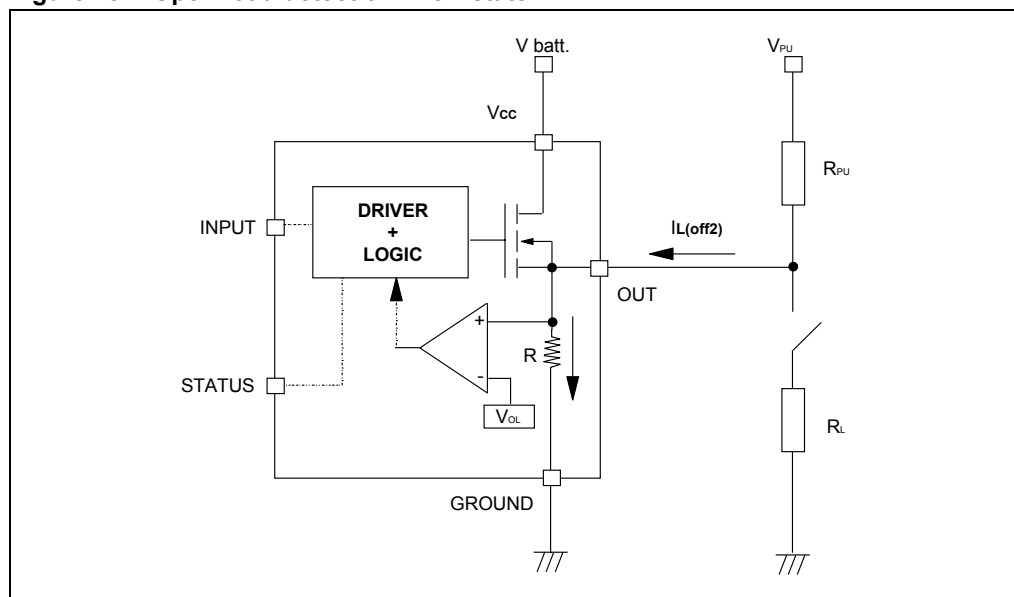
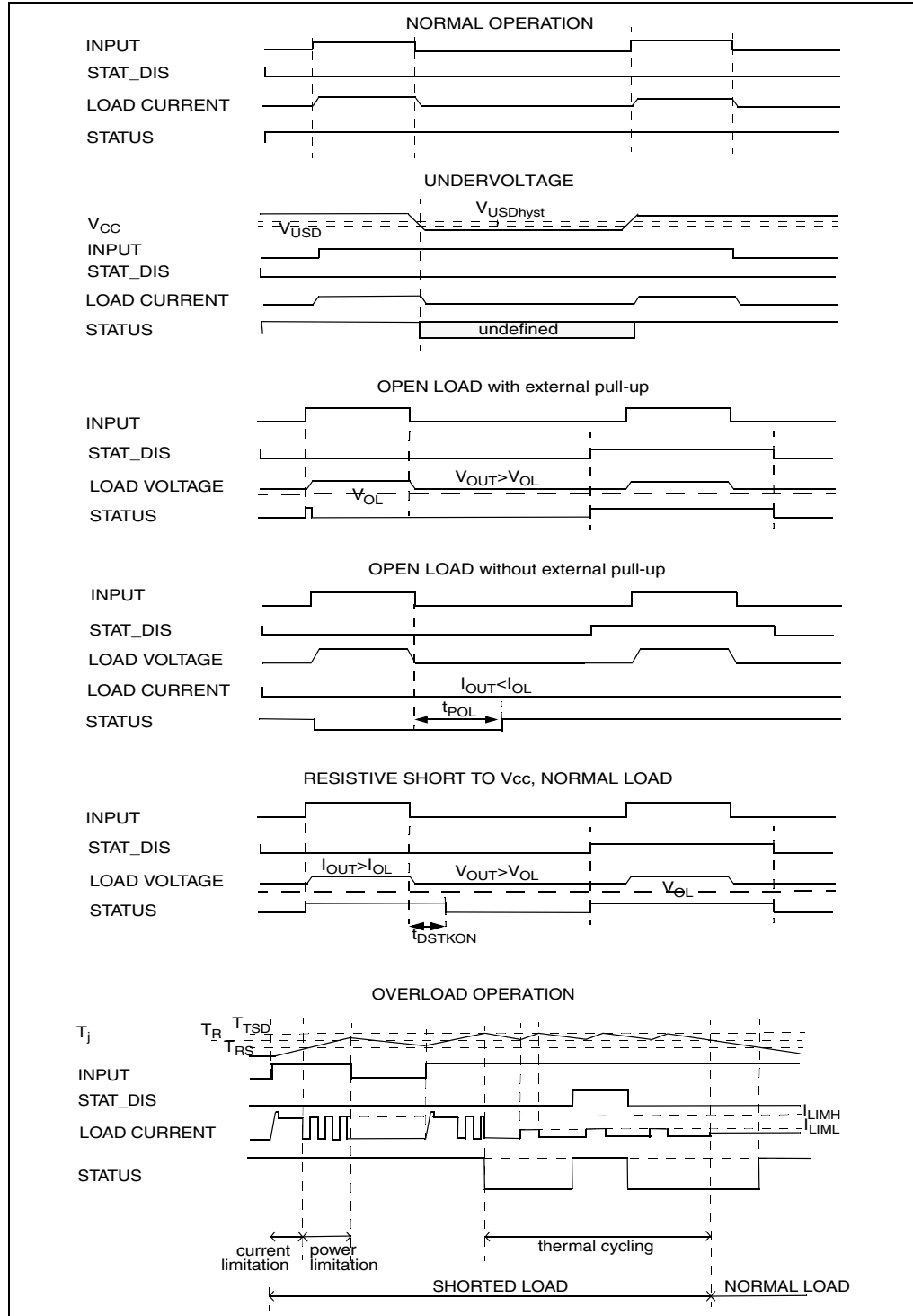
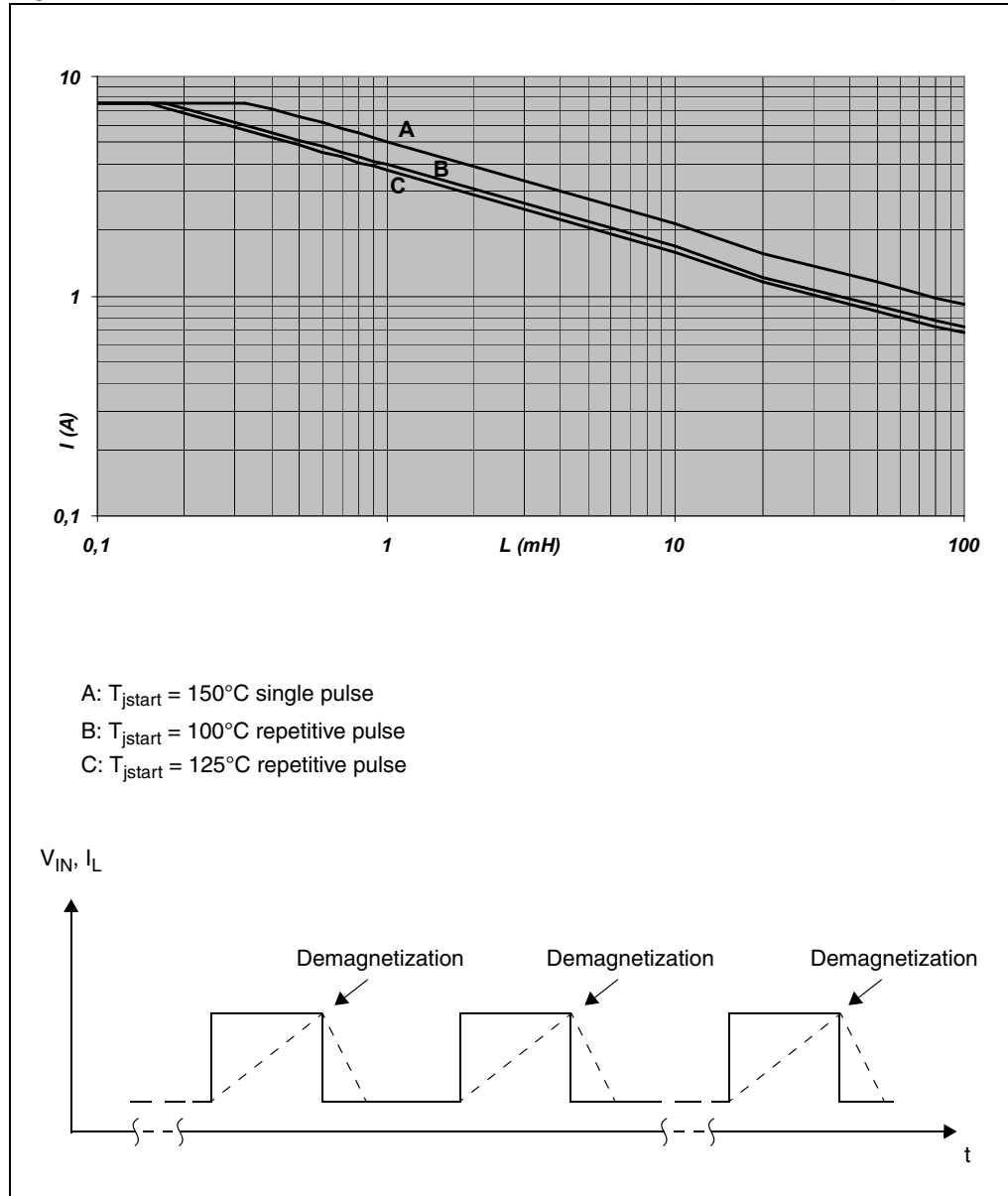

Figure 29. Waveforms



3.5 Maximum demagnetization energy ($V_{CC} = 13.5V$)

Figure 30. Maximum turn-off current versus inductance (for each channel)



Note: Values are generated with $R_L = 0\Omega$
 In case of repetitive pulses, T_{jstart} (at beginning of each demagnetization) of every pulse must not exceed the temperature specified above for curves A and B.

4 Package and PC board thermal data

4.1 PowerSSO-24 thermal data

Figure 31. PowerSSO-24 PC board

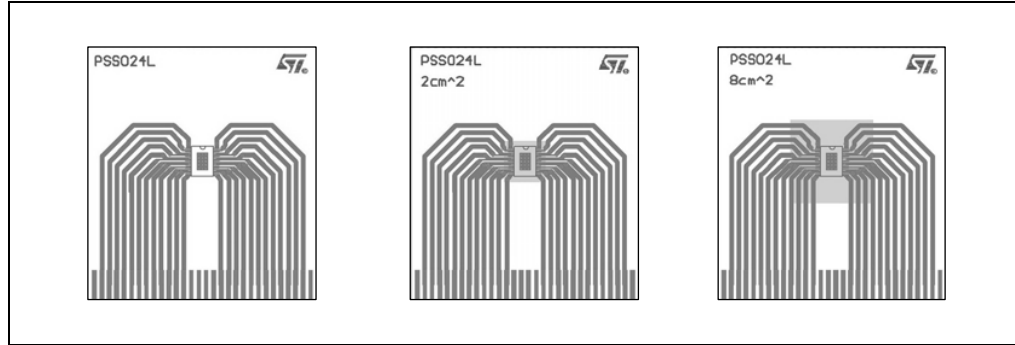

Note: Layout condition of R_{th} and Z_{th} measurements (PCB: double layer, thermal vias, FR4 area= 77mm x 86mm, PCB thickness=1.6mm, Cu thickness=70mm (front and back side), copper areas: from minimum pad lay-out to 8cm²).

Figure 32. $R_{thj-amb}$ vs PCB copper area in open box free air condition (one channel ON)

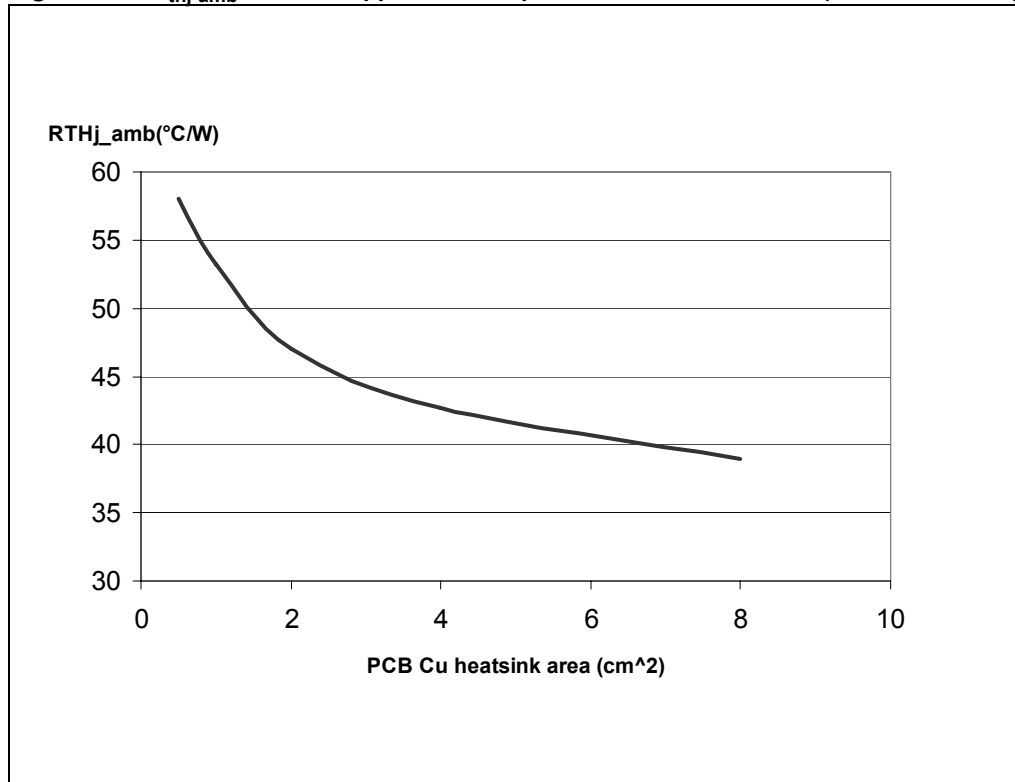

Figure 33. PowerSSO-24 thermal impedance junction ambient single pulse (one channel on)

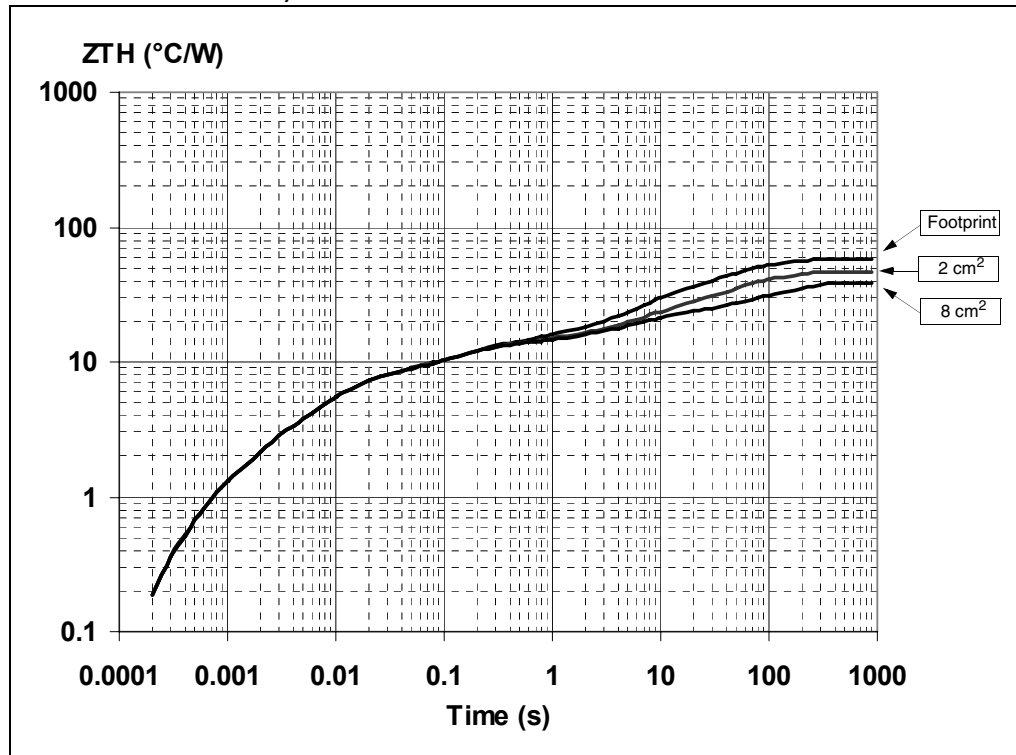
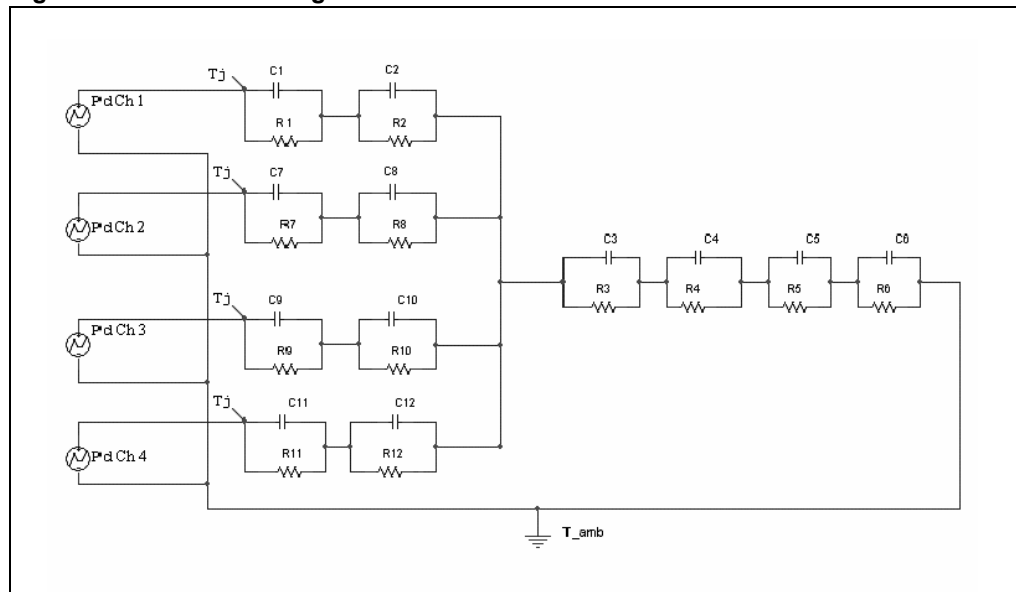

Figure 34. Thermal fitting model of a double channel HSD in PowerSSO-24⁽¹⁾



1. The fitting model is a simplified thermal tool and is valid for transient evolutions where the embedded protections (power limitation or thermal cycling during thermal shutdown) are not triggered

Equation 1: pulse calculation formula:

$$Z_{TH\delta} = R_{TH} \cdot \delta + Z_{THtp}(1 - \delta)$$

where $\delta = t_p/T$

Table 16. Thermal parameters

Area/island (cm ²)	Footprint	2	8
R1 = R7 = R9 = R11 (°C/W)	1.2		
R2 = R8 = R10 = R12 (°C/W)	6		
R3 (°C/W)	6		
R4 (°C/W)	7.7		
R5 (°C/W)	9	9	8
R6 (°C/W)	28	17	10
C1 = C7 = C9 = C11 (W.s/°C)	0.0008		
C2 = C8 = C10 = C12 (W.s/°C)	0.0016		
C3 (W.s/°C)	0.025		
C4 (W.s/°C)	0.75		
C5 (W.s/°C)	1	4	9
C6 (W.s/°C)	2.2	5	17

5 Package and packing information

5.1 ECOPACK® packages

In order to meet environmental requirements, ST offers these devices in different grades of ECOPACK® packages, depending on their level of environmental compliance. ECOPACK® specifications, grade definitions and product status are available at: www.st.com.

ECOPACK® is an ST trademark.

5.2 PowerSSO-24™ mechanical data

Figure 35. PowerSSO-24™ package dimensions

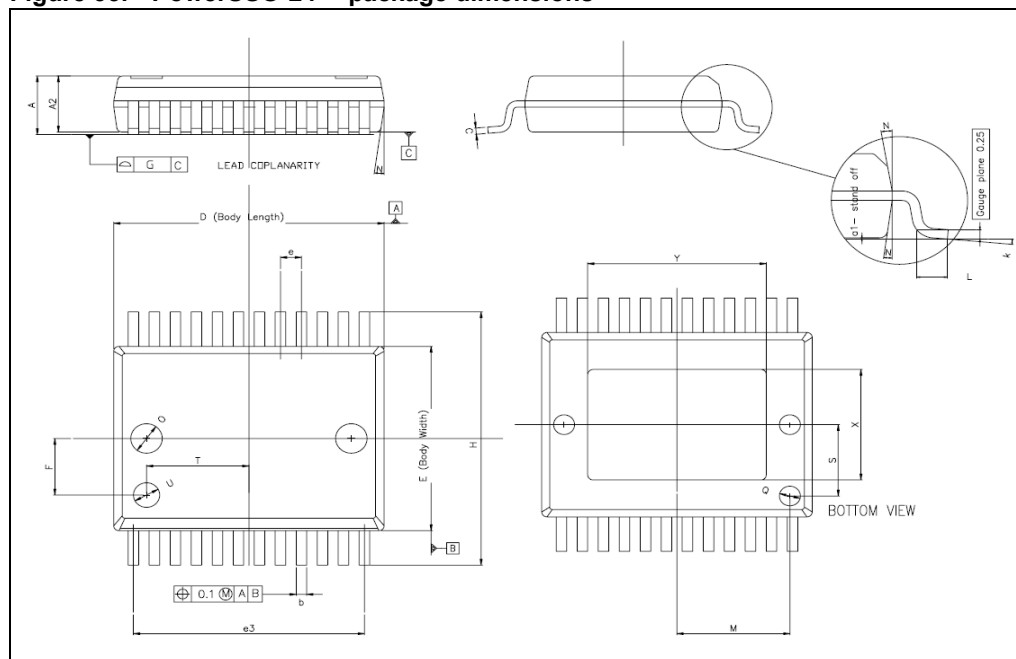

Table 17. PowerSSO-24™ mechanical data

Symbol	Millimeters		
	Min	Typ	Max
A			2.45
A2	2.15		2.35
a1	0		0.1
b	0.33		0.51
c	0.23		0.32
D	10.10		10.50
E	7.4		7.6
e		0.8	
e3		8.8	
F		2.3	
G			0.1
H	10.1		10.5
h			0.4
k	0°		8°
L	0.55		0.85
O		1.2	
Q		0.8	
S		2.9	
T		3.65	
U		1.0	
N			10°
X	4.1		4.7
Y	6.5		7.1

5.3 Packing information

Figure 36. PowerSSO-24 tube shipment (no suffix)

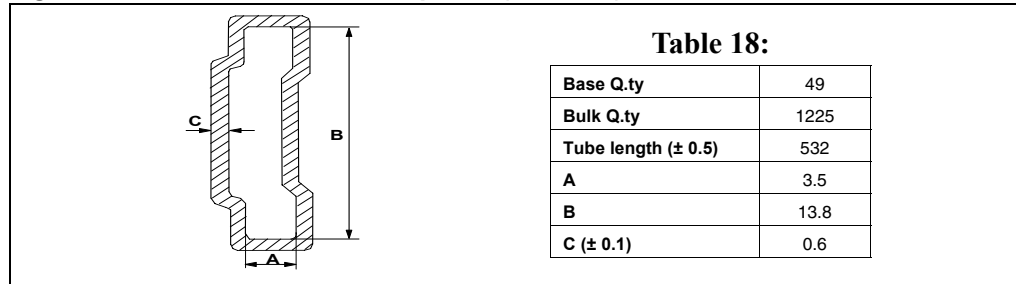
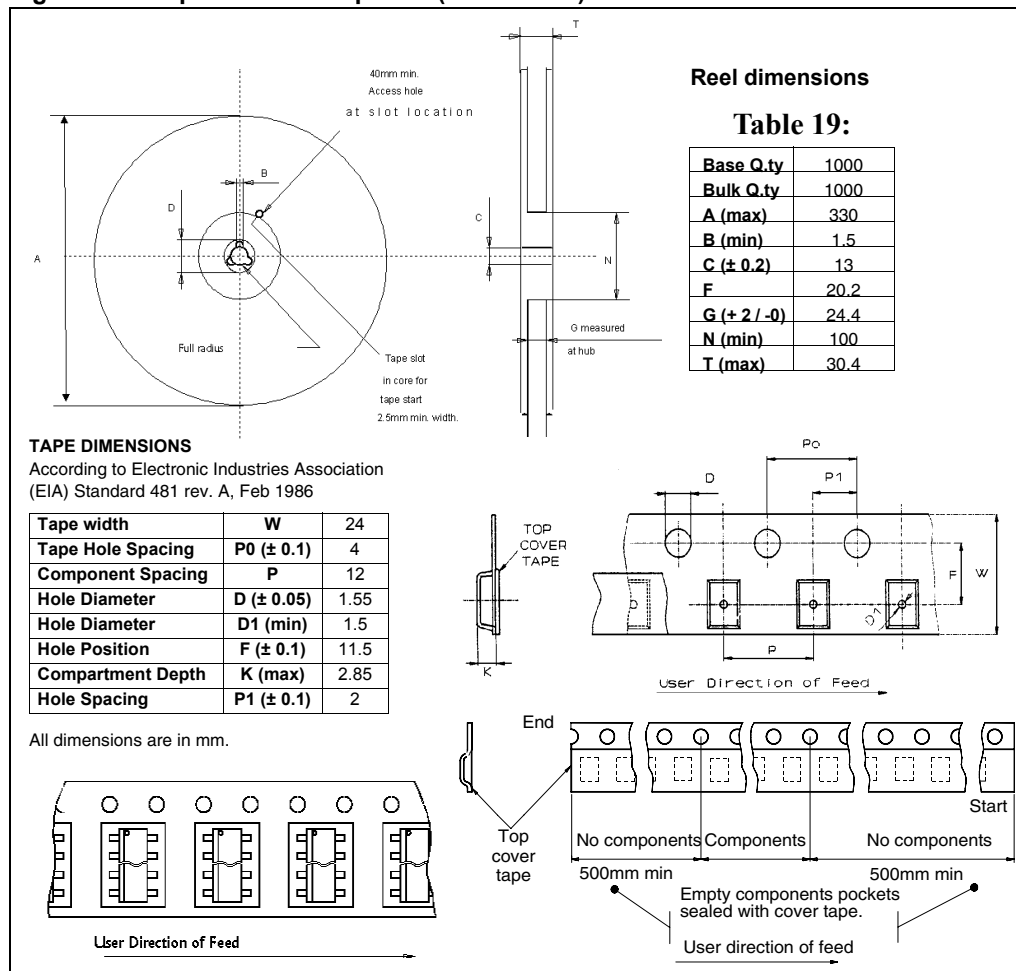

Figure 37. Tape and reel shipment (suffix “TR”)



6 Revision history

Table 20. Document revision history

Date	Revision	Changes
8-Jan-2004	1	Initial release.
20-Jan-2006	2	Major general update
15-Mar-2007	3	Reformatted and restructured. Contents, List of tables and List of figures added. <i>Section 3.5: Maximum demagnetization energy (VCC = 13.5V)</i> added. <i>Section 5.1: ECOPACK® packages</i> information added. New disclaimer added.
01-Jun-2007	4	<i>Table 4: Absolute maximum ratings</i> : EMAX entries updated. <i>Table 13: Electrical transient requirements (part 1/3)</i> : Test level values III and IV for test pulse 5b and notes updated <i>Figure 34: Thermal fitting model of a double channel HSD in PowerSSO-24⁽¹⁾</i> note added
22-Jun-2009	5	<i>Table 17: PowerSSO-24™ mechanical data</i> : – Deleted A (min) value – Changed A (max) value from 2.47 to 2.45 – Changed A2 (max) value from 2.40 to 2.35 – Changed a1 (max) value from 0.075 to 0.1 Added F and k rows
23-Jul-2009	6	Updated <i>Figure 35: PowerSSO-24™ package dimensions</i> . Updated <i>Table 17: PowerSSO-24™ mechanical data</i> : – Deleted G1 row – Added O, Q, S, T and U rows

Please Read Carefully:

Information in this document is provided solely in connection with ST products. STMicroelectronics NV and its subsidiaries ("ST") reserve the right to make changes, corrections, modifications or improvements, to this document, and the products and services described herein at any time, without notice.

All ST products are sold pursuant to ST's terms and conditions of sale.

Purchasers are solely responsible for the choice, selection and use of the ST products and services described herein, and ST assumes no liability whatsoever relating to the choice, selection or use of the ST products and services described herein.

No license, express or implied, by estoppel or otherwise, to any intellectual property rights is granted under this document. If any part of this document refers to any third party products or services it shall not be deemed a license grant by ST for the use of such third party products or services, or any intellectual property contained therein or considered as a warranty covering the use in any manner whatsoever of such third party products or services or any intellectual property contained therein.

UNLESS OTHERWISE SET FORTH IN ST'S TERMS AND CONDITIONS OF SALE ST DISCLAIMS ANY EXPRESS OR IMPLIED WARRANTY WITH RESPECT TO THE USE AND/OR SALE OF ST PRODUCTS INCLUDING WITHOUT LIMITATION IMPLIED WARRANTIES OF MERCHANTABILITY, FITNESS FOR A PARTICULAR PURPOSE (AND THEIR EQUIVALENTS UNDER THE LAWS OF ANY JURISDICTION), OR INFRINGEMENT OF ANY PATENT, COPYRIGHT OR OTHER INTELLECTUAL PROPERTY RIGHT.

UNLESS EXPRESSLY APPROVED IN WRITING BY AN AUTHORIZED ST REPRESENTATIVE, ST PRODUCTS ARE NOT RECOMMENDED, AUTHORIZED OR WARRANTED FOR USE IN MILITARY, AIR CRAFT, SPACE, LIFE SAVING, OR LIFE SUSTAINING APPLICATIONS, NOR IN PRODUCTS OR SYSTEMS WHERE FAILURE OR MALFUNCTION MAY RESULT IN PERSONAL INJURY, DEATH, OR SEVERE PROPERTY OR ENVIRONMENTAL DAMAGE. ST PRODUCTS WHICH ARE NOT SPECIFIED AS "AUTOMOTIVE GRADE" MAY ONLY BE USED IN AUTOMOTIVE APPLICATIONS AT USER'S OWN RISK.

Resale of ST products with provisions different from the statements and/or technical features set forth in this document shall immediately void any warranty granted by ST for the ST product or service described herein and shall not create or extend in any manner whatsoever, any liability of ST.

ST and the ST logo are trademarks or registered trademarks of ST in various countries.

Information in this document supersedes and replaces all information previously supplied.

The ST logo is a registered trademark of STMicroelectronics. All other names are the property of their respective owners.

© 2009 STMicroelectronics - All rights reserved

STMicroelectronics group of companies

Australia - Belgium - Brazil - Canada - China - Czech Republic - Finland - France - Germany - Hong Kong - India - Israel - Italy - Japan - Malaysia - Malta - Morocco - Philippines - Singapore - Spain - Sweden - Switzerland - United Kingdom - United States of America

www.st.com