

ISO high side smart power solid state relay

Features

Type	V _{DSS}	R _{DS(on)}	I _n ⁽¹⁾	V _{CC}
VN06	60 V	0.18 Ω	1.9 A	26 V

1. I_n= nominal current according to ISO definition for high side automotive switch.

- Maximum continuous output current^(a) : 9A @ T_c= 85°C
- 5V logic level compatible input
- Thermal shutdown
- Under voltage protection
- Open drain diagnostic output
- Inductive load fast demagnetization
- Very low standby power dissipation

a. The maximum continuous output current is the current at T_c = 85 °C for a battery voltage of 13V which does not activate self protection.

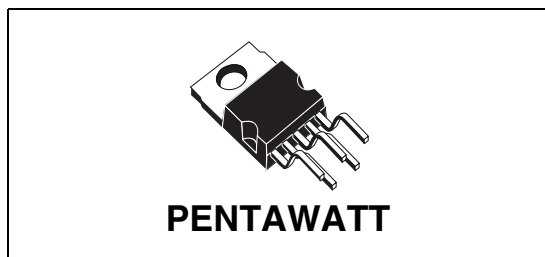

Description

The VN06 is a monolithic device made using STMicroelectronics Vertical Intelligent Power technology, intended for driving resistive or inductive loads with one side grounded. Built-in thermal shutdown protects the chip from over temperature and short circuit. The open Drain diagnostic output indicates: open load in off state and in on state, output shorted to V_{CC} and overtemperature. Fast demagnetization of inductive loads is achieved by negative (-18V) load voltage at turn-off.

Table 1. Device summary

Package	Order codes
PENTAWATT	VN06

Contents

1	Block diagram and pin description	5
2	Electrical specifications	6
2.1	Absolute maximum ratings	6
2.2	Thermal data	7
2.3	Electrical characteristics	7
3	Application information	12
3.1	Functional description	13
3.2	Protecting the device against load dump - test pulse 5	13
3.3	Protecting the device against reverse battery	13
4	Package and packing information	14
4.1	ECOPACK® packages	14
4.2	PENTAWATT mechanical data	14
5	Revision history	16

List of tables

Table 1.	Device summary	1
Table 2.	Absolute maximum ratings	6
Table 3.	Thermal data.	7
Table 4.	Power	7
Table 5.	Switching ($V_{CC}=13V$)	7
Table 6.	Logic inputs.	8
Table 7.	Protections and diagnostics	8
Table 8.	Truth table.	10
Table 9.	PENTAWATT mechanical data	15
Table 10.	Document revision history	16

List of figures

Figure 1.	Block diagram	5
Figure 2.	Configuration diagram (top view)	5
Figure 3.	Current and voltage conventions	6
Figure 4.	$I_{OL(off)}$ test circuit.	9
Figure 5.	t_{povl} , t_{pol} ISO definition	9
Figure 6.	Switching time waveforms	10
Figure 7.	Waveforms	11
Figure 8.	Over current test circuit.	11
Figure 9.	Typical application circuit with a schottky diode for reverse supply protection	12
Figure 10.	Typical application circuit with separate signal ground.	12
Figure 11.	PENTAWATT package dimensions	14

1 Block diagram and pin description

Figure 1. Block diagram

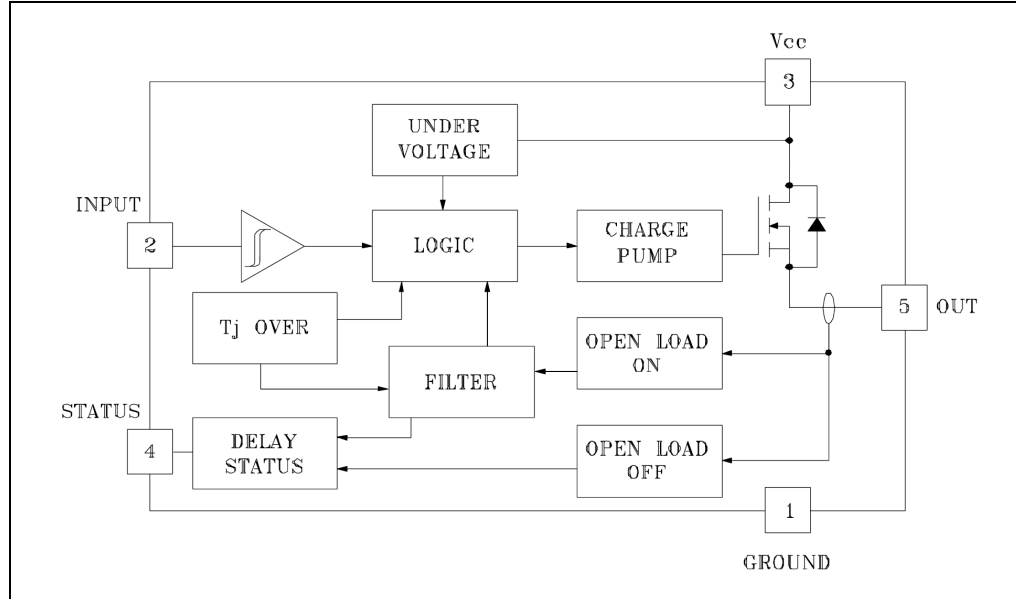
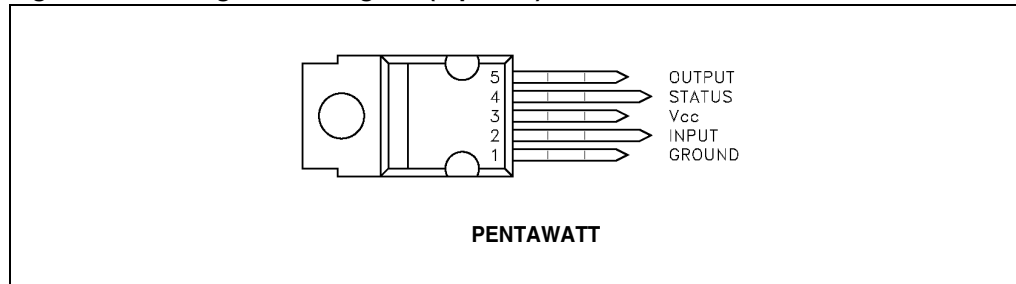
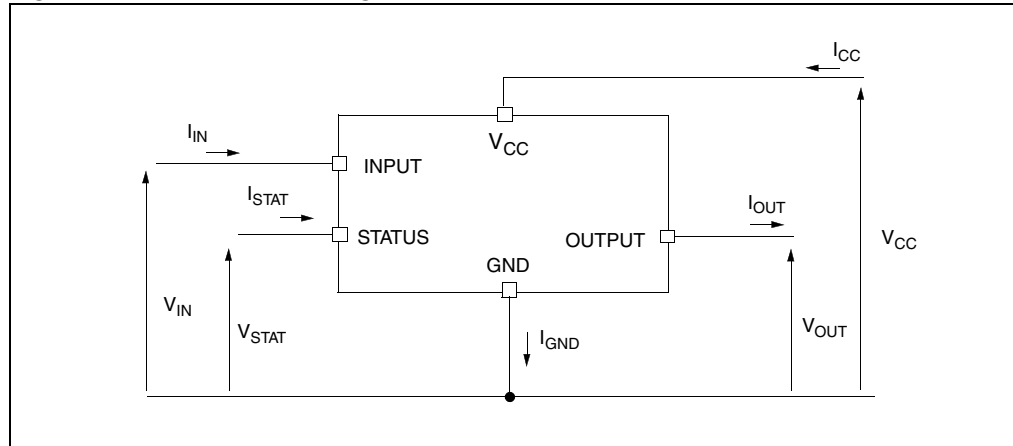

Figure 2. Configuration diagram (top view)



2 Electrical specifications

Figure 3. Current and voltage conventions



2.1 Absolute maximum ratings

Stressing the device above the rating listed in the “Absolute maximum ratings” table may cause permanent damage to the device. These are stress ratings only and operation of the device at these or any other conditions above those indicated in the operating sections of this specification is not implied. Exposure to Absolute maximum rating conditions for extended periods may affect device reliability. Refer also to the STMicroelectronics sure program and other relevant quality document.

Table 2. Absolute maximum ratings

Symbol	Parameter	Value	Unit
$V_{(BR)DSS}$	Drain-Source breakdown voltage	60	V
I_{OUT}	Output current (cont.) at $T_c = 85^\circ\text{C}$	9	A
I_R	Reverse output current at $T_c = 85^\circ\text{C}$	-9	A
I_{IN}	Input current	± 10	mA
$-V_{CC}$	Reverse supply voltage	-4	V
I_{STAT}	Status current	± 10	mA
V_{ESD}	Electrostatic discharge (1.5 k Ω , 100 pF)	2000	V
P_{tot}	Power dissipation at $T_c = 85^\circ\text{C}$	27	W
T_j	Junction operating temperature	-40 to 150	$^\circ\text{C}$
T_{stg}	Storage temperature	-55 to 150	$^\circ\text{C}$

2.2 Thermal data

Table 3. Thermal data

Symbol	Parameter	Max. value	Unit
$R_{thj-case}$	Thermal resistance junction-case	2.4	°C/W
$R_{thj-amb}$	Thermal resistance junction-ambient	60	°C/W

2.3 Electrical characteristics

Values specified in this section are for $V_{CC} = 13V$; $-40^{\circ}C < T_j < 125^{\circ}C$, unless otherwise stated.

Table 4. Power

Symbol	Parameter	Test conditions	Min.	Typ.	Max.	Unit
V_{CC}	Supply voltage		5.5	13	26	V
$I_n^{(1)}$	Nominal current	$T_c = 85^{\circ}C$; $V_{DS(on)} < 0.5$	1.9			A
R_{on}	On state resistance	$I_{OUT} = 1.9 A$ $I_{OUT} = 1.9 A T_j = 25^{\circ}C$		0.18	0.36	Ω Ω
I_S	Supply current	Off state $T_j \geq 25^{\circ}C$ On state			50 15	μA mA
$V_{DS(max)}$	Maximum voltage drop	$I_{OUT} = 8.5A$; $T_c = 85^{\circ}C$			2.75	V

1. The nominal current is the current at $T_c = 85^{\circ}C$ for battery voltage of 13V which produces a voltage drop of 0.5V.

Table 5. Switching ($V_{CC}=13V$)

Symbol	Parameter	Test conditions	Min.	Typ.	Max.	Unit
$t_{d(on)}$	Turn-on delay time of output current	$I_{OUT} = 1.9 A$ resistive load Input rise time $< 0.1 \mu s$		20		μs
t_r	Rise time of output current	$I_{OUT} = 1.9 A$ resistive load Input rise time $< 0.1 \mu s$		20		μs
$t_{d(off)}$	Turn-off delay time of output current	$I_{OUT} = 1.9 A$ resistive load Input rise time $< 0.1 \mu s$		25		μs
t_f	Fall time of output current	$I_{OUT} = 1.9 A$ resistive load Input rise time $< 0.1 \mu s$		6		μs
$dV_{OUT}/dt_{(on)}$	Turn-on current slope	$I_{OUT} = 1.9 A$ $I_{OUT} = I_{OV}$		0.08	0.5 1	$A/\mu s$ $A/\mu s$
$dV_{OUT}/dt_{(off)}$	Turn-off current slope	$I_{OUT} = 1.9 A$ $I_{OUT} = I_{OV}$		0.2	3 3	$A/\mu s$ $A/\mu s$
V_{demag}	Inductive load clamp voltage	$I_{OUT} = 1.9 A$; $L = 1mH$	-24	-18	-14	V

Table 6. Logic inputs

Symbol	Parameter	Test conditions	Min.	Typ.	Max.	Unit
V_{IL}	Input low level voltage				0.8	V
$V_{IH}^{(1)}$	Input high level voltage		2			V
$V_{I(hyst.)}$	Input hysteresis voltage			0.5		V
I_{IN}	Input current	$V_{IN} = 5\text{ V}$		250	500	μA
		$V_{IN} = 2\text{ V}$			250	μA
		$V_{IN} = 0.8\text{ V}$	25			μA
V_{ICL}	Input clamp voltage	$I_{IN} = 10\text{ mA}$	5.5	6		V
		$I_{IN} = -10\text{ mA}$		-0.7	-0.3	V

1. The V_{IH} is internally clamped at 6V about. It is possible to connect this pin to an higher voltage via an external resistor calculated to not exceed 10 mA at the input pin.

Table 7. Protections and diagnostics

Symbol	Parameter	Test conditions	Min.	Typ.	Max.	Unit
V_{STAT}	Status voltage output low	$I_{STAT} = 1.6\text{ mA}$			0.4	V
V_{USD}	Under voltage shutdown			5		V
V_{SCL}	Status clamp voltage	$I_{STAT} = 10\text{ mA}$		6		V
		$I_{STAT} = -10\text{ mA}$		-0.7		V
I_{OV}	Over current	$R_{LOAD} < 10\text{ m}\Omega$ $-40 \leq T_c \leq 125\text{ }^\circ\text{C}$			60	A
I_{AV}	Average current in short circuit	$R_{LOAD} < 10\text{ m}\Omega$ $T_c = 85\text{ }^\circ\text{C}$		1.4		A
I_{OL}	Open load current level		5	80	180	mA
T_{TSD}	Thermal shutdown temperature		140			$^\circ\text{C}$
T_R	Reset temperature		125			$^\circ\text{C}$
$V_{OL}^{(1)}$	Open load voltage level	Off state (see Figure 4.)	2.5	3.75	5	V
$t_{1(on)}^{(2)}$	Open load filtering time		1	5	10	ms
$t_{1(off)}^{(3)}$	Open load filtering time		1	5	10	ms
$t_{2(off)}^{(4)}$	Open load filtering time		1	5	10	ms
$t_{povl}^{(5)}$	Status delay	(see Figure 5.)		5	10	μs
$t_{pol}^{(5)}$	Status delay	(see Figure 5.)	50	700		μs

- $I_{OL(off)} = (V_{CC} - V_{OL})/R_{OL}$.
- $t_{1(on)}$: minimum open load duration which activates the status output
- $t_{1(off)}$: minimum load recovery time which deactivates the status output
- $t_{2(off)}$: minimum on time after thermal shut down which deactivates status output
- t_{povl} t_{pol} : ISO definition (see figure)

Figure 4. $I_{OL(off)}$ test circuit

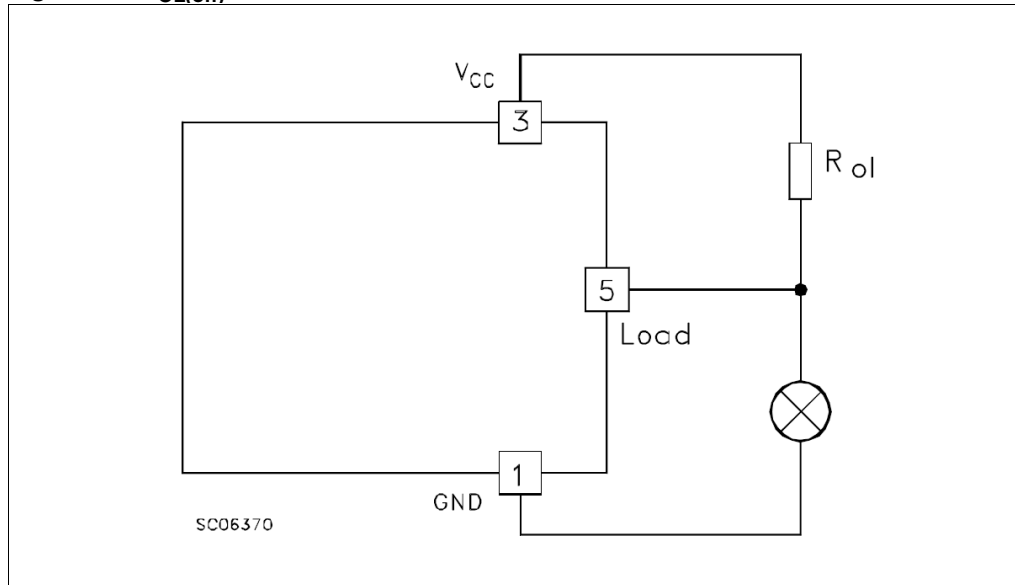

Figure 5. t_{povl} , t_{pol} ISO definition

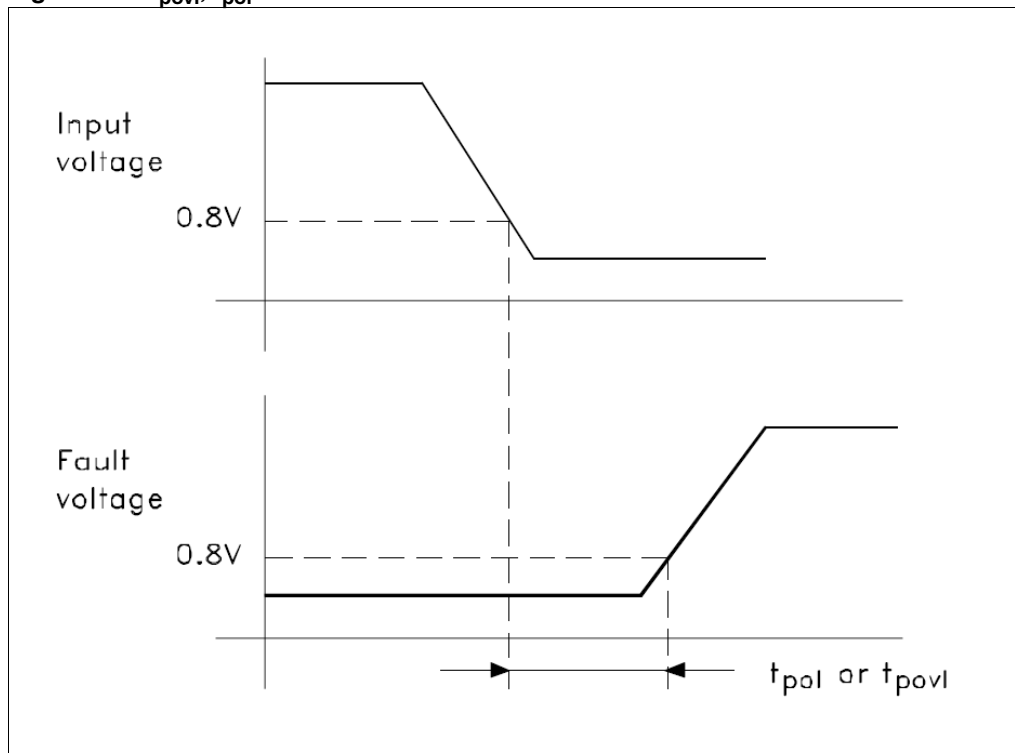

Figure 6. Switching time waveforms

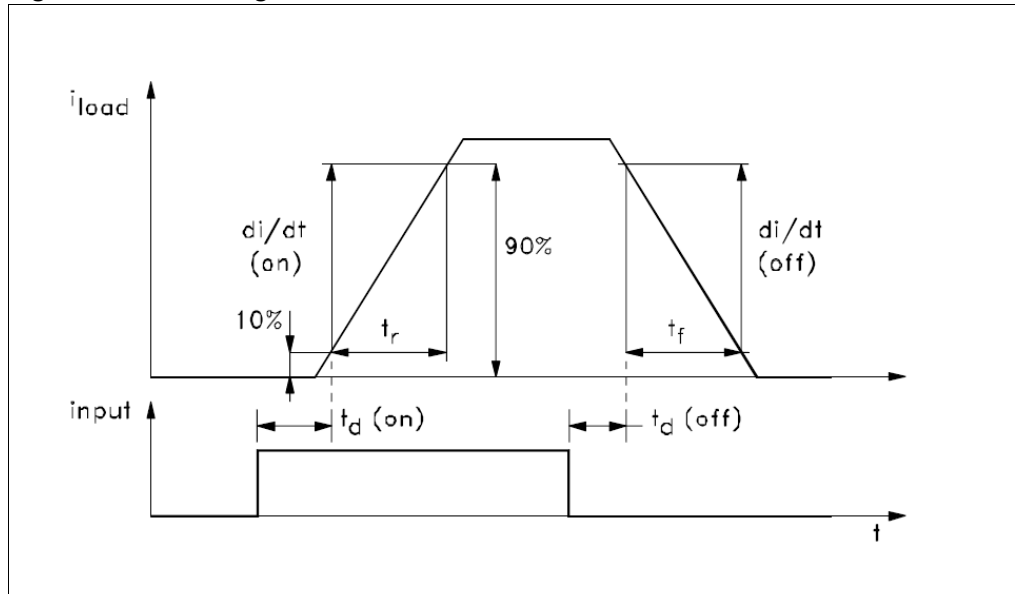

Table 8. Truth table

Conditions	Input	Output	Diagnostic
Normal operation	L	L	H
	H	H	H
Open circuit (no load)	H	H	L
Over-temperature	H	L	L
Under-voltage	X	L	H
Short load to V_{CC}	L	H	L

Figure 7. Waveforms

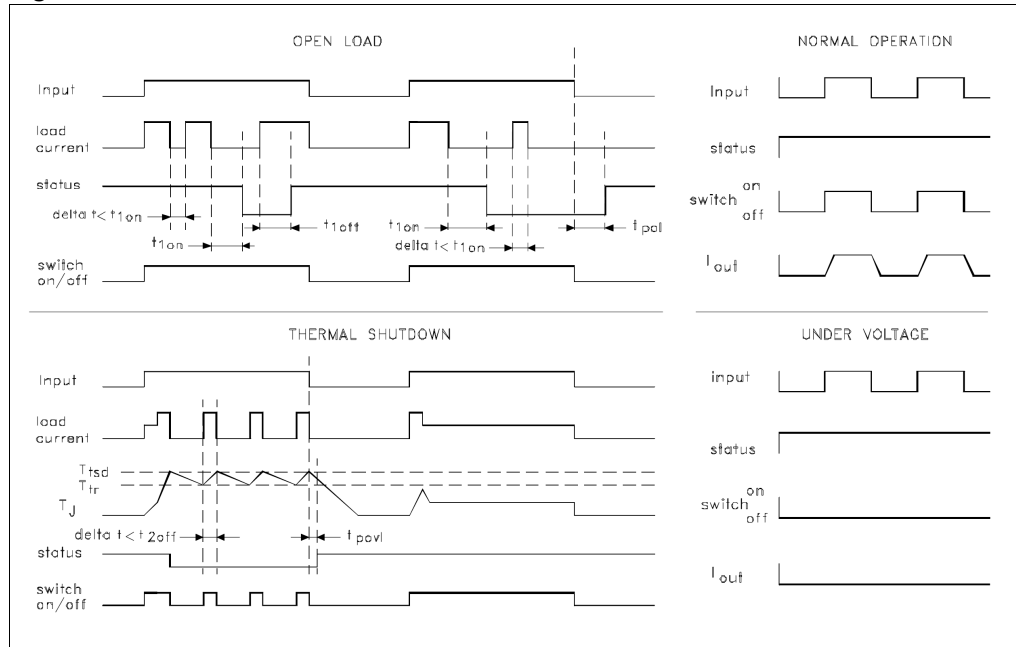
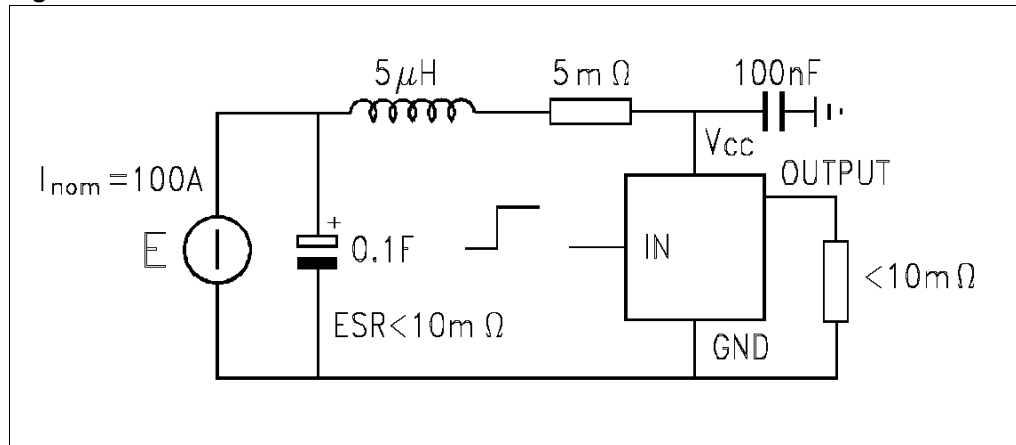

Figure 8. Over current test circuit



3 Application information

Figure 9. Typical application circuit with a schottky diode for reverse supply protection

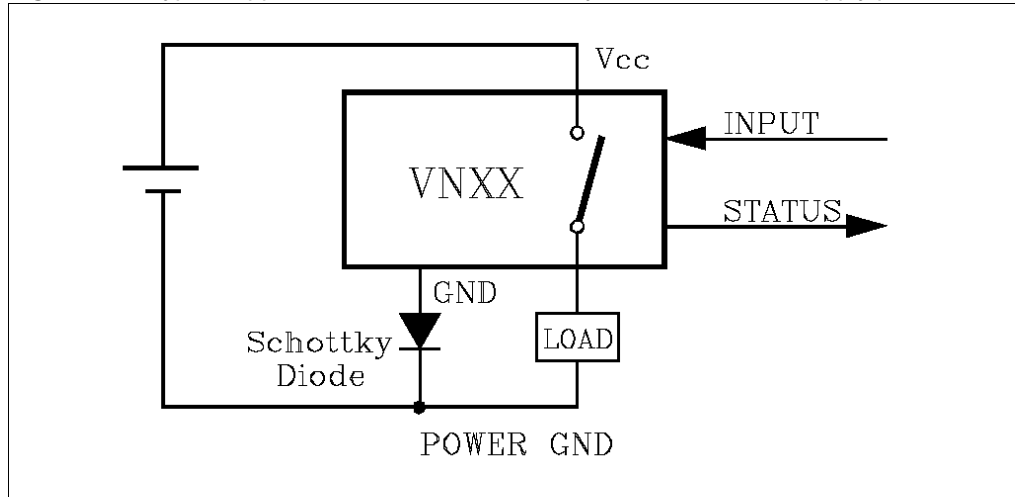
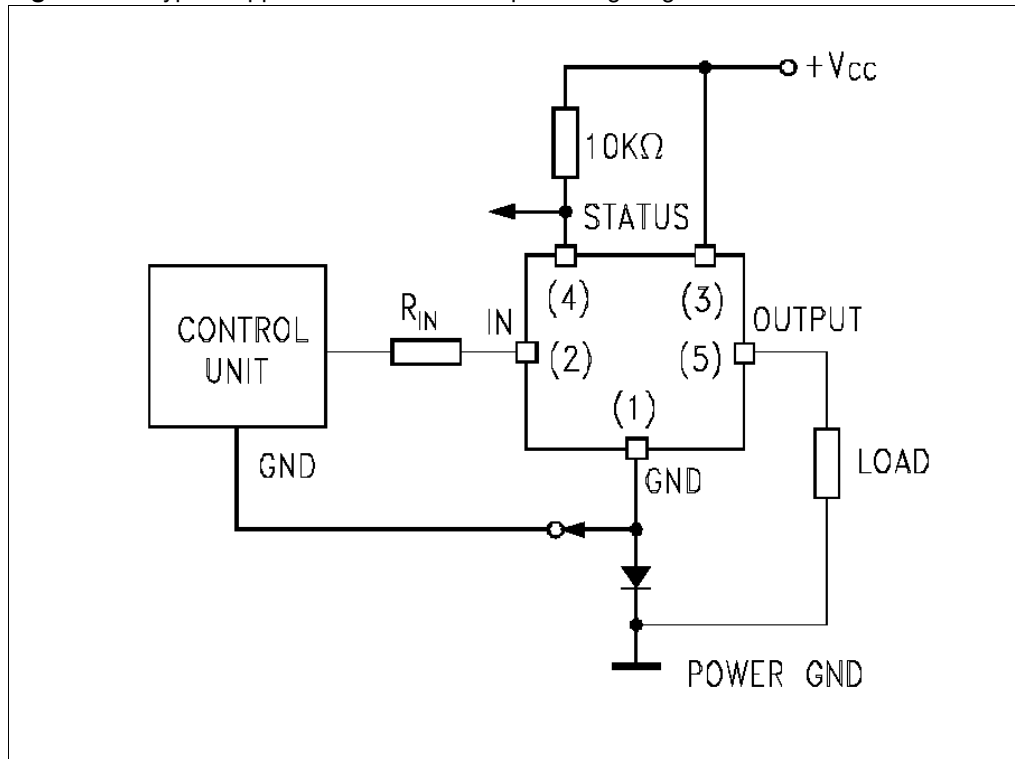

Figure 10. Typical application circuit with separate signal ground



3.1 Functional description

The device has a diagnostic output which indicates open load conditions in off state as well as in on state, output shorted to V_{CC} and overtemperature. The truth table shows input, diagnostic and output voltage level in normal operation and in fault conditions. The output signals are processed by internal logic. The open load diagnostic output has a 5 ms filtering. The filter gives a continuous signal for the fault condition after an initial delay of about 5 ms. This means that a disconnection during normal operation, with a duration of less than 5 ms does not affect the status output. Equally, any re-connection of less than 5 ms during a disconnection duration does not affect the status output. No delay occur for the status to go low in case of overtemperature conditions. From the falling edge of the input signal the status output initially low in fault condition (over temperature or open load) will go back with a delay (t_{povl}) in case of overtemperature condition and a delay (t_{pol}) in case of open load. These feature fully comply with International Standard Office (I.S.O.) requirement for automotive High Side Driver. To protect the device against short circuit and over current conditions, the thermal protection turns the integrated Power MOS off at a minimum junction temperature of 140 °C. When the temperature returns to 125 °C the switch is automatically turned on again. In short circuit the protection reacts with virtually no delay, the sensor being located in the region of the die where the heat is generated. Driving inductive loads, an internal function of the device ensures the fast demagnetization with a typical voltage (V_{demag}) of -18V. This function allows to greatly reduce the power dissipation according to the formula: $P_{dem} = 0.5^2 L_{load}^2 (I_{load})^2 [(V_{CC} + V_{demag}) / V_{demag}]^2 f$ where f = switching frequency and V_{demag} = demagnetization voltage. Based on this formula it is possible to know the value of inductance and/or current to avoid a thermal shutdown. The maximum inductance which causes the chip temperature to reach the shutdown temperature in a specific thermal environment, is in fact a function of the load current for a fixed V_{CC} , V_{demag} and f .

3.2 Protecting the device against load dump - test pulse 5

The device is able to withstand the test pulse No. 5 at level II ($V_s = 46.5V$) according to the ISO T/R 7637/1 without any external component. This means that all functions of the device are performed as designed after exposure to disturbance at level II. The VN03 is able to withstand the test pulse No.5 at level III adding an external resistor of 150 ohm between pin 1 and ground plus a filter capacitor of 1000 μF between pin 3 and ground (if $R_{LOAD} \leq 20 \Omega$).

3.3 Protecting the device against reverse battery

The simplest way to protect the device against a continuous reverse battery voltage (-26V) is to insert a schottky diode between pin 1 (GND) and ground, as shown in the typical application circuit ([Figure 9](#)). The consequences of the voltage drop across this diode are as follows:

- If the input is pulled to power GND, a negative voltage of $-V_F$ is seen by the device. (V_{IL} , V_{IH} thresholds and V_{STAT} are increased by V_F with respect to power GND).
- The undervoltage shutdown level is increased by V_F .

If there is no need for the control unit to handle external analog signals referred to the power GND, the best approach is to connect the reference potential of the control unit to node [1] (see [Figure 10](#)), which becomes the common signal GND for the whole control board avoiding shift of V_{ih} , V_{il} and V_{stat} . This solution allows the use of a standard diode.

4 Package and packing information

4.1 ECOPACK[®] packages

In order to meet environmental requirements, ST offers these devices in ECOPACK[®] packages. ECOPACK[®] packages are lead-free. The category of Second Level Interconnect is marked on the package and on the inner box label, in compliance with JEDEC Standard JESD97. The maximum ratings related to soldering conditions are also marked on the inner box label.

ECOPACK is an ST trademark. ECOPACK specifications are available at www.st.com.

4.2 PENTAWATT mechanical data

Figure 11. PENTAWATT package dimensions

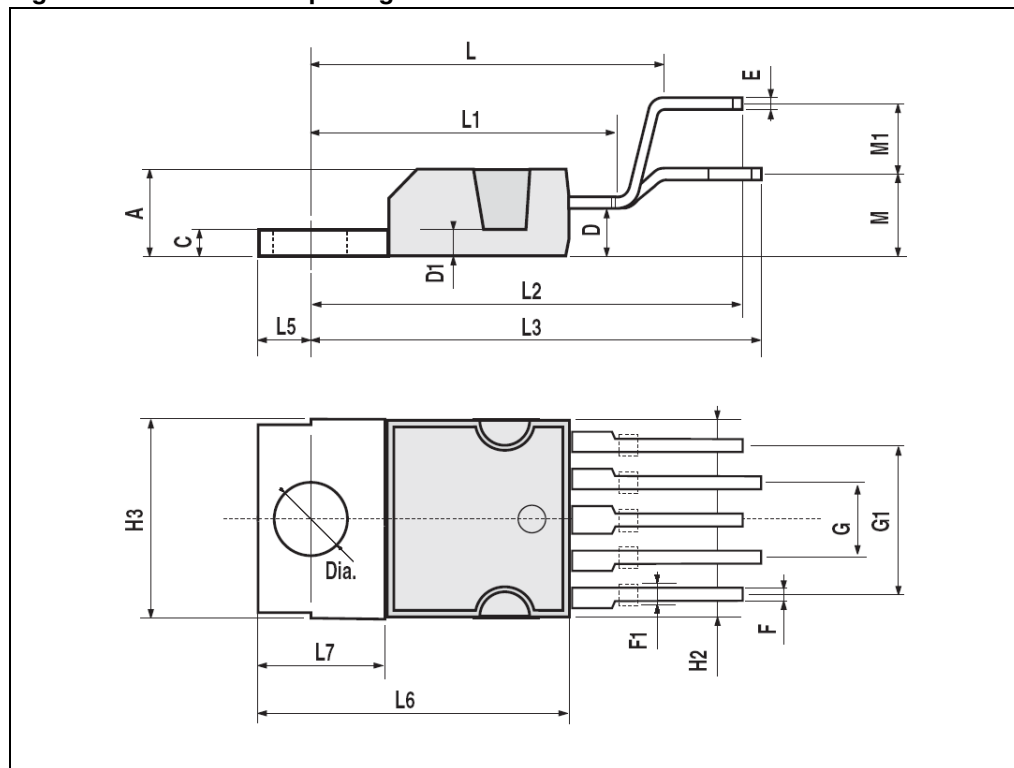

Table 9. PENTAWATT mechanical data

Dim.	mm		
	Min.	Typ.	Max.
A			4.8
C			1.37
D	2.4		2.8
D1	1.2		1.35
E	0.35		0.55
F	0.8		1.05
F1	1		1.4
G	3.2	3.4	3.6
G1	6.6	6.8	7
H2			10.4
H3	10.05		10.4
L		17.85	
L1		15.75	
L2		21.4	
L3		22.5	
L5	2.6		3
L6	15.1		15.8
L7	6		6.6
M		4.5	
M1		4	
Diam.	3.65		3.85

5 Revision history

Table 10. Document revision history

Date	Revision	Changes
Sep-1994	1	Initial release.
06-Nov-2008	2	Document converted in corporate template. Added Section 4.1: ECOPACK® packages .

Please Read Carefully:

Information in this document is provided solely in connection with ST products. STMicroelectronics NV and its subsidiaries ("ST") reserve the right to make changes, corrections, modifications or improvements, to this document, and the products and services described herein at any time, without notice.

All ST products are sold pursuant to ST's terms and conditions of sale.

Purchasers are solely responsible for the choice, selection and use of the ST products and services described herein, and ST assumes no liability whatsoever relating to the choice, selection or use of the ST products and services described herein.

No license, express or implied, by estoppel or otherwise, to any intellectual property rights is granted under this document. If any part of this document refers to any third party products or services it shall not be deemed a license grant by ST for the use of such third party products or services, or any intellectual property contained therein or considered as a warranty covering the use in any manner whatsoever of such third party products or services or any intellectual property contained therein.

UNLESS OTHERWISE SET FORTH IN ST'S TERMS AND CONDITIONS OF SALE ST DISCLAIMS ANY EXPRESS OR IMPLIED WARRANTY WITH RESPECT TO THE USE AND/OR SALE OF ST PRODUCTS INCLUDING WITHOUT LIMITATION IMPLIED WARRANTIES OF MERCHANTABILITY, FITNESS FOR A PARTICULAR PURPOSE (AND THEIR EQUIVALENTS UNDER THE LAWS OF ANY JURISDICTION), OR INFRINGEMENT OF ANY PATENT, COPYRIGHT OR OTHER INTELLECTUAL PROPERTY RIGHT.

UNLESS EXPRESSLY APPROVED IN WRITING BY AN AUTHORIZED ST REPRESENTATIVE, ST PRODUCTS ARE NOT RECOMMENDED, AUTHORIZED OR WARRANTED FOR USE IN MILITARY, AIR CRAFT, SPACE, LIFE SAVING, OR LIFE SUSTAINING APPLICATIONS, NOR IN PRODUCTS OR SYSTEMS WHERE FAILURE OR MALFUNCTION MAY RESULT IN PERSONAL INJURY, DEATH, OR SEVERE PROPERTY OR ENVIRONMENTAL DAMAGE. ST PRODUCTS WHICH ARE NOT SPECIFIED AS "AUTOMOTIVE GRADE" MAY ONLY BE USED IN AUTOMOTIVE APPLICATIONS AT USER'S OWN RISK.

Resale of ST products with provisions different from the statements and/or technical features set forth in this document shall immediately void any warranty granted by ST for the ST product or service described herein and shall not create or extend in any manner whatsoever, any liability of ST.

ST and the ST logo are trademarks or registered trademarks of ST in various countries.

Information in this document supersedes and replaces all information previously supplied.

The ST logo is a registered trademark of STMicroelectronics. All other names are the property of their respective owners.

© 2008 STMicroelectronics - All rights reserved

STMicroelectronics group of companies

Australia - Belgium - Brazil - Canada - China - Czech Republic - Finland - France - Germany - Hong Kong - India - Israel - Italy - Japan - Malaysia - Malta - Morocco - Singapore - Spain - Sweden - Switzerland - United Kingdom - United States of America

www.st.com

