

High Speed, Monolithic Pin Driver

The EL7154 three-state pin driver is particularly well suited for ATE and level shifting applications. The 4A peak drive capability, makes the EL7154 an excellent choice when driving high speed capacitive lines.

The P-Channel MOSFET is completely isolated from the power supply, providing a high degree of flexibility. Pin (7) can be grounded, and the output can be taken from pin (8) when a “source follower” output is desired. The N-Channel MOSFET has an isolated drain, but shares a common bus with pre-drivers and level shifter circuits. This is necessary to ensure that the N-Channel device can turn off effectively when V_L goes below GND. In some power-FET and IGBT applications, negative drive is desirable to insure effective turn-off. The EL7154 can be used in these applications by returning V_L to a moderate negative potential.

Pinout

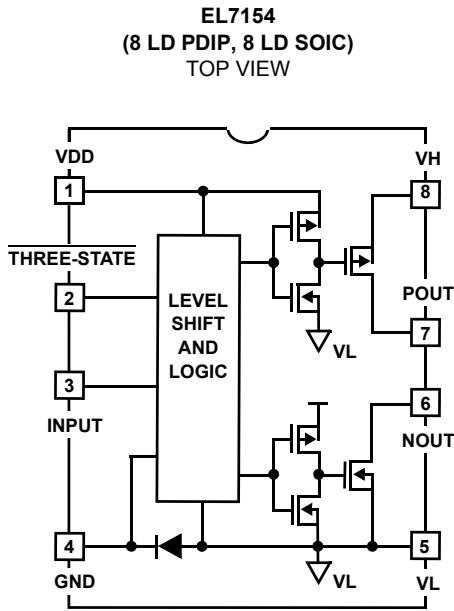

Features

- Comparatively low cost
- Three-State output
- 3V and 5V Input compatible
- Clocking speeds up to 10MHz
- 20ns Switching/delay time
- 4A Peak drive
- Isolated drains
- Low output impedance: 2.5Ω
- Low quiescent current: 5mA
- Wide operating voltage: 4.5V to 16V
- Isolated P-Channel device
- Separate ground and V_L pins
- Pb-free available (RoHS compliant)

Applications

- Loaded circuit board testers
- Digital testers
- Level shifting below GND
- IGBT drivers
- CCD drivers

Truth Table

THREE-STATE	INPUT	P _{OUT}	N _{OUT}
0	0	Open	Open
0	1	Open	Open
1	0	HIGH	Open
1	1	Open	LOW

Manufactured under U.S. Patent Nos. 5,334,883, #5,341,047, #5,352,578, #5,352,389, #5,351,012, #5,374,898

Ordering Information

PART NUMBER	PART MARKING	PACKAGE	PKG. DWG. #
EL7154CN	EL7154CN	8 Ld PDIP	MDP0031
EL7154CNZ	EL7154CN Z	8 Ld PDIP* (Pb-free)	MDP0031
EL7154CS	7154CS	8 Ld SOIC	MDP0027
EL7154CS-T7**	7154CS	8 Ld SOIC	MDP0027
EL7154CS-T13**	7154CS	8 Ld SOIC	MDP0027
EL7154CSZ (See Note)	7154CSZ	8 Ld SOIC (Pb-free)	MDP0027
EL7154CSZ-T7** (See Note)	7154CSZ	8 Ld SOIC (Pb-free)	MDP0027
EL7154CSZ-T13** See Note)	7154CSZ	8 Ld SOIC (Pb-free)	MDP0027

*Pb-free PDIPs can be used for through hole wave solder processing only. They are not intended for use in Reflow solder processing applications.

**Add "-T" or "-TK" suffix for tape and reel. Please refer to TB347 for details on reel specifications.

NOTE: These Intersil Pb-free plastic packaged products employ special Pb-free material sets; molding compounds/die attach materials and 100% matte tin plate PLUS ANNEAL - e3 termination finish, which is RoHS compliant and compatible with both SnPb and Pb-free soldering operations. Intersil Pb-free products are MSL classified at Pb-free peak reflow temperatures that meet or exceed the Pb-free requirements of IPC/JEDEC J STD-020.

Nominal Operating Voltage Range

PIN	MIN	MAX
V_L	-3	0
V_{DD} to V_L	5	15
V_H to V_L	2	15
V_{DD} to V_H	-0.5	15
V_{DD}	5	15

Absolute Maximum Ratings ($T_A = +25^\circ\text{C}$)

Supply (V_{DD} to V_L ; V_H to V_L , V_H to GND), $V+$ to V_H	16.5V
V_L to GND	-5V
Input Pins	-0.3V below V_L to +0.3V above V_{DD}
Peak Output Current4A

Thermal Information

Storage Temperature Range	-65°C to +150°C
Ambient Operating Temperature	-40°C to +85°C
Operating Junction Temperature	+125°C
Power Dissipation	
SOIC570mW
PDIP*1050mW
Pb-free reflow profile	see link below
http://www.intersil.com/pbfree/Pb-FreeReflow.asp	
*Pb-free PDIPs can be used for through hole wave solder processing only. They are not intended for use in Reflow solder processing applications	

CAUTION: Do not operate at or near the maximum ratings listed for extended periods of time. Exposure to such conditions may adversely impact product reliability and result in failures not covered by warranty.

NOTE:

- Limits established by characterization and are not production tested.

IMPORTANT NOTE: All parameters having Min/Max specifications are guaranteed. Typical values are for information purposes only. Unless otherwise noted, all tests are at the specified temperature and are pulsed tests, therefore: $T_J = T_C = T_A$

DC Electrical Specifications $T_A = +25^\circ\text{C}$, $V_{DD} = +12\text{V}$, $V_H = +12\text{V}$, $V_L = -3\text{V}$, unless otherwise specified.

PARAMETER	DESCRIPTION	TEST CONDITIONS	MIN	TYP	MAX	UNITS
INPUT						
V_{IH}	Logic "1" Input Voltage		2.4			V
I_{IH}	Logic "1" Input Current	$V_{IH} = V_{DD}$		0.1	10	μA
V_{IL}	Logic "0" Input Voltage				0.6	V
I_{IL}	Logic "0" Input Current	$V_{IL} = 0\text{V}$		0.1	10	μA
V_{HVS}	Input Hysteresis			0.3		V
OUTPUT						
R_{OH}	Pull-Up Resistance	$I_{OUT} = -100\text{mA}$		1.5	4	Ω
R_{OL}	Pull-Down Resistance	$I_{OUT} = +100\text{mA}$		2	4	Ω
I_{OUT}	Output Leakage Current	V_{DD}/GND		0.2	10	μA
I_{PK}	Peak Output Current	Source/Sink		4.0		A
I_{DC} (Note 1)	Continuous Output Current	Source/Sink	200			mA
POWER SUPPLY						
I_S	Power Supply Current	Inputs = V_{DD}		1	2.5	mA
V_S	Operating Voltage		4.5		16	V
I_G	Current to GND (Pin 4)			1	10	μA
I_H	Off Leakage at V_H	Pin 8 = 0V		1	10	μA

AC Electrical Specifications $T_A = +25^\circ\text{C}$ unless otherwise specified.

PARAMETER	DESCRIPTION	TEST CONDITIONS	MIN	TYP	MAX	UNITS
SWITCHING CHARACTERISTICS ($V_{DD} = V_H = 12\text{V}$; $V_L = -3\text{V}$)						
t_R (Note 1)	Rise Time	$C_L = 100\text{pF}$		4	25	ns
		$C_L = 2000\text{pF}$		20		ns
t_F (Note 1)	Fall Time	$C_L = 100\text{pF}$		4	25	ns
		$C_L = 2000\text{pF}$		20		ns
t_{D-1} (Note 1)	Turn-Off Delay Time	$C_L = 2000\text{pF}$		20	25	ns

AC Electrical Specifications $T_A = +25^\circ\text{C}$ unless otherwise specified. (Continued)

PARAMETER	DESCRIPTION	TEST CONDITIONS	MIN	TYP	MAX	UNITS
t_{D-2} (Note 1)	Turn-On Delay Time	$C_L = 2000\text{pF}$		10	25	ns
t_{D-1} (Note 1)	Three-State Delay				25	ns
t_{D-2} (Note 1)	Three-State Delay				25	ns

Timing Table

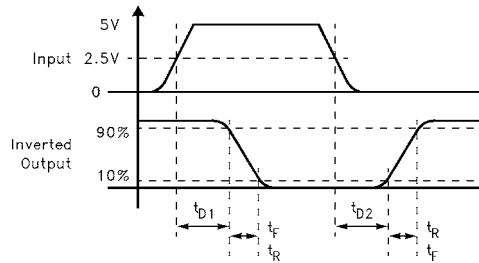

Standard Test Configuration

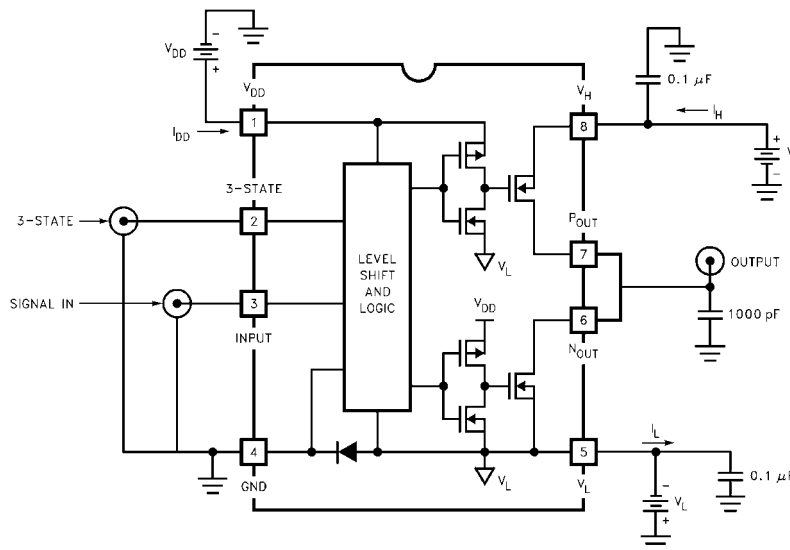

Typical Performance Curves

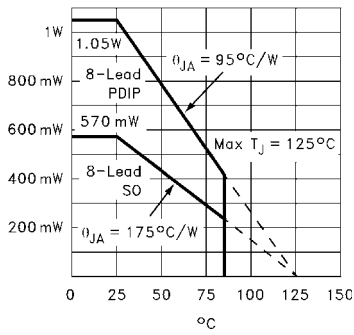

FIGURE 1. MAX POWER DERATING CURVES

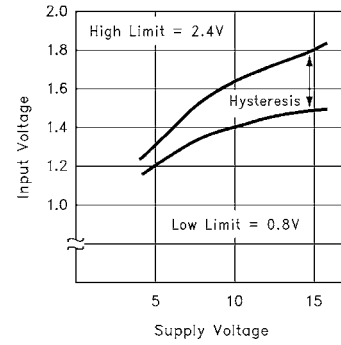

FIGURE 2. SWITCH THRESHOLD vs SUPPLY VOLTAGE

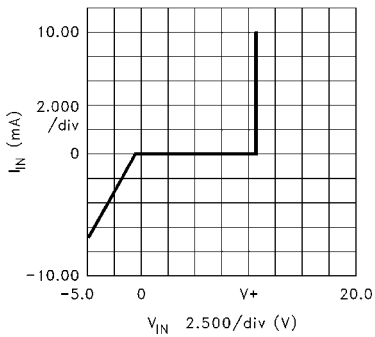

FIGURE 3. INPUT CURRENT vs VOLTAGE

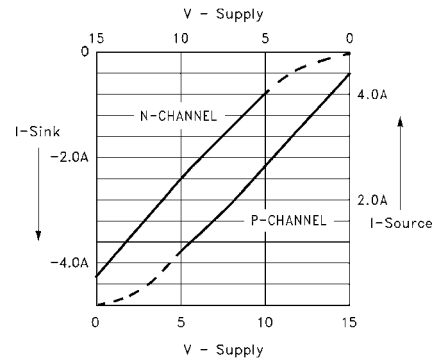

FIGURE 4. PEAK DRIVE vs SUPPLY VOLTAGE

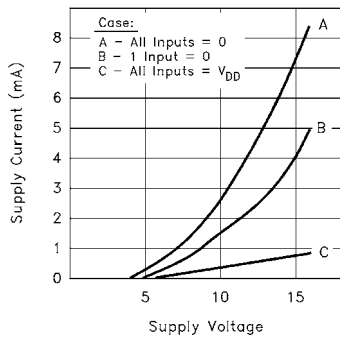

FIGURE 5. QUIESCENT SUPPLY CURRENT

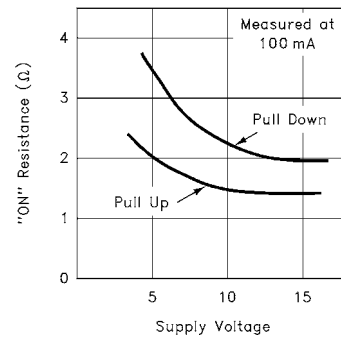

FIGURE 6. "ON" RESISTANCE vs SUPPLY VOLTAGE

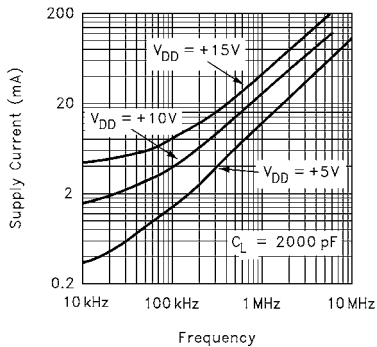

FIGURE 7. AVERAGE SUPPLY CURRENT vs VOLTAGE AND FREQUENCY

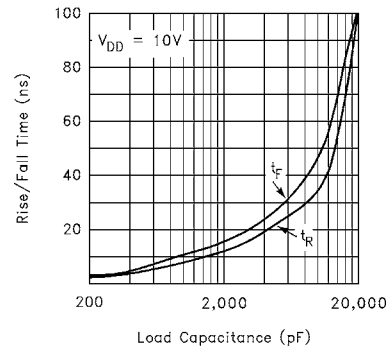

FIGURE 8. RISE/FALL TIME vs LOAD

Typical Applications

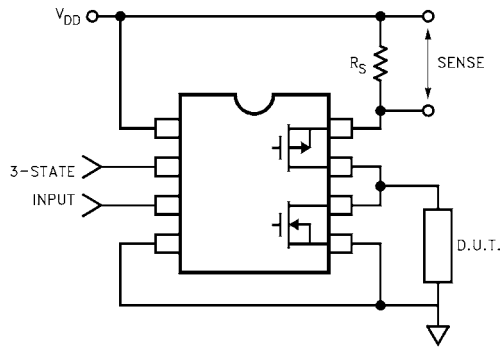

FIGURE 9. PIN DRIVER

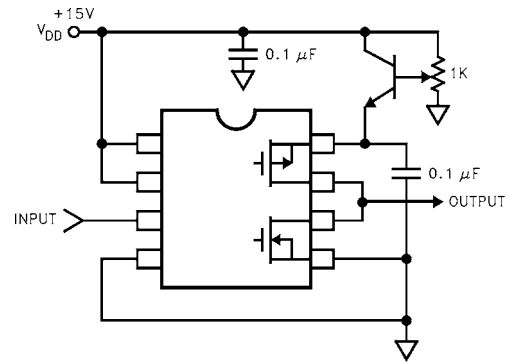

FIGURE 10. ADJUSTABLE AMPLITUDE PULSE GENERATOR

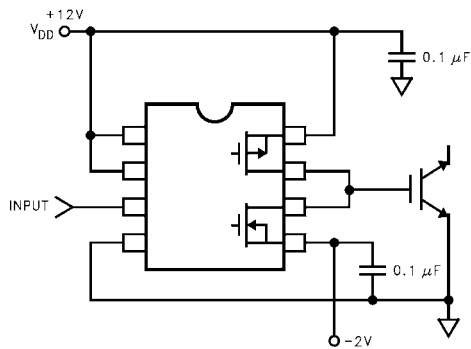

FIGURE 11. IGBT DRIVER WITH NEGATIVE SWING

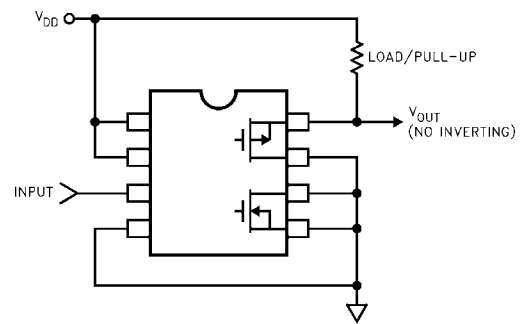

FIGURE 12. PMDS FOLLOWER

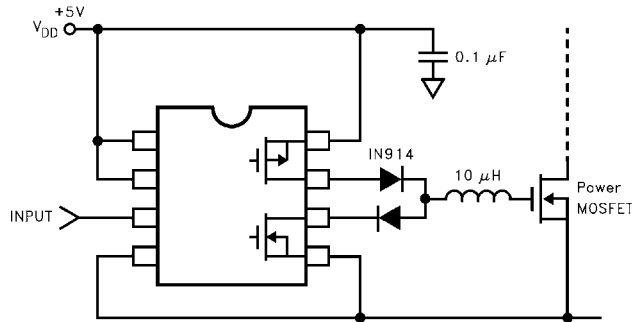
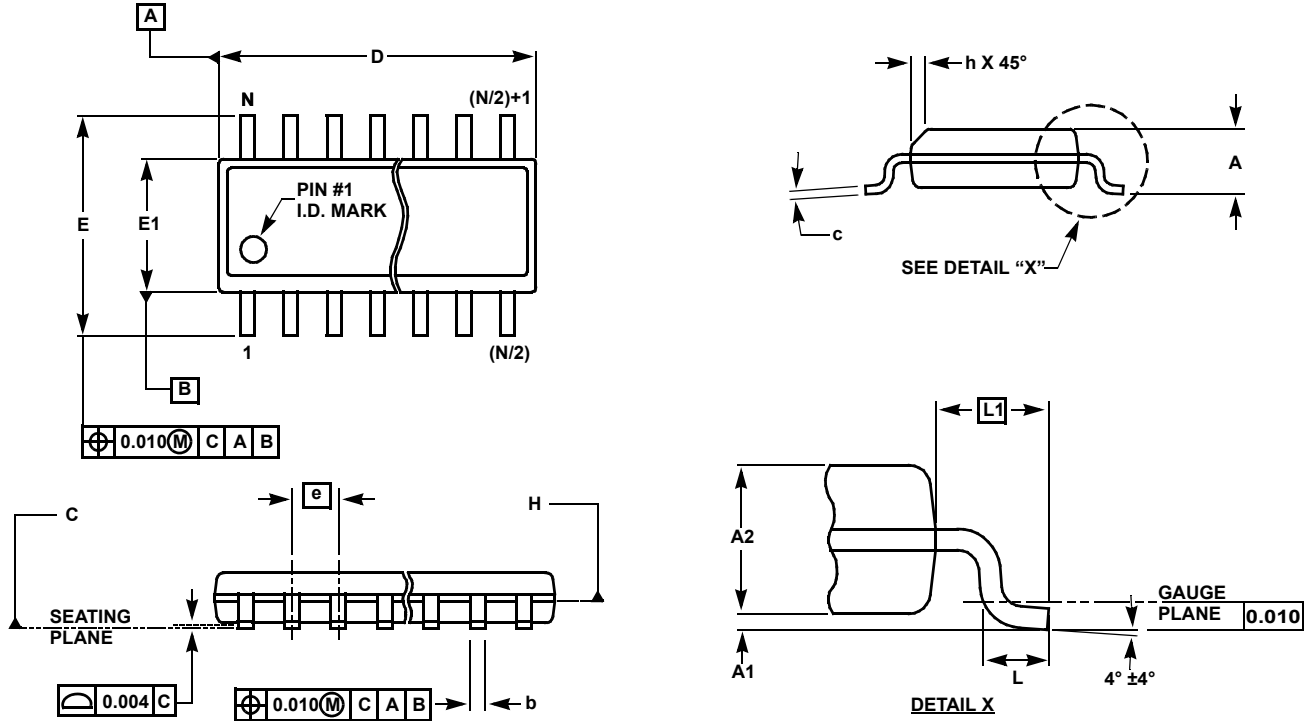

FIGURE 13. RESONANT GATE DRIVER

Small Outline Package Family (SO)



MDP0027

SMALL OUTLINE PACKAGE FAMILY (SO)

SYMBOL	INCHES							TOLERANCE	NOTES
	SO-8	SO-14	SO16 (0.150")	SO16 (0.300") (SOL-16)	SO20 (SOL-20)	SO24 (SOL-24)	SO28 (SOL-28)		
A	0.068	0.068	0.068	0.104	0.104	0.104	0.104	MAX	-
A1	0.006	0.006	0.006	0.007	0.007	0.007	0.007	±0.003	-
A2	0.057	0.057	0.057	0.092	0.092	0.092	0.092	±0.002	-
b	0.017	0.017	0.017	0.017	0.017	0.017	0.017	±0.003	-
c	0.009	0.009	0.009	0.011	0.011	0.011	0.011	±0.001	-
D	0.193	0.341	0.390	0.406	0.504	0.606	0.704	±0.004	1, 3
E	0.236	0.236	0.236	0.406	0.406	0.406	0.406	±0.008	-
E1	0.154	0.154	0.154	0.295	0.295	0.295	0.295	±0.004	2, 3
e	0.050	0.050	0.050	0.050	0.050	0.050	0.050	Basic	-
L	0.025	0.025	0.025	0.030	0.030	0.030	0.030	±0.009	-
L1	0.041	0.041	0.041	0.056	0.056	0.056	0.056	Basic	-
h	0.013	0.013	0.013	0.020	0.020	0.020	0.020	Reference	-
N	8	14	16	16	20	24	28	Reference	-

Rev. M 2/07

NOTES:

1. Plastic or metal protrusions of 0.006" maximum per side are not included.
2. Plastic interlead protrusions of 0.010" maximum per side are not included.
3. Dimensions "D" and "E1" are measured at Datum Plane "H".
4. Dimensioning and tolerancing per ASME Y14.5M-1994

Plastic Dual-In-Line Packages (PDIP)

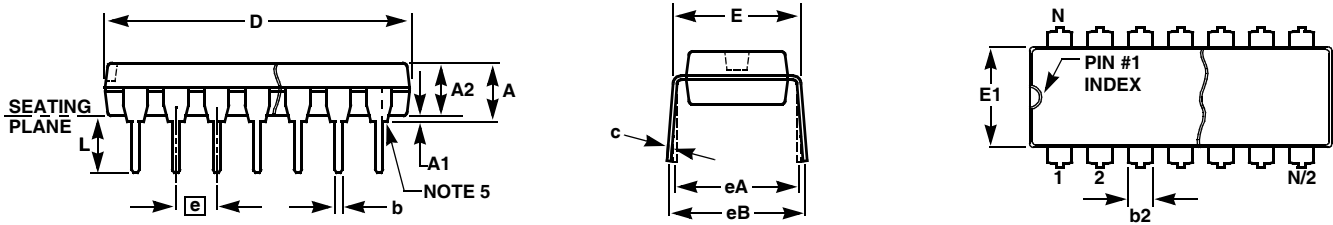

MDP0031

PLASTIC DUAL-IN-LINE PACKAGE

SYMBOL	INCHES					TOLERANCE	NOTES
	PDIP8	PDIP14	PDIP16	PDIP18	PDIP20		
A	0.210	0.210	0.210	0.210	0.210	MAX	
A1	0.015	0.015	0.015	0.015	0.015	MIN	
A2	0.130	0.130	0.130	0.130	0.130	±0.005	
b	0.018	0.018	0.018	0.018	0.018	±0.002	
b2	0.060	0.060	0.060	0.060	0.060	+0.010/-0.015	
c	0.010	0.010	0.010	0.010	0.010	+0.004/-0.002	
D	0.375	0.750	0.750	0.890	1.020	±0.010	1
E	0.310	0.310	0.310	0.310	0.310	+0.015/-0.010	
E1	0.250	0.250	0.250	0.250	0.250	±0.005	2
e	0.100	0.100	0.100	0.100	0.100	Basic	
eA	0.300	0.300	0.300	0.300	0.300	Basic	
eB	0.345	0.345	0.345	0.345	0.345	±0.025	
L	0.125	0.125	0.125	0.125	0.125	±0.010	
N	8	14	16	18	20	Reference	

Rev. C 2/07

NOTES:

1. Plastic or metal protrusions of 0.010" maximum per side are not included.
2. Plastic interlead protrusions of 0.010" maximum per side are not included.
3. Dimensions E and eA are measured with the leads constrained perpendicular to the seating plane.
4. Dimension eB is measured with the lead tips unconstrained.
5. 8 and 16 lead packages have half end-leads as shown.

All Intersil U.S. products are manufactured, assembled and tested utilizing ISO9000 quality systems. Intersil Corporation's quality certifications can be viewed at www.intersil.com/design/quality

Intersil products are sold by description only. Intersil Corporation reserves the right to make changes in circuit design, software and/or specifications at any time without notice. Accordingly, the reader is cautioned to verify that data sheets are current before placing orders. Information furnished by Intersil is believed to be accurate and reliable. However, no responsibility is assumed by Intersil or its subsidiaries for its use; nor for any infringements of patents or other rights of third parties which may result from its use. No license is granted by implication or otherwise under any patent or patent rights of Intersil or its subsidiaries.

For information regarding Intersil Corporation and its products, see www.intersil.com