

## Interface circuit (relay and Lamp-driver)

### Features

- Open ground protection
- High output current
- Adjustable short-circuit protection
- Internal thermal protection with external reset
- Large supply voltage range
- Alarm output
- Input voltage can be higher than  $V_{CC}$
- Output voltage can be lower than ground  
( $V_{CC} - V_O \leq V_{CC(max)}$ )

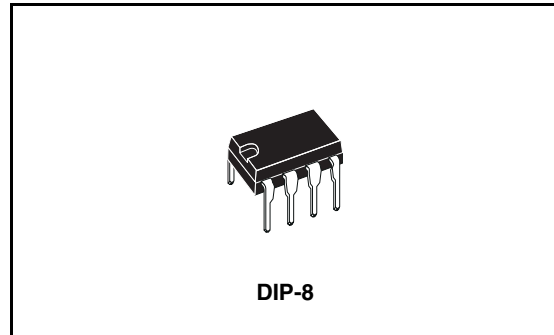

### Description

The TDE1767, TDE1767A, TDE1787, TDE1787A are a monolithic amplifiers designed for high current and high voltage applications, specifically to drive lamps, relays, stepping motors.

The devices are essentially blow-out proof. The output is protected from short-circuits with the positive supply or drive. In addition thermal shut down is provided to keep the IC from overheating.

If internal dissipation becomes too high, the driver will shut down to prevent excessive heating. The output stays null after the overheating is off, if the reset input is low. If high the output will alternatively switch-on and off until the overload is removed.

The device operates over a wide range of voltages from standard 15V operational amplifier supplies to the single +6V or +48V used for industrial electric systems. Input voltages can be higher than in the  $V_{CC}$ .

An alarm output suitable for driving a LED is provided. This LED, normally on (if referred to ground), will die out or flash during an overload depending on the state of the reset input.

The output is low in open ground conditions.

**Table 1. Device summary**

Part number	Package	Packaging
TDE1767DP	DIP8	Tube
TDE1767ADP	DIP8	Tube
TDE1787DP	DIP8	Tube
TDE1787ADP	DIP8	Tube

---

## Contents

<b>1</b>	<b>Pin connections</b> .....	<b>3</b>
<b>2</b>	<b>Maximum ratings</b> .....	<b>3</b>
	2.1 Absolute maximum ratings .....	3
	2.2 Thermal data .....	3
<b>3</b>	<b>Electrical characteristics</b> .....	<b>4</b>
<b>4</b>	<b>Schematic diagrams</b> .....	<b>6</b>
<b>5</b>	<b>Typical characteristics</b> .....	<b>7</b>
<b>6</b>	<b>Typical application</b> .....	<b>9</b>
<b>7</b>	<b>Using alarm output</b> .....	<b>11</b>
<b>8</b>	<b>Mechanical data</b> .....	<b>13</b>
<b>9</b>	<b>Revision history</b> .....	<b>15</b>

# 1 Pin connections

Figure 1. Pin connection (top view)

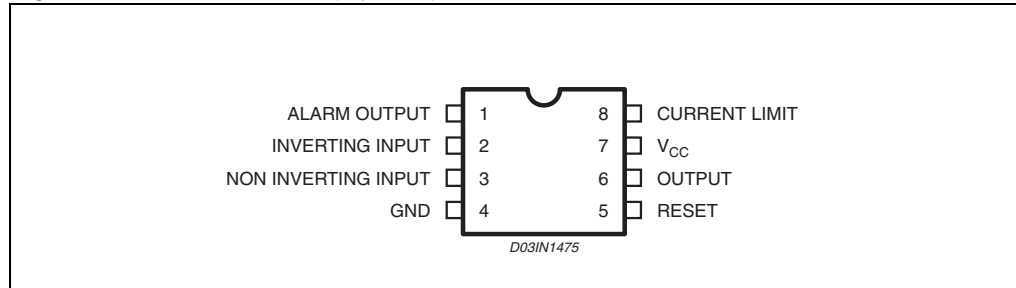

## 2 Maximum ratings

### 2.1 Absolute maximum ratings

Table 2. Absolute maximum ratings

Symbol	Parameter	TDE1767A TDE1787A	TDE1767 TDE1787	Unit
V <sub>CC</sub>	Supply voltage	60	50	V
V <sub>ID</sub>	Input differential voltage	60	50	V
V <sub>I</sub>	Input voltage	- 10 to + 60	- 10 to + 50	V
I <sub>O</sub>	Output current	1.3	1.2	A
V <sub>I(reset)</sub>	Reset input voltage	- 0.5 to + 60	- 0.5 to + 50	V
I <sub>OA</sub>	Alarm output current	- 10 to + 20	- 10 to + 20	mA
P <sub>tot</sub>	Power dissipation	Internally Limited		mW
T <sub>oper</sub>	Operating ambient temperature range	- 25 to + 85	- 25 to + 85	°C
T <sub>stg</sub>	Storage temperature range	- 65 to + 150	- 65 to + 150	°C

### 2.2 Thermal data

Table 3. Thermal data

Symbol	Parameter	Value	Unit
R <sub>th(JC)</sub>	Thermal resistance junction-case	max 30	°C/W
R <sub>th(JA)</sub>	Thermal resistance junction-ambient	max 80	°C/W

Note: Devices bonded on a 40 cm<sup>2</sup> glass-epoxy printed circuit 0.15 cm thick with 4 cm<sup>2</sup> of copper.

### 3 Electrical characteristics

**TDE1767A:** - 25°C ≤ T<sub>A</sub> ≤ 85°C, 6V ≤ V<sub>CC</sub> ≤ 55V, I<sub>o</sub> ≤ 500mA, T<sub>J</sub> ≤ 150°C

**TDE1767:** - 25°C ≤ T<sub>A</sub> ≤ 85°C, 6V ≤ V<sub>CC</sub> ≤ 45V, I<sub>o</sub> ≤ 500mA, T<sub>J</sub> ≤ 150°C

**TDE1787A:** - 25°C ≤ T<sub>A</sub> ≤ 85°C, 6V ≤ V<sub>CC</sub> ≤ 55V, I<sub>o</sub> ≤ 300mA, T<sub>J</sub> ≤ 150°C

**TDE1787:** 25°C ≤ T<sub>A</sub> ≤ 85°C, 6V ≤ V<sub>CC</sub> ≤ 45V, I<sub>o</sub> ≤ 300mA, T<sub>J</sub> ≤ 150°C

Unless otherwise specified.

**Table 4. Electrical characteristics**

Symbol	Parameter	Test condition	Min.	Typ.	Max.	Unit
V <sub>IO</sub>	Input offset voltage	(note 1)		2	50	mV
I <sub>CC</sub>	Power supply current	(measured on pin 4)				
		Output high (T <sub>A</sub> = 25°C)		5.8	8	mA
		Output high (V <sub>CC</sub> = V <sub>CCmax</sub> , (T <sub>J</sub> = 150°C)		5	7	mA
		Output low (V <sub>CC</sub> = V <sub>CCmax</sub> , (T <sub>A</sub> = 25°C)		1.5	4	mA
I <sub>IB</sub>	Input bias current		15	100	μA	
V <sub>CM</sub>	Common-mode input voltage range	TDE1787A, TDE1767A	1		60	V
		TDE1787, TDE1767	1		45	V
V <sub>I</sub>	Input voltage range	V <sub>ref</sub> ≥ 1V (figure1, note2)				
		TDE1787A, TDE1767A TDE1787, TDE1767	1 1		60 45	V V
I <sub>SC</sub>	Short circuit output current	V <sub>CC</sub> = 35V, t = 10ms				
		<b>TDE1767A:</b> R <sub>SC</sub> = 0.22Ω <b>TDE1787A:</b> R <sub>SC</sub> = 0.33Ω		700 380		mA mA
V <sub>sense</sub>	Output limit sense voltage	V <sub>O</sub> = V <sub>CC</sub> - 2V, t = 10ms	130	150	170	mV
V <sub>sense</sub>	Output limit sense voltage	V <sub>O</sub> = 0V, t = 10ms	120	140	165	mV
V <sub>O(sat)</sub>	Output saturation voltage	Output high V <sub>I</sub> <sup>+</sup> - V <sub>I</sub> <sup>-</sup> ≥ 50mV; R <sub>SC</sub> = 0; V <sub>CC</sub> = 30V TDE1787A, TDE1767A: T <sub>J</sub> = 25°C		1	1.1	V
		TDE1787, TDE1767: T <sub>J</sub> = 25°C		1	1.2	V
		TDE1787A, TDE1767A: T <sub>J</sub> = 150°C		1.1	1.2	V
		TDE1787, TDE1767: T <sub>J</sub> = 150°C		1.1	1.3	V
I <sub>OL</sub>	Output leakage current	Output low			100	μA

**Table 4. Electrical characteristics (continued)**

Symbol	Parameter	Test condition	Min.	Typ.	Max.	Unit
$I_A$	Available alarm output current	Output source current $V_{AH} = V_{CC} - 2.5V$	-4	-5		mA
		Output sink current (in thermal shut-down) $V_A = 1.4V$	5	10		mA
$I_{reset}$	Reset input current			2	40	$\mu A$
$V_{th-reset}$	Reset threshold			1.4		A
	Output leakage current	open ground		10		$\mu A$

- Note: 1 The offset voltage given is the maximum value of different input voltage required to drive the output voltage within 2 V of the ground or the supply voltage.
- 2 Input voltage range is independent of the supply voltage.

# 4 Schematic diagrams

Figure 2. Schematic diagram

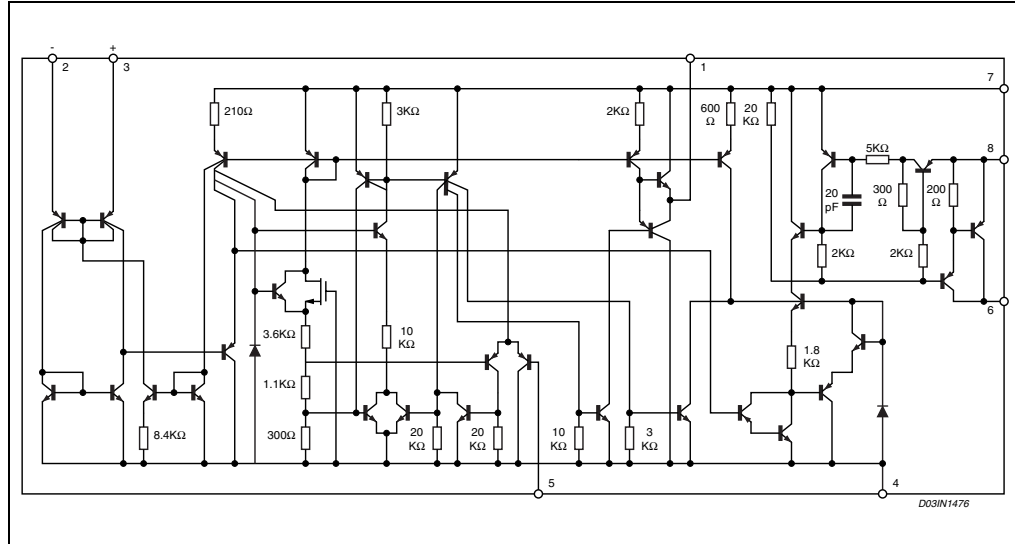
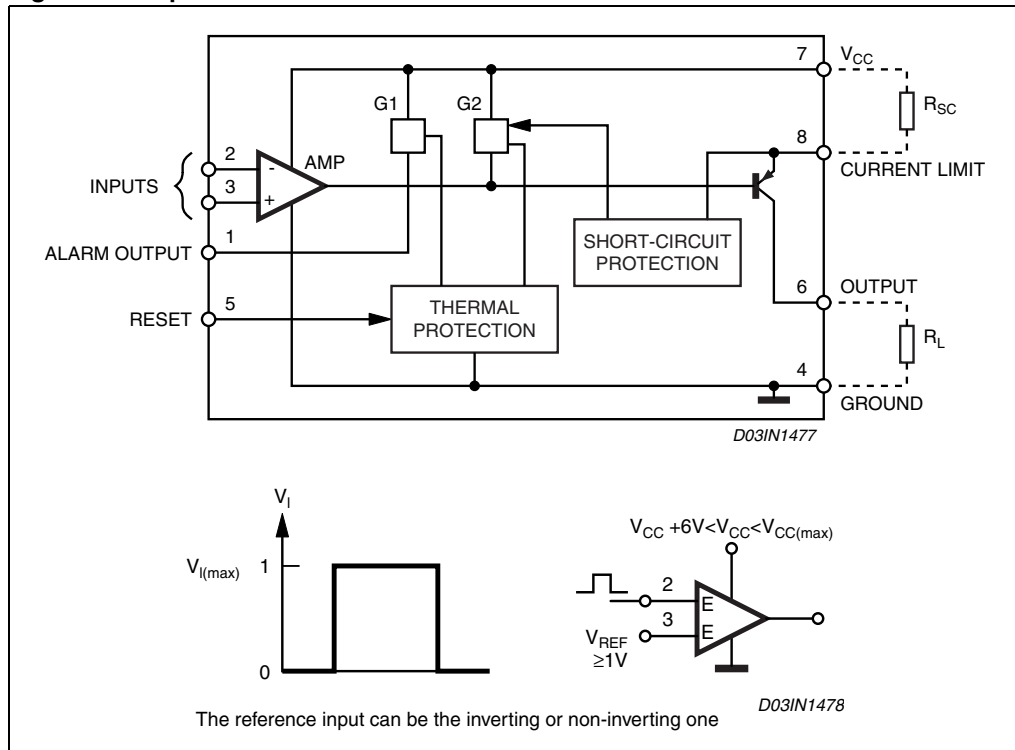
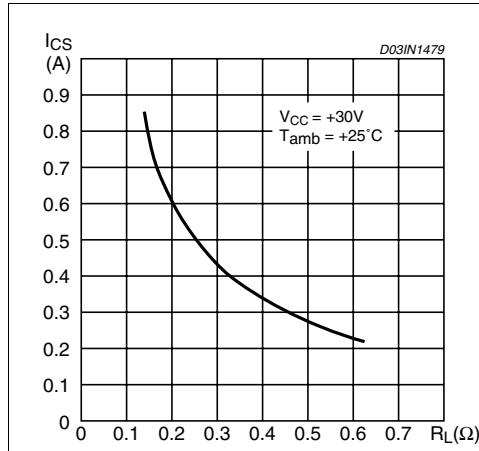

Figure 3. Equivalent schematic



## 5 Typical characteristics

**Figure 4. Peak short-circuit vs limiting resistor**



**Figure 5. Available output current vs limiting resistor**

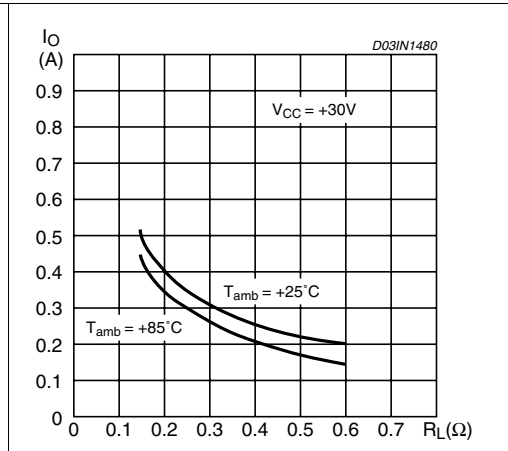

**Figure 6. Power supply current (pin 4)**

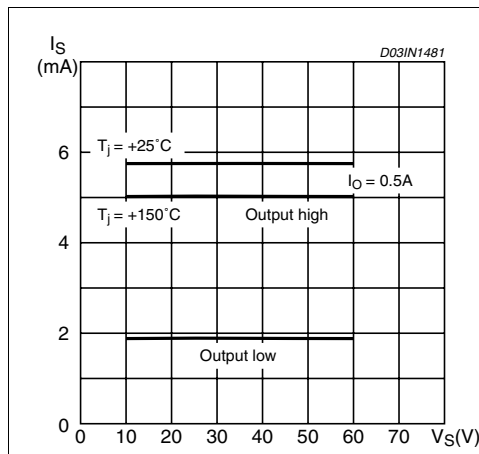

**Figure 7. Output saturation voltage vs output current**

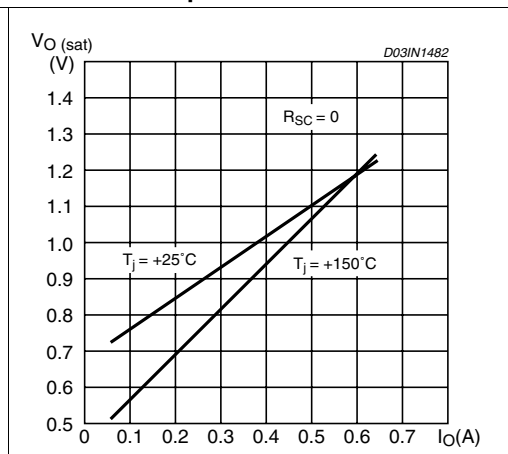

**Figure 8. Output transistor safe operating area (pulsed)**

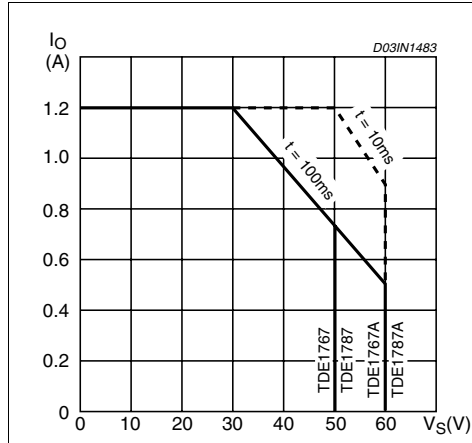

**Figure 9. Normal operating area (short circuit protected)**

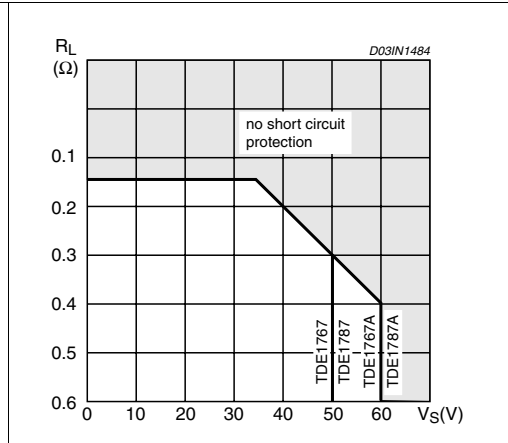

**Figure 10. Current sinking**

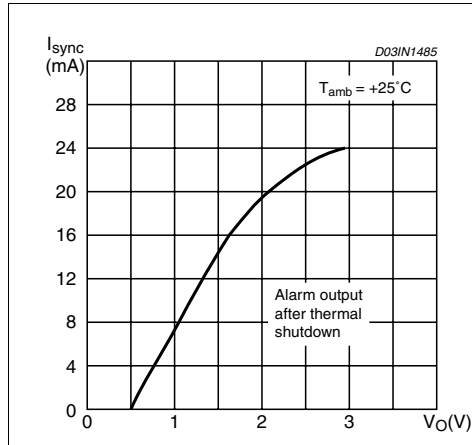

**Figure 11. Current sourcing**

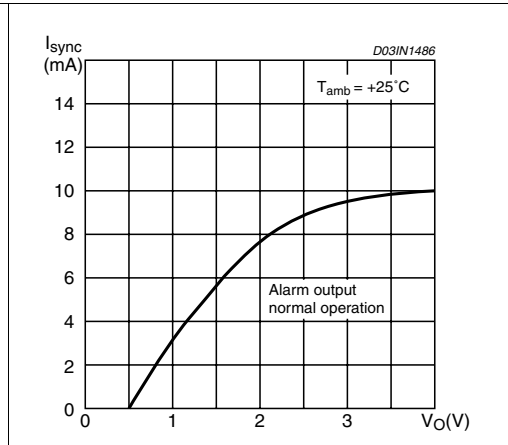

**Figure 12. Response time**

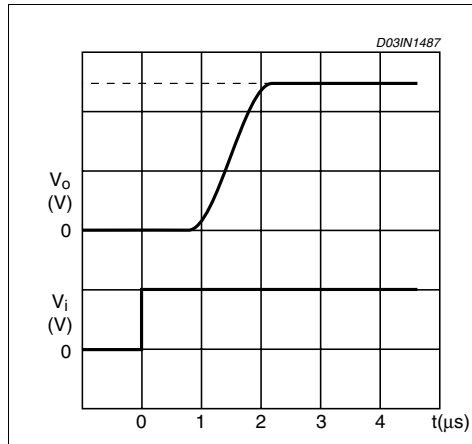

**Figure 13. Response time**

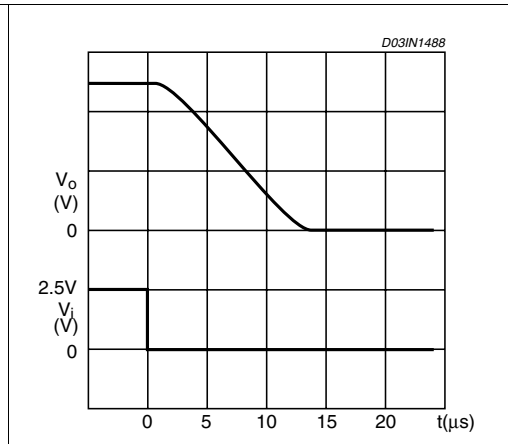



## 6 Typical application

Figure 14. Test circuit

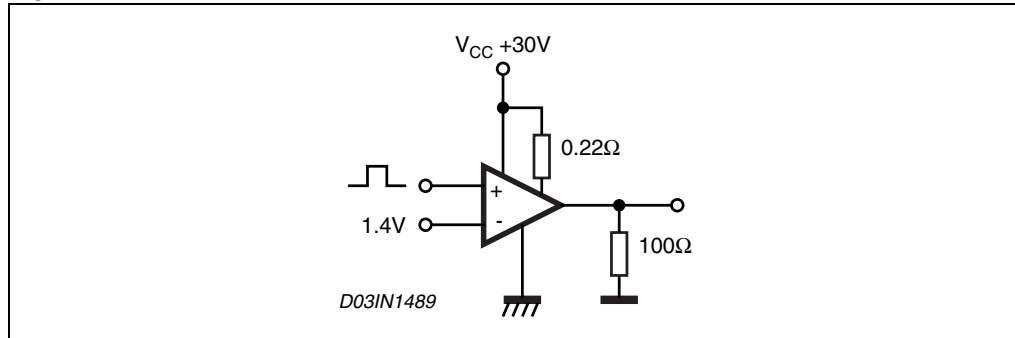

Figure 15. Open load detection.4

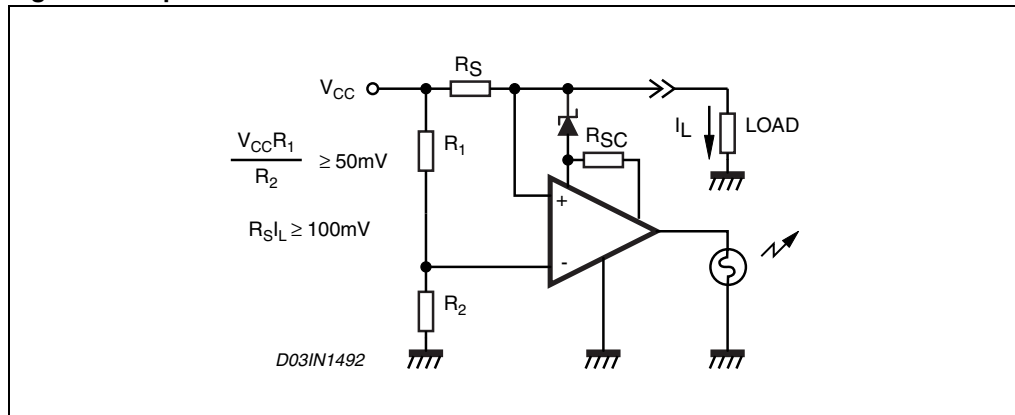

Figure 16. Driving lamps, relays, etc...

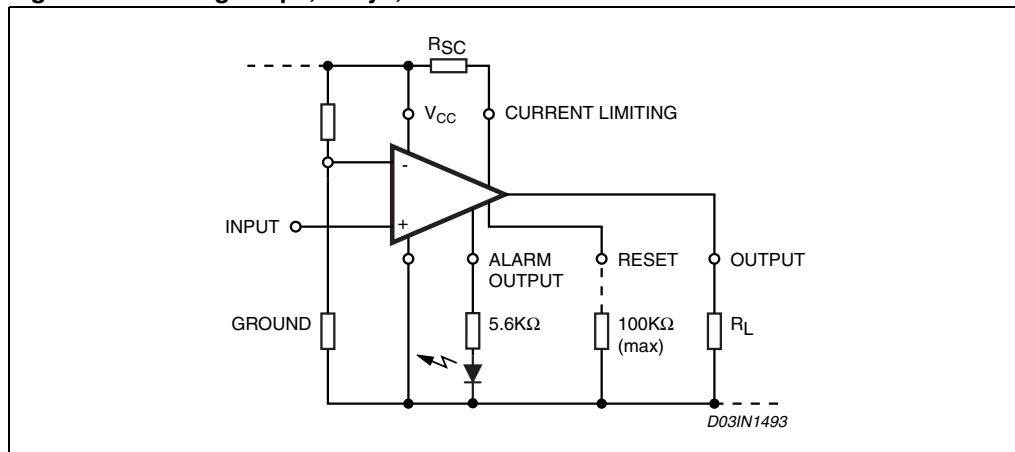

Figure 17. Common reset.

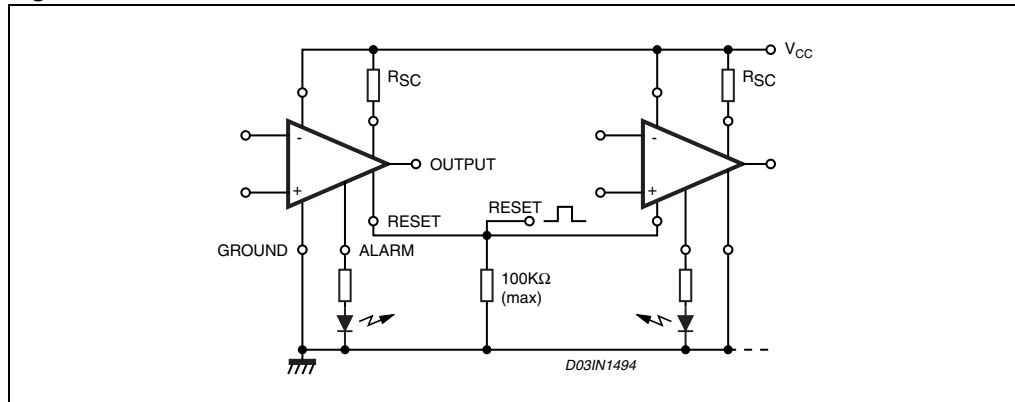
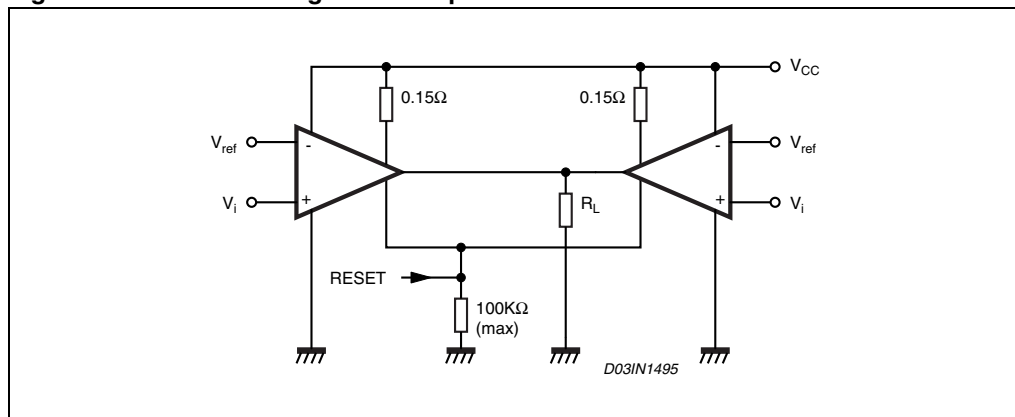

Figure 18. Parallel driving of loads up to 1 A.



## 7 Using alarm output

Figure 19. Parallel alarm output

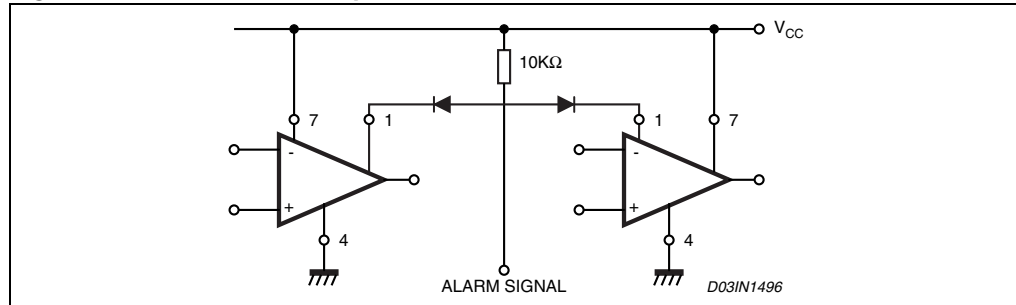

Figure 20. LED to VCC

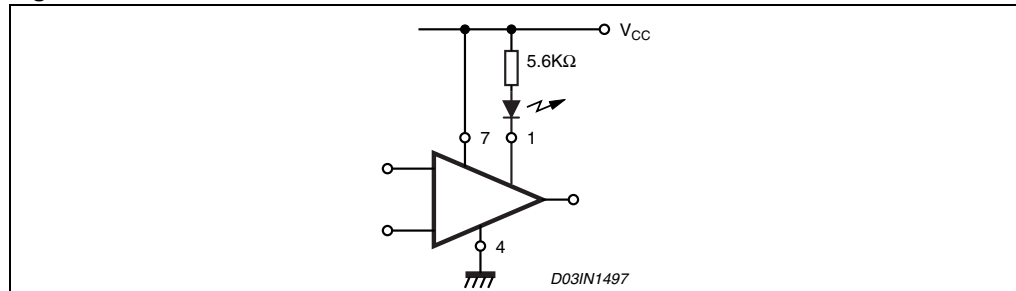
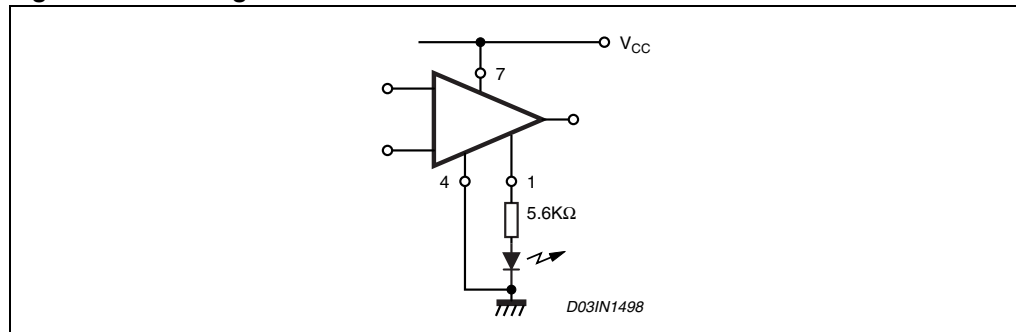
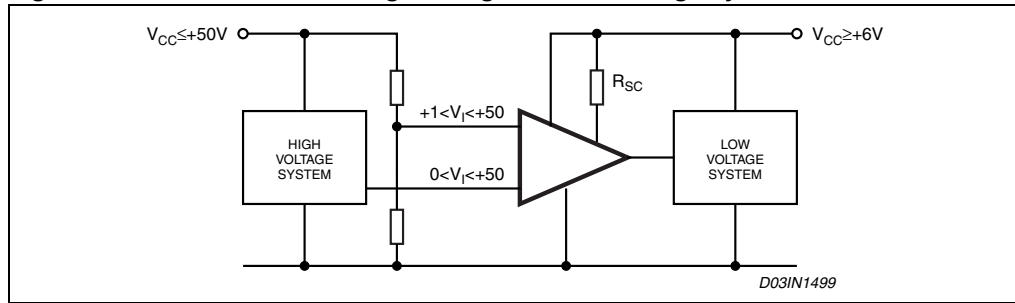

Figure 21. LED to ground



**Figure 22. Interface between high voltage and low voltage system.**



**Figure 23. Increasing current up to 10A.**

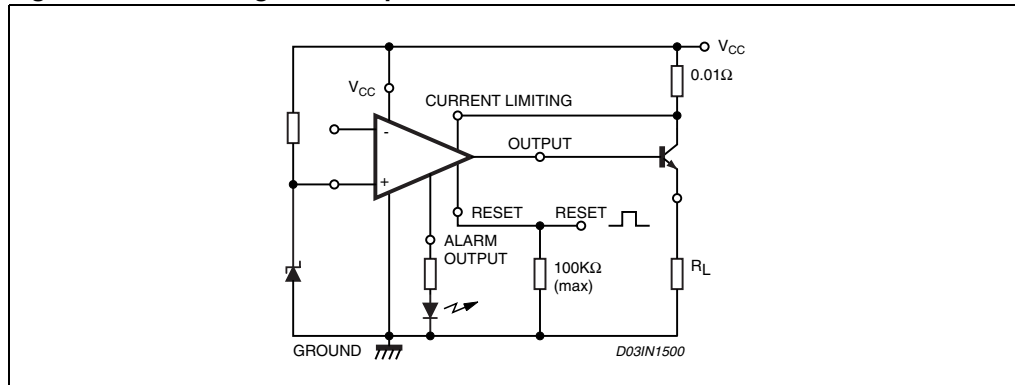

## 8 Mechanical data

In order to meet environmental requirements, ST offers these devices in ECOPACK<sup>®</sup> packages. These packages have a Lead-free second level interconnect. The category of second Level Interconnect is marked on the package and on the inner box label, in compliance with JEDEC Standard JESD97. The maximum ratings related to soldering conditions are also marked on the inner box label. ECOPACK is an ST trademark. ECOPACK specifications are available at: [www.st.com](http://www.st.com).

Table 5. DIP-8 Mechanical data

Dim.	mm			Inch		
	Min	Typ	Max	Min	Typ	Max
A		3.32			0.131	
a1	0.51			0.020		
B	1.15		1.65	0.045		0.065
b	0.356		0.55	0.014		0.022
b1	0.204		0.304	0.008		0.012
D			10.92			0.430
E	7.95		9.75	0.313		0.384
e		2.54			0.100	
e3		7.62			0.300	
e4		7.62			0.300	
F			6.6			0.260
l			5.08			0.200
L	3.18		3.81	0.125		0.150
Z			1.52			0.060

Figure 24. Package dimensions

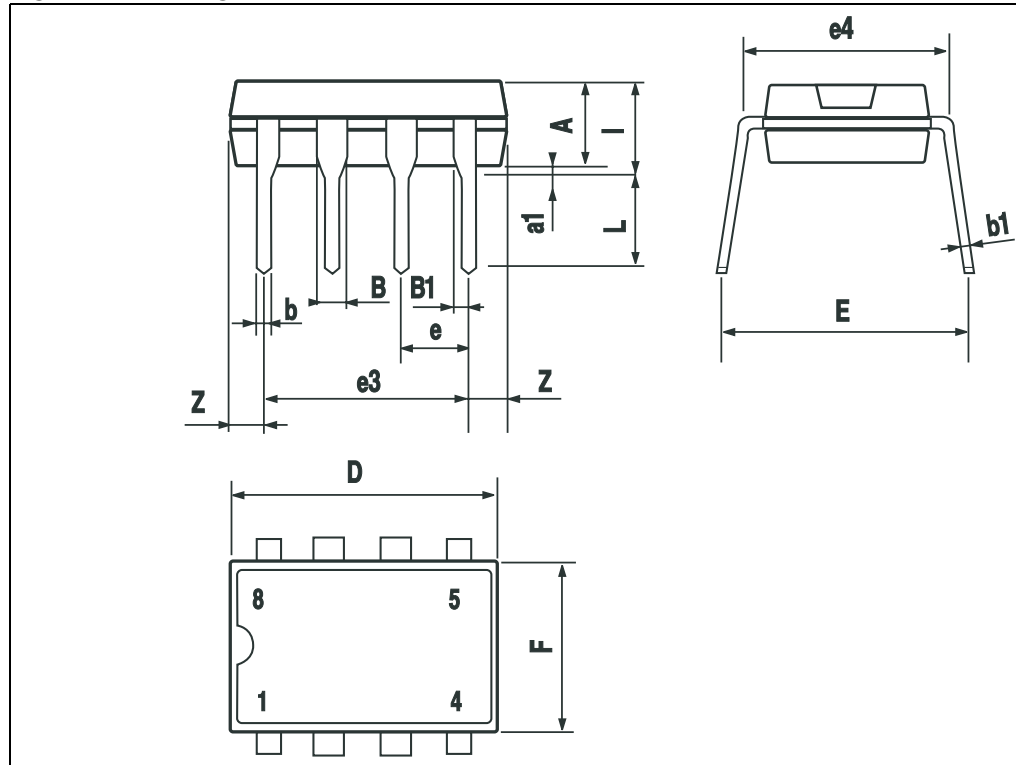

## 9 Revision history

Table 6. Revision history

Date	Revision	Changes
20-Sep-2003	1	Initial release.
3-Mar-2007	2	Document reformatted, typo <a href="#">Figure 1 on page 3</a>

**Please Read Carefully:**

Information in this document is provided solely in connection with ST products. STMicroelectronics NV and its subsidiaries ("ST") reserve the right to make changes, corrections, modifications or improvements, to this document, and the products and services described herein at any time, without notice.

All ST products are sold pursuant to ST's terms and conditions of sale.

Purchasers are solely responsible for the choice, selection and use of the ST products and services described herein, and ST assumes no liability whatsoever relating to the choice, selection or use of the ST products and services described herein.

No license, express or implied, by estoppel or otherwise, to any intellectual property rights is granted under this document. If any part of this document refers to any third party products or services it shall not be deemed a license grant by ST for the use of such third party products or services, or any intellectual property contained therein or considered as a warranty covering the use in any manner whatsoever of such third party products or services or any intellectual property contained therein.

**UNLESS OTHERWISE SET FORTH IN ST'S TERMS AND CONDITIONS OF SALE ST DISCLAIMS ANY EXPRESS OR IMPLIED WARRANTY WITH RESPECT TO THE USE AND/OR SALE OF ST PRODUCTS INCLUDING WITHOUT LIMITATION IMPLIED WARRANTIES OF MERCHANTABILITY, FITNESS FOR A PARTICULAR PURPOSE (AND THEIR EQUIVALENTS UNDER THE LAWS OF ANY JURISDICTION), OR INFRINGEMENT OF ANY PATENT, COPYRIGHT OR OTHER INTELLECTUAL PROPERTY RIGHT.**

**UNLESS EXPRESSLY APPROVED IN WRITING BY AN AUTHORIZED ST REPRESENTATIVE, ST PRODUCTS ARE NOT RECOMMENDED, AUTHORIZED OR WARRANTED FOR USE IN MILITARY, AIR CRAFT, SPACE, LIFE SAVING, OR LIFE SUSTAINING APPLICATIONS, NOR IN PRODUCTS OR SYSTEMS WHERE FAILURE OR MALFUNCTION MAY RESULT IN PERSONAL INJURY, DEATH, OR SEVERE PROPERTY OR ENVIRONMENTAL DAMAGE. ST PRODUCTS WHICH ARE NOT SPECIFIED AS "AUTOMOTIVE GRADE" MAY ONLY BE USED IN AUTOMOTIVE APPLICATIONS AT USER'S OWN RISK.**

Resale of ST products with provisions different from the statements and/or technical features set forth in this document shall immediately void any warranty granted by ST for the ST product or service described herein and shall not create or extend in any manner whatsoever, any liability of ST.

ST and the ST logo are trademarks or registered trademarks of ST in various countries.

Information in this document supersedes and replaces all information previously supplied.

The ST logo is a registered trademark of STMicroelectronics. All other names are the property of their respective owners.

© 2007 STMicroelectronics - All rights reserved

STMicroelectronics group of companies

Australia - Belgium - Brazil - Canada - China - Czech Republic - Finland - France - Germany - Hong Kong - India - Israel - Italy - Japan - Malaysia - Malta - Morocco - Singapore - Spain - Sweden - Switzerland - United Kingdom - United States of America

[www.st.com](http://www.st.com)