

INTELLIGENT POWER SWITCH

PRODUCT PREVIEW

- 0.5A OUTPUT CURRENT
- LOW SIDE OR HIGH SIDE SWITCH CONFIGURATION
- 6V TO 48V SUPPLY VOLTAGE RANGE
- OVERLOAD AND SHORT CIRCUIT PROTECTIONS
- INTERNAL VOLTAGE CLAMPING
- SUPPLY AND OUTPUT REVERSAL PROTECTION
- THERMAL SHUTDOWN
- GND AND V_S OPEN WIRE PROTECTION
- ADJUSTABLE DELAY AT SWITCH ON
- INDICATOR STATUS LED DRIVER
- +5V REGULATED AUX. VOLTAGE
- HIGH BURST IMMUNITY

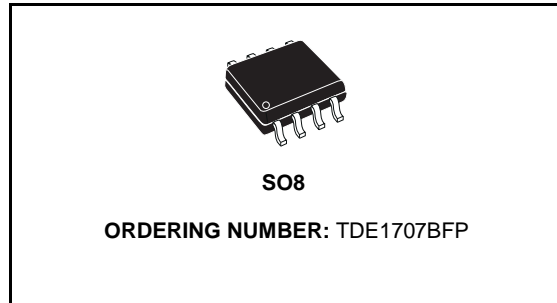

ternal +5V supply can be used to supply external circuits (See also AN495/0692). A signal is internally generated to block the In signal, and prevent activation of the output switch, as long as an abnormal condition is detected. The power-on transition, as well as the chip overtemperature and the output overcurrent, concur to the generation of such signal. A minimum delay of 25 μ s (Typ. value) is added to the trailing edge of such signal to ensure that a stable normal situation is present when the signal disappears. The delay (of the disappearance of the block signal; no delay at its on set) can be further increased connecting a capacitor between pin3 and ground.

DESCRIPTION

The TDE1707BFP is a 0.5A Integrated Power Switch with up to 48V Power supply capability.

Two output configurations are possible:

- Load to Gnd. (High Side Mode)
- Load to V_S (Low side Mode)

Especially dedicated to proximity detectors, its in-

BLOCK DIAGRAM

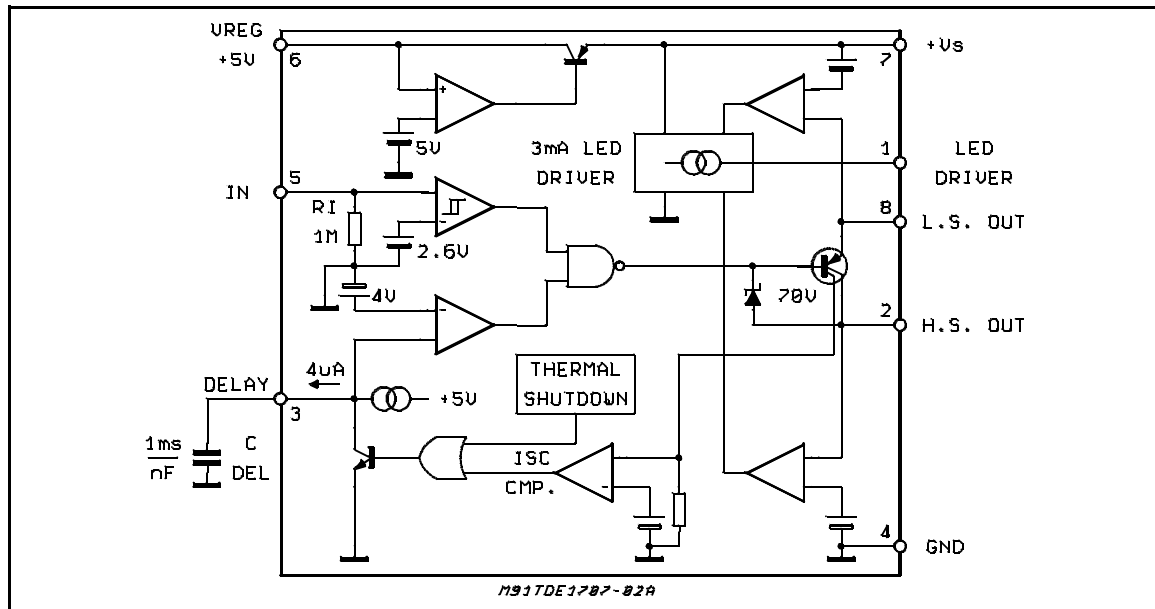

TDE1707BFP

PIN CONNECTION (Top view)

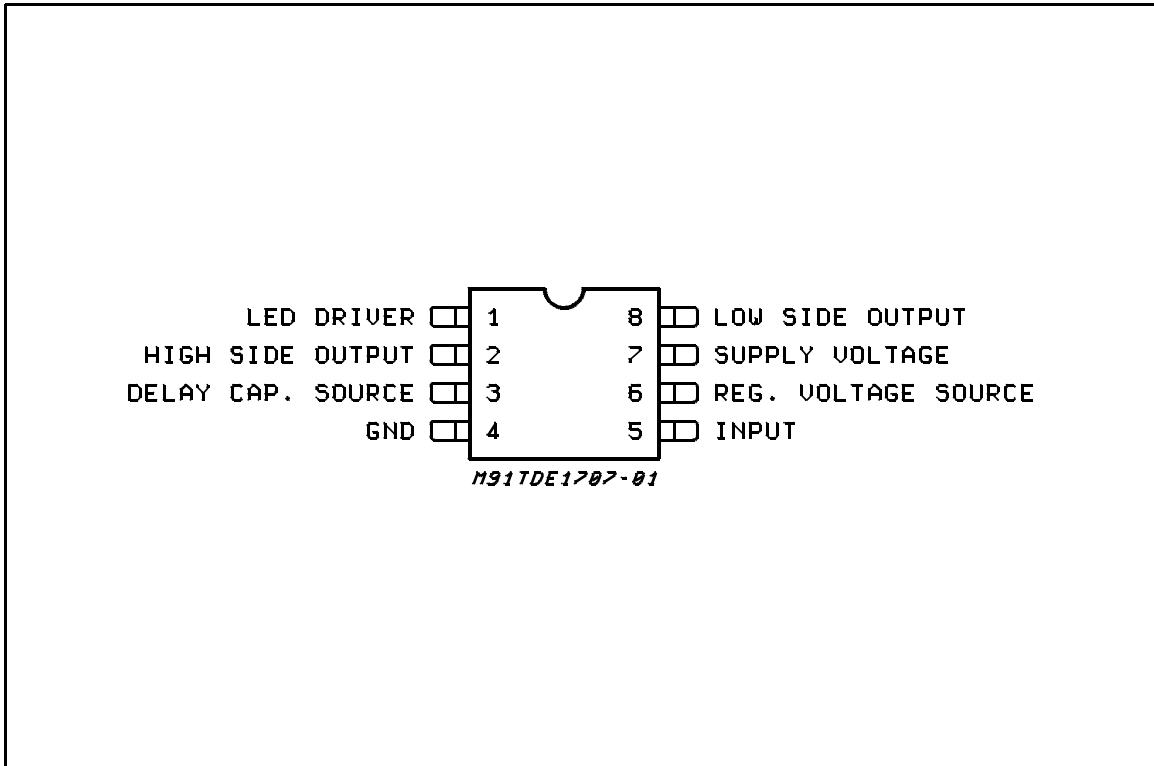

ABSOLUTE MAXIMUM RATINGS

Symbol	Parameter	Value	Unit
V_S	Supply Voltage	50	V
V_{Sr}	Supply Reverse Voltage	50	V
I_O	Output Current	internally limited	A
V_{reg}	Regulated Voltage Pin	0 to 7	V
V_{delay}	Delay Cap. Surce Pin	0 to 5	V
V_O	Output Diff. Voltage	55	V
V_i	Input Voltage	-10 to 50	V
T_{op}	Operating Temperature Range	-25 to +85	°C
T_{stg}	Storage Temperature	-55 to 150	°C
P_{tot}	Power Dissipation	internally limited	W
E_i	Energy Induct. Load	150	mJ

THERMAL DATA

Symbol	Description	Value	Unit
$R_{th\ j-amb}$	Thermal Resistance Junction-ambient	Max. 150	°C/W

ELECTRICAL CHARACTERISTICS ($V_S = 24V$; $T_J = -25$ to $+85^\circ C$, unless otherwise specified)

Symbol	Parameter	Test Condition	Min.	Typ.	Max.	Unit
V_S 7	Supply Voltage		6		48	V
I_{SR} 7	Supply Reverse Current	$V_{SR} = -48V$			1.5	mA
I_q 7	Quiescent Current	$I_{reg} = I_{led} = 0$; $V_i < 2V$; $V_S = 6$ to $48V$			1.5	mA
I_o 8/2	Output Current	$V_S = 6V$ to $32V$			500	mA
I_o 8/2	Output Current	$V_S = 32V$ to $48V$			300	mA
V_{sat} 8/2	Output Voltage Drop V_{8-2}	$I_o = 500mA$		1.1	1.6	V
V_{sat} 8/2	Output Voltage Drop V_{8-2}	$I_o = 300mA$			1.5	V
I_{sc} 8/2	Short Circuit Current		0.7		1.5	A
V_{cl} 8/2	Internal Voltage Clamp	$I_{CL} = 10mA$	55		70	V
I_{olk} 8/2	Output Leakage	(Pin 2) $V_i < 2V$; $V_o = 0$ to V_S (Pin 8)		100	300 100	μA μA
V_{ith} 5	Input Voltage Threshold		2		3	V
V_{ihis} 5	Input Threshold Hysteresis			300		mV
I_{lk} 5	Input Current	$V_i = 5V$		2	5	μA
V_{reg} 6	Regulated Output Voltage	$I_{reg} < 5mA$	4.5	5	5.5	V
I_{scr} 6	Short Circuit Regulated		6	30	50	mA
I_{reg} 6	Output Regulator Current	$V_S = 35V$ $V_S = 48V$			6 4	mA mA
I_{old} 1	Current Surce Sink Led Driver	Output ON (\pm)	2	3	4	mA
V_{old} 1	Voltage Drop Led Driver	$I_{os} = 2mA$ (\pm)		1.2	1.6	V
I_{oldk} 1	Lead Driver (off) Leak.	$V_i < 2V$; $R_L < 1K\Omega$			10	μA
I_{dch} 3	Del. Cap. Charge Current	$T_J = 25^\circ C$	2	4	6	μA
V_{dth} 3	Delay Voltage Trigger	$T_J = 25^\circ C$		4		V

APPLICATION INFORMATION (See Application Circuit)

The LED driver tells the output status. It can source or sink current ($I_{old\ typ} = 3mA$), according to the output configuration chosen. The thresholds, represented by the output comparator in the Block Diagram, are set at about 1.5V - 2V. For instance, in the High Side Load case of the

Application Circuit, when the voltage on pin 8 (the output) differs from V_{CC} less than 1.5V, the output is sensed in "OFF" state and the LED driver is disabled.

If instead pin 8 differs from V_{CC} more than 3V (the output comparator threshold value plus the drop voltage on the LED), then the output is sensed "ON" and the driver will force the current on the LED.

DYNAMIC CHARACTERISTICS ($V_S = 24V$; $R_L = 48\Omega$; $T_J = 25^\circ C$)

t_{on}	Propagation Turn on Time	$V_i = 0$ to $5V$		15		μs
t_{off}	Propagation Turn off Time	$V_i = 5$ to $0V$		15		μs
t_{don}	Delayed Turn on Time / nF Delay Capacitor		0.65	1	2	ms
$t_{d\ min}$	Minimum Delayed t_{on} Delay Capacitor = 0			25		μs

APPLICATION CIRCUIT

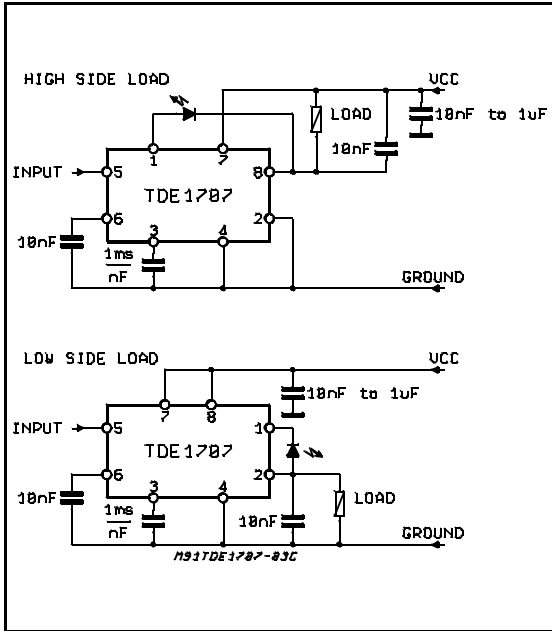

Figure 1: Input Thresholds Voltage vs. Temperature ($V_S = 24V$)

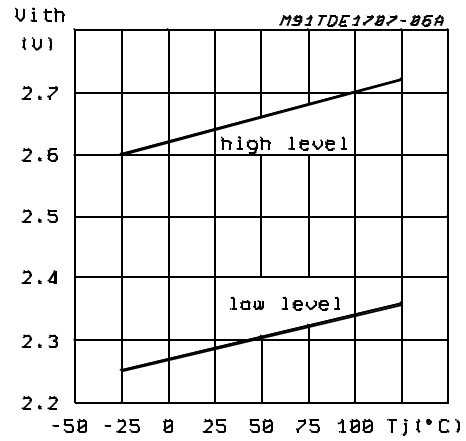

Figure 2: Saturation Voltage vs. Temperature ($V_S = 24V$; $I_o = 500mA$)

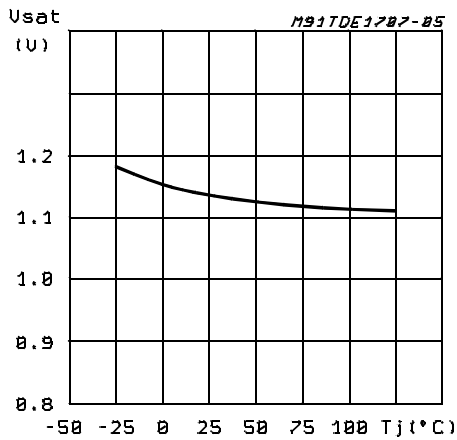
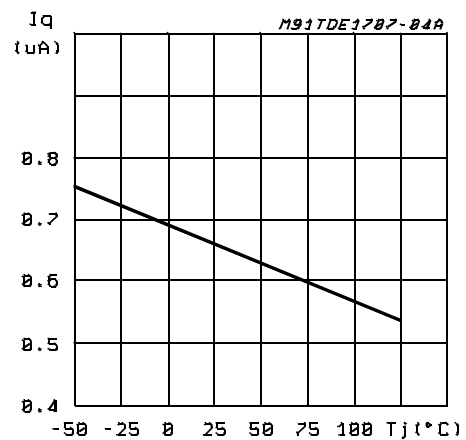
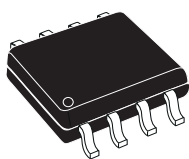

Figure 3: Quiescent Current (I_q) vs. Temperature ($V_S = 24V$)



DIM.	mm			inch		
	MIN.	TYP.	MAX.	MIN.	TYP.	MAX.
A			1.75			0.069
a1	0.1		0.25	0.004		0.010
a2			1.65			0.065
a3	0.65		0.85	0.026		0.033
b	0.35		0.48	0.014		0.019
b1	0.19		0.25	0.007		0.010
C	0.25		0.5	0.010		0.020
c1	45° (typ.)					
D (1)	4.8		5.0	0.189		0.197
E	5.8		6.2	0.228		0.244
e		1.27			0.050	
e3		3.81			0.150	
F (1)	3.8		4.0	0.15		0.157
L	0.4		1.27	0.016		0.050
M			0.6			0.024
S	8° (max.)					

OUTLINE AND MECHANICAL DATA



SO8

(1) D and F do not include mold flash or protrusions. Mold flash or protrusions shall not exceed 0.15mm (.006inch).

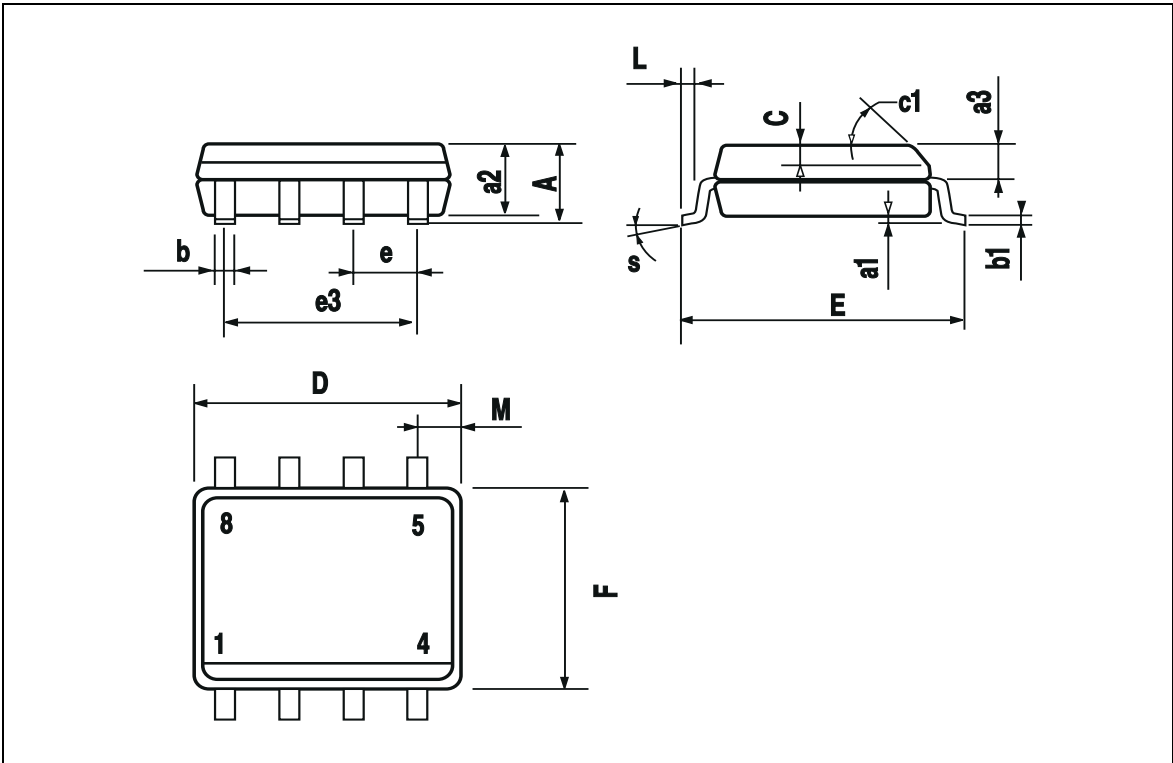

Information furnished is believed to be accurate and reliable. However, STMicroelectronics assumes no responsibility for the consequences of use of such information nor for any infringement of patents or other rights of third parties which may result from its use. No license is granted by implication or otherwise under any patent or patent rights of STMicroelectronics. Specifications mentioned in this publication are subject to change without notice. This publication supersedes and replaces all information previously supplied. STMicroelectronics products are not authorized for use as critical components in life support devices or systems without express written approval of STMicroelectronics.

The ST logo is a registered trademark of STMicroelectronics.
All other names are the property of their respective owners

© 2003 STMicroelectronics - All rights reserved

STMicroelectronics GROUP OF COMPANIES

Australia - Belgium - Brazil - Canada - China - Czech Republic - Finland - France - Germany - Hong Kong - India - Israel - Italy - Japan -
Malaysia - Malta - Morocco - Singapore - Spain - Sweden - Switzerland - United Kingdom - United States

www.st.com

