



VNQ860 VNQ860SP

QUAD CHANNEL HIGH SIDE DRIVER

TYPE	$R_{DS(on)}$ (*)	I_{OUT}	V_{CC}
VNQ860	270m Ω	0.25A	36V
VNQ860SP			

(*) Per each channel

- CMOS COMPATIBLE I/Os
- UNDERVOLTAGE & OVERVOLTAGE SHUT-DOWN
- SHORTED LOAD PROTECTION
- THERMAL SHUTDOWN
- VERY LOW STAND-BY CURRENT
- PROTECTION AGAINST LOSS OF GROUND

DESCRIPTION

The VNQ860, VNQ860SP are monolithic devices made using STMicroelectronics VIPower M0-3 Technology, intended for driving any kind load with one side connected to ground. Active current limitation combined with thermal shutdown and automatic restart protect the device against overload. Device automatically turns off in case of ground pin disconnection. This device is

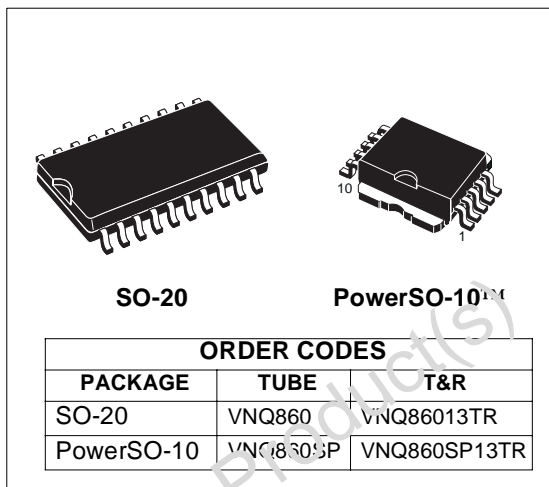

especially suitable for industrial applications in norms conformity with IEC1131 (Programmable Controllers International Standard).

BLOCK DIAGRAM

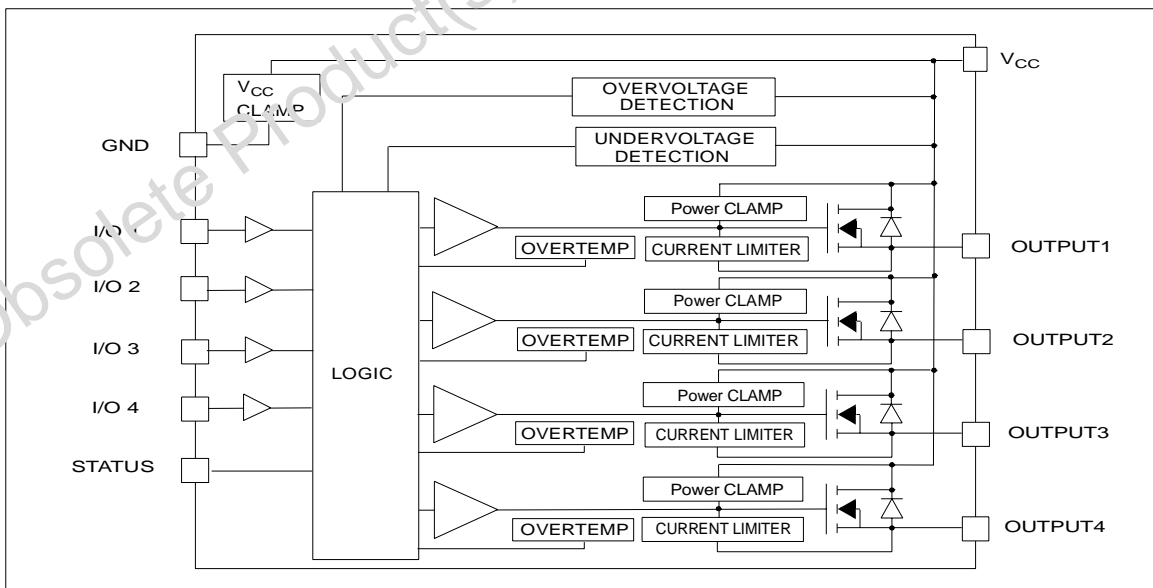

Rev. 1

ABSOLUTE MAXIMUM RATING

Symbol	Parameter	Value		Unit
		SO-20	PowerSO-10	
V_{CC}	DC supply voltage	41		V
$-V_{CC}$	Reverse DC supply voltage	- 0.3		V
$-I_{GND}$	DC reverse ground pin current	- 200		mA
I_{OUT}	DC output current	Internally Limited		A
$-I_{OUT}$	Reverse DC output current	- 2		A
I_{IN}	DC Input current	+/- 10		mA
V_{IN}	Input voltage range	$-3/+V_{CC}$		V
V_{STAT}	DC Status voltage	$+ V_{CC}$		V
V_{ESD}	Electrostatic discharge (R=1.5 K Ω ; C=100 pF)	2000		V
P_{tot}	Power dissipation $T_C=25^\circ C$	16	90	W
T_j	Junction operating temperature	Internally Limited		$^\circ C$
T_c	Case operating temperature	- 40 to 150		$^\circ C$
T_{stg}	Storage temperature	- 55 to 150		$^\circ C$

CONFIGURATION DIAGRAM (TOP VIEW) & SUGGESTED CONNECTIONS FOR UNUSED AND N.C. PINS

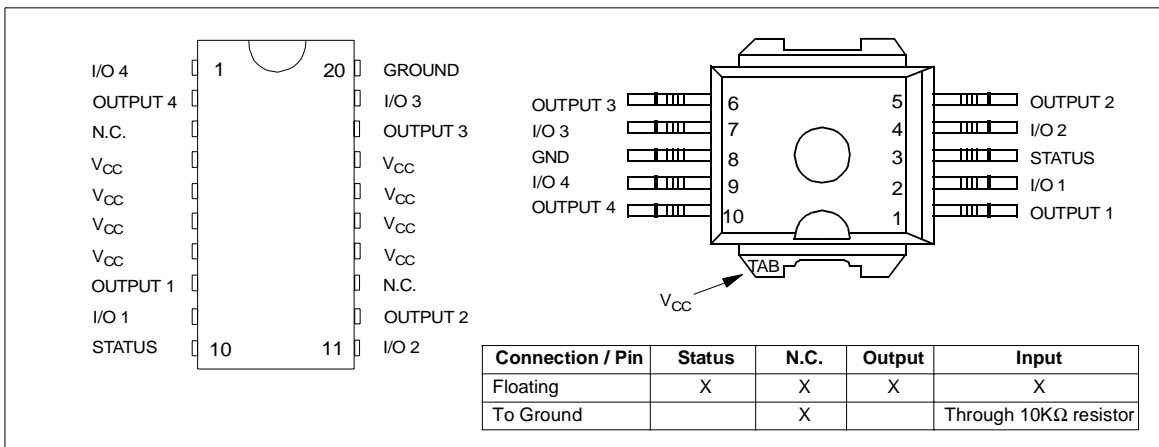

CURRENT AND VOLTAGE CONVENTIONS

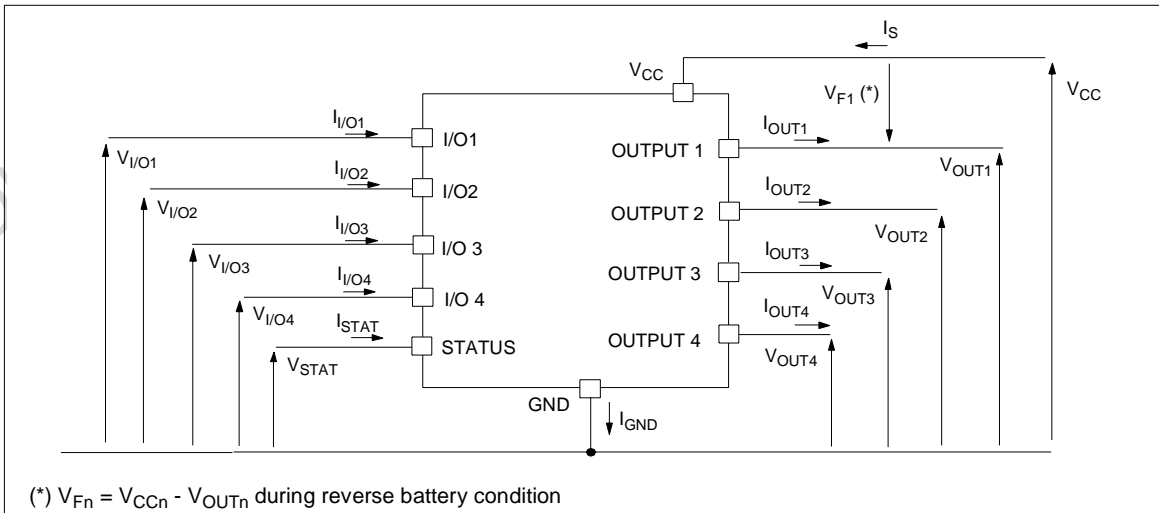

THERMAL DATA

Symbol	Parameter		Value		Unit
			SO-20	PowerSO-10	
$R_{thj-amb}$	Thermal resistance junction-pins	(MAX)	8	-	°C/W
$R_{thj-case}$	Thermal resistance junction-ambient	(MAX)	58	52 ⁽¹⁾	°C/W
				37 ⁽²⁾	°C/W
$R_{thj-pin}$	Thermal resistance junction-case	(MAX)	-	1.4	°C/W

(1) When mounted on FR4 printed circuit board with 0.5cm² of copper area (at least 35μ thick) connected to all V_{CC} pins.

(2) When mounted on FR4 printed circuit board with 6cm² of copper area (at least 35μ thick) connected to all V_{CC} pins.

ELECTRICAL CHARACTERISTICS (8V < V_{CC} < 36V; -40°C < T_j < 150°C; unless otherwise specified)

POWER

Symbol	Parameter	Test Conditions	Min	Typ	Max	Unit
V _{CC}	Operating supply voltage		5.5		36	V
V _{USD}	Undervoltage shut-down		3	4	5.5	V
V _{OV}	Overvoltage shut-down		36	42	48	V
R _{ON}	On state resistance (per channel)	I _{OUT} =0.25A; T _j =25°C			270	mΩ
		I _{OUT} =0.25A			540	mΩ
I _S	Supply current	Off state; V _{CC} =24V; T _c =25°C		70	120	μA
		On state (all channels on)		5	10	mA
I _L GND	Output current	V _{CC} -V _{STAT} =V _{IN} =V _{GND} =24V V _{OUT} =0V			1	mA
I _{L(off)}	Off state output current	V _{IN} =V _{OUT} =0V	0		10	μA
I _{OUTleak}	Off state output leakage current	V _{IN} =V _{GND} =0V; V _{CC} =V _{OUT} =24V; T _{amb} =25°C			240	μA
I _{OUTleak}	Off state output leakage current	V _{IN} =V _{GND} =0V; V _{CC} =24V; V _{OUT} =10V; T _{amb} =25°C			100	μA

SWITCHING (V_{CC}=24V) (Per channel)

Symbol	Parameter	Test Conditions	Min	Typ	Max	Unit
t _{D(on)}	Turn-on delay time	R _L =96Ω from V _{IN} rising edge to V _{OUT} =2.4V		10		μs
t _{D(off)}	Turn-off delay time	R _L =96Ω from V _{IN} falling edge to V _{OUT} =21.6V		40		μs
(dV _{OUT} /dt) _{on}	Turn-on voltage slope	R _L =96Ω from V _{OUT} =2.4V to 19.2V		0.75		V/μs
(dV _{OUT} /dt) _{off}	Turn-off voltage slope	R _L =96Ω from V _{OUT} =21.6V to 2.4V		0.25		V/μs

PROTECTIONS (Per channel)

Symbol	Parameter	Test Conditions	Min	Typ	Max	Unit
I _{lim}	Current limitation		0.35	0.7	1.1	A
T _(hyst)	Thermal hysteresis		7	15		°C
T _{TSD}	Thermal shut-down temperature		150	175	200	°C
T _R	Reset temperature		135			°C
V _{demag}	Turn-off output clamp voltage	I _{OUT} =0.25A	V _{CC} -47	V _{CC} -52	V _{CC} -59	V

ELECTRICAL CHARACTERISTICS (continued)

LOGIC INPUT (Per channel)

Symbol	Parameter	Test Conditions	Min	Typ	Max	Unit
V_{IL}	Low level input voltage				1.25	V
I_{IL}	Low level input current	$V_{IN}=1.25V$	1			μA
V_{IH}	High level input voltage		3.25			V
I_{IH}	High level input current	$V_{IN}=3.25V$			10	μA
$V_{I(hyst)}$	Input hysteresis Voltage		0.5			V
I_{IN}	Input current	$V_{IN}=V_{CC}=36V$			200	μA
V_{OL}	I/O Output voltage	$I_{IN}=5mA$ (Fault condition)			1	V

STATUS PIN

Symbol	Parameter	Test conditions	Min	Typ	Max	Unit
V_{STAT}	Status low output voltage	$I_{STAT}=5mA$ (Fault condition)			1	V
I_{LSTAT}	Status leakage current	Normal operation; $V_{STAT}=V_{CC}=36V$			10	μA
C_{STAT}	Status pin input capacitance	Normal operation; $V_{STAT}=5V$			100	pF

V_{CC} - OUTPUT DIODE

Symbol	Parameter	Test Conditions	Min	Typ	Max	Unit
V_F	Forward on Voltage	$-I_{OUT}=0.3A$; $T_j=150^\circ C$			0.6	V

TRUTH TABLE

CONDITIONS	MCOUTn	I/On	OUTPUTn	STATUS
Normal operation	L	L	L	H
	H	H	H	H
Current limitation	L	L	L	H
	H	H	X	H
Overtemperature	L	L	L	L
	H	Driven low	L	L
Undervoltage	L	L	L	X
	H	H	L	X
Overvoltage	L	L	L	H
	H	H	L	H



SWITCHING CHARACTERISTICS

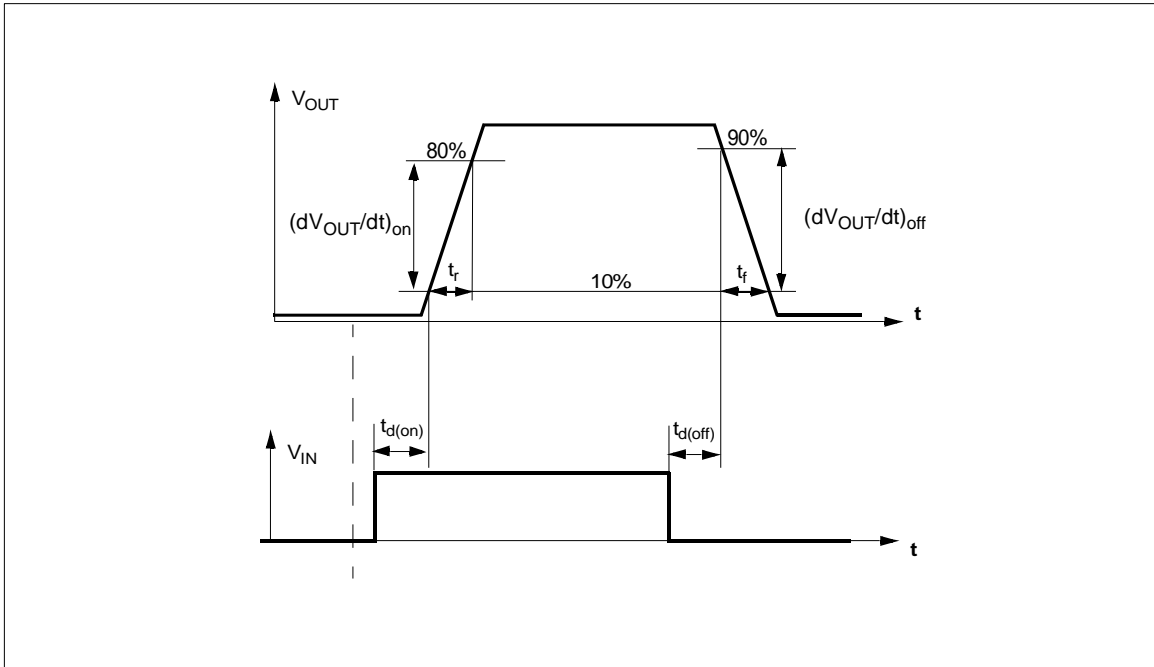

Typical application schematic

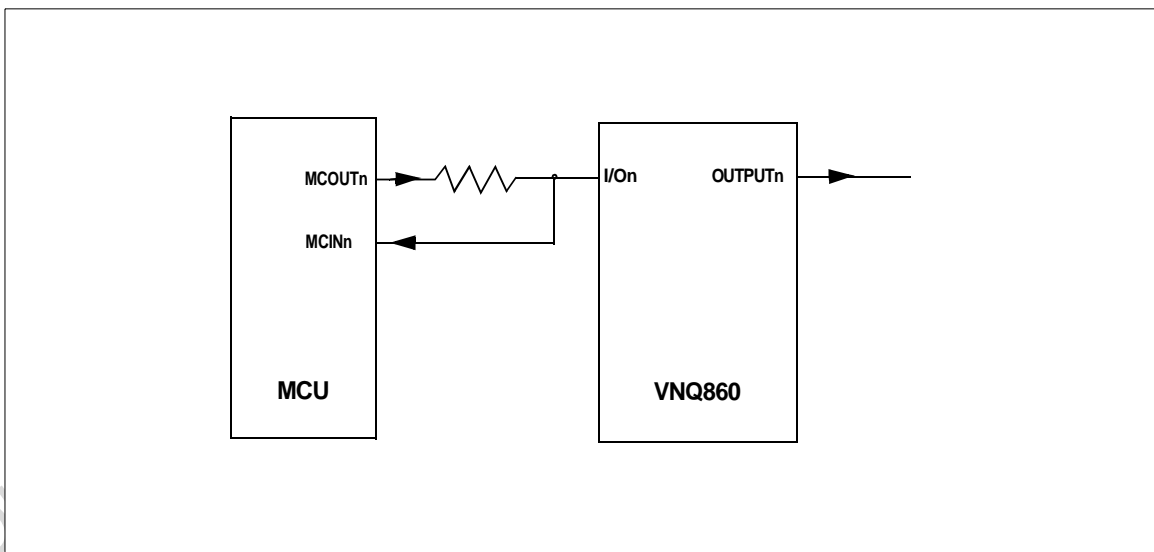
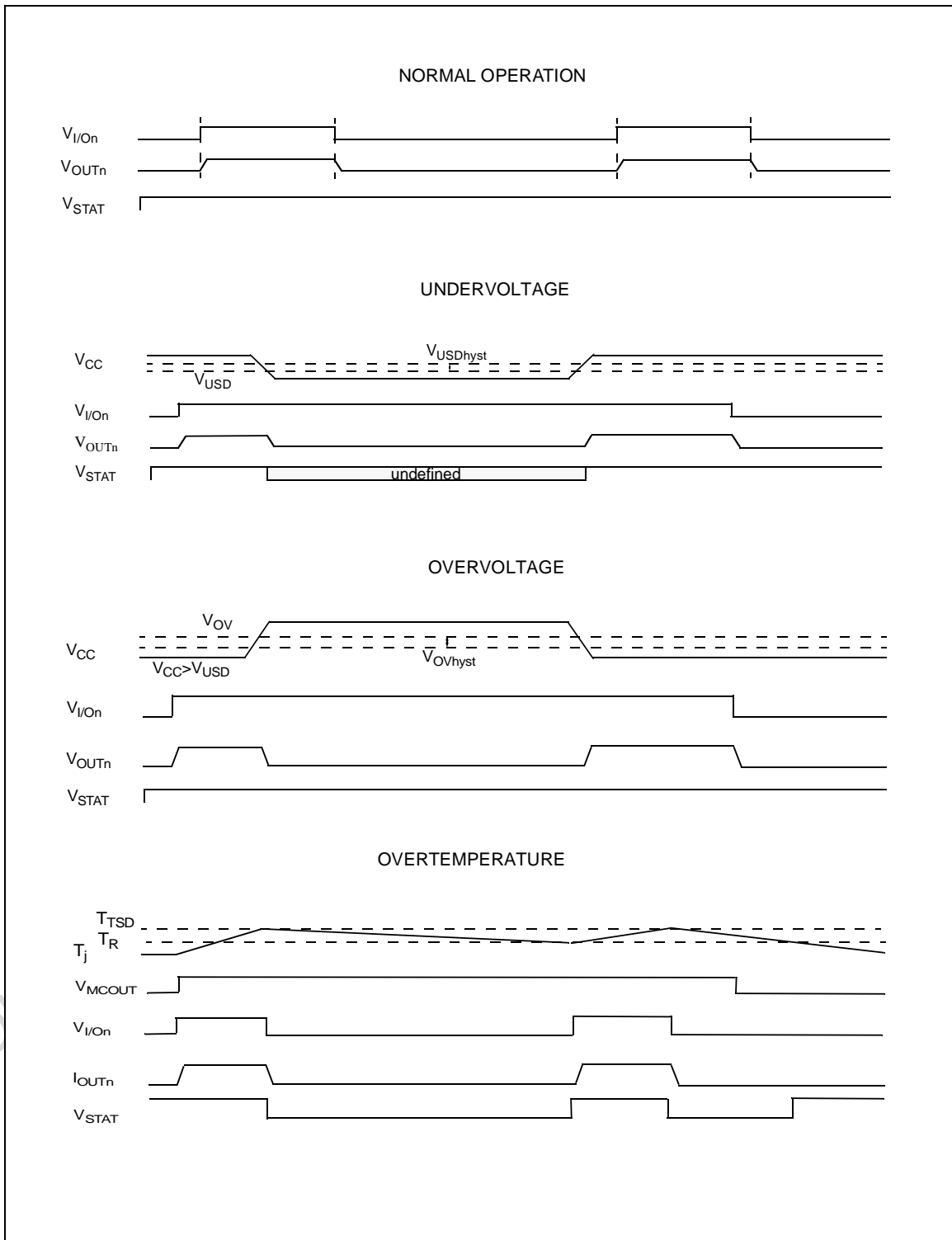
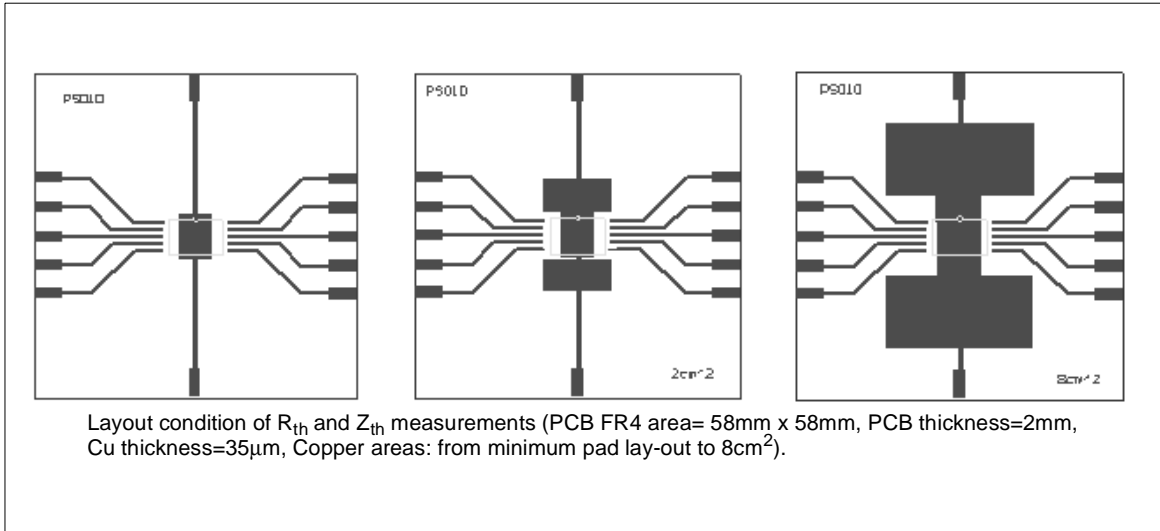

Figure 1: Waveforms



PowerSO-10™ THERMAL DATA

PowerSO-10™ PC Board



$R_{thj-amb}$ Vs PCB copper area in open box free air condition

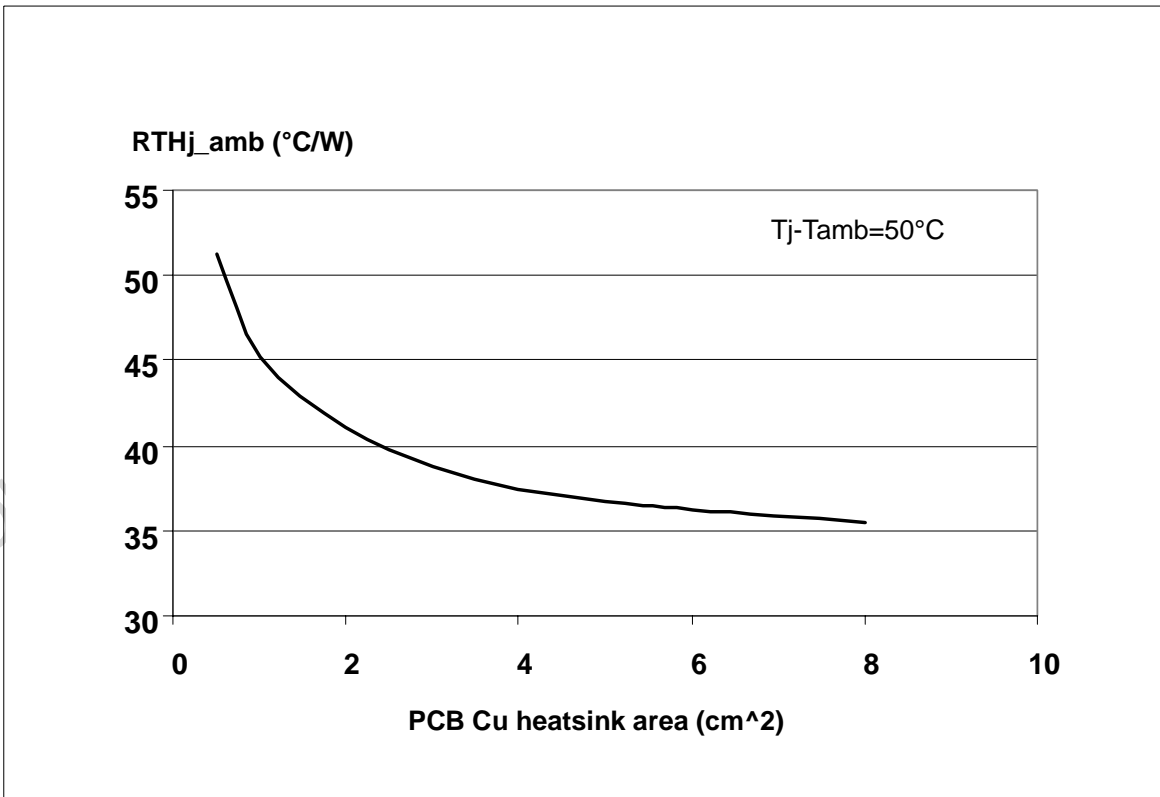

SO-20 MECHANICAL DATA

DIM.	mm.			inch		
	MIN.	TYP.	MAX.	MIN.	TYP.	MAX.
A			2.65			0.104
a1	0.10		0.20	0.004		0.007
a2			2.45			0.096
b	0.35		0.49	0.013		0.019
b1	0.23		0.32	0.009		0.012
C		0.50			0.020	
c1	45° (typ.)					
D	12.60		13.00	0.496		0.512
E	10.00		10.65	0.393		0.419
e		1.27			0.050	
F	7.40		7.60	0.291		0.299
L	0.50		1.27	0.19		0.050
M			0.75			0.029
S	8° (max.)					

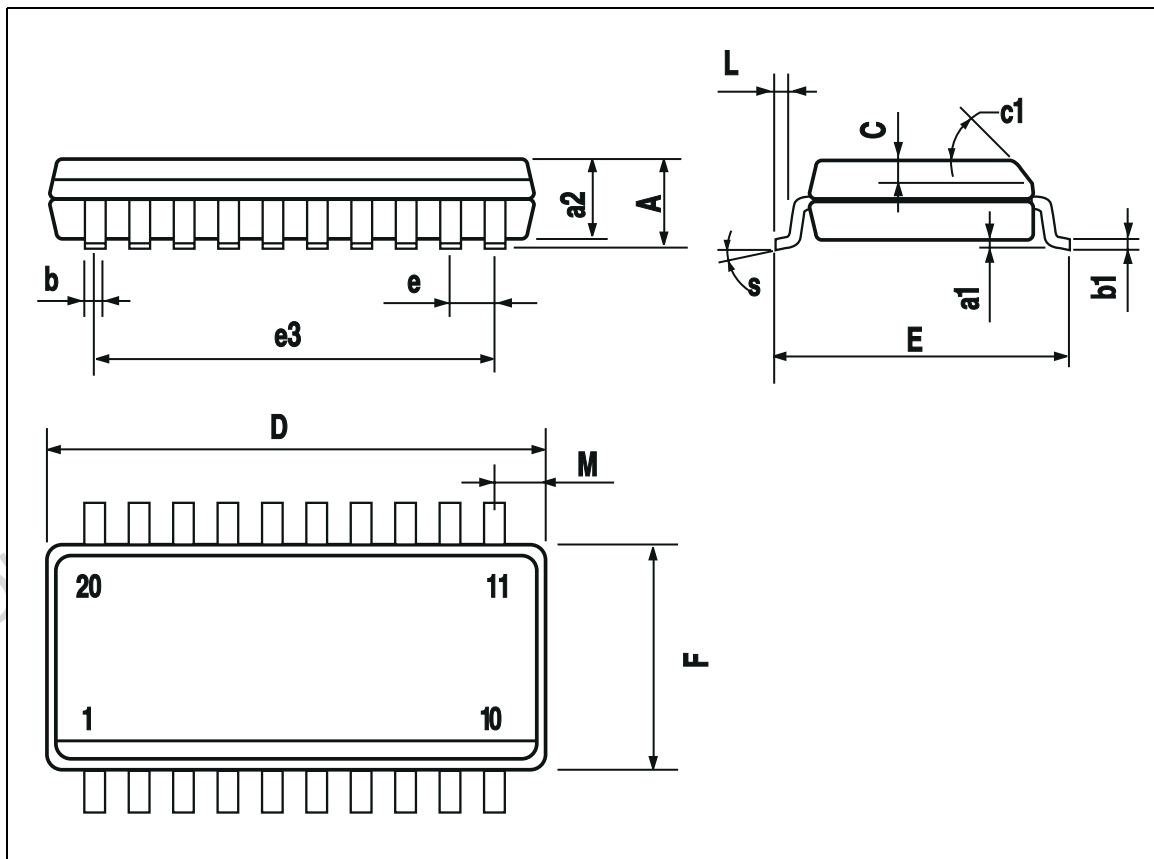

PowerSO-10™ MECHANICAL DATA

DIM.	mm.			inch		
	MIN.	TYP	MAX.	MIN.	TYP.	MAX.
A	3.35		3.65	0.132		0.144
A (*)	3.4		3.6	0.134		0.142
A1	0.00		0.10	0.000		0.004
B	0.40		0.60	0.016		0.024
B (*)	0.37		0.53	0.014		0.021
C	0.35		0.55	0.013		0.022
C (*)	0.23		0.32	0.009		0.0126
D	9.40		9.60	0.370		0.378
D1	7.40		7.60	0.291		0.300
E	9.30		9.50	0.366		0.374
E2	7.20		7.60	0.283		300
E2 (*)	7.30		7.50	0.287		0.295
E4	5.90		6.10	0.232		0.240
E4 (*)	5.90		6.30	0.232		0.248
e		1.27			0.050	
F	1.25		1.35	0.049		0.053
F (*)	1.20		1.40	0.047		0.055
H	13.80		14.40	0.543		0.567
H (*)	13.85		14.35	0.545		0.565
h		0.50			0.002	
L	1.20		1.80	0.047		0.070
L (*)	0.80		1.10	0.031		0.043
α	0°		8°	0°		8°
α (*)	2°		8°	2°		8°

(*) Muar only POA P013P

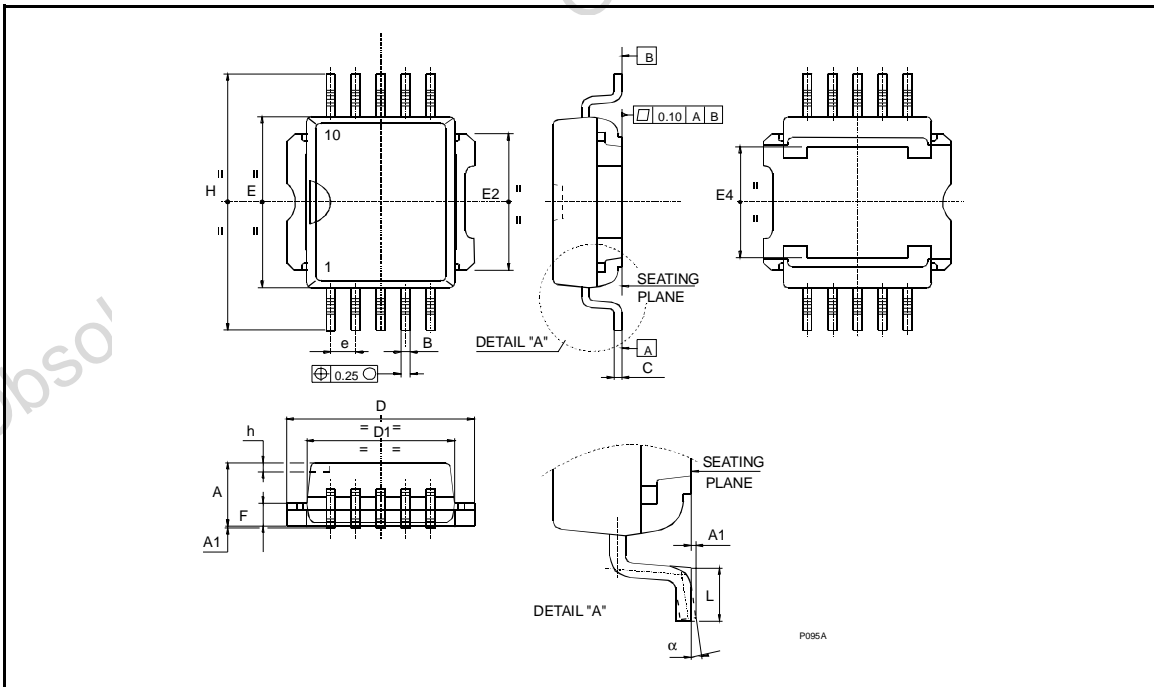

PowerSO-10™ SUGGESTED PAD LAYOUT

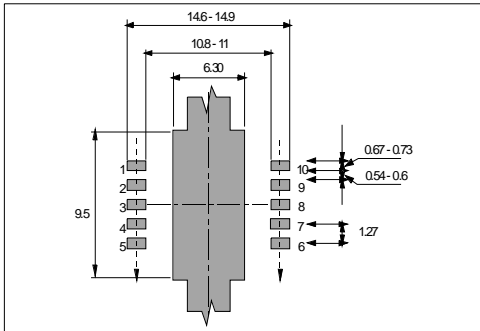

TUBE SHIPMENT (no suffix)

All dimensions are in mm.

	Base Q.ty	Bulk Q.ty	Tube length (± 0.5)	A	B	C (± 0.1)
Casablanca	50	1000	532	10.4	16.4	0.8
Muar	50	1000	532	4.9	17.2	0.8

TAPE AND REEL SHIPMENT (suffix "13TR")

40mm min. Access hole at slot location

Full radius

Tape slot in core for tape start 2.5mm min. width.

40mm min. Access hole at slot location

T

N

G measured at hub

REEL DIMENSIONS

Base Q.ty	600
Bulk Q.ty	600
A (max)	330
B (min)	1.5
C (± 0.2)	13
F	20.2
G (+ 2 / -0)	24.4
N (min)	60
T (max)	30.4

All dimensions are in mm.

TAPE DIMENSIONS

According to Electronic Industries Association (EIA) Standard 481 rev. A, Feb. 1986

Tape width	W	24
Tape Hole Spacing	P0 (± 0.1)	4
Component Spacing	P	24
Hole Diameter	D (± 0.1/-0)	1.5
Hole Diameter	D1 (min)	1.5
Hole Position	F (± 0.05)	11.5
Compartment Depth	K (max)	6.5
Hole Spacing	P1 (± 0.1)	2

All dimensions are in mm.

TOP COVER TAPE

User Direction of Feed

End

Start

No components

Components

No components

500mm min

Empty components pockets sealed with cover tape.

User direction of feed

SO-20 TUBE SHIPMENT (no suffix)

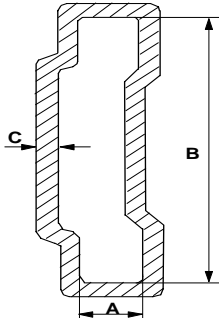

Base Q.ty	40
Bulk Q.ty	800
Tube length (± 0.5)	532
A	3.5
B	13.8
C (± 0.1)	0.6

All dimensions are in mm.

TAPE AND REEL SHIPMENT (suffix "13TR")

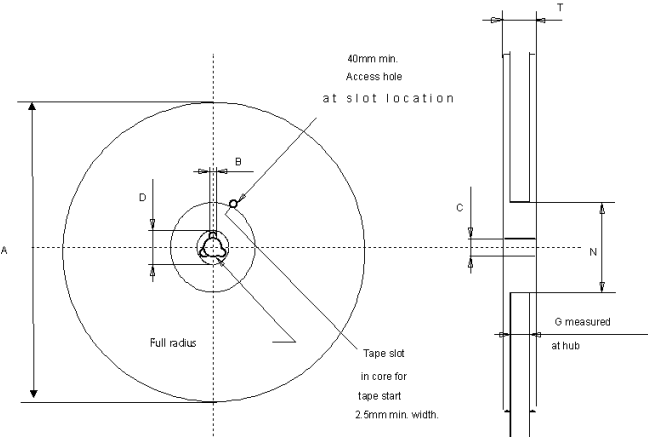

Base Q.ty	1000
Bulk Q.ty	1000
A (max)	330
B (min)	1.5
C (± 0.2)	13
F	20.2
G (+ 2 / -0)	24.4
N (min)	60
T (max)	30.4

TAPE DIMENSIONS

According to Electronic Industries Association (EIA) Standard 481 rev. A, Feb 1986

Tape width	W	24
Tape Hole Spacing	P0 (± 0.1)	4
Component Spacing	P	12
Hole Diameter	D ($\pm 0.1/-0$)	1.5
Hole Diameter	D1 (min)	1.5
Hole Position	F (± 0.05)	11.5
Compartment Depth	K (max)	6.5
Hole Spacing	P1 (± 0.1)	2

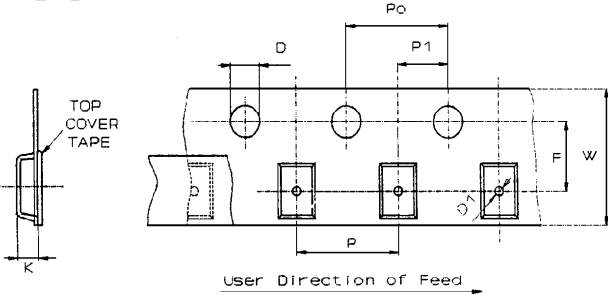

All dimensions are in mm.

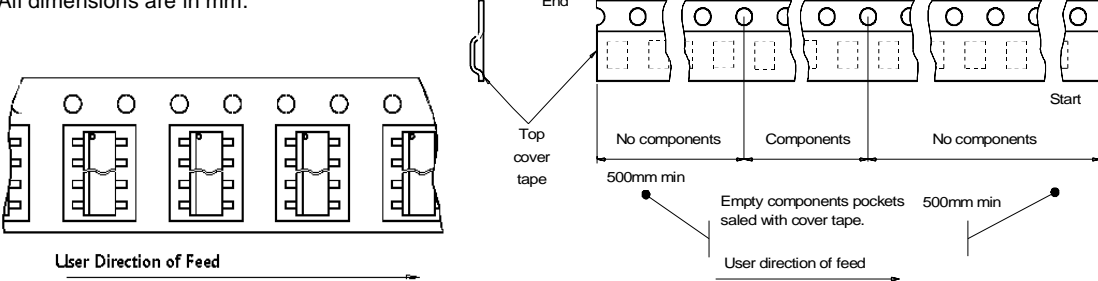

REVISION HISTORY

Date	Revision	Description of Changes
Jul 2004	1	<ul style="list-style-type: none">- Minor changes.- Order Codes table insertion (page 1).- Current and voltage convention update (page 2).- "Configuration diagram (top view) & suggested connections for unused and n.c. pins" insertion (page 2).- 6cm² Cu condition insertion in Thermal Data table (page 3).- V_{CC} - OUTPUT DIODE section insertion (page 4).- SO-20 Shipment Data insertion (page 11)- Revision History table insertion (page12).- Disclaimers update (page 13).



Information furnished is believed to be accurate and reliable. However, STMicroelectronics assumes no responsibility for the consequences of use of such information nor for any infringement of patents or other rights of third parties which may result from its use. No license is granted by implication or otherwise under any patent or patent rights of STMicroelectronics. Specifications mentioned in this publication are subject to change without notice. This publication supersedes and replaces all information previously supplied. STMicroelectronics products are not authorized for use as critical components in life support devices or systems without express written approval of STMicroelectronics.

The ST logo is a trademark of STMicroelectronics.
All other names are the property of their respective owners

© 2004 STMicroelectronics - Printed in ITALY- All Rights Reserved.

STMicroelectronics GROUP OF COMPANIES

Australia - Belgium - Brazil - Canada - China - Czech Republic - Finland - France - Germany - Hong Kong - India - Israel - Italy - Japan -
Malaysia - Malta - Morocco - Singapore - Spain - Sweden - Switzerland - United Kingdom - United States
<http://www.st.com>

