

Dual intelligent power low side switch

Features

- Multipower BCD technology
- Dual power low side driver with 2 x 5 A
- Low $R_{\text{DS(on)}}$ typically 200 m Ω @ $T_{\text{J}} = 25\text{ }^{\circ}\text{C}$
- Internal output clamping diodes $V_{\text{FB}} = 50\text{ V}$ for inductive recirculation
- Limited output voltage slew rate for low EMI
- μP compatible enable and input
- Wide operating supply voltage range 4.5 V to 45 V
- Real time diagnostic functions:
 - Output shorted to GND
 - Output shorted to V_{SS}
 - Open load
 - Load bypass
 - Over temperature
- Device protection functions:
 - Overload disable
 - Reverse battery up to -16 V @ V_{S}
 - Thermal shutdown

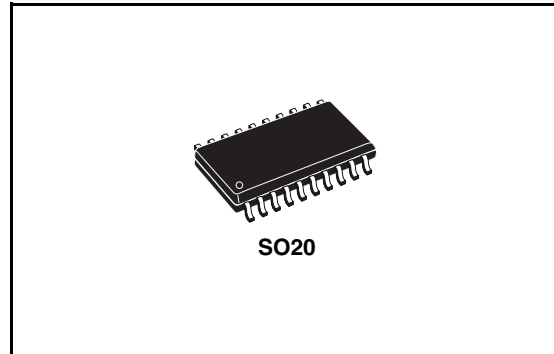

Description

The L9386 is a monolithic integrated dual low side driver realized in an advanced Multipower BCD mixed technology.

It is especially intended to drive valves in automotive environment. Its inputs are μP compatible for easy driving. Particular care has been taken to protect the device against failures, to avoid electro-magnetic interferences and to offer extensive real time diagnostic.

Table 1. Device summary

Part number	Order code	Package	Packing
L9386	L9386MD	SO20 (12+4+4)	Tube

Contents

1	Block and pins connection diagrams	3
2	Electrical specifications	4
	2.1 Absolute maximum ratings	4
	2.2 Thermal data	4
	2.3 Electrical characteristics	5
	2.4 Circuit description	10
3	Package information	12
4	Revision history	13

1 Block and pins connection diagrams

Figure 1. Block diagram

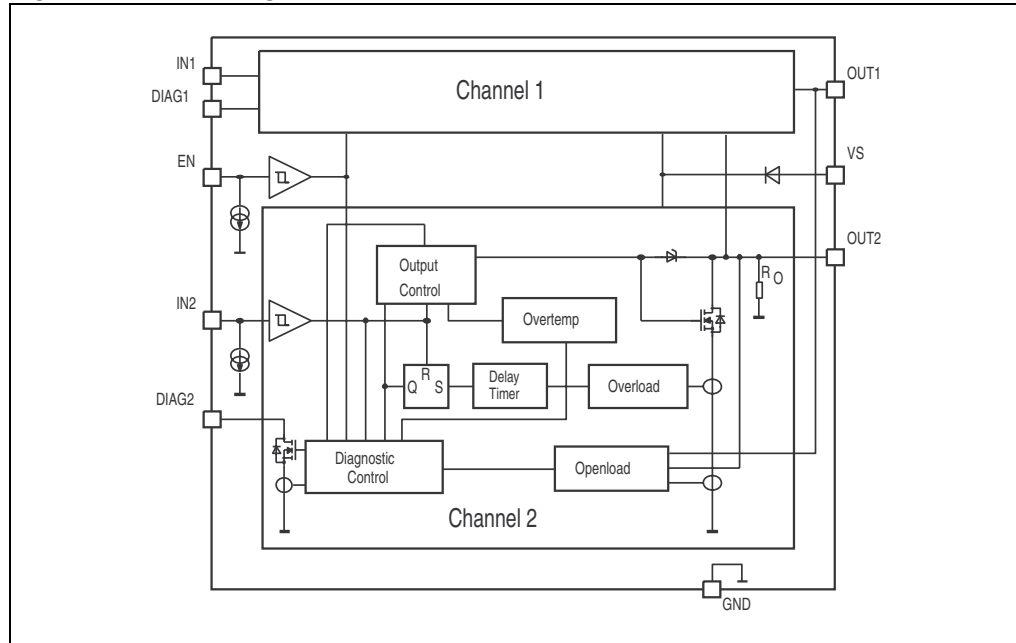
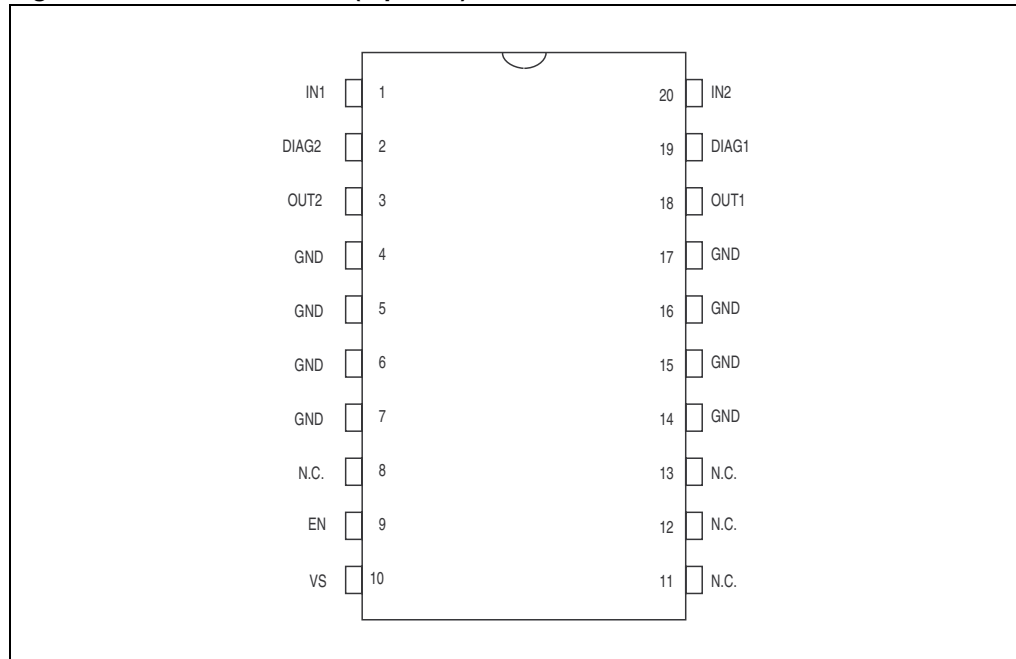

Figure 2. Pins connection (top view)



2 Electrical specifications

2.1 Absolute maximum ratings

Table 2. Absolute maximum ratings (no damage or latch)

Symbol	Parameter	Value	Unit
V _{SDC}	DC supply voltage	-16 to 45	V
V _{STR}	Transient supply voltage (t ≤ 500 ms)	60	V
V _{IN,EN}	Input voltage (I ≤ I 10 mA I)	-1.5 to 6	V
V _{DDC}	Diagnostic DC output voltage (I ≤ I 50 mA I)	-0.3 to 16	V
V _{ODC}	DC output voltage	45	V
V _{OTR}	Transient output voltage (R _L ≥ 4 Ω)	60	V
I _O	Output load current	internal limited	
I _{OR}	Reverse output current limited by load	-4	A
EO	Switch-off energy for inductive loads (t _{EO} = 250 μs, T = 5 ms)	50	mJ
T _{jEO}	Junction temperature during switch-off Σt = 30 min	175	°C
T _j	Junction temperature	-40 to +150	°C
T _{stg}	Storage temperature	-55 to +150	°C

2.2 Thermal data

Table 3. Thermal data

Symbol	Parameter	Value	Unit
T _{jDIS}	Thermal disable junction temperature threshold	160 to 190	°C
R _{th j-pins}	Thermal resistance junction to pins	14	°C/W

2.3 Electrical characteristics

Table 4. Electrical characteristics

(The electrical characteristics are valid within the below defined operative range, unless otherwise specified.)

Symbol	Parameter	Test condition	Min.	Typ.	Max.	Unit
V_S	Board supply voltage		4.5	12	32	V
V_D	Stabilized diagnostic output voltage		-0.3	5	16	V
T_j	Junction temperature		-40		150	°C
I_{SSB}	Static standby supply current	(1) (2) $V_{EN} = L, VO \leq VO_{UV}$		0.73	1.5 15	mA
I_S	DC supply current	(1) (2) $V_{EN} = V_{IN} = H$		1.3	5 15	mA
VD_L	Diagnostic output low voltage	(1) $I_D = 2 \text{ mA}$ (2) $I_D = 1 \text{ mA}$		0.35	0.5	V
ID_{LE}	Diagnostic output leakage current	$V_S = 0 \text{ V}$ or $V_S = \text{open}$; $V_D = 5.5 \text{ V}$ $T_j \leq 125 \text{ °C}$		0.1	2	mA
I_D	Diagnostic output current capability	$V_D \leq 16 \text{ V}$ $DIAG = L$	2	6	30	mA
VO_{UV}	Open load voltage threshold	$V_{EN} = X, V_{IN} = L$	0.51 xVS	0.55 xVS	0.59 xVS	V
$\Delta VO_{UV1,2}$	Open load difference voltage threshold	(1) $V_{EN} = X, V_{IN1,2} = L$ $V_S \geq VO_C \geq VO_{UV}$ $VO_C = \text{output voltage of other channel}$ (2)	$VO_C - 0.9V$	$VO_C - 1.25V$	$VO_C - 1.6V$	V
IO_{UC}	Open load current threshold	(3) $V_{EN} = V_{IN} = H$ (2)	100 20	320	480	mA
IO_{OC}	Over load current threshold	b)	5	7		A
VO_{CL}	Output voltage during clamping	$IO_{CL} \geq 100 \text{ mA}$	45	52	60	V
$S_{ON,OFF}$	Output (fall, rise) slew rate	(3) see Figure 4	200	1500	3200	V/ms
R_{IO}	Internal output pull down resistor	$V_{EN} = L$	10	20	40	K Ω
R_{DSON}	Output on resistance	$V_S > 9.5 \text{ V}$ $I_O = 2 \text{ A}$ $T_j = 25 \text{ °C}$ $T_j = 150 \text{ °C}$		200	300 500	m Ω
$V_{(EN,IN)L}$	Logic input low voltage	$ I_{EN}, I_{IN} \leq 10 \text{ mA}$ (1) (2)	-1.5 -1.5		1 0.5	V
$V_{(EN,IN)H}$	Logic input high voltage		2.2		5.5	V

Table 4. Electrical characteristics (continued)

(The electrical characteristics are valid within the below defined operative range, unless otherwise specified.)

Symbol	Parameter	Test condition	Min.	Typ.	Max.	Unit
$V_{(EN,IN)hys}$	Logic input hysteresis		0.2	0.4	1	V
I_{EN}	Enable input sink current	$1\text{ V} \leq V_{EN} \leq 5.5\text{ V}$	10	30	60	μA
I_{IN}	Logic input sink current	$1\text{ V} \leq V_{IN} \leq 5.5\text{ V}$	40	95	180	μA
t_{DON}	Output delay ON time	(3) see Figure 4		4	25	μs
t_{DOFF}	Output delay OFF time	(3) see Figure 4	5	15	30	μs
$t_{DH-L,Diag.}$	Diag. delay output OFF time	(3) see Figure 4	5	30	65	μs
t_{DIOu}	Diagnostic open load delay time	(3) see Figure 6		8	50	μs
t_{DOL}	Diagnostic overload delay switch-off time	(3) see Figure 3	50	160	300	μs

- $6.5\text{ V} \leq V_S \leq 16\text{ V}$ (Diagnostic operation range).
- $4.5\text{ V} \leq V_S < 6.5\text{ V}$ and $16\text{ V} < V_S \leq 32\text{ V}$ (Extended operation range).
- $9\text{ V} \leq V_S \leq 16\text{ V}$ (Nominal operating range)
 $R_L \leq 6\ \Omega$, $I_O \leq I_{OOC}$.

Table 5. Diagnostic table (operating range: $4.5\text{ V} \leq V_S \leq 32\text{ V}$)

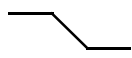
Conditions		EN	IN	Out	Diag.
Normal function		L	X	off	L
		H	L	off	L
		H	H	on ⁽¹⁾	H
GND short	$V_{Otyp} < 0.55\text{ V}$	L	X	off	H
Load bypass	$\Delta V_{O1,2} \geq 1.25\text{ V}$	H	L	off	H
Open load	$I_{Otyp} < 320\text{ mA}$	H	H	on ⁽¹⁾	L
$T_{jtyp} \geq 175\text{ }^\circ\text{C}$ overtemperature ⁽²⁾		X	L	off	H
		X	H	off	L
Latched overload $I_{Omin} > 5\text{ A}$		X	H	off	L
Reset overload latch		X		D.C.	D.C.

- for $4.5\text{ V} \leq V_S < 6.5\text{ V}$, $I_O \leq 2\text{ A}$ diag. table is valid.
- If one diag. status shows the overtemperature recognition, in parallel this output will be switched OFF internally. The corresponding channel should be switched OFF additional by its Input or ENABLE signal, otherwise the overload latch will be set after t_{DOL} is passed. This behavior will be related to the overdrop sensing which will be used as over load recognition.

Figure 3. Diagnostic overload delay time

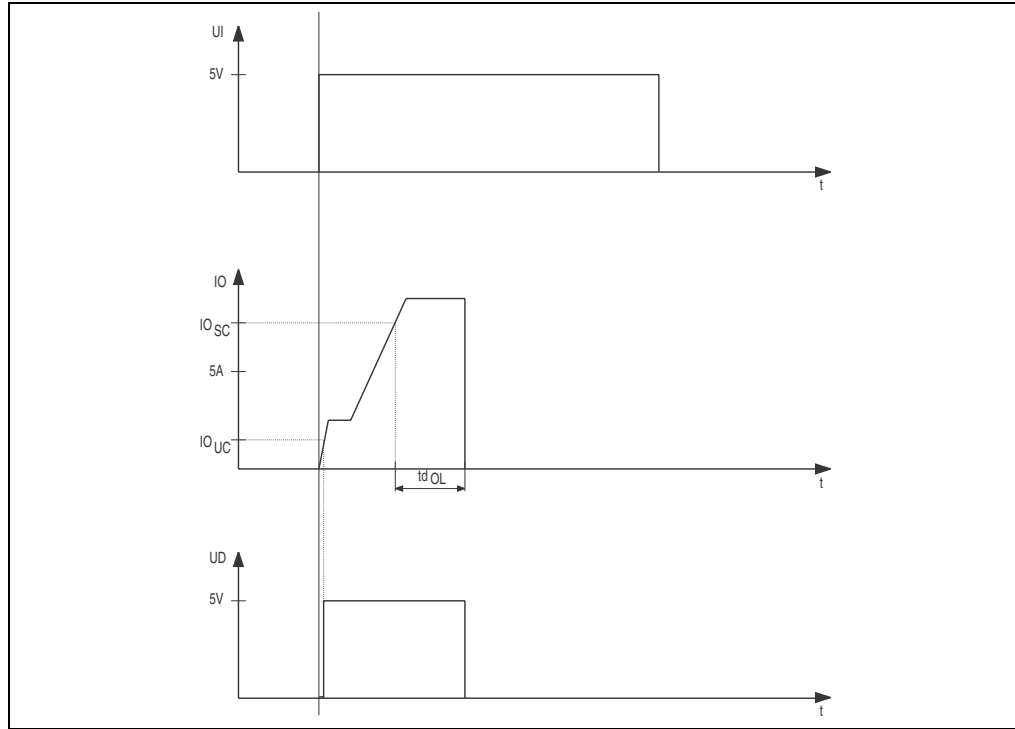

Figure 4. Output slope

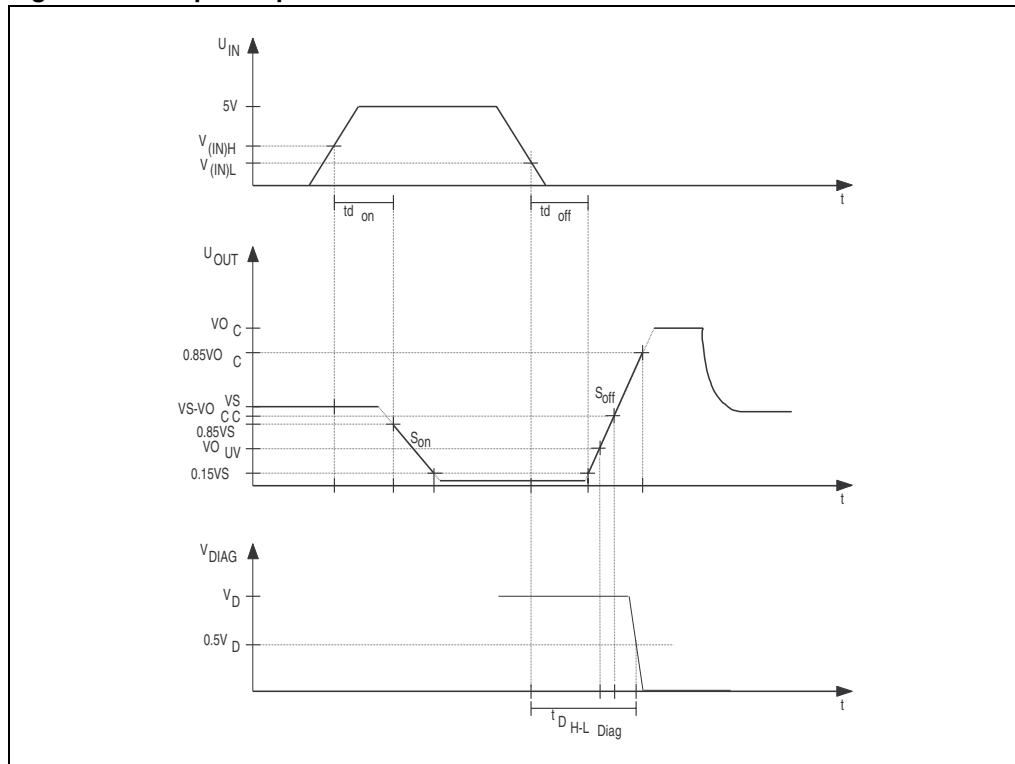

Figure 5. Open load voltage detection block diagram

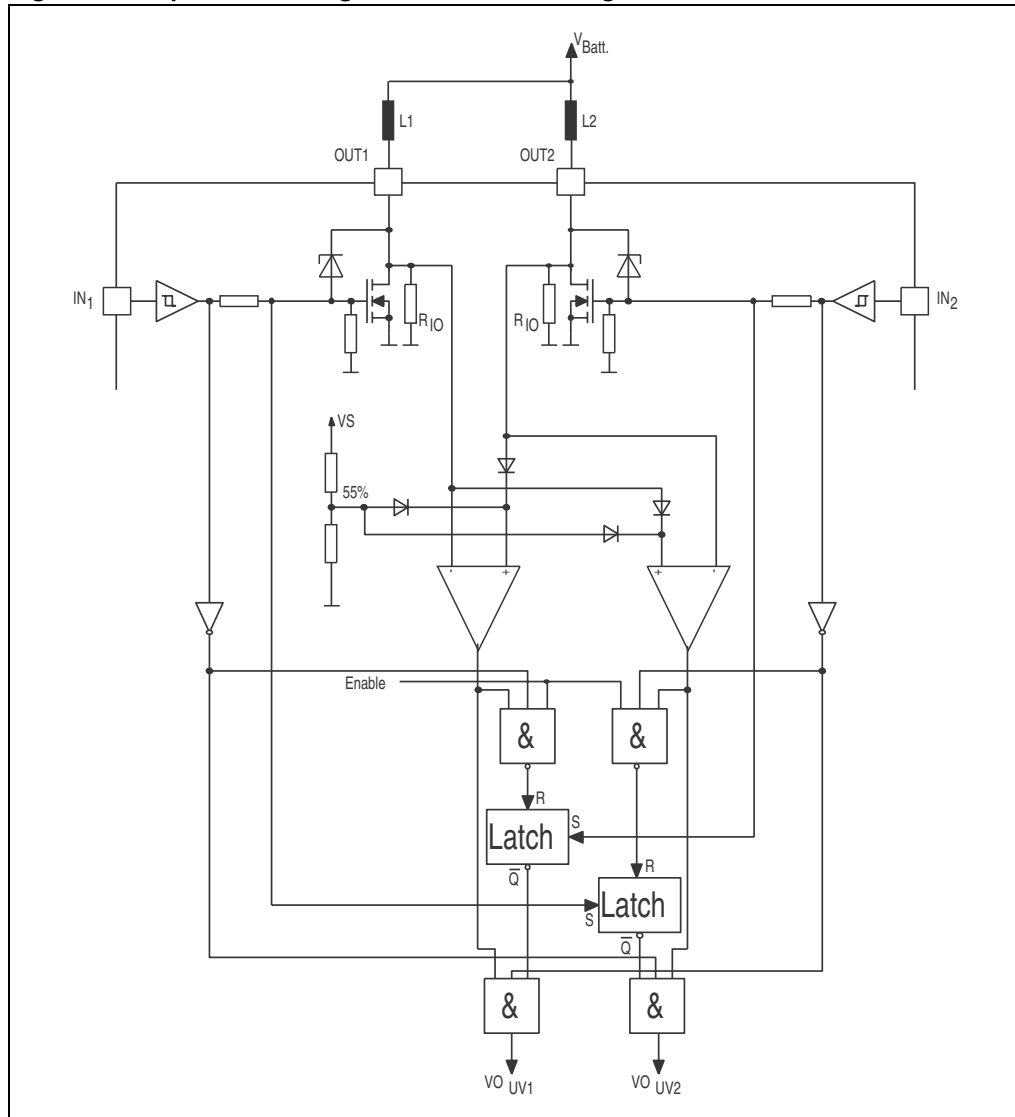
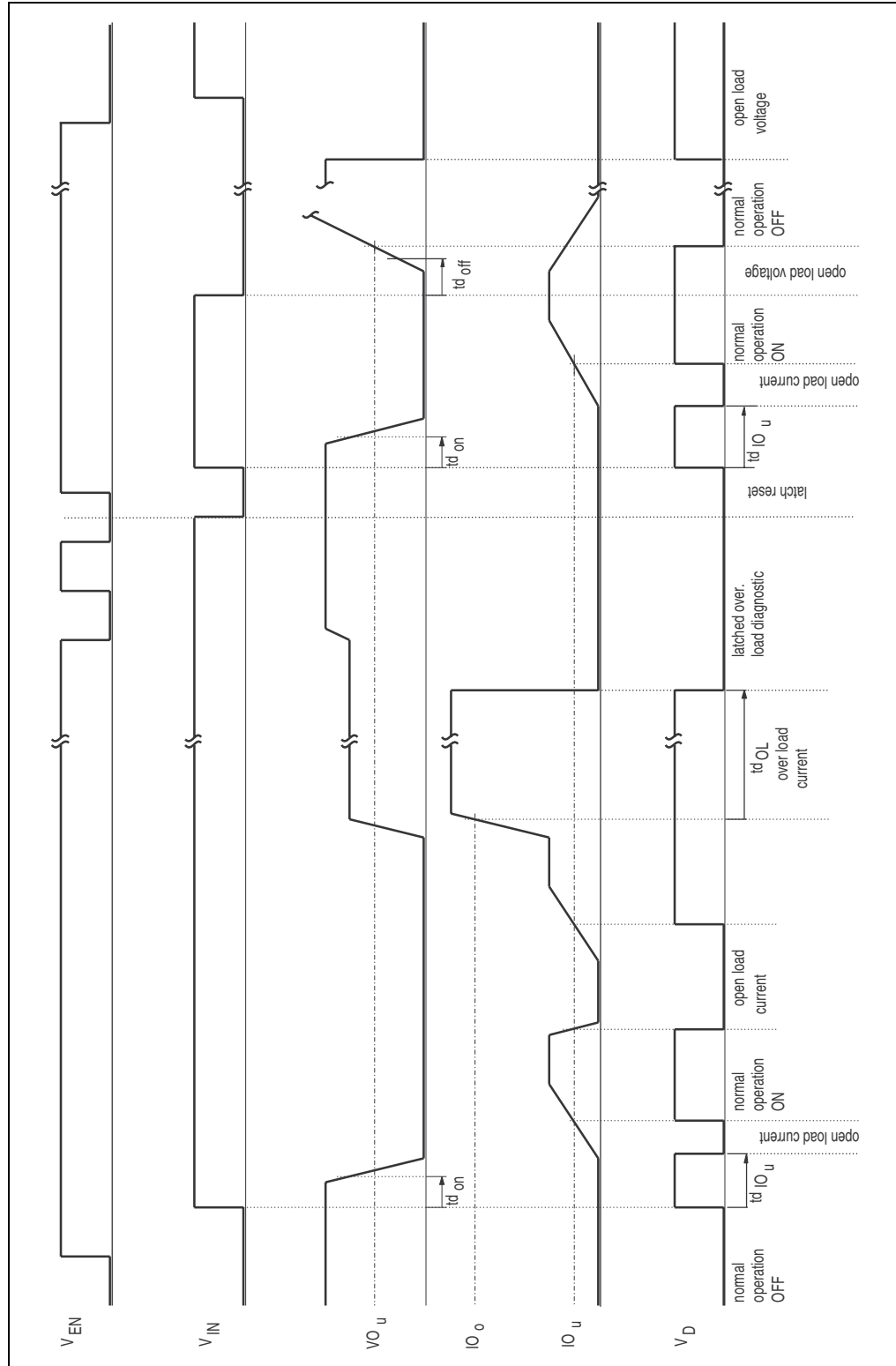

Figure 6. Logic diagram



2.4 Circuit description

The L9386 is a dual low side driver for inductive loads like valves in automotive environment.

The device is enabled by a common CMOS compatible ENABLE high signal. The internal pull down current sources at the ENABLE and INPUT pins protect the device in open input conditions against malfunctions. An output slope limitation for du/dt is implemented to reduce the EMI. An integrated active flyback voltage limitation clamps the output voltage during the flyback phase to 50V.

Each driver is protected against short circuit and thermal overload. In short circuit condition the output will be disabled after a short delay time t_{DOL} to suppress spikes. This disable is latched until a negative slope occur at the correspondent input pin. The thermal disable for $T_J > 175\text{ °C}$ of the output will be resetted if the junction temperature decreases about 20 °C below the disable threshold temperature.

For the real time error diagnosis the voltage and the current of the outputs are compared with internal fixed values V_{OUV} for OFF and I_{OUC} for ON conditions to recognize open load ($R_L \geq 20\text{ k}\Omega$, $R_L > 38\Omega$) in ON and OFF conditions. The diagnostic operates also in the extended supply voltage range of $4.5\text{ V} \leq V_S \leq 32\text{ V}$.

Also the output voltages $VO_{1,2}$ are compared against each other in OFF condition with a fixed offset of $\Delta VO_{UV\ 1,2}$ to recognize GND bypasses. To suppress mail ΔVO diagnoses during the flyback phases of the compared output, the ΔVO diagnostic

includes a latch function. Reaching the flyback clamping voltage VO_C the diagnostic signal is resetted by a latch. To activate again this kind of diagnostic a low signal at the correspondent INPUT or the ENABLE pin must occur (see also [Figure 5](#)).

The diagnostic output level in connection with different ENABLE and INPUT conditions allows to recognize different fail states, like overtemperature, short to VSS, short to GND, bypass to GND and disconnected load (see also [Table 5 on page 6](#)).

The diagnostic output is also protected against short to UD_{max} . Overstepping the over load current threshold IO_o , the output current will be limited internally during the diagnostic overload delay switch-off time t_{DOL} .

Figure 7. Open load voltage detection block diagram

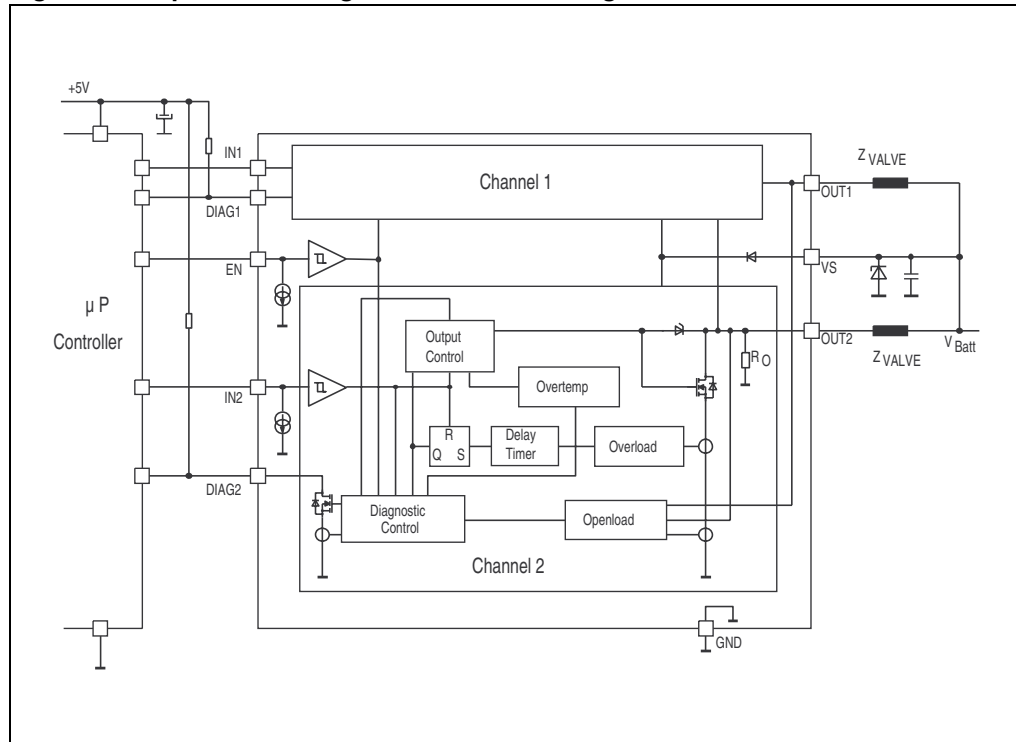

3 Package information

In order to meet environmental requirements, ST (also) offers these devices in ECOPACK® packages. ECOPACK® packages are lead-free. The category of second Level Interconnect is marked on the package and on the inner box label, in compliance with JEDEC Standard JESD97. The maximum ratings related to soldering conditions are also marked on the inner box label.

ECOPACK is an ST trademark. ECOPACK specifications are available at: www.st.com.

Figure 8. SO20 mechanical data and package dimensions

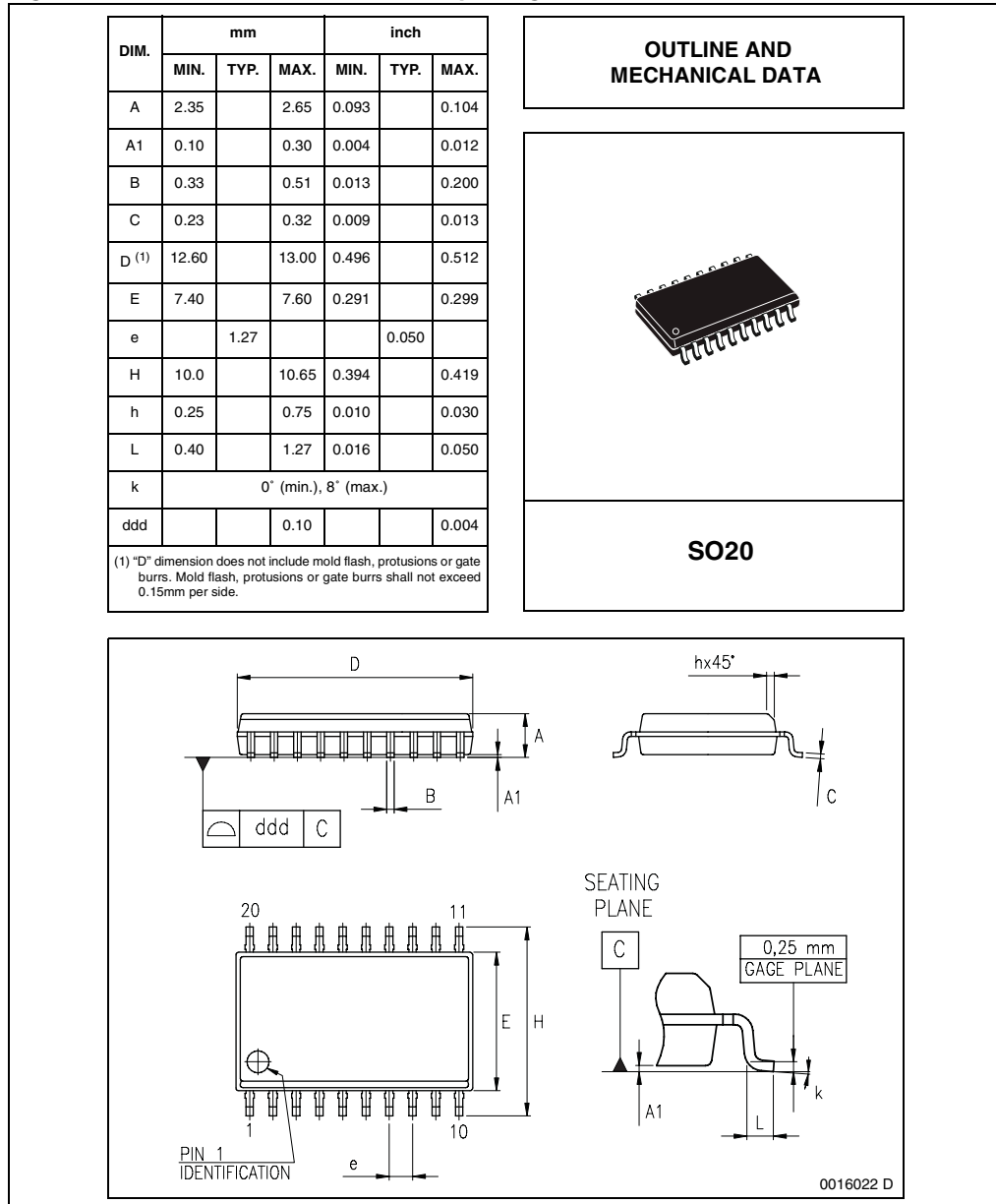

4 Revision history

Table 6. Document revision history

Date	Revision	Changes
16-Jan-2002	1	Initial release.
20-Sep-2003	2	Changed company name and logo.
16-Jul-2008	3	Document reformatted. Added Table 1: Device summary on page 1 .

Please Read Carefully:

Information in this document is provided solely in connection with ST products. STMicroelectronics NV and its subsidiaries ("ST") reserve the right to make changes, corrections, modifications or improvements, to this document, and the products and services described herein at any time, without notice.

All ST products are sold pursuant to ST's terms and conditions of sale.

Purchasers are solely responsible for the choice, selection and use of the ST products and services described herein, and ST assumes no liability whatsoever relating to the choice, selection or use of the ST products and services described herein.

No license, express or implied, by estoppel or otherwise, to any intellectual property rights is granted under this document. If any part of this document refers to any third party products or services it shall not be deemed a license grant by ST for the use of such third party products or services, or any intellectual property contained therein or considered as a warranty covering the use in any manner whatsoever of such third party products or services or any intellectual property contained therein.

UNLESS OTHERWISE SET FORTH IN ST'S TERMS AND CONDITIONS OF SALE ST DISCLAIMS ANY EXPRESS OR IMPLIED WARRANTY WITH RESPECT TO THE USE AND/OR SALE OF ST PRODUCTS INCLUDING WITHOUT LIMITATION IMPLIED WARRANTIES OF MERCHANTABILITY, FITNESS FOR A PARTICULAR PURPOSE (AND THEIR EQUIVALENTS UNDER THE LAWS OF ANY JURISDICTION), OR INFRINGEMENT OF ANY PATENT, COPYRIGHT OR OTHER INTELLECTUAL PROPERTY RIGHT.

UNLESS EXPRESSLY APPROVED IN WRITING BY AN AUTHORIZED ST REPRESENTATIVE, ST PRODUCTS ARE NOT RECOMMENDED, AUTHORIZED OR WARRANTED FOR USE IN MILITARY, AIR CRAFT, SPACE, LIFE SAVING, OR LIFE SUSTAINING APPLICATIONS, NOR IN PRODUCTS OR SYSTEMS WHERE FAILURE OR MALFUNCTION MAY RESULT IN PERSONAL INJURY, DEATH, OR SEVERE PROPERTY OR ENVIRONMENTAL DAMAGE. ST PRODUCTS WHICH ARE NOT SPECIFIED AS "AUTOMOTIVE GRADE" MAY ONLY BE USED IN AUTOMOTIVE APPLICATIONS AT USER'S OWN RISK.

Resale of ST products with provisions different from the statements and/or technical features set forth in this document shall immediately void any warranty granted by ST for the ST product or service described herein and shall not create or extend in any manner whatsoever, any liability of ST.

ST and the ST logo are trademarks or registered trademarks of ST in various countries.

Information in this document supersedes and replaces all information previously supplied.

The ST logo is a registered trademark of STMicroelectronics. All other names are the property of their respective owners.

© 2008 STMicroelectronics - All rights reserved

STMicroelectronics group of companies

Australia - Belgium - Brazil - Canada - China - Czech Republic - Finland - France - Germany - Hong Kong - India - Israel - Italy - Japan - Malaysia - Malta - Morocco - Singapore - Spain - Sweden - Switzerland - United Kingdom - United States of America

www.st.com