



# VND830ASP

## DOUBLE CHANNEL HIGH SIDE SOLID STATE RELAY

TYPE	$R_{DS(on)}$	$I_{OUT}$	$V_{CC}$
VND830ASP	60 m $\Omega$ (*)	6 A (*)	36 V (*)

(\*) Per channel

- DC SHORT CIRCUIT CURRENT: 6A
- CMOS COMPATIBLE INPUTS
- PROPORTIONAL LOAD CURRENT SENSE
- UNDERVOLTAGE AND OVERVOLTAGE SHUT-DOWN
- OVERVOLTAGE CLAMP
- THERMAL SHUT-DOWN
- CURRENT LIMITATION
- VERY LOW STAND-BY POWER DISSIPATION
- PROTECTION AGAINST:
  - LOSS OF GROUND AND LOSS OF  $V_{CC}$
- REVERSE BATTERY PROTECTION (\*\*)

### DESCRIPTION

The VND830ASP is a monolithic device made using STMicroelectronics VIPower M0-3 technology. It is intended for driving any kind of load with one

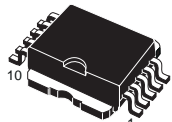

**PowerSO-10™**

ORDER CODES		
PACKAGE	TUBE	T&R
PowerSO-10™	VND830ASP	VND830ASP13TR

side connected to ground. Active  $V_{CC}$  pin voltage clamp protects the device against low energy spikes (see ISO7637 transient compatibility table). This device has two channels in high side configuration; each channel has an analog sense output on which the sensing current is proportional (according to a known ratio) to the corresponding load current. Built-in thermal shut-down and outputs current limitation protect the chip from over temperature and short circuit. Device turns off in case of ground pin disconnection.

### BLOCK DIAGRAM

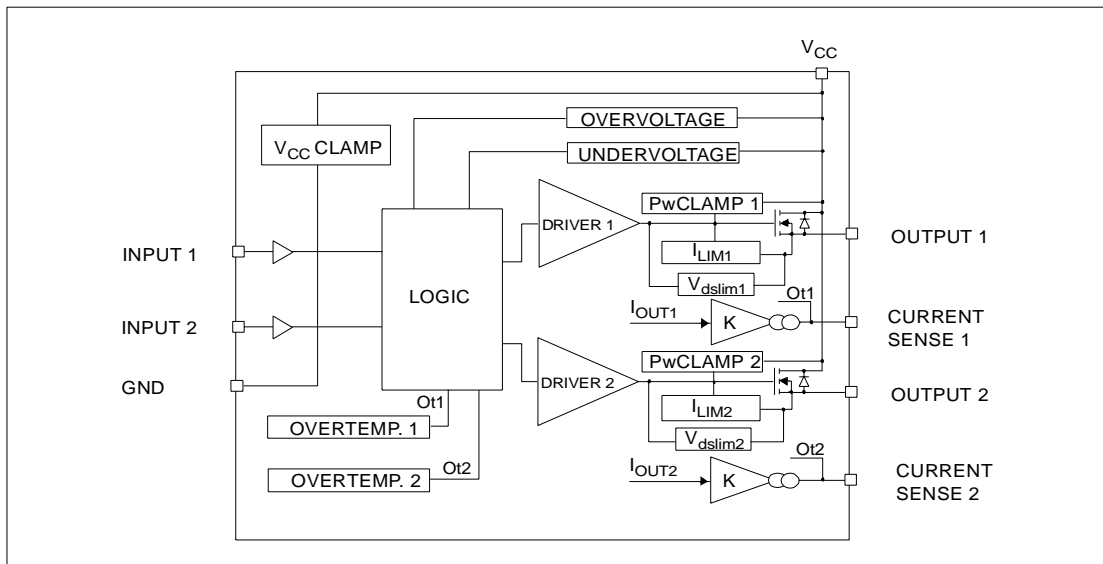

(\*\*) See application schematic at page 8

## VND830ASP

### ABSOLUTE MAXIMUM RATING

Symbol	Parameter	Value	Unit
$V_{CC}$	DC Supply Voltage	41	V
$-V_{CC}$	Reverse Supply Voltage	- 0.3	V
$-I_{GND}$	DC Reverse Ground Pin Current	- 200	mA
$I_{OUT}$	Output Current	Internally Limited	A
$I_R$	Reverse Output Current	- 6	A
$I_{IN}$	Input Current	+/- 10	mA
$V_{CSSENSE}$	Current Sense Maximum Voltage	-3	V
		+15	V
$V_{ESD}$	Electrostatic Discharge (Human Body Model: $R=1.5\Omega$ ; $C=100pF$ )		
	- INPUT	4000	V
	- CURRENT SENSE	2000	V
	- OUTPUT	5000	V
	- $V_{CC}$	5000	V
$E_{MAX}$	Maximum Switching Energy ( $L=1.8mH$ ; $R_L=0\Omega$ ; $V_{bat}=13.5V$ ; $T_{jstart}=150^\circ C$ ; $I_L=9A$ )	100	mJ
$P_{tot}$	Power Dissipation at $T_C=25^\circ C$	74	W
$T_j$	Junction Operating Temperature	Internally Limited	$^\circ C$
$T_C$	Case Operating Temperature	- 40 to 150	$^\circ C$
$T_{stg}$	Storage Temperature	- 55 to 150	$^\circ C$

### CONNECTION DIAGRAM (TOP VIEW)

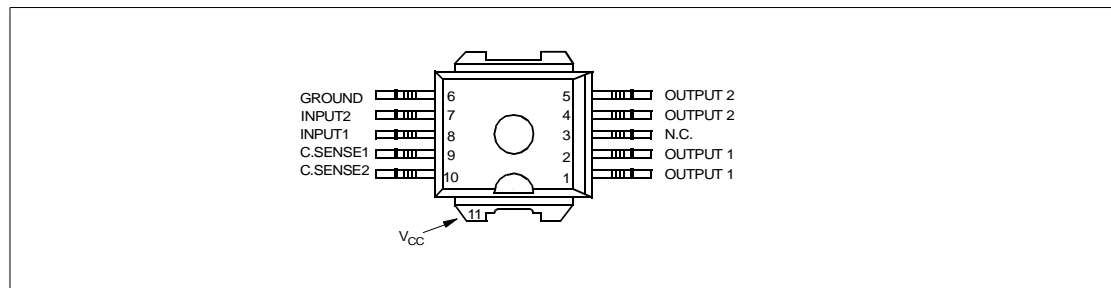

### CURRENT AND VOLTAGE CONVENTIONS

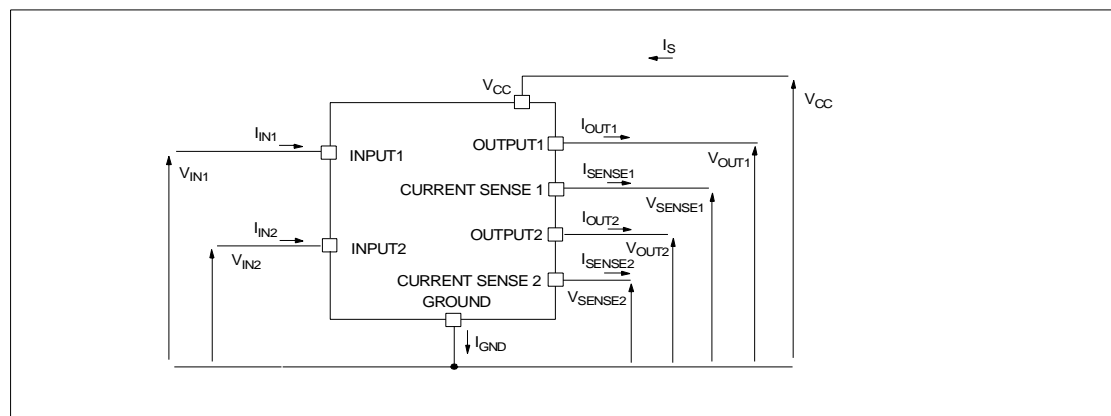

## THERMAL DATA

Symbol	Parameter	Value	Unit
$R_{thj-case}$	Thermal Resistance Junction-case	1.2	°C/W
$R_{thj-amb}$	Thermal Resistance Junction-ambient	51.2 (*)	°C/W

(\*) When mounted on a standard single-sided FR-4 board with 0.5cm<sup>2</sup> of Cu (at least 35µm thick). Horizontal mounting and no artificial air flow

ELECTRICAL CHARACTERISTICS (8V < V<sub>CC</sub> < 36V; -40°C < T<sub>j</sub> < 150°C, unless otherwise specified)

(Per each channel)

## POWER OUTPUT

Symbol	Parameter	Test Conditions	Min	Typ	Max	Unit
V <sub>CC</sub>	Operating Supply Voltage		5.5	13	36	V
V <sub>USD</sub>	Undervoltage Shut-down		3	4	5.5	V
V <sub>OV</sub>	Overvoltage Shut-down		36			V
R <sub>ON</sub>	On State Resistance	I <sub>OUT</sub> = 2A; T <sub>j</sub> = 25°C I <sub>OUT</sub> = 2A; T <sub>j</sub> = 150°C			60 120	mΩ mΩ
V <sub>clamp</sub>	Clamp voltage	I <sub>CC</sub> = 20 mA (see note 1)	41	48	55	V
I <sub>S</sub>	Supply Current	Off State; V <sub>CC</sub> = 13V; V <sub>IN</sub> = V <sub>OUT</sub> = 0V Off State; V <sub>CC</sub> = 13V; V <sub>IN</sub> = V <sub>OUT</sub> = 0V; T <sub>j</sub> = 25°C On State; V <sub>IN</sub> = 5V; V <sub>CC</sub> = 13V; I <sub>OUT</sub> = 0A; R <sub>SENSE</sub> = 3.9KΩ		12 12	40 25	µA µA
I <sub>L(off1)</sub>	Off State Output Current	V <sub>IN</sub> = V <sub>OUT</sub> = 0V; V <sub>CC</sub> = 36V; T <sub>j</sub> = 125°C	0		50	µA
I <sub>L(off2)</sub>	Off State Output Current	V <sub>IN</sub> = 0V; V <sub>OUT</sub> = 3.5V	-75		0	µA
I <sub>L(off3)</sub>	Off State Output Current	V <sub>IN</sub> = V <sub>OUT</sub> = 0V; V <sub>CC</sub> = 13V; T <sub>j</sub> = 125°C			5	µA
I <sub>L(off4)</sub>	Off State Output Current	V <sub>IN</sub> = V <sub>OUT</sub> = 0V; V <sub>CC</sub> = 13V; T <sub>j</sub> = 25°C			3	µA

SWITCHING (V<sub>CC</sub> = 13V)

Symbol	Parameter	Test Conditions	Min	Typ	Max	Unit
t <sub>d(on)</sub>	Turn-on Delay Time	R <sub>L</sub> = 6.5Ω from V <sub>IN</sub> rising edge to V <sub>OUT</sub> = 1.3V		30		µs
t <sub>d(off)</sub>	Turn-off Delay Time	R <sub>L</sub> = 6.5Ω from V <sub>IN</sub> falling edge to V <sub>OUT</sub> = 11.7V		30		µs
dV <sub>OUT</sub> /dt <sub>(on)</sub>	Turn-on Voltage Slope	R <sub>L</sub> = 6.5Ω from V <sub>OUT</sub> = 1.3V to V <sub>OUT</sub> = 10.4V		See relative diagram		V/µs
dV <sub>OUT</sub> /dt <sub>(off)</sub>	Turn-off Voltage Slope	R <sub>L</sub> = 6.5Ω from V <sub>OUT</sub> = 11.7V to V <sub>OUT</sub> = 1.3V		See relative diagram		V/µs

## LOGIC INPUT (Channels 1,2)

Symbol	Parameter	Test Conditions	Min	Typ	Max	Unit
V <sub>IL</sub>	Input low level voltage				1.25	V
I <sub>IL</sub>	Low level input current	V <sub>IN</sub> = 1.25V	1			µA
V <sub>IH</sub>	Input high level voltage		3.25			V
I <sub>IH</sub>	High level input current	V <sub>IN</sub> = 3.25V			10	µA
V <sub>I(hyst)</sub>	Input hysteresis voltage		0.5			V
V <sub>ICL</sub>	Input clamp voltage	I <sub>IN</sub> = 1mA I <sub>IN</sub> = -1mA	6	6.8 -0.7	8	V V

Note 1: V<sub>clamp</sub> and V<sub>OV</sub> are correlated. Typical difference is 5V.



## VND830ASP

### ELECTRICAL CHARACTERISTICS (continued)

#### V<sub>CC</sub> - OUTPUT DIODE

Symbol	Parameter	Test Conditions	Min	Typ	Max	Unit
V <sub>F</sub>	Forward on Voltage	-I <sub>OUT</sub> =2A; T <sub>J</sub> =150°C			0.6	V

#### PROTECTIONS

Symbol	Parameter	Test Conditions	Min	Typ	Max	Unit
I <sub>lim</sub>	Current limitation	V <sub>CC</sub> =13V	6	9	15	A
		5.5V<V <sub>CC</sub> <36V			15	A
T <sub>TSD</sub>	Thermal shut-down temperature		150	175	200	°C
T <sub>R</sub>	Thermal reset temperature		135			°C
T <sub>HYST</sub>	Thermal hysteresis		7	15		°C
V <sub>demag</sub>	Turn-off output voltage clamp	I <sub>OUT</sub> =2A; V <sub>IN</sub> =0V; L=6mH	V <sub>CC</sub> -41	V <sub>CC</sub> -48	V <sub>CC</sub> -55	V
V <sub>ON</sub>	Output voltage drop limitation	I <sub>OUT</sub> =10mA		50		mV

#### CURRENT SENSE (9V≤V<sub>CC</sub>≤16V) (See figure 1)

Symbol	Parameter	Test Conditions	Min	Typ	Max	Unit
K <sub>0</sub>	I <sub>OUT</sub> /I <sub>SENSE</sub>	I <sub>OUT1</sub> or I <sub>OUT2</sub> =0.05A; V <sub>SENSE</sub> =0.5V; other channels open; T <sub>J</sub> =-40°C...150°C	600	1300	2000	
K <sub>1</sub>	I <sub>OUT</sub> /I <sub>SENSE</sub>	I <sub>OUT1</sub> or I <sub>OUT2</sub> =0.25A; V <sub>SENSE</sub> =0.5V; other channels open; T <sub>J</sub> =-40°C...150°C	1000	1400	1900	
dK <sub>1</sub> /K <sub>1</sub>	Current Sense Ratio Drift	I <sub>OUT1</sub> or I <sub>OUT2</sub> =0.25A; V <sub>SENSE</sub> =0.5V; other channels open; T <sub>J</sub> =-40°C...150°C	-10		+10	%
K <sub>2</sub>	I <sub>OUT</sub> /I <sub>SENSE</sub>	I <sub>OUT1</sub> or I <sub>OUT2</sub> =1.6A; V <sub>SENSE</sub> =4V; other channels open; T <sub>J</sub> =-40°C	1280	1500	1800	
		T <sub>J</sub> =25°C...150°C	1300	1500	1780	
dK <sub>2</sub> /K <sub>2</sub>	Current Sense Ratio Drift	I <sub>OUT1</sub> or I <sub>OUT2</sub> =1.6A; V <sub>SENSE</sub> =4V; other channels open; T <sub>J</sub> =-40°C...150°C	-6		+6	%
K <sub>3</sub>	I <sub>OUT</sub> /I <sub>SENSE</sub>	I <sub>OUT1</sub> or I <sub>OUT2</sub> =2.5A; V <sub>SENSE</sub> =4V; other channels open; T <sub>J</sub> =-40°C	1280	1500	1680	
		T <sub>J</sub> =25°C...150°C	1340	1500	1600	
dK <sub>3</sub> /K <sub>3</sub>	Current Sense Ratio Drift	I <sub>OUT1</sub> or I <sub>OUT2</sub> =2.5A; V <sub>SENSE</sub> =4V; other channels open; T <sub>J</sub> =-40°C...150°C	-6		+6	%
I <sub>SENSE</sub>	Analog Sense Leakage Current	V <sub>IN</sub> =0V; I <sub>OUT</sub> =0A; V <sub>SENSE</sub> =0V; T <sub>J</sub> =-40°C...150°C	0		5	μA
		V <sub>IN</sub> =5V; I <sub>OUT</sub> =0A; V <sub>SENSE</sub> =0V; T <sub>J</sub> =-40°C...150°C	0		10	μA
V <sub>SENSE</sub>	Max Analog Sense Output Voltage	V <sub>CC</sub> =5.5V; I <sub>OUT1,2</sub> =1.3A; R <sub>SENSE</sub> =10kΩ	2			V
		V <sub>CC</sub> >8V; I <sub>OUT1,2</sub> =2.5A; R <sub>SENSE</sub> =10kΩ	4			V
V <sub>SENSEH</sub>	Sense Voltage in Overtemperature conditions	V <sub>CC</sub> =13V; R <sub>SENSE</sub> =3.9kΩ		5.5		V
R <sub>VSENSEH</sub>	Analog Sense Output Impedance in Overtemperature Condition	V <sub>CC</sub> =13V; T <sub>J</sub> >T <sub>TSD</sub> ; All Channels Open		400		Ω
t <sub>DSENSE</sub>	Current sense delay response	to 90% I <sub>SENSE</sub> (see note 2)			500	μs

Note 2: current sense signal delay after positive input slope.

Note: Sense pin doesn't have to be left floating.

## TRUTH TABLE (per channel)

CONDITIONS	INPUT	OUTPUT	SENSE
Normal operation	L	L	0
	H	H	Nominal
Overtemperature	L	L	0
	H	L	$V_{SENSEH}$
Undervoltage	L	L	0
	H	L	0
Overvoltage	L	L	0
	H	L	0
Short circuit to GND	L	L	0
	H	L	$(T_j < T_{TSD})$ 0
	H	L	$(T_j > T_{TSD})$ $V_{SENSEH}$
Short circuit to $V_{CC}$	L	H	0
	H	H	< Nominal
Negative output voltage clamp	L	L	0

## ELECTRICAL TRANSIENT REQUIREMENTS

ISO T/R 7637/1 Test Pulse	TEST LEVELS				Delays and Impedance
	I	II	III	IV	
1	-25 V	-50 V	-75 V	-100 V	2 ms 10 $\Omega$
2	+25 V	+50 V	+75 V	+100 V	0.2 ms 10 $\Omega$
3a	-25 V	-50 V	-100 V	-150 V	0.1 $\mu$ s 50 $\Omega$
3b	+25 V	+50 V	+75 V	+100 V	0.1 $\mu$ s 50 $\Omega$
4	-4 V	-5 V	-6 V	-7 V	100 ms, 0.01 $\Omega$
5	+26.5 V	+46.5 V	+66.5 V	+86.5 V	400 ms, 2 $\Omega$

ISO T/R 7637/1 Test Pulse	TEST LEVELS RESULTS			
	I	II	III	IV
1	C	C	C	C
2	C	C	C	C
3a	C	C	C	C
3b	C	C	C	C
4	C	C	C	C
5	C	E	E	E

CLASS	CONTENTS
C	All functions of the device are performed as designed after exposure to disturbance.
E	One or more functions of the device is not performed as designed after exposure to disturbance and cannot be returned to proper operation without replacing the device.

## VND830ASP

**Figure 1:**  $I_{OUT}/I_{SENSE}$  versus  $I_{OUT}$

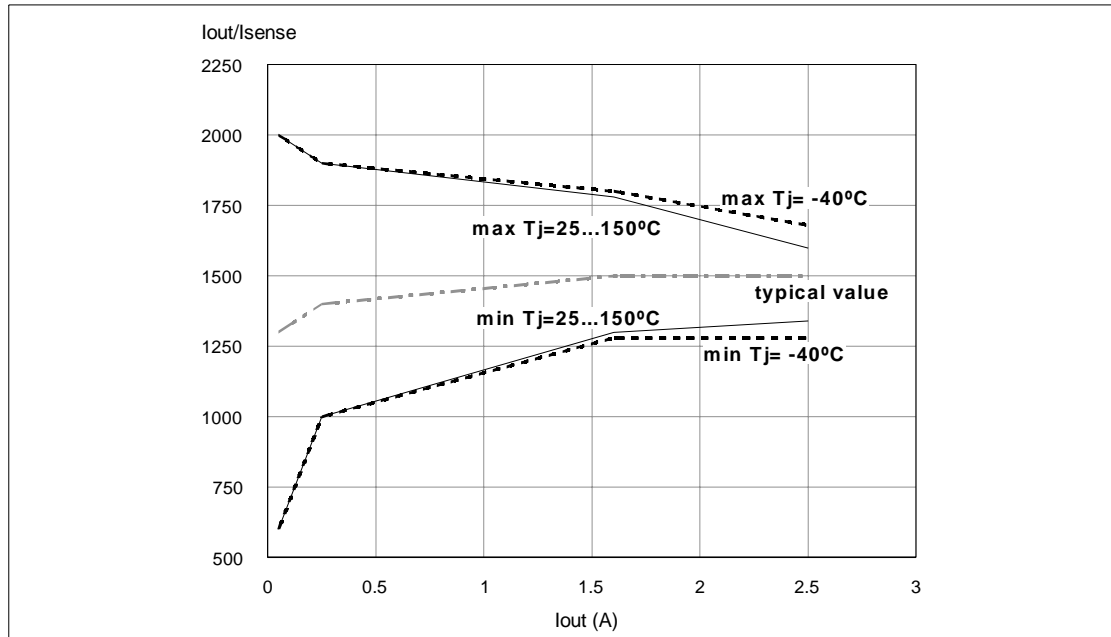

**Figure 2:** Switching Characteristics (Resistive load  $R_L = 6.5\Omega$ )

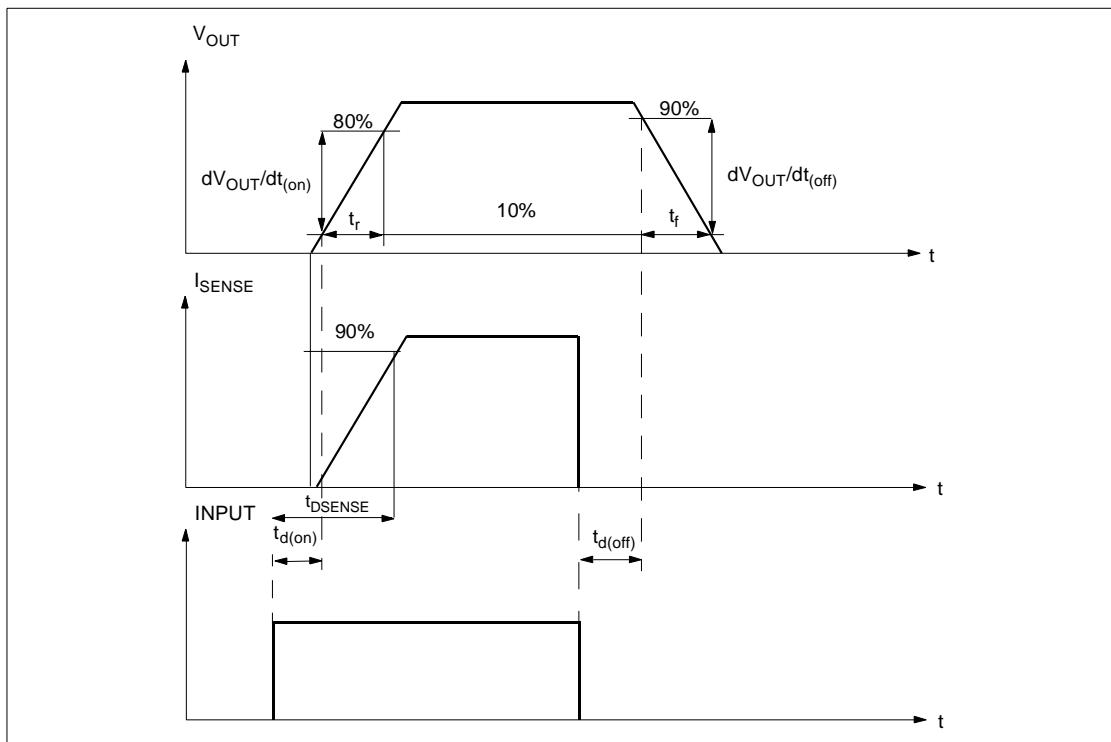
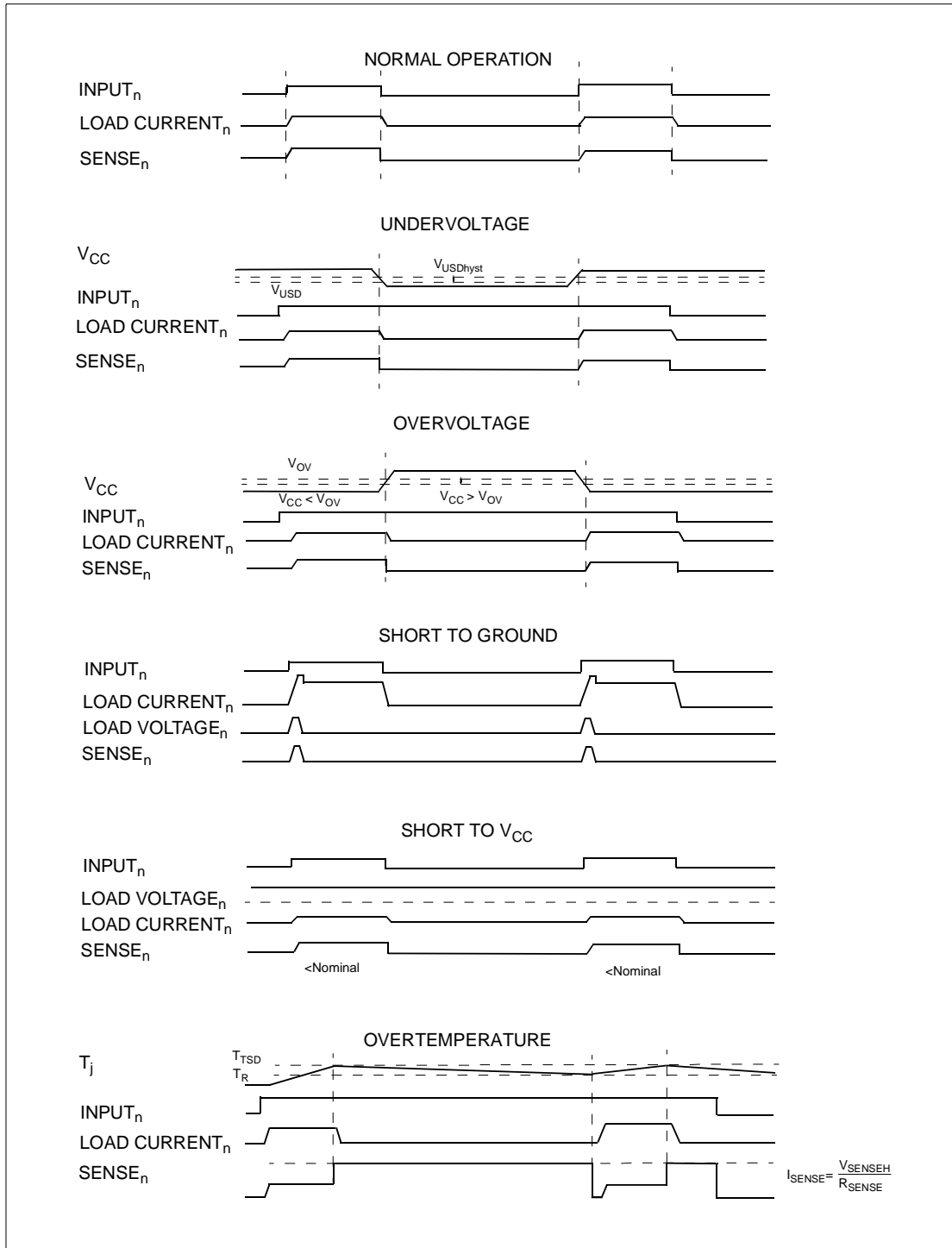
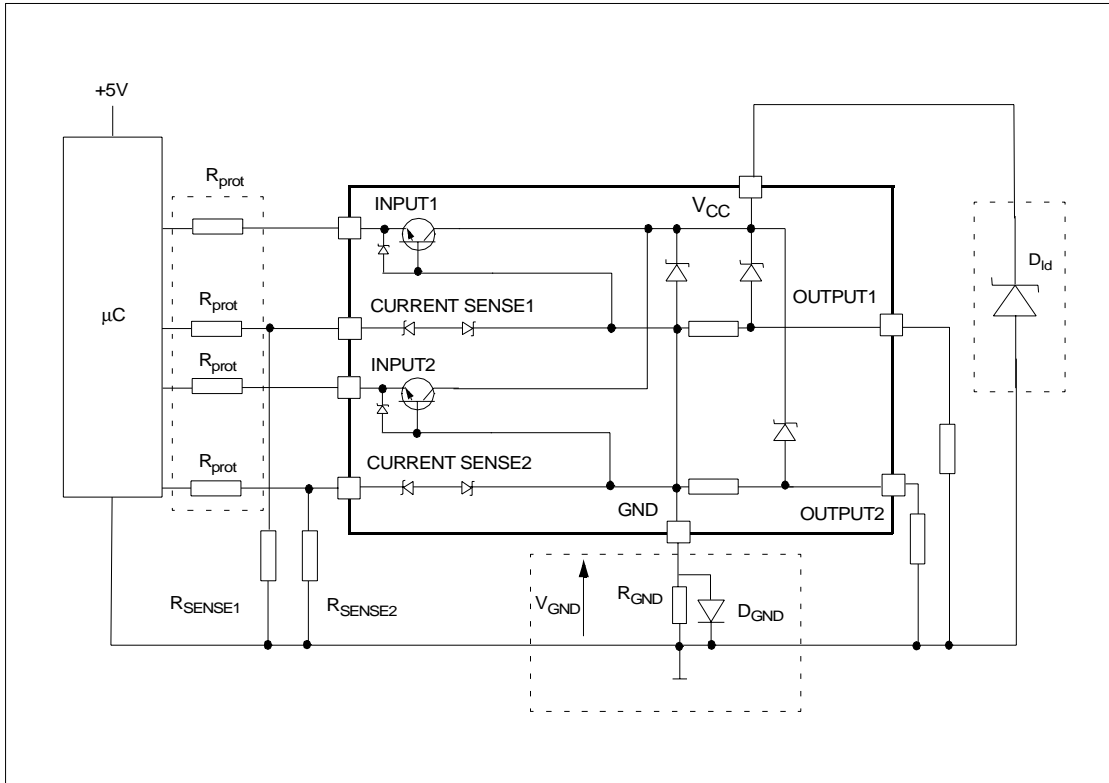

Figure 3: Waveforms



APPLICATION SCHEMATIC



**GND PROTECTION NETWORK AGAINST REVERSE BATTERY**

**Solution 1:** Resistor in the ground line ( $R_{GND}$  only). This can be used with any type of load.

The following is an indication on how to dimension the  $R_{GND}$  resistor.

- 1)  $R_{GND} \leq 600mV / I_{S(on)max}$
- 2)  $R_{GND} \geq (-V_{CC}) / (-I_{GND})$

where  $-I_{GND}$  is the DC reverse ground pin current and can be found in the absolute maximum rating section of the device's datasheet.

Power Dissipation in  $R_{GND}$  (when  $V_{CC} < 0$ : during reverse battery situations) is:

$$P_D = (-V_{CC})^2 / R_{GND}$$

This resistor can be shared amongst several different HSD. Please note that the value of this resistor should be calculated with formula (1) where  $I_{S(on)max}$  becomes the sum of the maximum on-state currents of the different devices.

Please note that if the microprocessor ground is not common with the device ground then the  $R_{GND}$  will produce a shift ( $I_{S(on)max} * R_{GND}$ ) in the input thresholds and the status output values. This shift will vary depending on how many devices are ON in the case of several high side drivers sharing the same  $R_{GND}$ .

If the calculated power dissipation leads to a large resistor or several devices have to share the same resistor then the ST suggests to utilize Solution 2 (see below).

**Solution 2:** A diode ( $D_{GND}$ ) in the ground line.

A resistor ( $R_{GND} = 1k\Omega$ ) should be inserted in parallel to  $D_{GND}$  if the device will be driving an inductive load.

This small signal diode can be safely shared amongst several different HSDs. Also in this case, the presence of the ground network will produce a shift ( $\approx 600mV$ ) in the input thresholds and the status output values if the microprocessor ground is not common with the device ground. This shift will not vary if more than one HSD shares the same diode/resistor network.

Series resistor in INPUT line is also required to prevent that, during battery voltage transient, the current exceeds the Absolute Maximum Rating.

Safest configuration for unused INPUT pin is to leave it unconnected, while unused SENSE pin has to be connected to Ground pin.

**LOAD DUMP PROTECTION**

$D_{id}$  is necessary (Voltage Transient Suppressor) if the load dump peak voltage exceeds  $V_{CC}$  max DC rating. The same applies if the device will be subject to transients on the  $V_{CC}$  line that are greater than the ones shown in the ISO T/R 7637/1 table.



**μC I/Os PROTECTION:**

If a ground protection network is used and negative transient are present on the  $V_{CC}$  line, the control pins will be pulled negative. ST suggests to insert a resistor ( $R_{prot}$ ) in line to prevent the μC I/Os pins to latch-up.

The value of these resistors is a compromise between the leakage current of μC and the current required by the HSD I/Os (Input levels compatibility) with the latch-up limit of μC I/Os.

$$-V_{CCpeak}/I_{latchup} \leq R_{prot} \leq (V_{OH\mu C} - V_{IH} - V_{GND}) / I_{IHmax}$$

Calculation example:

For  $V_{CCpeak} = -100V$  and  $I_{latchup} \geq 20mA$ ;  $V_{OH\mu C} \geq 4.5V$   
 $5k\Omega \leq R_{prot} \leq 65k\Omega$ .

Recommended  $R_{prot}$  value is 10kΩ.

Off State Output Current

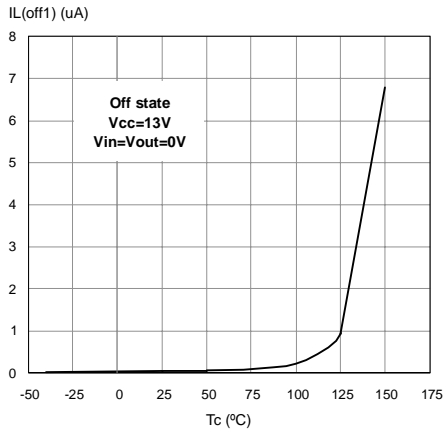

High Level Input Current

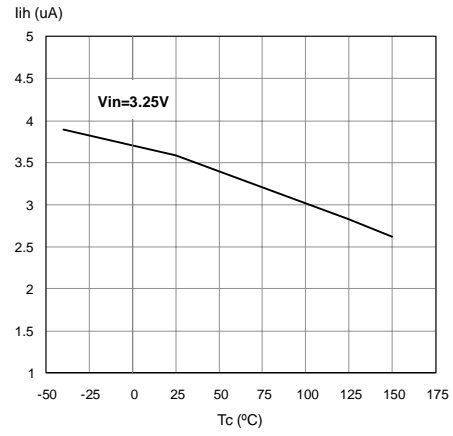

Input Clamp Voltage

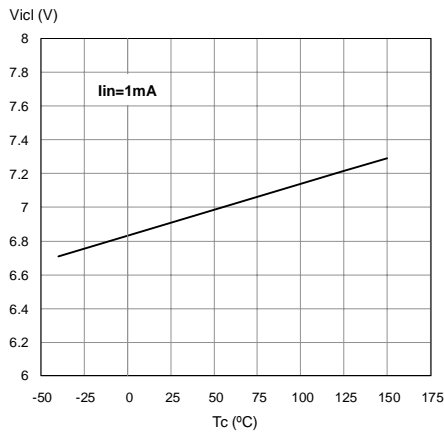

Input High Level

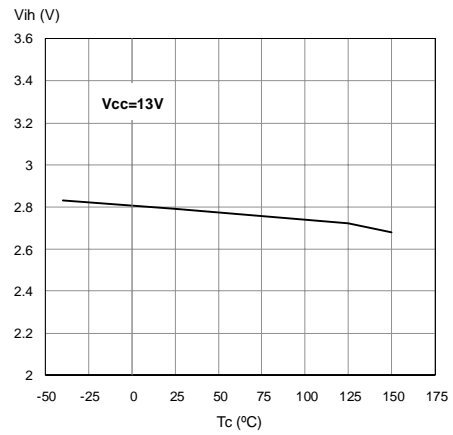

Input Low Level

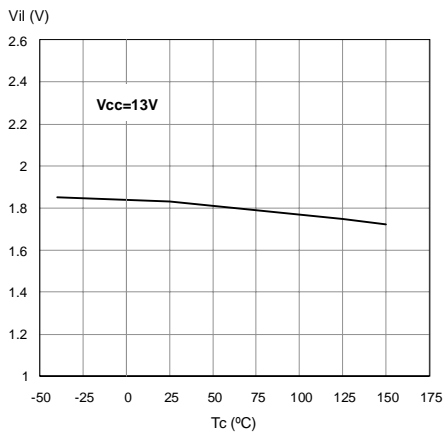

Input Hysteresis Voltage

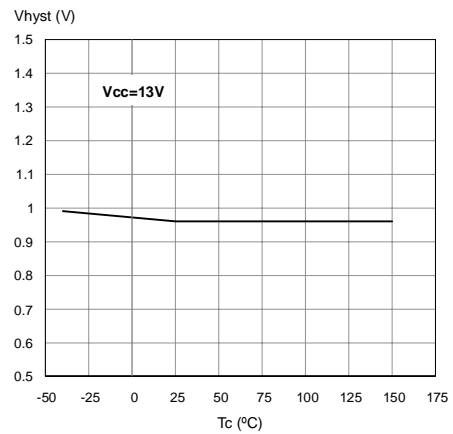

Overvoltage Shutdown

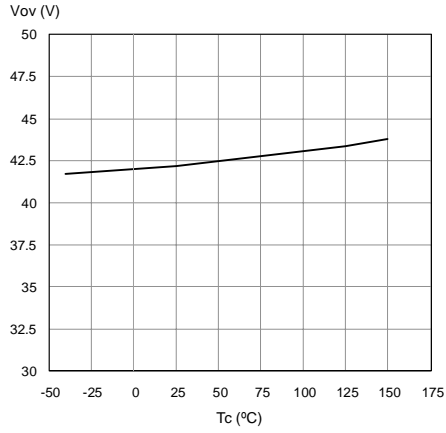

I<sub>LIM</sub> Vs T<sub>case</sub>

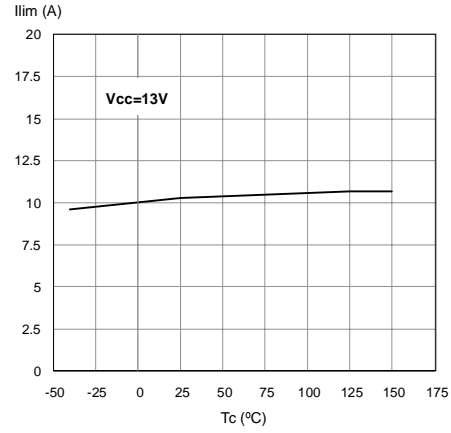

Turn-on Voltage Slope

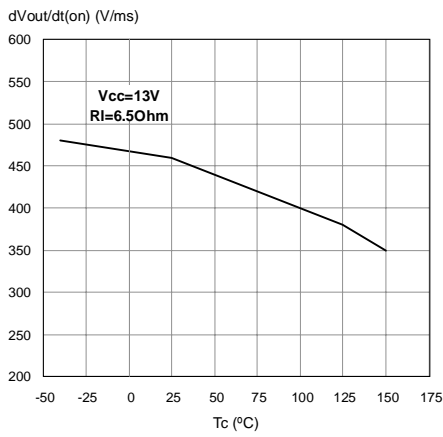

Turn-off Voltage Slope

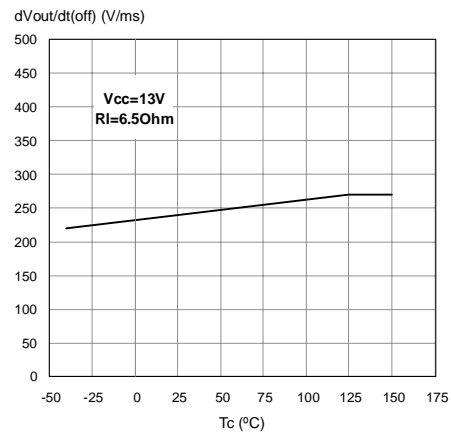

On State Resistance Vs T<sub>case</sub>

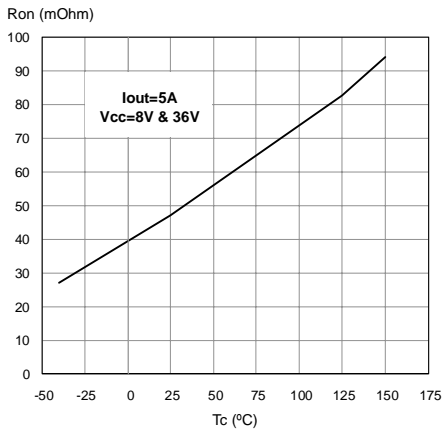

On State Resistance Vs V<sub>CC</sub>

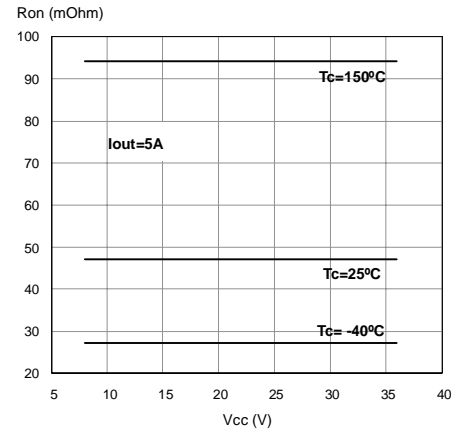

Maximum turn off current versus load inductance

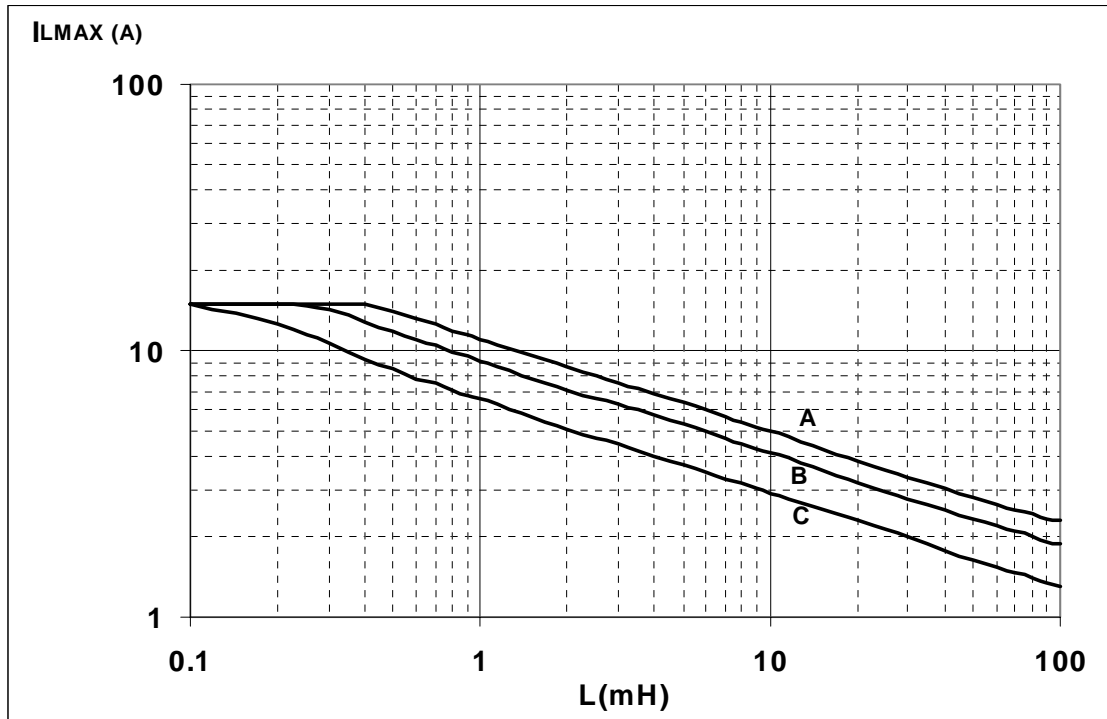

A = Single Pulse at  $T_{jstart}=150^{\circ}C$   
 B= Repetitive pulse at  $T_{jstart}=100^{\circ}C$   
 C= Repetitive Pulse at  $T_{jstart}=125^{\circ}C$

Conditions:

$V_{CC}=13.5V$

Values are generated with  $R_L=0\Omega$

In case of repetitive pulses,  $T_{jstart}$  (at beginning of each demagnetization) of every pulse must not exceed the temperature specified above for curves B and C.

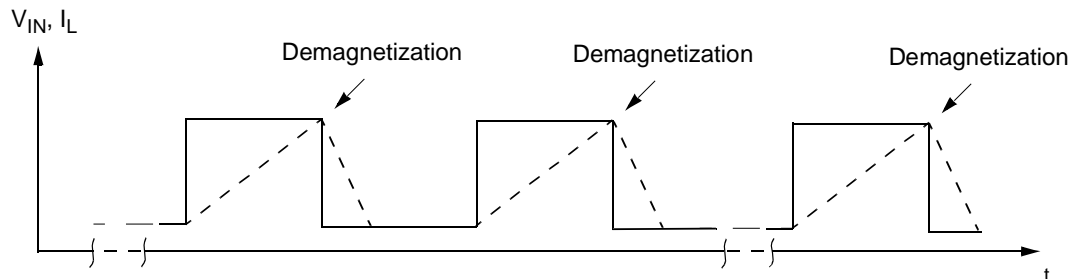

**PowerSO-10™ THERMAL DATA**

**PowerSO-10™ PC Board**

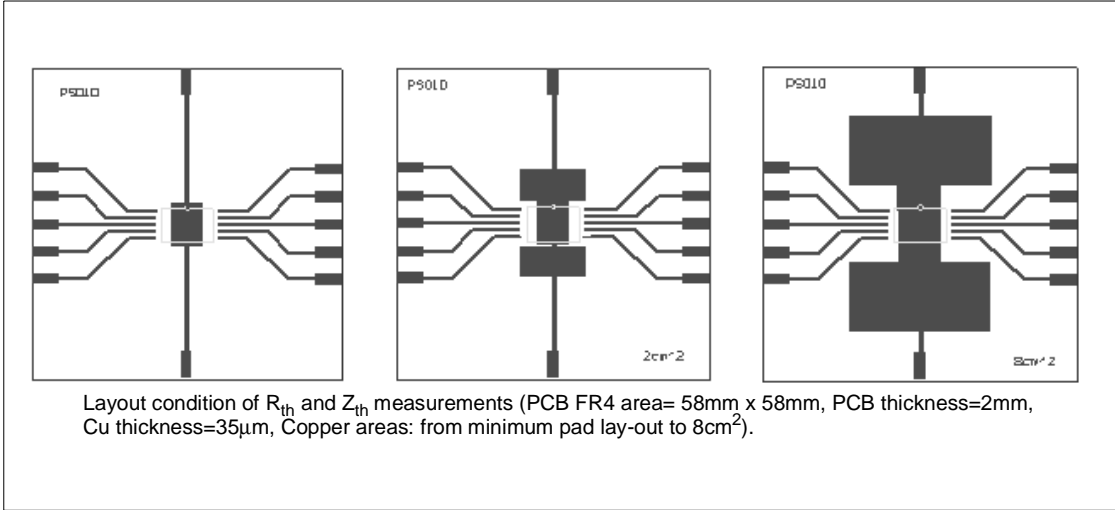

**$R_{thj-amb}$  Vs PCB copper area in open box free air condition**

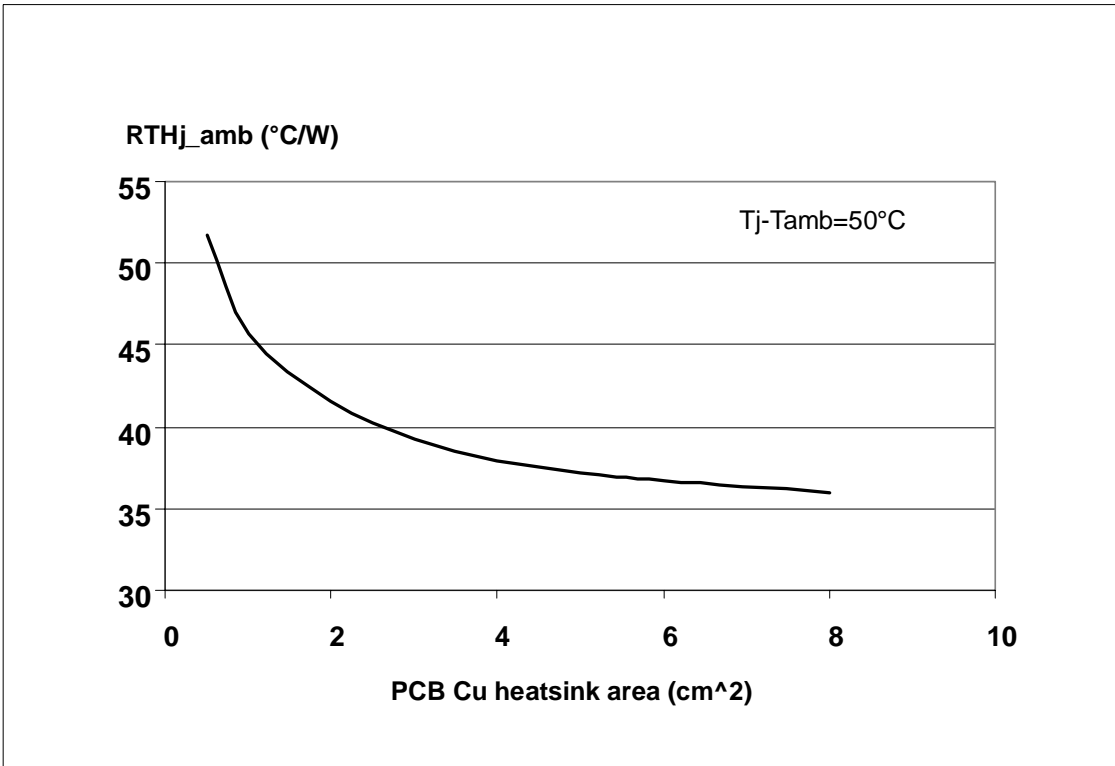

PowerSO-10 Thermal Impedance Junction Ambient Single Pulse

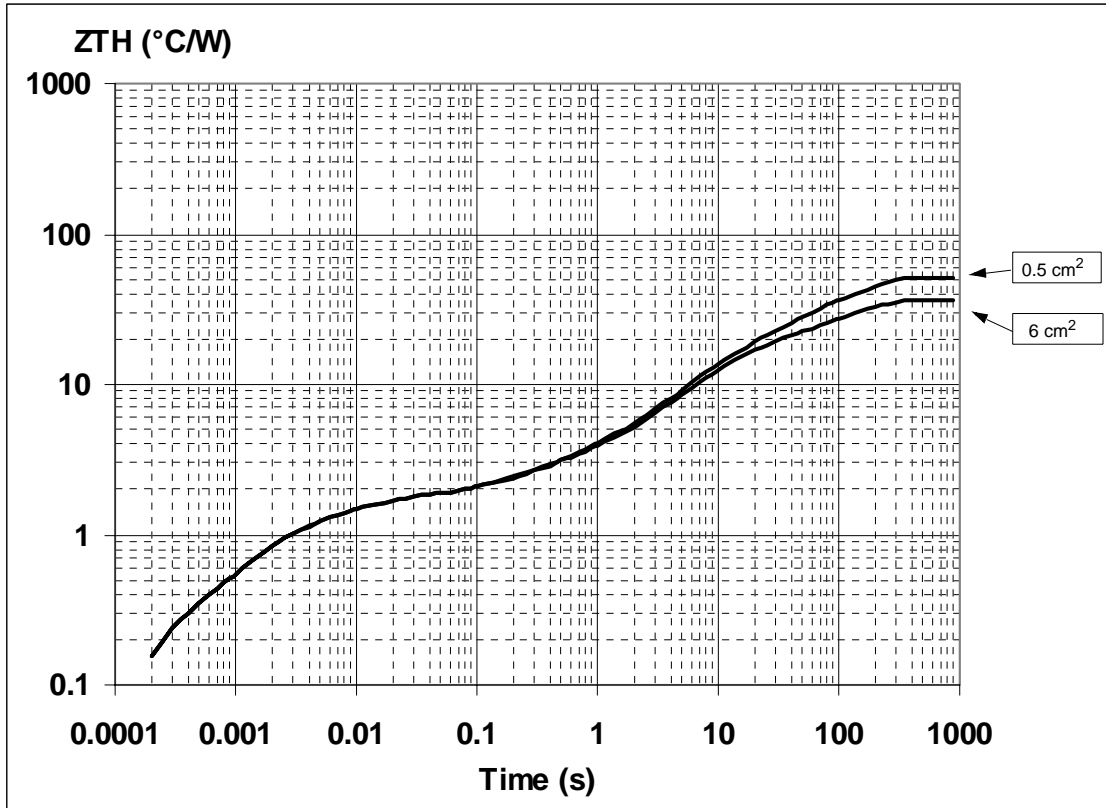

Thermal fitting model of a double channel HSD in PowerSO-10

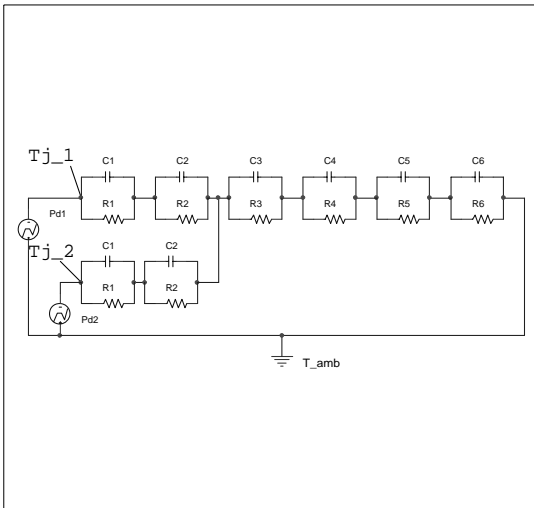

Pulse calculation formula

$$Z_{TH\delta} = R_{TH} \cdot \delta + Z_{THtp}(1 - \delta)$$

where  $\delta = t_p/T$

Thermal Parameter

Area/island (cm <sup>2</sup> )	0.5	6
R1 (°C/W)	0.15	
R2 (°C/W)	0.8	
R3 (°C/W)	0.7	
R4 (°C/W)	0.8	
R5 (°C/W)	12	
R6 (°C/W)	37	22
C1 (W.s/°C)	0.0006	
C2 (W.s/°C)	2.10E-03	
C3 (W.s/°C)	0.013	
C4 (W.s/°C)	0.3	
C5 (W.s/°C)	0.75	
C6 (W.s/°C)	3	5

**PowerSO-10™ MECHANICAL DATA**

DIM.	mm.			inch		
	MIN.	TYP	MAX.	MIN.	TYP.	MAX.
A	3.35		3.65	0.132		0.144
A (*)	3.4		3.6	0.134		0.142
A1	0.00		0.10	0.000		0.004
B	0.40		0.60	0.016		0.024
B (*)	0.37		0.53	0.014		0.021
C	0.35		0.55	0.013		0.022
C (*)	0.23		0.32	0.009		0.0126
D	9.40		9.60	0.370		0.378
D1	7.40		7.60	0.291		0.300
E	9.30		9.50	0.366		0.374
E2	7.20		7.60	0.283		300
E2 (*)	7.30		7.50	0.287		0.295
E4	5.90		6.10	0.232		0.240
E4 (*)	5.90		6.30	0.232		0.248
e		1.27			0.050	
F	1.25		1.35	0.049		0.053
F (*)	1.20		1.40	0.047		0.055
H	13.80		14.40	0.543		0.567
H (*)	13.85		14.35	0.545		0.565
h		0.50			0.002	
L	1.20		1.80	0.047		0.070
L (*)	0.80		1.10	0.031		0.043
α	0°		8°	0°		8°
α (*)	2°		8°	2°		8°

(\*) Muar only POA P013P

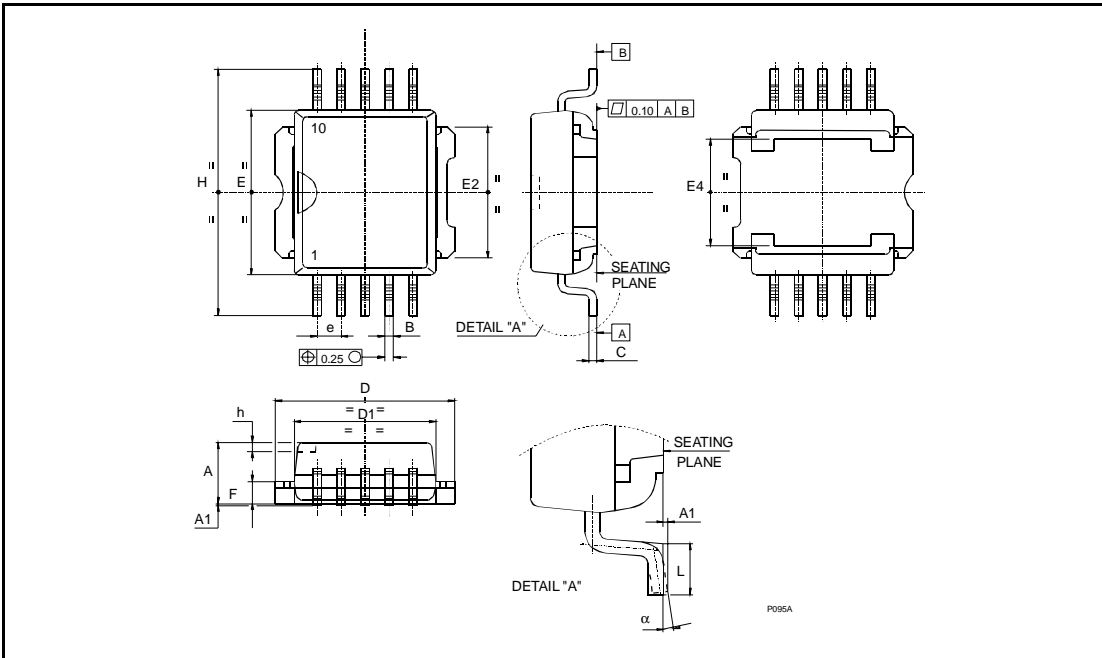

# VND830ASP

## PowerSO-10™ SUGGESTED PAD LAYOUT

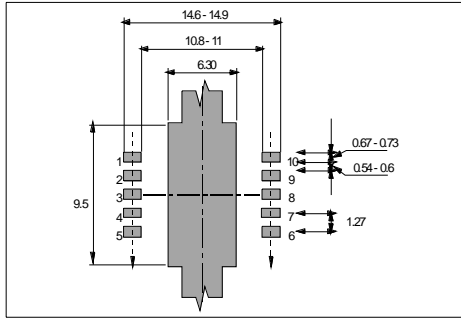

## TUBE SHIPMENT (no suffix)

All dimensions are in mm.

	Base Q.ty	Bulk Q.ty	Tube length (± 0.5)	A	B	C (± 0.1)
<b>Casablanca</b>	50	1000	532	10.4	16.4	0.8
<b>Muar</b>	50	1000	532	4.9	17.2	0.8

## TAPE AND REEL SHIPMENT (suffix "13TR")

### REEL DIMENSIONS

<b>Base Q.ty</b>	600
<b>Bulk Q.ty</b>	600
<b>A (max)</b>	330
<b>B (min)</b>	1.5
<b>C (± 0.2)</b>	13
<b>F</b>	20.2
<b>G (+ 2 / -0)</b>	24.4
<b>N (min)</b>	60
<b>T (max)</b>	30.4

All dimensions are in mm.

### TAPE DIMENSIONS

According to Electronic Industries Association (EIA) Standard 481 rev. A, Feb 1986

<b>Tape width</b>	<b>W</b>	24
<b>Tape Hole Spacing</b>	<b>P0 (± 0.1)</b>	4
<b>Component Spacing</b>	<b>P</b>	24
<b>Hole Diameter</b>	<b>D (± 0.1/-0)</b>	1.5
<b>Hole Diameter</b>	<b>D1 (min)</b>	1.5
<b>Hole Position</b>	<b>F (± 0.05)</b>	11.5
<b>Compartment Depth</b>	<b>K (max)</b>	6.5
<b>Hole Spacing</b>	<b>P1 (± 0.1)</b>	2

All dimensions are in mm.



Information furnished is believed to be accurate and reliable. However, STMicroelectronics assumes no responsibility for the consequences of use of such information nor for any infringement of patents or other rights of third parties which may result from its use. No license is granted by implication or otherwise under any patent or patent rights of STMicroelectronics. Specifications mentioned in this publication are subject to change without notice. This publication supersedes and replaces all information previously supplied. STMicroelectronics products are not authorized for use as critical components in life support devices or systems without express written approval of STMicroelectronics.  
The ST logo is a trademark of STMicroelectronics

© 2003 STMicroelectronics - Printed in ITALY- All Rights Reserved.

STMicroelectronics GROUP OF COMPANIES

Australia - Brazil - Canada - China - Finland - France - Germany - Hong Kong - India - Israel - Italy - Japan - Malaysia -  
Malta - Morocco - Singapore - Spain - Sweden - Switzerland - United Kingdom - U.S.A.

<http://www.st.com>

