

## Iso high side smart power solid state relay

### Features

Type	V <sub>DSS</sub>	R <sub>DS(on)</sub>	I <sub>OUT</sub>	V <sub>CC</sub>
VND05BSP	40 V	0.2 Ω	1.6A	26 V

- Output current (continuous): 9A @ T<sub>c</sub>=85°C
- 5V logic level compatible input
- Thermal shutdown
- Under voltage shutdown
- Open drain diagnostic output
- Inductive load fast demagnetization
- Very low standby power dissipation

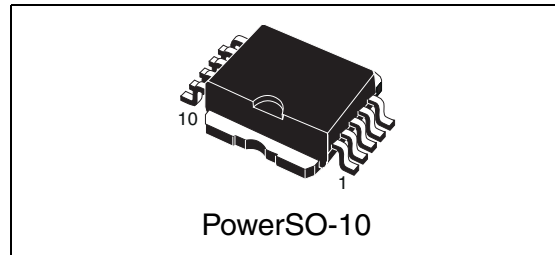

### Description

The VND05BSP is a monolithic device made using STMicroelectronics VIPower Technology, intended for driving resistive or inductive loads with one side grounded.

This device has two channels, and a common diagnostic. Built-in thermal shutdown protects the chip from over temperature and short circuit.

The status output provides an indication of open load in on state, open load in off state, overtemperature conditions and stuck-on to V<sub>CC</sub>.

**Table 1. Device summary**

Package	Order codes	
	Tube	Tape & reel
VND05BSP	VND05BSP	VND05BSP13TR

---

# Contents

<b>1</b>	<b>Block diagram and pin description</b>	<b>5</b>
<b>2</b>	<b>Electrical specifications</b>	<b>6</b>
2.1	Absolute maximum ratings	6
2.2	Thermal data	7
2.3	Electrical characteristics	7
<b>3</b>	<b>Application information</b>	<b>11</b>
3.1	Functional description	12
3.2	Protecting the device against reverse battery	12
<b>4</b>	<b>Package and packing information</b>	<b>13</b>
4.1	ECOPACK® packages	13
4.2	PowerSO-10 mechanical data	13
<b>5</b>	<b>Revision history</b>	<b>15</b>

## List of tables

Table 1.	Device summary . . . . .	1
Table 2.	Absolute maximum ratings . . . . .	6
Table 3.	Thermal data. . . . .	7
Table 4.	Power . . . . .	7
Table 5.	Switching ( $V_{CC}=13V$ ) . . . . .	7
Table 6.	Logic inputs. . . . .	8
Table 7.	Protections and diagnostics . . . . .	8
Table 8.	Truth table. . . . .	10
Table 9.	PowerSO-10 mechanical data . . . . .	14
Table 10.	Document revision history . . . . .	15

## List of figures

Figure 1.	Block diagram . . . . .	5
Figure 2.	Configuration diagram (top view) . . . . .	5
Figure 3.	Current and voltage conventions . . . . .	6
Figure 4.	$I_{L(off)}$ circuit . . . . .	9
Figure 5.	$t_{pol}/t_{povl}$ waveforms . . . . .	9
Figure 6.	Switching time waveforms . . . . .	9
Figure 7.	Waveforms . . . . .	10
Figure 8.	Typical application circuit with a schottky diode for reverse supply protection . . . . .	11
Figure 9.	Typical application circuit with separate signal ground . . . . .	11
Figure 10.	PowerSO-10 package dimensions . . . . .	13

# 1 Block diagram and pin description

Figure 1. Block diagram

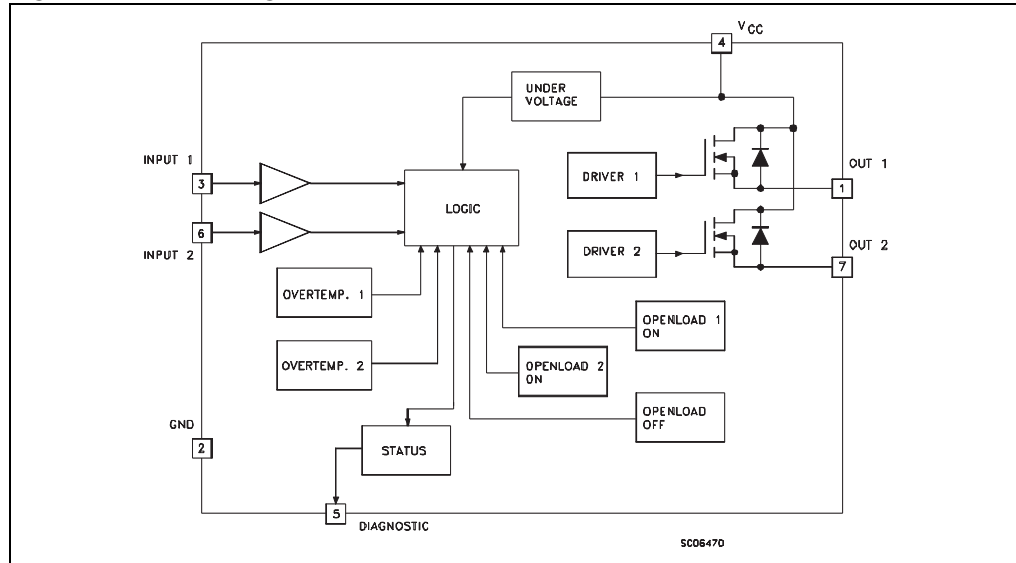
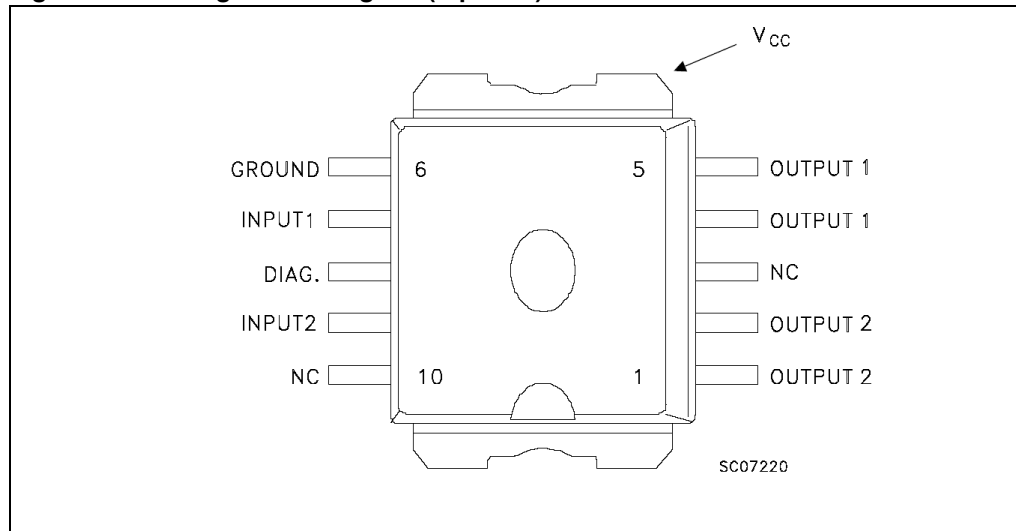
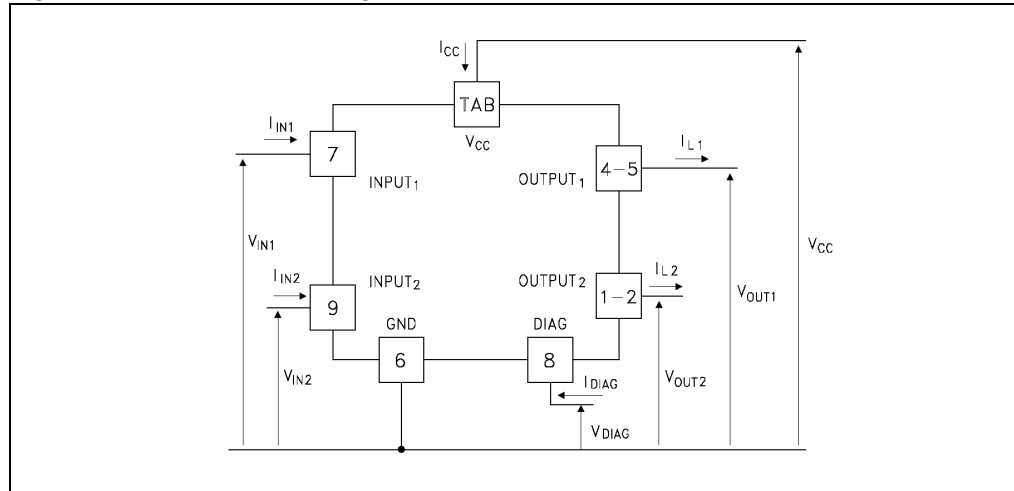

Figure 2. Configuration diagram (top view)



## 2 Electrical specifications

Figure 3. Current and voltage conventions



### 2.1 Absolute maximum ratings

Stressing the device above the rating listed in the “Absolute maximum ratings” table may cause permanent damage to the device. These are stress ratings only and operation of the device at these or any other conditions above those indicated in the operating sections of this specification is not implied. Exposure to Absolute maximum rating conditions for extended periods may affect device reliability. Refer also to the STMicroelectronics sure program and other relevant quality document.

Table 2. Absolute maximum ratings

Symbol	Parameter	Value	Unit
$V_{(BR)DSS}$	Drain-Source breakdown voltage	40	V
$I_{OUT}$	Output current (cont.) at $T_c=85^\circ\text{C}$	9	A
$I_{OUT(RMS)}$	RMS output current at $T_c=85^\circ\text{C}$ and $f > 1\text{Hz}$	9	A
$I_R$	Reverse output current at $T_c=85^\circ\text{C}$	-9	A
$I_{IN}$	Input current	$\pm 10$	mA
$-V_{CC}$	Reverse supply voltage	-4	V
$I_{STAT}$	Status current	$\pm 10$	mA
$V_{ESD}$	Electrostatic discharge (1.5 k $\Omega$ , 100 pF)	2000	V
$P_{tot}$	Power dissipation at $T_c = 25^\circ\text{C}$	59	W
$T_j$	Junction operating temperature	-40 to 150	$^\circ\text{C}$
$T_{stg}$	Storage temperature	-55 to 150	$^\circ\text{C}$

## 2.2 Thermal data

**Table 3. Thermal data**

Symbol	Parameter	Max. value	Unit
$R_{thj-case}$	Thermal resistance junction-case	2.1	°C/W
$R_{thj-amb}$	Thermal resistance junction-ambient	50	°C/W

## 2.3 Electrical characteristics

Values specified in this section are for  $8 < V_{CC} < 16V$ ;  $-40^{\circ}C < T_j < 125^{\circ}C$ , unless otherwise stated.

**Table 4. Power**

Symbol	Parameter	Test conditions	Min.	Typ.	Max.	Unit
$V_{CC}$	Supply voltage		6	13	26	V
$I_n^{(1)}$	Nominal current	$T_C = 85^{\circ}C$ $V_{DS(on)} < 0.5$ $V_{CC} = 13V$	1.6		2.6	A
$R_{on}$	On state resistance	$I_{OUT} = I_n$ ; $V_{CC} = 13V$ $T_j = 25^{\circ}C$	0.13		0.2	$\Omega$
$I_S$	Supply current	Off state $T_j = 25^{\circ}C$ $V_{CC} = 13V$		35	100	$\mu A$
$V_{DS(MAX)}$	Maximum voltage drop	$I_{OUT} = 7.5 A$ ; $T_j = 85^{\circ}C$ $V_{CC} = 13V$	1.44		2.3	V
$R_i$	Output to GND internal impedance	$T_j = 25^{\circ}C$	5	10	20	K $\Omega$

1.  $I_n$  = Nominal current according to ISO definition for high side automotive switch ( $T_c = 85^{\circ}C$  for battery voltage of 13V which produces a voltage drop of 0.5 V).

**Table 5. Switching ( $V_{CC} = 13V$ )**

Symbol	Parameter	Test conditions	Min.	Typ.	Max.	Unit
$t_{d(on)}$	Turn-on delay time of output current	$R_{OUT} = 5.4 \Omega$ (see	5	25	200	$\mu s$
$t_r$	Rise time of output current	$R_{OUT} = 5.4 \Omega$	10	50	180	$\mu s$
$t_{d(off)}$	Turn-off delay time of output current	$R_{OUT} = 5.4 \Omega$	10	75	250	$\mu s$
$t_f$	Fall time of output current	$R_{OUT} = 5.4 \Omega$	10	35	180	$\mu s$
$dV_{OUT}/dt_{(on)}$	Turn-on current slope	$R_{OUT} = 5.4 \Omega$	0.003		0.1	A/ $\mu s$ A/ $\mu s$
$dV_{OUT}/dt_{(off)}$	Turn-off current slope	$R_{OUT} = 5.4 \Omega$	0.005		0.1	A/ $\mu s$ A/ $\mu s$

**Table 6. Logic inputs**

Symbol	Parameter	Test conditions	Min.	Typ.	Max.	Unit
$V_{IL}$	Input low level voltage				1.5	V
$V_{IH}^{(1)}$	Input high level voltage		3.5			V
$V_{I(hyst.)}$	Input hysteresis voltage		0.2	0.9	1.5	V
$I_{IN}$	Input current	$V_{IN} = 5\text{ V}; T_j = 25^\circ\text{C}$		30	100	$\mu\text{A}$
$V_{ICL}$	Input clamp voltage	$I_{IN} = 10\text{ mA}$ $I_{IN} = -10\text{ mA}$	5	6 -0.7	7	V V

1. The  $V_{IH}$  is internally clamped at 6V about. It is possible to connect this pin to an higher voltage via an external resistor calculated to not exceed 10 mA at the input pin.

**Table 7. Protections and diagnostics**

Symbol	Parameter	Test conditions	Min.	Typ.	Max.	Unit
$V_{STAT}$	Status voltage output low	$I_{STAT} = 1.6\text{ mA}$			0.4	V
$V_{USD}$	Under voltage shutdown		3.5	4.5	6	V
$V_{SCL}$	Status clamp voltage	$I_{STAT} = 10\text{ mA}$ $I_{STAT} = -10\text{ mA}$	5	6 -0.7	7	V V
$T_{TSD}$	Thermal shutdown temperature		140	160	180	$^\circ\text{C}$
$T_{TSD(hyst)}$	Thermal shutdown hysteresis				50	$^\circ\text{C}$
$T_R$	Reset temperature		125			$^\circ\text{C}$
$V_{OL}$	Open voltage level	Off-state <sup>(1)</sup>	2.5	4	5	V
$I_{OL}$	Open load current level	On-state	5		180	mA
$t_{povl}^{(2)}$	Status delay					
$t_{pol}^{(2)}$	Status delay					

1.  $I_{OL(off)} = (V_{CC} - V_{OL})/R_{OL}$

2. ISO definition.



Figure 4.  $I_{L(off)}$  circuit

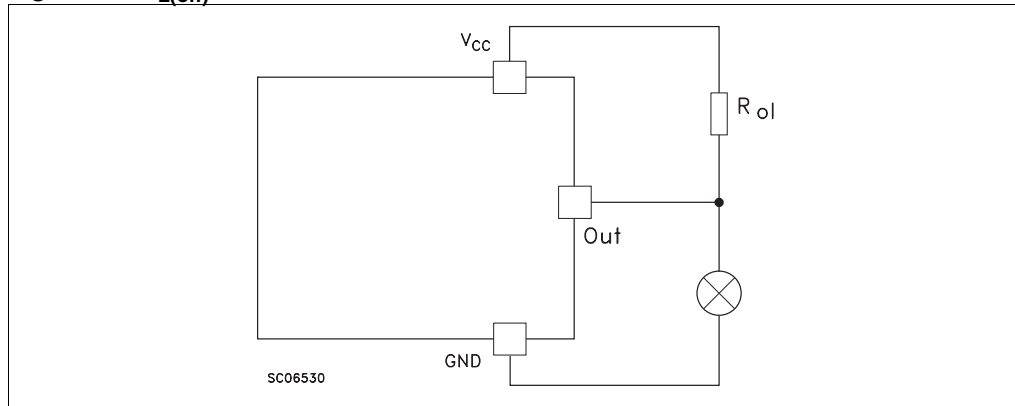

Figure 5.  $t_{pol}/t_{povl}$  waveforms

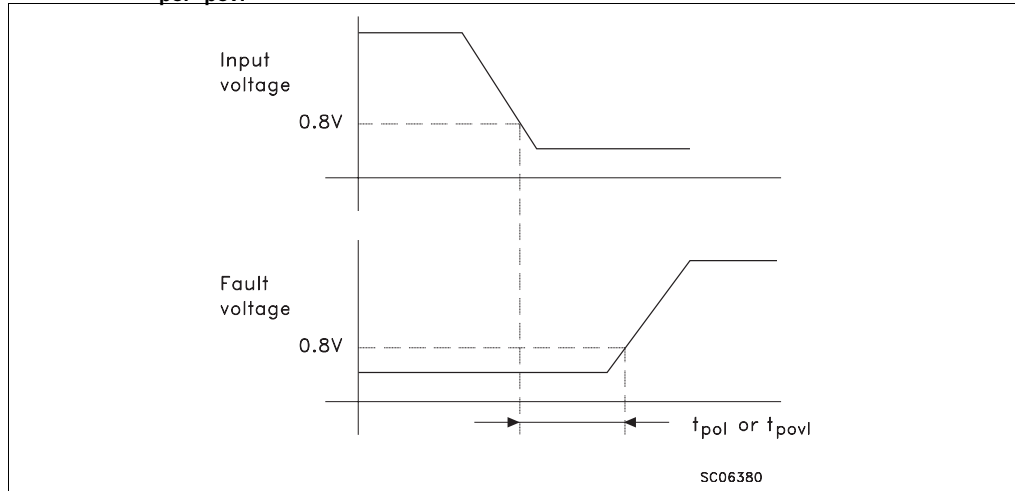
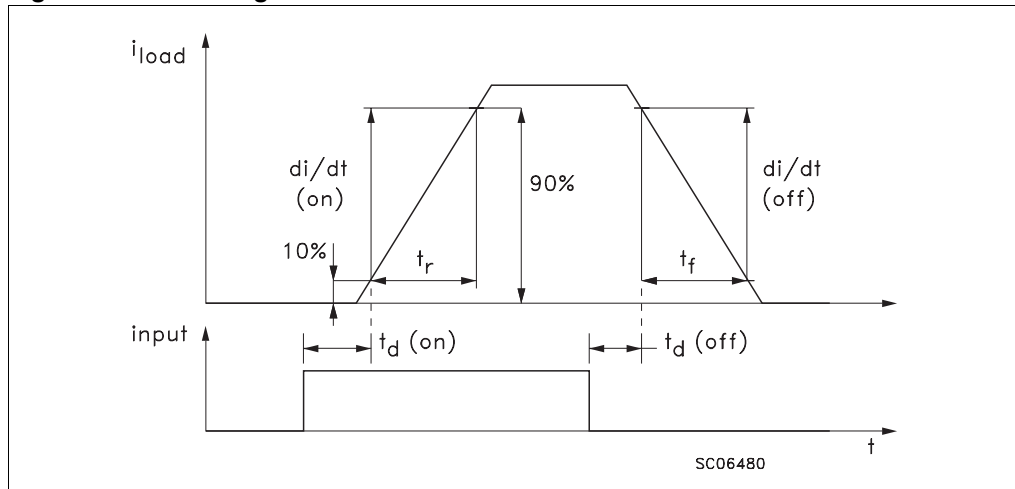

Figure 6. Switching time waveforms



**Table 8. Truth table**

Conditions		Input 1	Input 2	Output 1	Output 2	Diagnostic
Normal operation		L	L	L	L	H
		H	H	H	H	H
Undervoltage		X	X	L	L	H
Thermal shutdown	Channel 1	H	X	L	X	L
	Channel 2	X	H	X	L	L
Openload	Channel 1	H	X	H	X	L
		L	L	L	L	L
	Channel 2	X	H	X	H	L
		L	L	L	L	L
Output shorted to V <sub>CC</sub>	Channel 1	H	X	H	X	L
		L	L	H	L	L
	Channel 2	X	H	X	H	L
		L	L	L	H	L

**Figure 7. Waveforms**

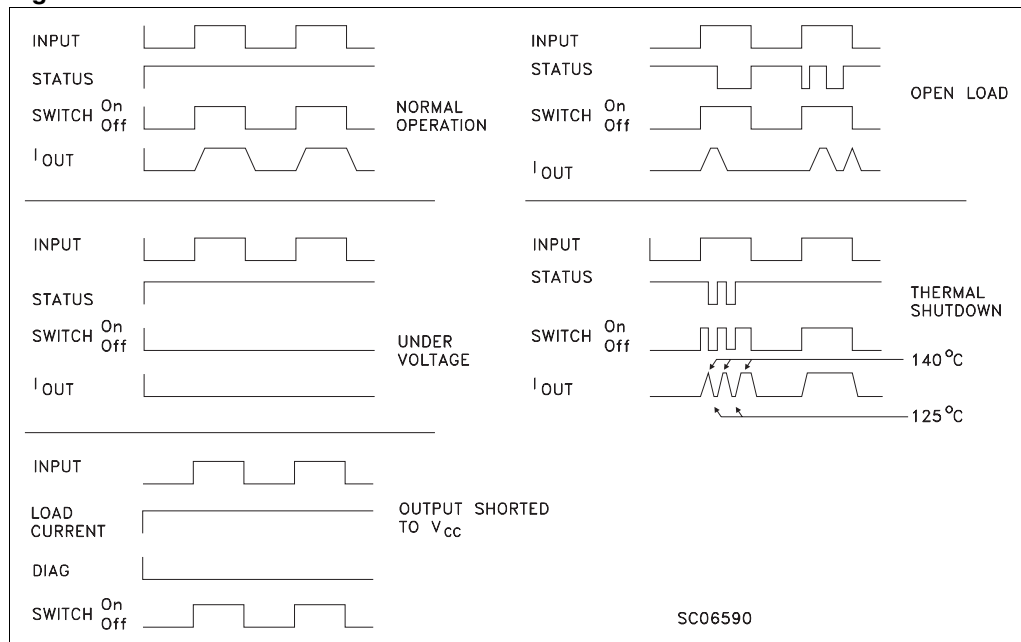

### 3 Application information

**Figure 8.** Typical application circuit with a schottky diode for reverse supply protection

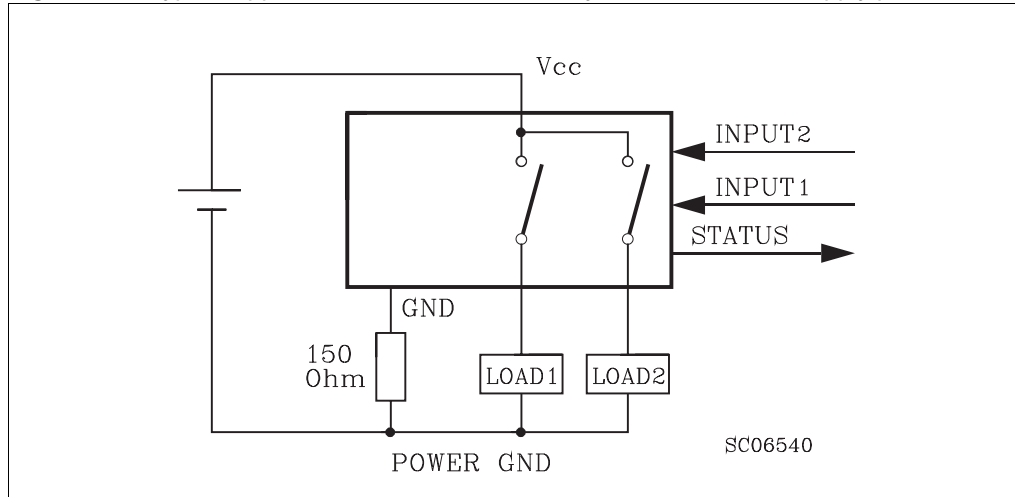

**Figure 9.** Typical application circuit with separate signal ground

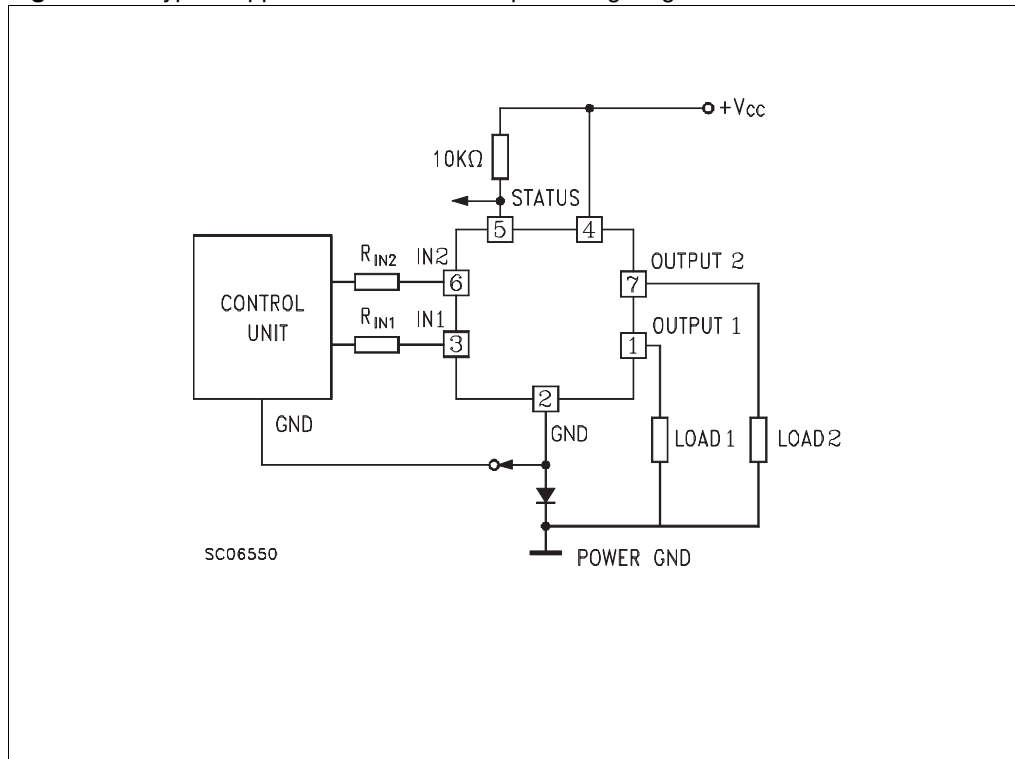

### 3.1 Functional description

The device has a diagnostic output which indicates open load in on-state, open load in off-state, over temperature conditions and stuck-on to  $V_{CC}$ .

From the falling edge of the input signal, the status output, initially low to signal a fault condition (overtemperature or open load on-state), will go back to a high state with a different delay in case of overtemperature ( $t_{povl}$ ) and in case of open open load ( $t_{pol}$ ) respectively.

This feature allows to discriminate the nature of the detected fault. To protect the device against short circuit and over current condition, the thermal protection turns the integrated Power MOSFET off at a minimum junction temperature of 140°C. When this temperature returns to 125°C the switch is automatically turned on again. In short circuit the protection reacts with virtually no delay, the sensor being located inside the Power MOSFET area. An internal function of the devices ensures the fast demagnetization of inductive loads with a typical voltage ( $V_{demag}$ ) of -18V. This function allows to greatly reduces the power dissipation according to the formula:

$$P_{dem} = 0.5 \cdot L_{load} \cdot (I_{load})^2 \cdot [(V_{CC} + V_{demag}) / V_{demag}] \cdot f$$

where  $f$  = switching frequency and  $V_{demag}$  = demagnetization voltage.

The maximum inductance which causes the chip temperature to reach the shut-down temperature in a specified thermal environment is a function of the load current for a fixed  $V_{CC}$ ,  $V_{demag}$  and  $f$  according to the above formula. In this device if the GND pin is disconnected, with  $V_{CC}$  not exceeding 16V, it will switch off.

### 3.2 Protecting the device against reverse battery

The simplest way to protect the device against a continuous reverse battery voltage (-26V) is to insert a Schottky diode between pin 1 (GND) and ground, as shown in the typical application circuit ([Figure 8](#)).

The consequences of the voltage drop across this diode are as follows:

- If the input is pulled to power GND, a negative voltage of  $-V_F$  is seen by the device. ( $V_{IL}$ ,  $V_{IH}$  thresholds and  $V_{STAT}$  are increased by  $V_F$  with respect to power GND).
- The undervoltage shutdown level is increased by  $V_F$ .

If there is no need for the control unit to handle external analog signals referred to the power GND, the best approach is to connect the reference potential of the control unit to node [1] (see [Figure 9](#)), which becomes the common signal GND for the whole control board. In this way no shift of  $V_{IH}$ ,  $V_{IL}$  and  $V_{STAT}$  takes place and no negative voltage appears on the INPUT pin; this solution allows the use of a standard diode, with a breakdown voltage able to handle any ISO normalized negative pulses that occurs in the automotive environment.

## 4 Package and packing information

### 4.1 ECOPACK<sup>®</sup> packages

In order to meet environmental requirements, ST offers these devices in ECOPACK<sup>®</sup> packages. ECOPACK<sup>®</sup> packages are lead-free. The category of Second Level Interconnect is marked on the package and on the inner box label, in compliance with JEDEC Standard JESD97. The maximum ratings related to soldering conditions are also marked on the inner box label.

ECOPACK is an ST trademark. ECOPACK specifications are available at [www.st.com](http://www.st.com).

### 4.2 PowerSO-10 mechanical data

Figure 10. PowerSO-10 package dimensions

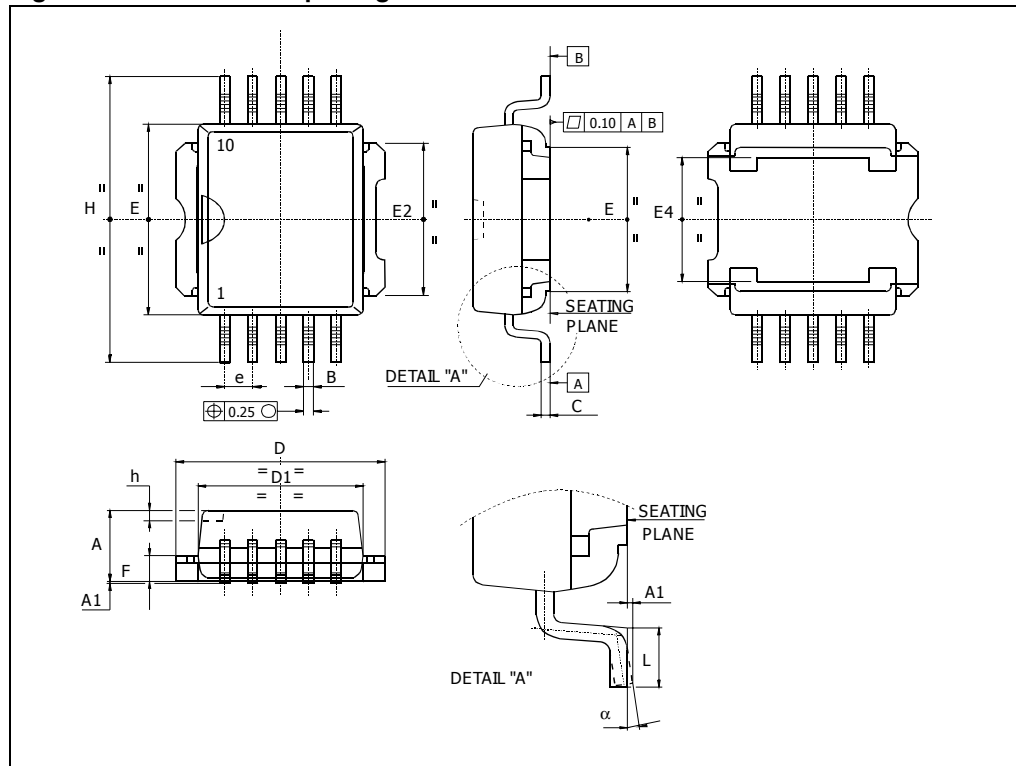

Table 9. PowerSO-10 mechanical data

Dim.	mm		
	Min.	Typ.	Max.
A	3.35		3.65
A <sup>(1)</sup>	3.4		3.6
A1	0		0.10
B	0.40		0.60
B <sup>(1)</sup>	0.37		0.53
C	0.35		0.55
C <sup>(1)</sup>	0.23		0.32
D	9.40		9.60
D1	7.40		7.60
E	9.30		9.50
E2	7.20		7.60
E2 <sup>(1)</sup>	7.30		7.50
E4	5.90		6.10
E4 <sup>(1)</sup>	5.90		6.30
e		1.27	
F	1.25		1.35
F <sup>(1)</sup>	1.20		1.40
H	13.80		14.40
H <sup>(1)</sup>	13.85		14.35
h		0.50	
L	1.20		1.80
L <sup>(1)</sup>	0.80		1.10
$\alpha$	0°		8°
$\alpha$ <sup>(1)</sup>	2°		8°

1. Muar only POA P013P.

## 5 Revision history

Table 10. Document revision history

Date	Revision	Changes
Apr-2001	1	Initial release.
03-May-2006	2	Added contents, list of tables and figures. Added <a href="#">Table 10.: Document revision history</a> .
24-Nov-2008	3	Document reformatted and restructured. Added <a href="#">Table 1.: Device summary</a> . Added <a href="#">ECOPACK® packages</a> information.

**Please Read Carefully:**

Information in this document is provided solely in connection with ST products. STMicroelectronics NV and its subsidiaries ("ST") reserve the right to make changes, corrections, modifications or improvements, to this document, and the products and services described herein at any time, without notice.

All ST products are sold pursuant to ST's terms and conditions of sale.

Purchasers are solely responsible for the choice, selection and use of the ST products and services described herein, and ST assumes no liability whatsoever relating to the choice, selection or use of the ST products and services described herein.

No license, express or implied, by estoppel or otherwise, to any intellectual property rights is granted under this document. If any part of this document refers to any third party products or services it shall not be deemed a license grant by ST for the use of such third party products or services, or any intellectual property contained therein or considered as a warranty covering the use in any manner whatsoever of such third party products or services or any intellectual property contained therein.

**UNLESS OTHERWISE SET FORTH IN ST'S TERMS AND CONDITIONS OF SALE ST DISCLAIMS ANY EXPRESS OR IMPLIED WARRANTY WITH RESPECT TO THE USE AND/OR SALE OF ST PRODUCTS INCLUDING WITHOUT LIMITATION IMPLIED WARRANTIES OF MERCHANTABILITY, FITNESS FOR A PARTICULAR PURPOSE (AND THEIR EQUIVALENTS UNDER THE LAWS OF ANY JURISDICTION), OR INFRINGEMENT OF ANY PATENT, COPYRIGHT OR OTHER INTELLECTUAL PROPERTY RIGHT.**

**UNLESS EXPRESSLY APPROVED IN WRITING BY AN AUTHORIZED ST REPRESENTATIVE, ST PRODUCTS ARE NOT RECOMMENDED, AUTHORIZED OR WARRANTED FOR USE IN MILITARY, AIR CRAFT, SPACE, LIFE SAVING, OR LIFE SUSTAINING APPLICATIONS, NOR IN PRODUCTS OR SYSTEMS WHERE FAILURE OR MALFUNCTION MAY RESULT IN PERSONAL INJURY, DEATH, OR SEVERE PROPERTY OR ENVIRONMENTAL DAMAGE. ST PRODUCTS WHICH ARE NOT SPECIFIED AS "AUTOMOTIVE GRADE" MAY ONLY BE USED IN AUTOMOTIVE APPLICATIONS AT USER'S OWN RISK.**

Resale of ST products with provisions different from the statements and/or technical features set forth in this document shall immediately void any warranty granted by ST for the ST product or service described herein and shall not create or extend in any manner whatsoever, any liability of ST.

ST and the ST logo are trademarks or registered trademarks of ST in various countries.

Information in this document supersedes and replaces all information previously supplied.

The ST logo is a registered trademark of STMicroelectronics. All other names are the property of their respective owners.

© 2008 STMicroelectronics - All rights reserved

STMicroelectronics group of companies

Australia - Belgium - Brazil - Canada - China - Czech Republic - Finland - France - Germany - Hong Kong - India - Israel - Italy - Japan - Malaysia - Malta - Morocco - Singapore - Spain - Sweden - Switzerland - United Kingdom - United States of America

[www.st.com](http://www.st.com)