

MOS INTEGRATED CIRCUIT

μ PD44324085-A, 44324095-A, 44324185-A, 44324365-A

36M-BIT DDR II SRAM SEPARATE I/O 2-WORD BURST OPERATION

Description

The μ PD44324085-A is a 4,194,304-word by 8-bit, the μ PD44324095-A is a 4,194,304-word by 9-bit, the μ PD44324185-A is a 2,097,152-word by 18-bit and the μ PD44324365-A is a 1,048,576-word by 36-bit synchronous double data rate static RAM fabricated with advanced CMOS technology using full CMOS six-transistor memory cell.

The μ PD44324085-A, μ PD44324095-A, μ PD44324185-A and μ PD44324365-A integrate unique synchronous peripheral circuitry and a burst counter. All input registers controlled by an input clock pair (K and K#) are latched on the positive edge of K and K#.

These products are suitable for application which require synchronous operation, high speed, low voltage, high density and wide bit configuration.

These products are packaged in 165-pin PLASTIC BGA.

Features

- 1.8 ± 0.1 V power supply
- 165-pin PLASTIC BGA package (13 x 15)
- HSTL interface
- PLL circuitry for wide output data valid window and future frequency scaling
- Separate independent read and write data ports
- DDR read or write operation initiated each cycle
- Pipelined double data rate operation
- Separate data input/output bus
- Two-tick burst for low DDR transaction size
- Two input clocks (K and K#) for precise DDR timing at clock rising edges only
- Two output clocks (C and C#) for precise flight time and clock skew matching-clock and data delivered together to receiving device
- Internally self-timed write control
- Clock-stop capability. Normal operation is restored in 1,024 cycles after clock is resumed.
- User programmable impedance output
- Fast clock cycle time : 3.7 ns (270 MHz), 4.0 ns (250 MHz), 5.0 ns (200 MHz)
- Simple control logic for easy depth expansion
- JTAG boundary scan
- Operating ambient temperature: Commercial $T_A = 0$ to $+70^\circ\text{C}$ (-E37, -E40, -E50)
Industrial $T_A = -40$ to $+85^\circ\text{C}$ (-E40Y, -E50Y)

The information in this document is subject to change without notice. Before using this document, please confirm that this is the latest version.
Not all products and/or types are available in every country. Please check with an NEC Electronics sales representative for availability and additional information.

Ordering Information

(1) Operating Ambient Temperature T_A = 0 to +70°C

Part number	Cycle Time ns	Clock Frequency MHz	Organization (word x bit)	Package	Operating Ambient Temperature	
μPD44324085F5-E37-EQ2-A	3.7	270	4M x 8-bit	165-pin PLASTIC BGA (13 x 15)	Commercial (T _A = 0 to +70°C)	
μPD44324085F5-E40-EQ2-A	4.0	250				
μPD44324085F5-E50-EQ2-A	5.0	200				
μPD44324095F5-E37-EQ2-A	3.7	270	4M x 9-bit	Lead-free		
μPD44324095F5-E40-EQ2-A	4.0	250				
μPD44324095F5-E50-EQ2-A	5.0	200				
μPD44324185F5-E37-EQ2-A	3.7	270	2M x 18-bit			
μPD44324185F5-E40-EQ2-A	4.0	250				
μPD44324185F5-E50-EQ2-A	5.0	200				
μPD44324365F5-E37-EQ2-A	3.7	270	1M x 36-bit			
μPD44324365F5-E40-EQ2-A	4.0	250				
μPD44324365F5-E50-EQ2-A	5.0	200				

Remarks 1. QDR Consortium standard package size is 13 x 15 and 15 x 17.

The footprint is commonly used.

2. Products with -A at the end of the part number are lead-free products.

(2) Operating Ambient Temperature T_A = -40 to +85°C

Part number	Cycle Time ns	Clock Frequency MHz	Organization (word x bit)	Package	Operating Ambient Temperature
μPD44324085F5-E40Y-EQ2-A	4.0	250	4M x 8-bit	165-pin PLASTIC BGA (13 x 15) Lead-free	Industrial (T _A = -40 to +85°C)
μPD44324085F5-E50Y-EQ2-A	5.0	200			
μPD44324095F5-E40Y-EQ2-A	4.0	250	4M x 9-bit		
μPD44324095F5-E50Y-EQ2-A	5.0	200			
μPD44324185F5-E40Y-EQ2-A	4.0	250	2M x 18-bit		
μPD44324185F5-E50Y-EQ2-A	5.0	200			

Remarks 1. QDR Consortium standard package size is 13 x 15 and 15 x 17.

The footprint is commonly used.

2. Products with -A at the end of the part number are lead-free products.

Pin Configurations

165-pin PLASTIC BGA (13 x 15)

(Top View)

[μPD44324085-A]

4M x 8-bit

	1	2	3	4	5	6	7	8	9	10	11
A	CQ#	V _{SS}	A	R, W#	NW1#	K#	NC	LD#	A	A	CQ
B	NC	NC	NC	A	NC	K	NW0#	A	NC	NC	Q3
C	NC	NC	NC	V _{SS}	A	A	A	V _{SS}	NC	NC	D3
D	NC	D4	NC	V _{SS}	V _{SS}	V _{SS}	V _{SS}	V _{SS}	NC	NC	NC
E	NC	NC	Q4	V _{DDQ}	V _{SS}	V _{SS}	V _{SS}	V _{DDQ}	NC	D2	Q2
F	NC	NC	NC	V _{DDQ}	V _{DD}	V _{SS}	V _{DD}	V _{DDQ}	NC	NC	NC
G	NC	D5	Q5	V _{DDQ}	V _{DD}	V _{SS}	V _{DD}	V _{DDQ}	NC	NC	NC
H	DLL#	V _{REF}	V _{DDQ}	V _{DDQ}	V _{DD}	V _{SS}	V _{DD}	V _{DDQ}	V _{DDQ}	V _{REF}	ZQ
J	NC	NC	NC	V _{DDQ}	V _{DD}	V _{SS}	V _{DD}	V _{DDQ}	NC	Q1	D1
K	NC	NC	NC	V _{DDQ}	V _{DD}	V _{SS}	V _{DD}	V _{DDQ}	NC	NC	NC
L	NC	Q6	D6	V _{DDQ}	V _{SS}	V _{SS}	V _{SS}	V _{DDQ}	NC	NC	Q0
M	NC	NC	NC	V _{SS}	V _{SS}	V _{SS}	V _{SS}	V _{SS}	NC	NC	D0
N	NC	D7	NC	V _{SS}	A	A	A	V _{SS}	NC	NC	NC
P	NC	NC	Q7	A	A	C	A	A	NC	NC	NC
R	TDO	TCK	A	A	A	C#	A	A	A	TMS	TDI

- | | | | |
|------------|-----------------------------|------------------|------------------------------|
| A | : Address inputs | TMS | : IEEE 1149.1 Test input |
| D0 to D7 | : Data inputs | TDI | : IEEE 1149.1 Test input |
| Q0 to Q7 | : Data outputs | TCK | : IEEE 1149.1 Clock input |
| LD# | : Synchronous load | TDO | : IEEE 1149.1 Test output |
| R, W# | : Read Write input | V _{REF} | : HSTL input reference input |
| NW0#, NW1# | : Nibble Write data select | V _{DD} | : Power Supply |
| K, K# | : Input clock | V _{DDQ} | : Power Supply |
| C, C# | : Output clock | V _{SS} | : Ground |
| CQ, CQ# | : Echo clock | NC | : No connection |
| ZQ | : Output impedance matching | | |
| DLL# | : DLL/PLL disable | | |

- Remarks**
1. xxx# indicates active LOW signal.
 2. Refer to **Package Drawing** for the index mark.
 3. 2A and 7A are expansion addresses: 2A for 72Mb and 7A for 144Mb.
2A of this product can also be used as NC.

165-pin PLASTIC BGA (13 x 15)

(Top View)

[μPD44324095-A]

4M x 9-bit

	1	2	3	4	5	6	7	8	9	10	11
A	CQ#	V _{SS}	A	R, W#	NC	K#	NC	LD#	A	A	CQ
B	NC	NC	NC	A	NC	K	BW0#	A	NC	NC	Q4
C	NC	NC	NC	V _{SS}	A	A	A	V _{SS}	NC	NC	D4
D	NC	D5	NC	V _{SS}	V _{SS}	V _{SS}	V _{SS}	V _{SS}	NC	NC	NC
E	NC	NC	Q5	V _{DDQ}	V _{SS}	V _{SS}	V _{SS}	V _{DDQ}	NC	D3	Q3
F	NC	NC	NC	V _{DDQ}	V _{DD}	V _{SS}	V _{DD}	V _{DDQ}	NC	NC	NC
G	NC	D6	Q6	V _{DDQ}	V _{DD}	V _{SS}	V _{DD}	V _{DDQ}	NC	NC	NC
H	DLL#	V _{REF}	V _{DDQ}	V _{DDQ}	V _{DD}	V _{SS}	V _{DD}	V _{DDQ}	V _{DDQ}	V _{REF}	ZQ
J	NC	NC	NC	V _{DDQ}	V _{DD}	V _{SS}	V _{DD}	V _{DDQ}	NC	Q2	D2
K	NC	NC	NC	V _{DDQ}	V _{DD}	V _{SS}	V _{DD}	V _{DDQ}	NC	NC	NC
L	NC	Q7	D7	V _{DDQ}	V _{SS}	V _{SS}	V _{SS}	V _{DDQ}	NC	NC	Q1
M	NC	NC	NC	V _{SS}	V _{SS}	V _{SS}	V _{SS}	V _{SS}	NC	NC	D1
N	NC	D8	NC	V _{SS}	A	A	A	V _{SS}	NC	NC	NC
P	NC	NC	Q8	A	A	C	A	A	NC	D0	Q0
R	TDO	TCK	A	A	A	C#	A	A	A	TMS	TDI

- | | | | |
|----------|-----------------------------|------------------|------------------------------|
| A | : Address inputs | TMS | : IEEE 1149.1 Test input |
| D0 to D8 | : Data inputs | TDI | : IEEE 1149.1 Test input |
| Q0 to Q8 | : Data outputs | TCK | : IEEE 1149.1 Clock input |
| LD# | : Synchronous load | TDO | : IEEE 1149.1 Test output |
| R, W# | : Read Write input | V _{REF} | : HSTL input reference input |
| BW0# | : Byte Write data select | V _{DD} | : Power Supply |
| K, K# | : Input clock | V _{DDQ} | : Power Supply |
| C, C# | : Output clock | V _{SS} | : Ground |
| CQ, CQ# | : Echo clock | NC | : No connection |
| ZQ | : Output impedance matching | | |
| DLL# | : DLL/PLL disable | | |

- Remarks**
1. xxx# indicates active LOW signal.
 2. Refer to **Package Drawing** for the index mark.
 3. 2A and 7A are expansion addresses: 2A for 72Mb and 7A for 144Mb.
2A of this product can also be used as NC.

165-pin PLASTIC BGA (13 x 15)

(Top View)

[μPD44324185-A]

2M x 18-bit

	1	2	3	4	5	6	7	8	9	10	11
A	CQ#	V _{SS}	A	R, W#	BW1#	K#	NC	LD#	A	V _{SS}	CQ
B	NC	Q9	D9	A	NC	K	BW0#	A	NC	NC	Q8
C	NC	NC	D10	V _{SS}	A	A	A	V _{SS}	NC	Q7	D8
D	NC	D11	Q10	V _{SS}	V _{SS}	V _{SS}	V _{SS}	V _{SS}	NC	NC	D7
E	NC	NC	Q11	V _{DDQ}	V _{SS}	V _{SS}	V _{SS}	V _{DDQ}	NC	D6	Q6
F	NC	Q12	D12	V _{DDQ}	V _{DD}	V _{SS}	V _{DD}	V _{DDQ}	NC	NC	Q5
G	NC	D13	Q13	V _{DDQ}	V _{DD}	V _{SS}	V _{DD}	V _{DDQ}	NC	NC	D5
H	DLL#	V _{REF}	V _{DDQ}	V _{DDQ}	V _{DD}	V _{SS}	V _{DD}	V _{DDQ}	V _{DDQ}	V _{REF}	ZQ
J	NC	NC	D14	V _{DDQ}	V _{DD}	V _{SS}	V _{DD}	V _{DDQ}	NC	Q4	D4
K	NC	NC	Q14	V _{DDQ}	V _{DD}	V _{SS}	V _{DD}	V _{DDQ}	NC	D3	Q3
L	NC	Q15	D15	V _{DDQ}	V _{SS}	V _{SS}	V _{SS}	V _{DDQ}	NC	NC	Q2
M	NC	NC	D16	V _{SS}	V _{SS}	V _{SS}	V _{SS}	V _{SS}	NC	Q1	D2
N	NC	D17	Q16	V _{SS}	A	A	A	V _{SS}	NC	NC	D1
P	NC	NC	Q17	A	A	C	A	A	NC	D0	Q0
R	TDO	TCK	A	A	A	C#	A	A	A	TMS	TDI

- | | | | |
|------------|-----------------------------|------------------|------------------------------|
| A | : Address inputs | TMS | : IEEE 1149.1 Test input |
| D0 to D17 | : Data inputs | TDI | : IEEE 1149.1 Test input |
| Q0 to Q17 | : Data outputs | TCK | : IEEE 1149.1 Clock input |
| LD# | : Synchronous load | TDO | : IEEE 1149.1 Test output |
| R, W# | : Read Write input | V _{REF} | : HSTL input reference input |
| BW0#, BW1# | : Byte Write data select | V _{DD} | : Power Supply |
| K, K# | : Input clock | V _{DDQ} | : Power Supply |
| C, C# | : Output clock | V _{SS} | : Ground |
| CQ, CQ# | : Echo clock | NC | : No connection |
| ZQ | : Output impedance matching | | |
| DLL# | : DLL/PLL disable | | |

- Remarks**
1. xxx# indicates active LOW signal.
 2. Refer to **Package Drawing** for the index mark.
 3. 2A and 10A are expansion addresses: 10A for 72Mb and 2A for 144Mb.
2A and 10A of this product can also be used as NC.

165-pin PLASTIC BGA (13 x 15)

(Top View)

[μPD44324365-A]

1M x 36-bit

	1	2	3	4	5	6	7	8	9	10	11
A	CQ#	V _{SS}	NC	R, W#	BW2#	K#	BW1#	LD#	A	V _{SS}	CQ
B	Q27	Q18	D18	A	BW3#	K	BW0#	A	D17	Q17	Q8
C	D27	Q28	D19	V _{SS}	A	A	A	V _{SS}	D16	Q7	D8
D	D28	D20	Q19	V _{SS}	V _{SS}	V _{SS}	V _{SS}	V _{SS}	Q16	D15	D7
E	Q29	D29	Q20	V _{DDQ}	V _{SS}	V _{SS}	V _{SS}	V _{DDQ}	Q15	D6	Q6
F	Q30	Q21	D21	V _{DDQ}	V _{DD}	V _{SS}	V _{DD}	V _{DDQ}	D14	Q14	Q5
G	D30	D22	Q22	V _{DDQ}	V _{DD}	V _{SS}	V _{DD}	V _{DDQ}	Q13	D13	D5
H	DLL#	V _{REF}	V _{DDQ}	V _{DDQ}	V _{DD}	V _{SS}	V _{DD}	V _{DDQ}	V _{DDQ}	V _{REF}	ZQ
J	D31	Q31	D23	V _{DDQ}	V _{DD}	V _{SS}	V _{DD}	V _{DDQ}	D12	Q4	D4
K	Q32	D32	Q23	V _{DDQ}	V _{DD}	V _{SS}	V _{DD}	V _{DDQ}	Q12	D3	Q3
L	Q33	Q24	D24	V _{DDQ}	V _{SS}	V _{SS}	V _{SS}	V _{DDQ}	D11	Q11	Q2
M	D33	Q34	D25	V _{SS}	V _{SS}	V _{SS}	V _{SS}	V _{SS}	D10	Q1	D2
N	D34	D26	Q25	V _{SS}	A	A	A	V _{SS}	Q10	D9	D1
P	Q35	D35	Q26	A	A	C	A	A	Q9	D0	Q0
R	TDO	TCK	A	A	A	C#	A	A	A	TMS	TDI

A	: Address inputs	TMS	: IEEE 1149.1 Test input
D0 to D35	: Data inputs	TDI	: IEEE 1149.1 Test input
Q0 to Q35	: Data outputs	TCK	: IEEE 1149.1 Clock input
LD#	: Synchronous load	TDO	: IEEE 1149.1 Test output
R, W#	: Read Write input	V _{REF}	: HSTL input reference input
BW0# to BW3#	: Byte Write data select	V _{DD}	: Power Supply
K, K#	: Input clock	V _{DDQ}	: Power Supply
C, C#	: Output clock	V _{SS}	: Ground
CQ, CQ#	: Echo clock	NC	: No connection
ZQ	: Output impedance matching		
DLL#	: DLL/PLL disable		

- Remarks**
1. xxx# indicates active LOW signal.
 2. Refer to **Package Drawing** for the index mark.
 3. 3A and 10A are expansion addresses: 3A for 72Mb and 10A for 144Mb.
2A and 10A of this product can also be used as NC.

Pin Identification

(1/2)

Symbol	Description
A	Synchronous Address Inputs: These inputs are registered and must meet the setup and hold times around the rising edge of K. All transactions operate on a burst of two words (one clock period of bus activity). These inputs are ignored when device is deselected, i.e., NOP (LD# = HIGH).
D0 to Dxx	Synchronous Data Inputs: Input data must meet setup and hold times around the rising edges of K and K# during WRITE operations. See Pin Configurations for ball site location of individual signals. x8 device uses D0 to D7. x9 device uses D0 to D8. x18 device uses D0 to D17. x36 device uses D0 to D35.
Q0 to Qxx	Synchronous Data Outputs: Output data is synchronized to the respective C and C# or to K and K# rising edges if C and C# are tied HIGH. Data is output in synchronization with C and C# (or K and K#), depending on the LD# and R, W# command. See Pin Configurations for ball site location of individual signals. x8 device uses Q0 to Q7. x9 device uses Q0 to Q8. x18 device uses Q0 to Q17. x36 device uses Q0 to Q35.
LD#	Synchronous Load: This input is brought LOW when a bus cycle sequence is to be defined. This definition includes address and read/write direction. All transactions operate on a burst of 2 data (one clock period of bus activity).
R, W#	Synchronous Read/Write Input: When LD# is LOW, this input designates the access type (READ when R, W# is HIGH, WRITE when R, W# is LOW) for the loaded address. R, W# must meet the setup and hold times around the rising edge of K.
BWx# NWx#	Synchronous Byte Writes (Nibble Writes on x8): When LOW these inputs cause their respective byte or nibble to be registered and written during WRITE cycles. These signals must meet setup and hold times around the rising edges of K and K# for each of the two rising edges comprising the WRITE cycle. See Pin Configurations for signal to data relationships. x8 device uses NW0#, NW1#. x9 device uses BW0#. x18 device uses BW0#, BW1#. x36 device uses BW0# to BW3#. See Byte Write Operation for relation between BWx#, NWx# and Dxx.
K, K#	Input Clock: This input clock pair registers address and control inputs on the rising edge of K, and registers data on the rising edge of K and the rising edge of K#. K# is ideally 180 degrees out of phase with K. All synchronous inputs must meet setup and hold times around the clock rising edges.
C, C#	Output Clock: This clock pair provides a user controlled means of tuning device output data. The rising edge of C# is used as the output timing reference for first output data. The rising edge of C is used as the output reference for second output data. Ideally, #C is 180 degrees out of phase with C. When use of K and K# as the reference instead of C and C#, then fixed C and C# to HIGH. Operation cannot be guaranteed unless C and C# are fixed to HIGH (i.e. toggle of C and C#)

(2/2)

Symbol	Description
CQ, CQ#	Synchronous Echo Clock Outputs. The rising edges of these outputs are tightly matched to the synchronous data outputs and can be used as a data valid indication. These signals run freely and do not stop when Q tristates. If C and C# are stopped (if K and K# are stopped in the single clock mode), CQ and CQ# will also stop.
ZQ	Output Impedance Matching Input: This input is used to tune the device outputs to the system data bus impedance. Q, CQ and CQ# output impedance are set to $0.2 \times RQ$, where RQ is a resistor from this bump to ground. The output impedance can be minimized by directly connect ZQ to V _{DDQ} . This pin cannot be connected directly to GND or left unconnected. The output impedance is adjusted every 1,024 cycles upon power-up to account for drifts in supply voltage and temperature. After replacement for a resistor, the new output impedance is reset by implementing power-on sequence.
DLL#	DLL/PLL Disable: When debugging the system or board, the operation can be performed at a clock frequency slower than TKHKH (MAX.) without the DLL/PLL circuit being used, if DLL# = LOW. The AC/DC characteristics cannot be guaranteed. For normal operation, DLL# must be HIGH and it can be connected to V _{DDQ} through a 10 kΩ or less resistor.
TMS TDI	IEEE 1149.1 Test Inputs: 1.8 V I/O level. These balls may be left Not Connected if the JTAG function is not used in the circuit.
TCK	IEEE 1149.1 Clock Input: 1.8 V I/O level. This pin must be tied to V _{SS} if the JTAG function is not used in the circuit.
TDO	IEEE 1149.1 Test Output: 1.8 V I/O level.
V _{REF}	HSTL Input Reference Voltage: Nominally V _{DDQ} /2. Provides a reference voltage for the input buffers.
V _{DD}	Power Supply: 1.8 V nominal. See Recommended DC Operating Conditions and DC Characteristics for range.
V _{DDQ}	Power Supply: Isolated Output Buffer Supply. Nominally 1.5 V. 1.8 V is also permissible. See Recommended DC Operating Conditions and DC Characteristics for range.
V _{SS}	Power Supply: Ground
NC	No Connect: These signals are not connected internally.

Block Diagram

[μPD44324085-A]

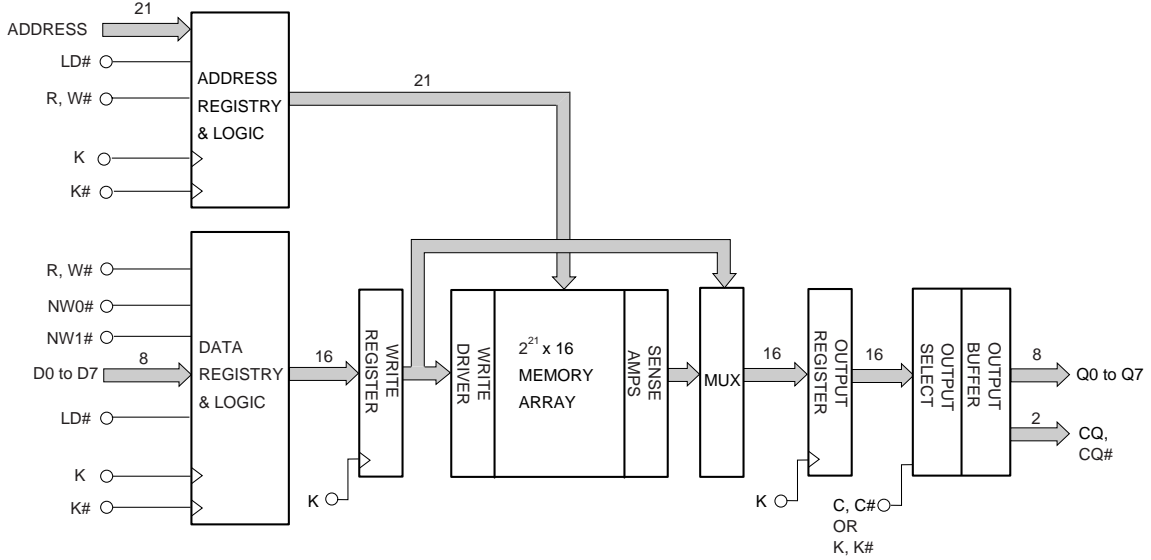

[μPD44324095-A]

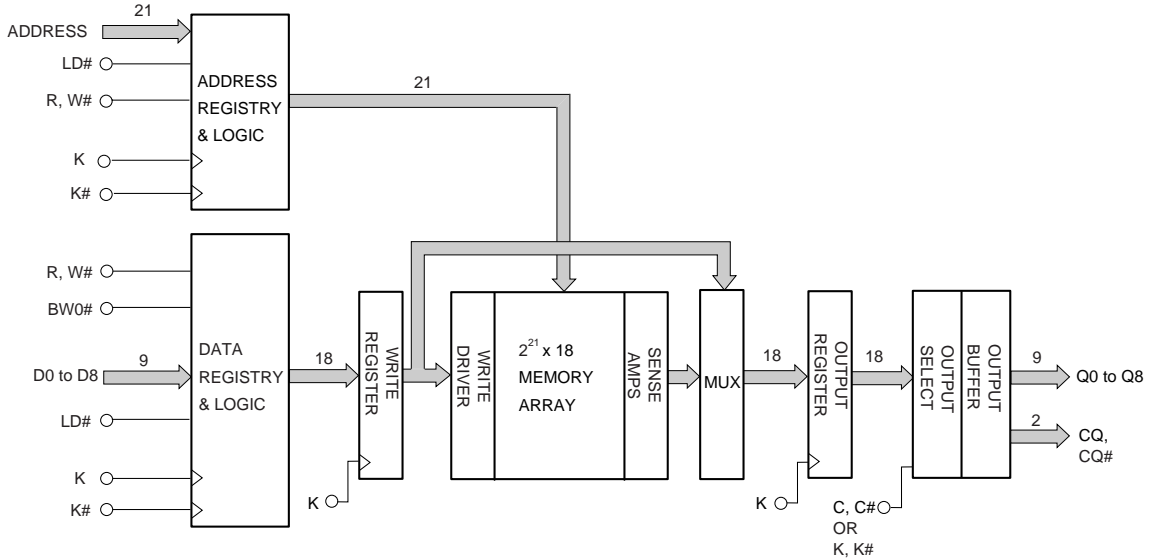

[μPD44324185-A]

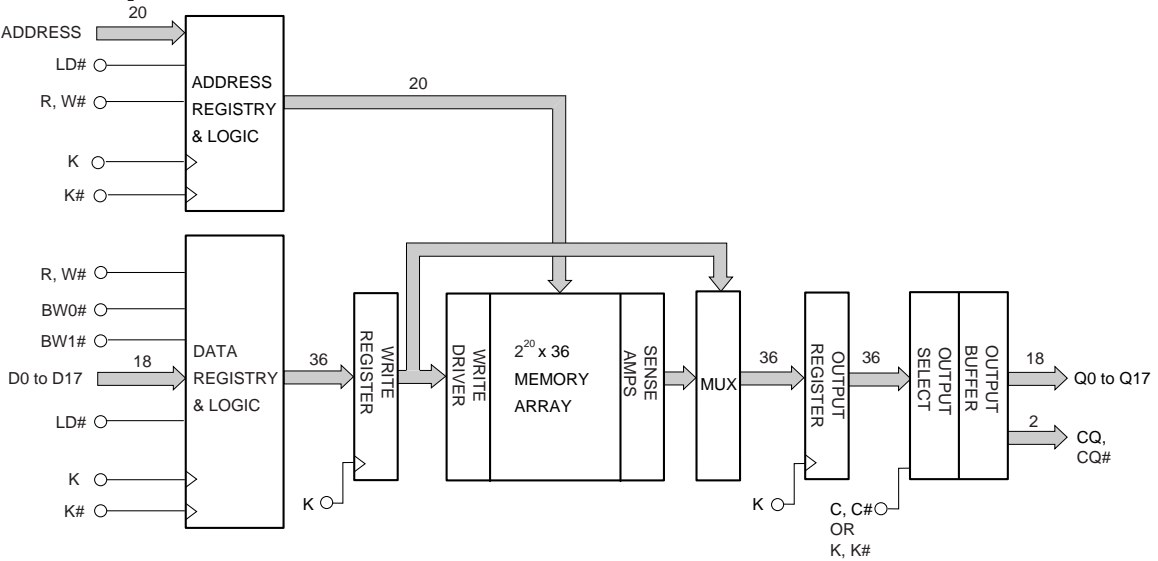

[μ PD44324365-A]

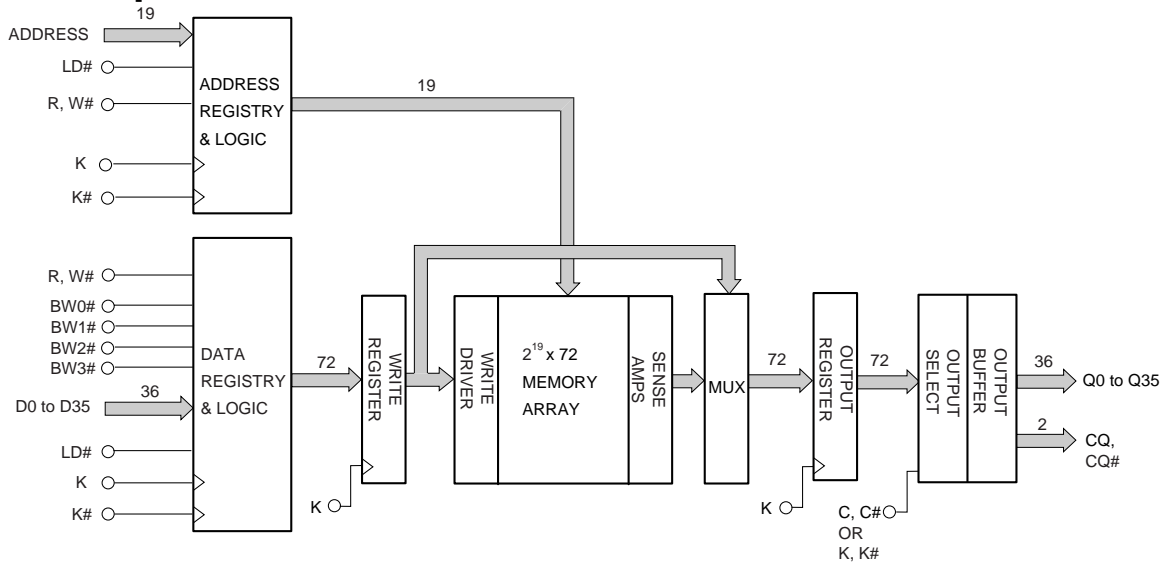

Power-on Sequence

The following two timing charts show the recommended power-on sequence, i.e., when starting the clock after V_{DD}/V_{DDQ} stable and when starting the clock before V_{DD}/V_{DDQ} stable.

1. Clock starts after V_{DD}/V_{DDQ} stable

The clock is supplied from a controller.

(a)

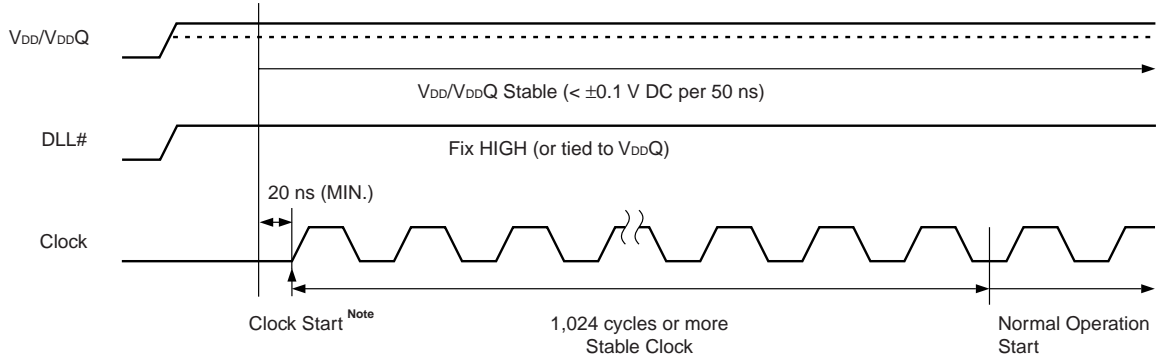

Note Input a stable clock from the start.

(b)

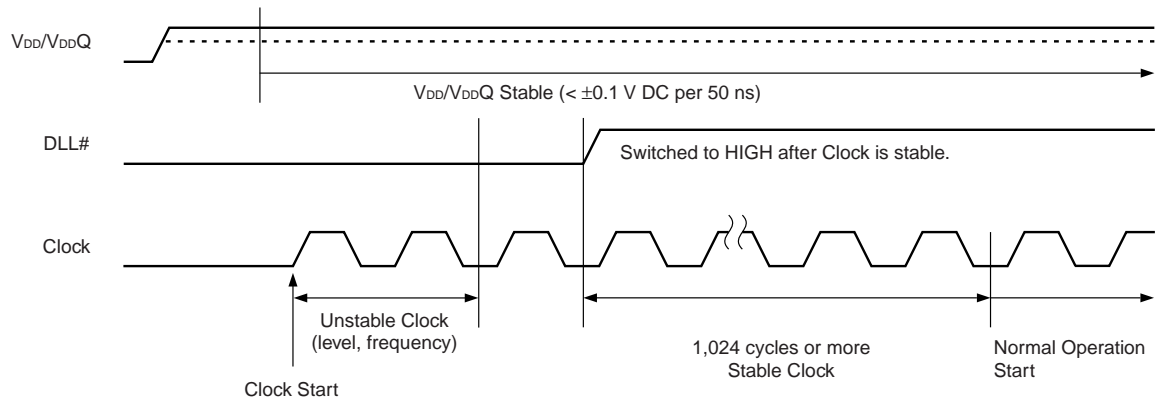

(c)

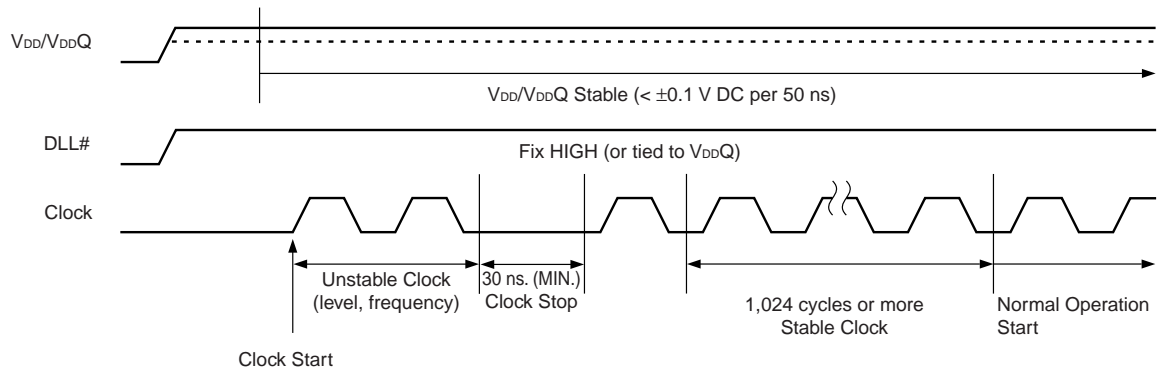

2. Clock starts before V_{DD}/V_{DDQ} stable

The clock is supplied from a clock generator.

(a)

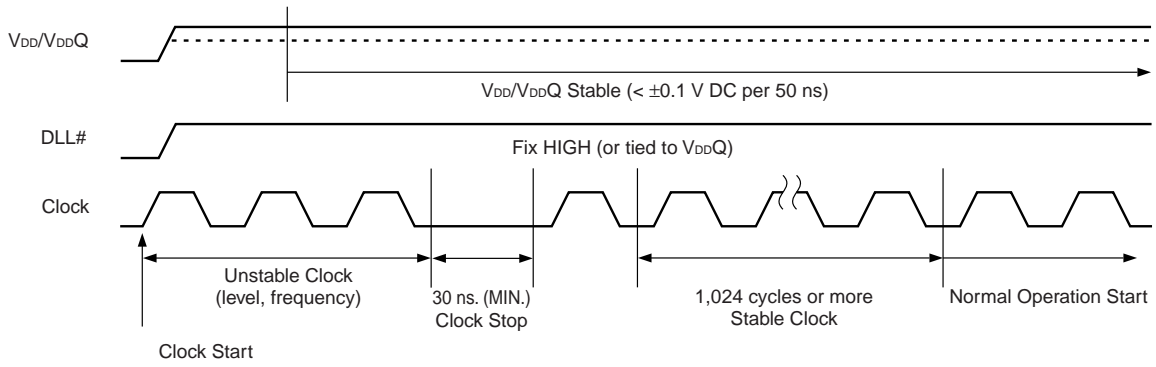

(b)

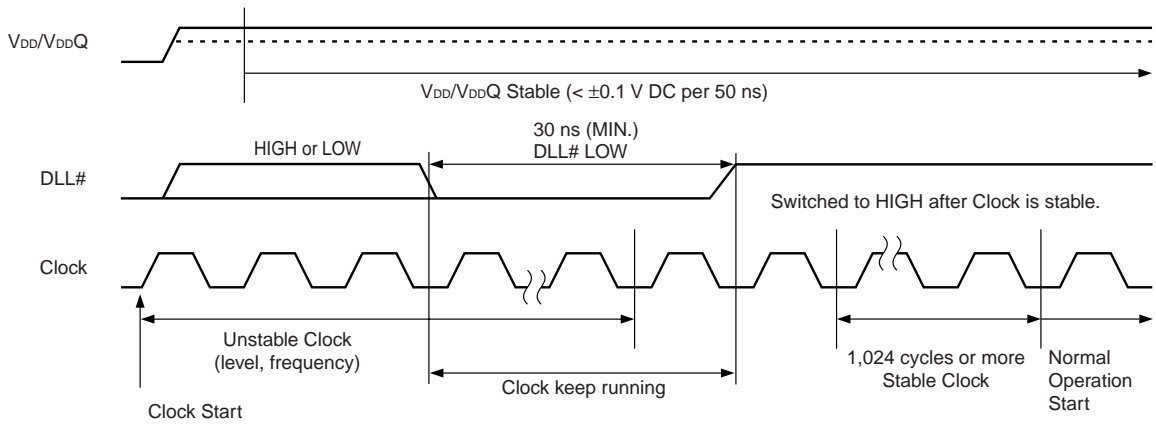

Truth Table

Operation	LD#	R, W#	CLK	D or Q		
WRITE cycle Load address, input write data on two consecutive K and K# rising edge	L	L	L → H	Data in		
				Input data	D(A+0)	D(A+1)
				Input clock	K(t+1) ↑	K#(t+1) ↑
READ cycle Load address, read data on two consecutive C and C# rising edge	L	H	L → H	Data out		
				Output data	Q(A+0)	Q(A+1)
				Output clock	C#(t+1) ↑	C(t+2) ↑
NOP (No operation)	H	X	L → H	D = X, Q = High-Z		
Clock stop	X	X	Stopped	Previous state		

- Remarks**
1. H : HIGH, L : LOW, × : don't care, ↑ : rising edge.
 2. Data inputs are registered at K and K# rising edges. Data outputs are delivered at C and C# rising edges except if C and C# are HIGH then Data outputs are delivered at K and K# rising edges.
 3. All control inputs in the truth table must meet setup/hold times around the rising edge (LOW to HIGH) of K. All control inputs are registered during the rising edge of K.
 4. This device contains circuitry that ensure the outputs to be in high impedance during power-up.
 5. Refer to state diagram and timing diagrams for clarification.
 6. It is recommended that K = K# = C = C# when clock is stopped. This is not essential but permits most rapid restart by overcoming transmission line charging symmetrically.

Byte Write Operation

[μPD44324085-A]

Operation	K	K#	NW0#	NW1#
Write D0 to D7	L → H	–	0	0
	–	L → H	0	0
Write D0 to D3	L → H	–	0	1
	–	L → H	0	1
Write D4 to D7	L → H	–	1	0
	–	L → H	1	0
Write nothing	L → H	–	1	1
	–	L → H	1	1

- Remarks**
1. H : HIGH, L : LOW, → : rising edge.
 2. Assumes a WRITE cycle was initiated. NW0# and NW1# can be altered for any portion of the BURST WRITE operation provided that the setup and hold requirements are satisfied.

[μPD44324095-A]

Operation	K	K#	BW0#
Write D0 to D8	L → H	–	0
	–	L → H	0
Write nothing	L → H	–	1
	–	L → H	1

- Remarks**
1. H : HIGH, L : LOW, → : rising edge.
 2. Assumes a WRITE cycle was initiated. BW0# can be altered for any portion of the BURST WRITE operation provided that the setup and hold requirements are satisfied.

[μPD44324185-A]

Operation	K	K#	BW0#	BW1#
Write D0 to D17	L → H	–	0	0
	–	L → H	0	0
Write D0 to D8	L → H	–	0	1
	–	L → H	0	1
Write D9 to D17	L → H	–	1	0
	–	L → H	1	0
Write nothing	L → H	–	1	1
	–	L → H	1	1

- Remarks**
1. H : HIGH, L : LOW, → : rising edge.
 2. Assumes a WRITE cycle was initiated. BW0# and BW1# can be altered for any portion of the BURST WRITE operation provided that the setup and hold requirements are satisfied.

[μPD44324365-A]

Operation	K	K#	BW0#	BW1#	BW2#	BW3#
Write D0 to D35	L → H	-	0	0	0	0
	-	L → H	0	0	0	0
Write D0 to D8	L → H	-	0	1	1	1
	-	L → H	0	1	1	1
Write D9 to D17	L → H	-	1	0	1	1
	-	L → H	1	0	1	1
Write D18 to D26	L → H	-	1	1	0	1
	-	L → H	1	1	0	1
Write D27 to D35	L → H	-	1	1	1	0
	-	L → H	1	1	1	0
Write nothing	L → H	-	1	1	1	1
	-	L → H	1	1	1	1

Remarks 1. H : HIGH, L : LOW, → : rising edge.

- Assumes a WRITE cycle was initiated. BW0# to BW3# can be altered for any portion of the BURST WRITE operation provided that the setup and hold requirements are satisfied.

Bus Cycle State Diagram

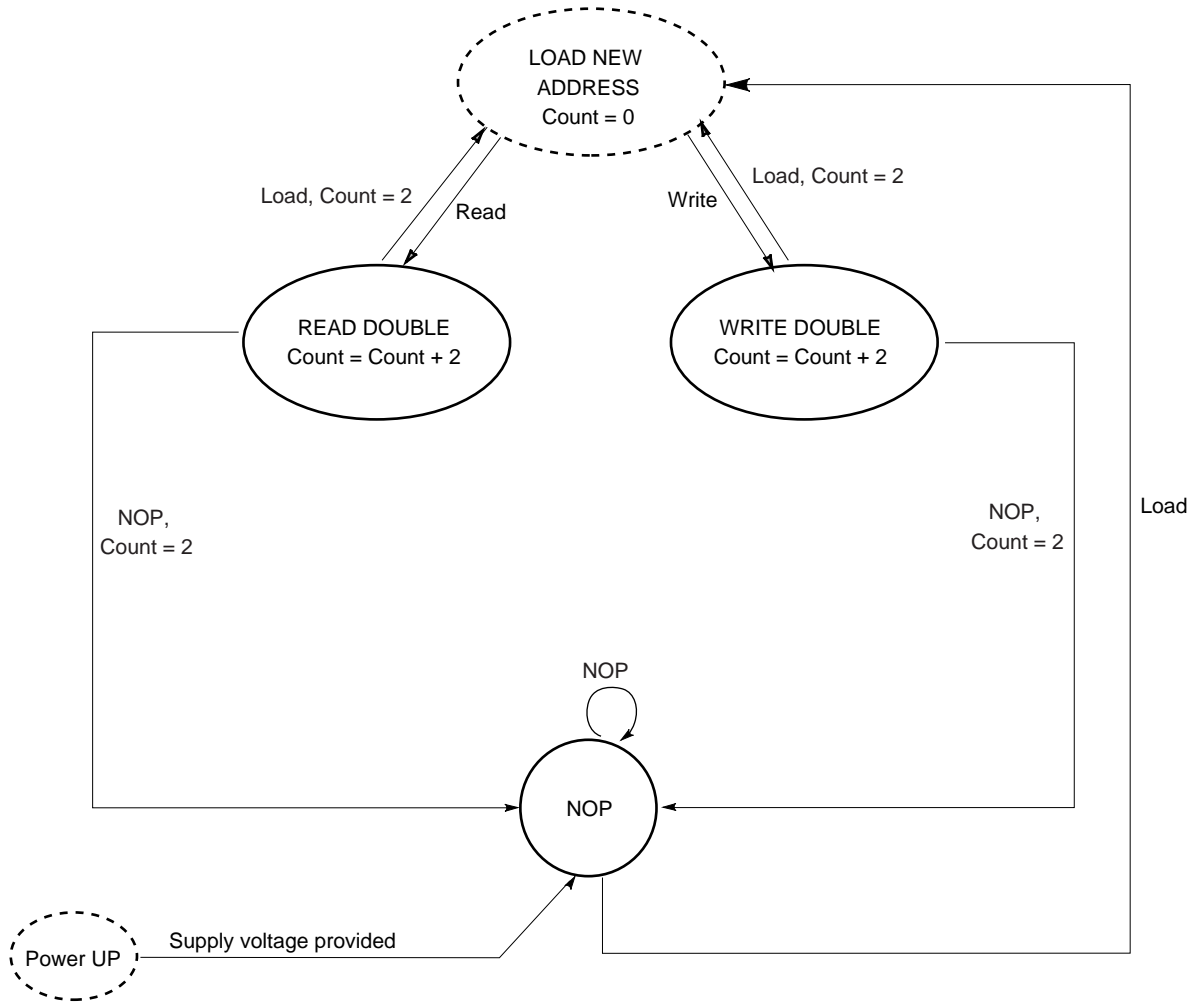

Remark State machine control timing sequence is controlled by K.

Electrical Specifications

Absolute Maximum Ratings

Parameter	Symbol	Conditions	MIN.	TYP.	MAX.	Unit
Supply voltage	V _{DD}		-0.5		+2.5	V
Output supply voltage	V _{DDQ}		-0.5		V _{DD}	V
Input voltage	V _{IN}		-0.5		V _{DD} + 0.5 (2.5 V MAX.)	V
Input / Output voltage	V _{I/O}		-0.5		V _{DDQ} + 0.5 (2.5 V MAX.)	V
Operating ambient temperature	T _A	Commercial	0		+70	°C
		Industrial	-40		+85	
Storage temperature	T _{stg}		-55		+125	°C

Caution Exposing the device to stress above those listed in Absolute Maximum Ratings could cause permanent damage. The device is not meant to be operated under conditions outside the limits described in the operational section of this specification. Exposure to Absolute Maximum Rating conditions for extended periods may affect device reliability.

Recommended DC Operating Conditions

Parameter	Symbol	Conditions	MIN.	TYP.	MAX.	Unit	Note
Supply voltage	V _{DD}		1.7		1.9	V	
Output supply voltage	V _{DDQ}		1.4		V _{DD}	V	1
Input HIGH voltage	V _{IH} (DC)		V _{REF} + 0.1		V _{DDQ} + 0.3	V	1, 2
Input LOW voltage	V _{IL} (DC)		-0.3		V _{REF} - 0.1	V	1, 2
Clock input voltage	V _{IN}		-0.3		V _{DDQ} + 0.3	V	1, 2
Reference voltage	V _{REF}		0.68		0.95	V	

- Notes**
1. During normal operation, V_{DDQ} must not exceed V_{DD}.
 2. Power-up: V_{IH} ≤ V_{DDQ} + 0.3 V and V_{DD} ≤ 1.7 V and V_{DDQ} ≤ 1.4 V for t ≤ 200 ms

Recommended AC Operating Conditions

Parameter	Symbol	Conditions	MIN.	TYP.	MAX.	Unit	Note
Input HIGH voltage	V _{IH} (AC)		V _{REF} + 0.2		-	V	1
Input LOW voltage	V _{IL} (AC)		-		V _{REF} - 0.2	V	1

- Note**
1. Overshoot: V_{IH} (AC) ≤ V_{DD} + 0.7 V (2.5 V MAX.) for t ≤ TKHKH/2
 Undershoot: V_{IL} (AC) ≥ -0.5 V for t ≤ TKHKH/2
 Control input signals may not have pulse widths less than TKHKL (MIN.) or operate at cycle rates less than TKHKH (MIN.).

DC Characteristics (V_{DD} = 1.8 ± 0.1 V)

Parameter	Symbol	Test condition		MIN.	TYP.	MAX.			Unit	Note
						x8, x9	x18	x36		
Input leakage current	I _{LI}			-2	-	+2			μA	
I/O leakage current	I _{LO}			-2	-	+2			μA	
Operating supply current (Read cycle / Write cycle)	I _{DD}	Note1	Commercial (T _A = 0 to +70°C)	-E37		690	970	1,090	mA	
				-E40		650	900	1,000		
				-E50		550	750	850		
			Industrial (T _A = -40 to +85°C)	-E40Y		750	1,030	-		
				-E50Y		630	860	-		
Standby supply current (NOP)	I _{SB1}	Note1	Commercial (T _A = 0 to +70°C)	-E37		520	520	520	mA	
				-E40		500	500	500		
				-E50		400	400	400		
			Industrial (T _A = -40 to +85°C)	-E40Y		550	550	-		
				-E50Y		450	450	-		
Output HIGH voltage	V _{OH(Low)}	I _{OH} ≤ 0.1 mA		V _{DDQ} - 0.2	-	V _{DDQ}			V	4, 5
	V _{OH}	Note2		V _{DDQ} /2 - 0.12	-	V _{DDQ} /2 + 0.12			V	4, 5
Output LOW voltage	V _{OL(Low)}	I _{OL} ≤ 0.1 mA		V _{SS}	-	0.2			V	4, 5
	V _{OL}	Note3		V _{DDQ} /2 - 0.12	-	V _{DDQ} /2 + 0.12			V	4, 5

- Notes**
1. V_{IN} ≤ V_{IL} or V_{IN} ≥ V_{IH}, I_{I/O} = 0 mA, Cycle = MAX.
 2. Outputs are impedance-controlled. |I_{OH}| = (V_{DDQ}/2)/(R_Q/5) ±15 % for values of 175 Ω ≤ R_Q ≤ 350 Ω.
 3. Outputs are impedance-controlled. I_{OL} = (V_{DDQ}/2)/(R_Q/5) ±15 for values of 175 Ω ≤ R_Q ≤ 350 Ω.
 4. AC load current is higher than the shown DC values.
 5. HSTL outputs meet JEDEC HSTL Class I standards.

Capacitance (T_A = 25°C, f = 1 MHz)

Parameter	Symbol	Test conditions	MIN.	TYP.	MAX.	Unit
Input capacitance (Address, Control)	C _{IN}	V _{IN} = 0 V		4	5	pF
Input / Output capacitance (D, Q, CQ, CQ#)	C _{I/O}	V _{I/O} = 0 V		6	7	pF
Clock Input capacitance	C _{clk}	V _{clk} = 0 V		5	6	pF

Remark These parameters are periodically sampled and not 100% tested.

Thermal Resistance

Parameter	Symbol	Test conditions	MIN.	TYP.	MAX.	Unit
Thermal resistance (junction – ambient)	θ _{j-a}			22.6		°C/W
Thermal resistance (junction – case)	θ _{j-c}			2.0		°C/W

Remark These parameters are simulated under the condition of air flow velocity = 1 m/s.

AC Characteristics ($V_{DD} = 1.8 \pm 0.1 \text{ V}$)

AC Test Conditions ($V_{DD} = 1.8 \pm 0.1 \text{ V}$, $V_{DDQ} = 1.4 \text{ V to } V_{DD}$)

Input waveform (Rise / Fall time $\leq 0.3 \text{ ns}$)

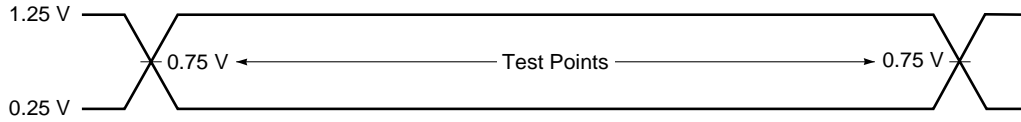

Output waveform

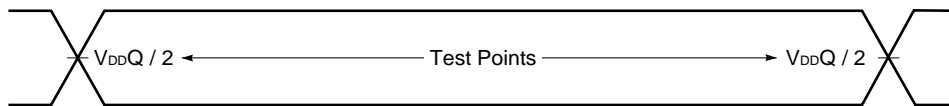

Output load condition

Figure 1. External load at test

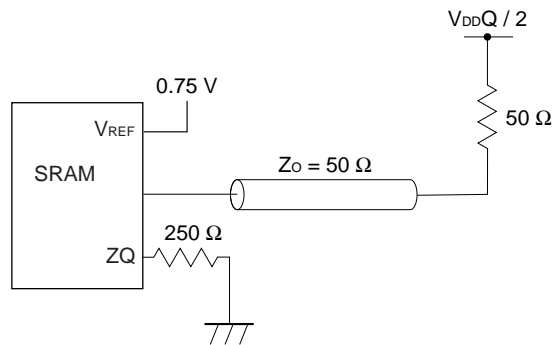

Read and Write Cycle

Parameter	Symbol	-E37 (270 MHz)		-E40, -E40Y (250 MHz)		-E50, -E50Y (200 MHz)		Unit	Note	
		MIN.	MAX.	MIN.	MAX.	MIN.	MAX.			
Clock										
Average Clock cycle time (K, K#, C, C#)	TKHKH	3.7	8.4	4.0	8.4	5.0	8.4	ns	1	
Clock phase jitter (K, K#, C, C#)	TKC var	–	0.2	–	0.2	–	0.2	ns	2	
Clock HIGH time (K, K#, C, C#)	TKHKL	1.5	–	1.6	–	2.0	–	ns		
Clock LOW time (K, K#, C, C#)	TKLKH	1.5	–	1.6	–	2.0	–	ns		
Clock HIGH to Clock# HIGH (K → K#, C → C#)	TKHK#H	1.7	–	1.8	–	2.2	–	ns		
Clock# HIGH to Clock HIGH (K# → K, C# → C)	TK#HKH	1.7	–	1.8	–	2.2	–	ns		
Clock to data clock (K → C, K# → C#)	TKHCH	250 to 270 MHz	0	1.65	–	–	–	–	ns	
		200 to 250 MHz	0	1.8	0	1.8	–	–		
		167 to 200 MHz	0	2.3	0	2.3	0	2.3		
		133 to 167 MHz	0	2.8	0	2.8	0	2.8		
		< 133 MHz	0	3.55	0	3.55	0	3.55		
DLL/PLL lock time (K, C)	TKC lock	1,024	–	1,024	–	1,024	–	Cycle	3	
K static to DLL/PLL reset	TKC reset	30	–	30	–	30	–	ns	4	
Output Times										
C, C# HIGH to output valid	TCHQV	–	0.45	–	0.45	–	0.45	ns		
C, C# HIGH to output hold	TCHQX	– 0.45	–	– 0.45	–	– 0.45	–	ns		
C, C# HIGH to echo clock valid	TCHCQV	–	0.45	–	0.45	–	0.45	ns		
C, C# HIGH to echo clock hold	TCHCQX	– 0.45	–	– 0.45	–	– 0.45	–	ns		
CQ, CQ# HIGH to output valid	TCQHQV	–	0.3	–	0.3	–	0.35	ns	5	
CQ, CQ# HIGH to output hold	TCQHQX	– 0.3	–	– 0.3	–	– 0.35	–	ns	5	
C HIGH to output High-Z	TCHQZ	–	0.45	–	0.45	–	0.45	ns		
C HIGH to output Low-Z	TCHQX1	– 0.45	–	– 0.45	–	– 0.45	–	ns		
Setup Times										
Address valid to K rising edge	TAVKH	0.5	–	0.5	–	0.6	–	ns	6	
Synchronous load input (LD#), read write input (R, W#) valid to K rising edge	TIVKH	0.5	–	0.5	–	0.6	–	ns	6	
Data inputs and write data select inputs (BWx#, NWx#) valid to K, K# rising edge	TDVKH	0.35	–	0.35	–	0.4	–	ns	6	
Hold Times										
K rising edge to address hold	TKHAX	0.5	–	0.5	–	0.6	–	ns	6	
K rising edge to synchronous load input (LD#), read write input (R, W#) hold	TKHIX	0.5	–	0.5	–	0.6	–	ns	6	
K, K# rising edge to data inputs and write data select inputs (BWx#, NWx#) hold	TKHDX	0.35	–	0.35	–	0.4	–	ns	6	

- Notes**
1. When debugging the system or board, these products can operate at a clock frequency slower than TKHKH (MAX.) without the DLL/PLL circuit being used, if DLL# = LOW. Read latency (RL) is changed to 1.5 clock in this operation. The AC/DC characteristics cannot be guaranteed, however.
 2. Clock phase jitter is the variance from clock rising edge to the next expected clock rising edge. TKC var (MAX.) indicates a peak-to-peak value.
 3. V_{DD} slew rate must be less than 0.1 V DC per 50 ns for DLL/PLL lock retention. DLL/PLL lock time begins once V_{DD} and input clock are stable. It is recommended that the device is kept NOP (LD# = HIGH) during these cycles.
 4. K input is monitored for this operation. See below for the timing.

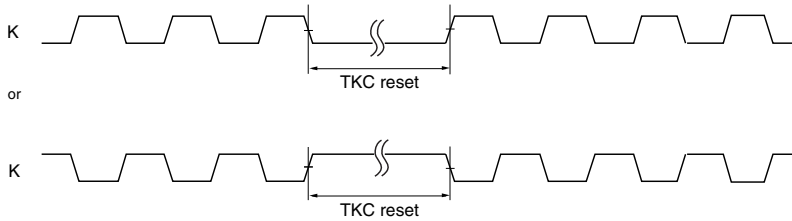

5. Echo clock is very tightly controlled to data valid / data hold. By design, there is a ± 0.1 ns variation from echo clock to data. The data sheet parameters reflect tester guardbands and test setup variations.
6. This is a synchronous device. All addresses, data and control lines must meet the specified setup and hold times for all latching clock edges.

- Remarks**
1. This parameter is sampled.
 2. Test conditions as specified with the output loading as shown in AC Test Conditions unless otherwise noted.
 3. Control input signals may not be operated with pulse widths less than TKHKL (MIN.).
 4. If C, C# are tied HIGH, K, K# become the references for C, C# timing parameters.
 5. V_{DDQ} is 1.5 V DC.

Read and Write Timing

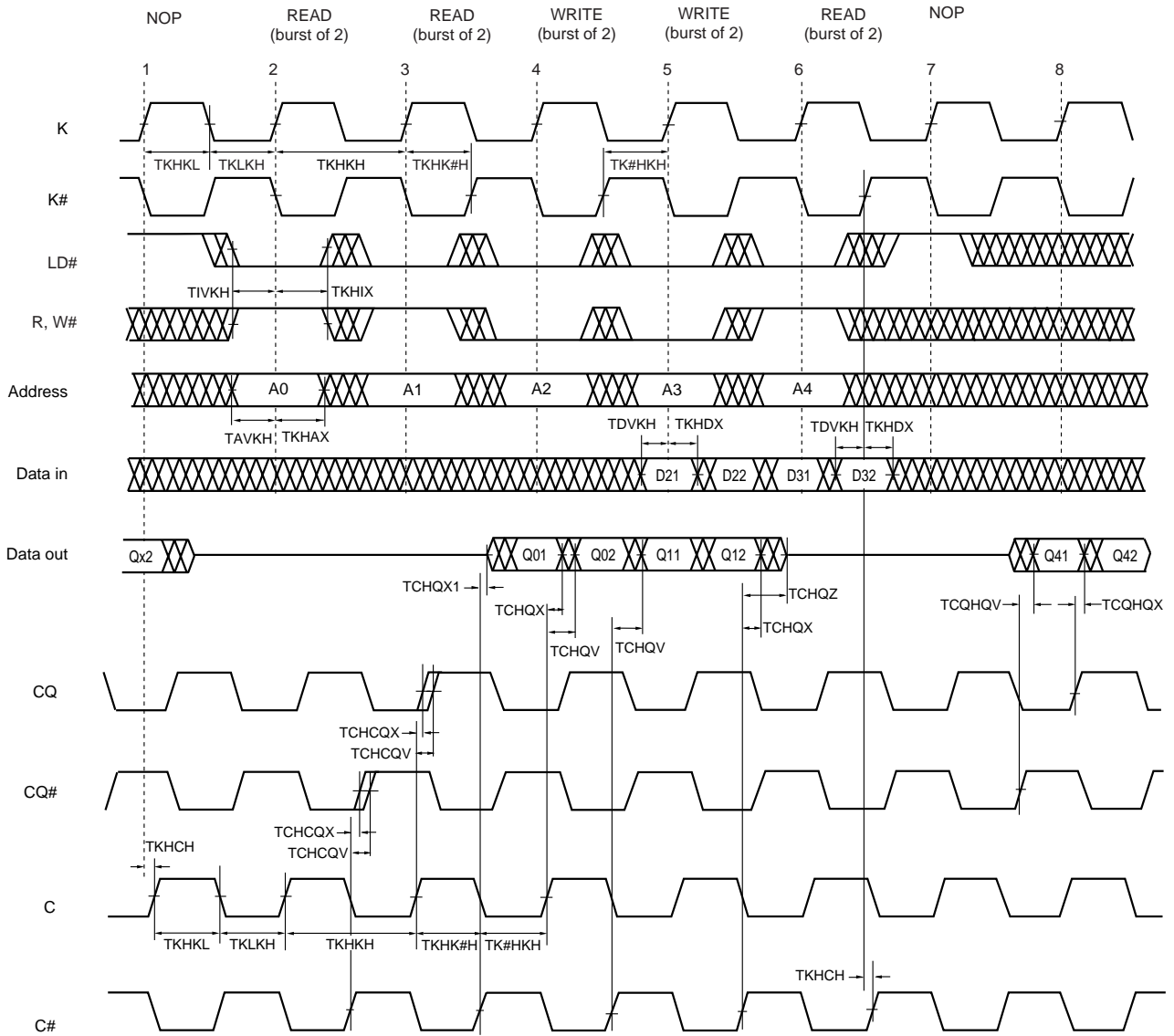

- Remarks**
1. Q01 refers to output from address A0+0.
Q02 refers to output from the next internal burst address following A0, i.e., A0+1.
 2. Outputs are disabled (high impedance) 2.5 clocks after the last READ (LD# = LOW, R, W# = HIGH) is input in the sequences of [READ]-[NOP] and [READ]-[WRITE].
 3. In this example, if address A4=A3, data Q41=D31 and Q42=D32.
Write data is forwarded immediately as read results.

Application Example

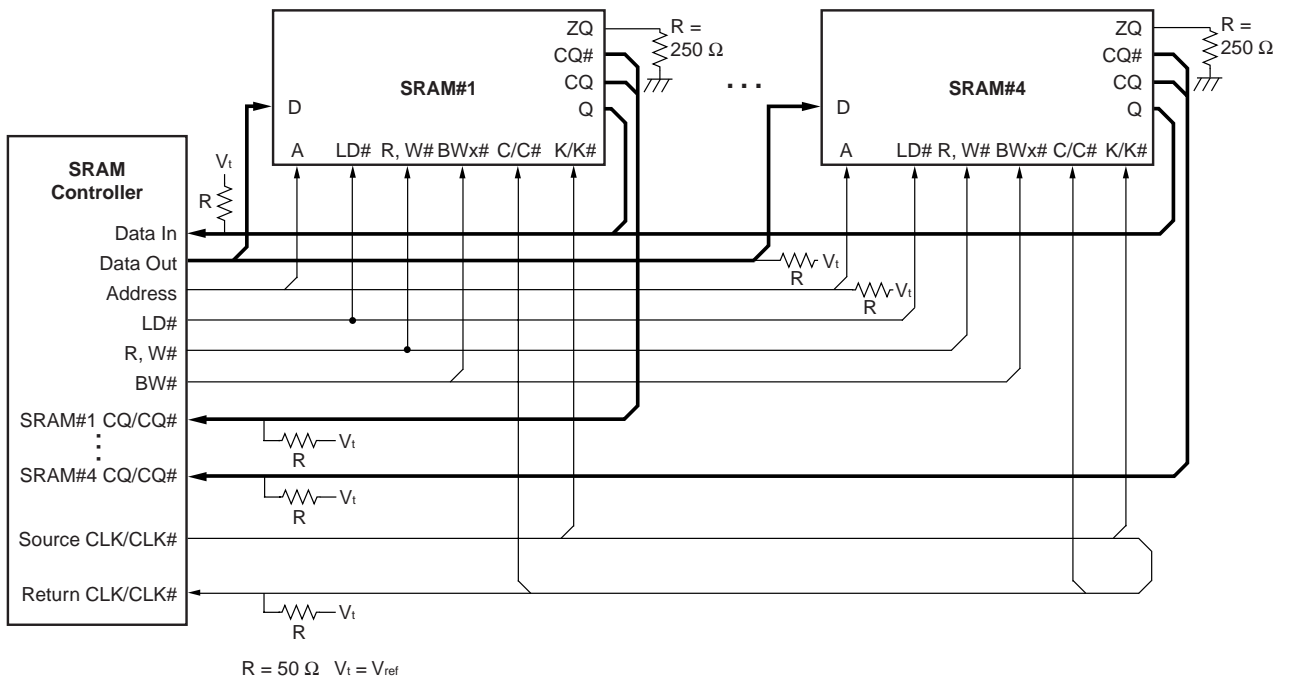

Remark AC specifications are defined at the condition of SRAM outputs, CQ, CQ# and Q with termination.

JTAG Specification

These products support a limited set of JTAG functions as in IEEE standard 1149.1.

Test Access Port (TAP) Pins

Pin name	Pin assignments	Description
TCK	2R	Test Clock Input. All input are captured on the rising edge of TCK and all outputs propagate from the falling edge of TCK.
TMS	10R	Test Mode Select. This is the command input for the TAP controller state machine.
TDI	11R	Test Data Input. This is the input side of the serial registers placed between TDI and TDO. The register placed between TDI and TDO is determined by the state of the TAP controller state machine and the instruction that is currently loaded in the TAP instruction.
TDO	1R	Test Data Output. This is the output side of the serial registers placed between TDI and TDO. Output changes in response to the falling edge of TCK.

Remark The device does not have TRST (TAP reset). The Test-Logic Reset state is entered while TMS is held HIGH for five rising edges of TCK. The TAP controller state is also reset on the SRAM POWER-UP.

JTAG DC Characteristics (V_{DD} = 1.8 ± 0.1 V, unless otherwise noted)

Parameter	Symbol	Conditions	MIN.	TYP.	MAX.	Unit
JTAG Input leakage current	I _{LI}	0 V ≤ V _{IN} ≤ V _{DD}	-5.0	-	+5.0	μA
JTAG I/O leakage current	I _{LO}	0 V ≤ V _{IN} ≤ V _{DDQ} , Outputs disabled	-5.0	-	+5.0	μA
JTAG input HIGH voltage	V _{IH}		1.3	-	V _{DD} +0.3	V
JTAG input LOW voltage	V _{IL}		-0.3	-	+0.5	V
JTAG output HIGH voltage	V _{OH1}	I _{OH} C = 100 μA	1.6	-	-	V
	V _{OH2}	I _{OH} T = 2 mA	1.4	-	-	V
JTAG output LOW voltage	V _{OL1}	I _{OL} C = 100 μA	-	-	0.2	V
	V _{OL2}	I _{OL} T = 2 mA	-	-	0.4	V

JTAG AC Test Conditions

Input waveform (Rise / Fall time ≤ 1 ns)

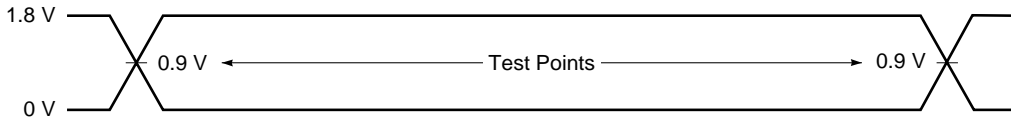

Output waveform

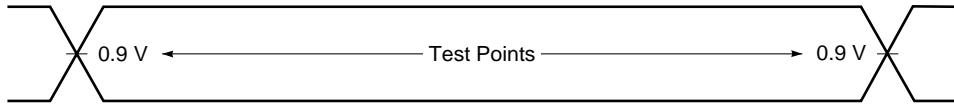

Output load

Figure 2. External load at test

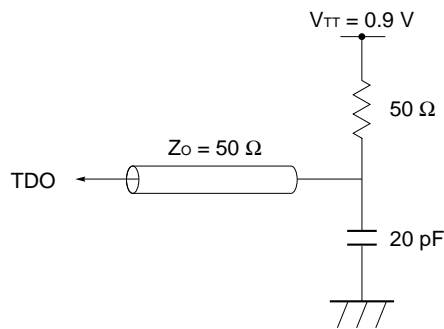

JTAG AC Characteristics

Parameter	Symbol	Conditions	MIN.	TYP.	MAX.	Unit
Clock						
Clock cycle time	$t_{H\overline{TH}}$		50	–	–	ns
Clock frequency	f_{TF}		–	–	20	MHz
Clock HIGH time	$t_{H\overline{TL}}$		20	–	–	ns
Clock LOW time	$t_{\overline{L}H}$		20	–	–	ns
Output time						
TCK LOW to TDO unknown	t_{TLOX}		0	–	–	ns
TCK LOW to TDO valid	t_{TLOV}		–	–	10	ns
Setup time						
TMS setup time	$t_{MV\overline{TH}}$		5	–	–	ns
TDI valid to TCK HIGH	$t_{DV\overline{TH}}$		5	–	–	ns
Capture setup time	t_{CS}		5	–	–	ns
Hold time						
TMS hold time	$t_{HM\overline{X}}$		5	–	–	ns
TCK HIGH to TDI invalid	$t_{HD\overline{X}}$		5	–	–	ns
Capture hold time	t_{CH}		5	–	–	ns

JTAG Timing Diagram

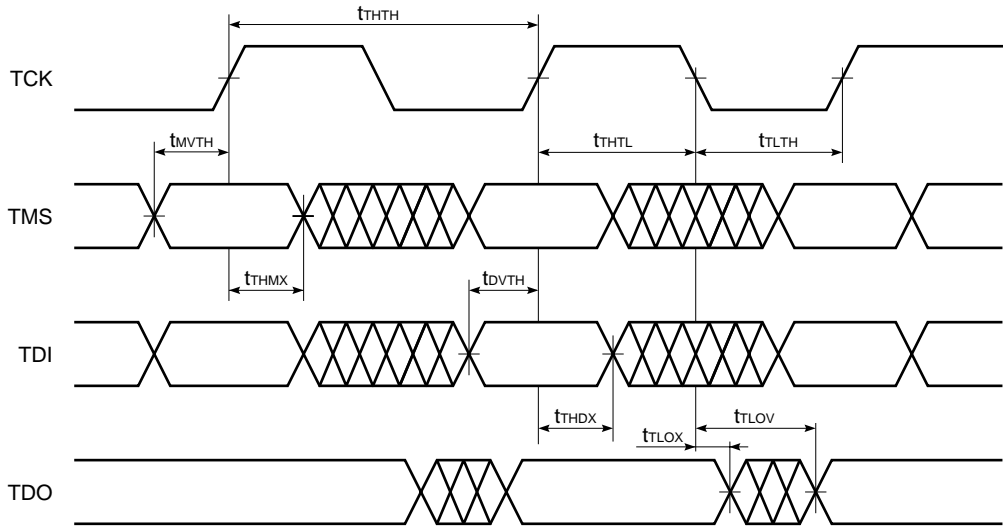

Scan Register Definition (1)

Register name	Description
Instruction register	The instruction register holds the instructions that are executed by the TAP controller when it is moved into the run-test/idle or the various data register state. The register can be loaded when it is placed between the TDI and TDO pins. The instruction register is automatically preloaded with the IDCODE instruction at power-up whenever the controller is placed in test-logic-reset state.
Bypass register	The bypass register is a single bit register that can be placed between TDI and TDO. It allows serial test data to be passed through the RAMs TAP to another device in the scan chain with as little delay as possible.
ID register	The ID Register is a 32 bit register that is loaded with a device and vendor specific 32 bit code when the controller is put in capture-DR state with the IDCODE command loaded in the instruction register. The register is then placed between the TDI and TDO pins when the controller is moved into shift-DR state.
Boundary register	The boundary register, under the control of the TAP controller, is loaded with the contents of the RAMs I/O ring when the controller is in capture-DR state and then is placed between the TDI and TDO pins when the controller is moved to shift-DR state. Several TAP instructions can be used to activate the boundary register. The Scan Exit Order tables describe which device bump connects to each boundary register location. The first column defines the bit's position in the boundary register. The second column is the name of the input or I/O at the bump and the third column is the bump number.

Scan Register Definition (2)

Register name	Bit size	Unit
Instruction register	3	bit
Bypass register	1	bit
ID register	32	bit
Boundary register	109	bit

ID Register Definition

Part number	Organization	ID [31:28] vendor revision no.	ID [27:12] part no.	ID [11:1] vendor ID no.	ID [0] fix bit
μPD44324085-A	4M x 8	XXXX	0000 0000 0100 0101	00000010000	1
μPD44324095-A	4M x 9	XXXX	0000 0000 0100 0110	00000010000	1
μPD44324185-A	2M x 18	XXXX	0000 0000 0100 0111	00000010000	1
μPD44324365-A	1M x 36	XXXX	0000 0000 0100 1000	00000010000	1

SCAN Exit Order

Bit no.	Signal name				Bump ID
	x8	x9	x18	x36	
1	C#				6R
2	C				6P
3	A				6N
4	A				7P
5	A				7N
6	A				7R
7	A				8R
8	A				8P
9	A				9R
10	NC	Q0	Q0	Q0	11P
11	NC	D0	D0	D0	10P
12	NC	NC	NC	D9	10N
13	NC	NC	NC	Q9	9P
14	NC	NC	Q1	Q1	10M
15	NC	NC	D1	D1	11N
16	NC	NC	NC	D10	9M
17	NC	NC	NC	Q10	9N
18	Q0	Q1	Q2	Q2	11L
19	D0	D1	D2	D2	11M
20	NC	NC	NC	D11	9L
21	NC	NC	NC	Q11	10L
22	NC	NC	Q3	Q3	11K
23	NC	NC	D3	D3	10K
24	NC	NC	NC	D12	9J
25	NC	NC	NC	Q12	9K
26	Q1	Q2	Q4	Q4	10J
27	D1	D2	D4	D4	11J
28	ZQ				11H
29	NC	NC	NC	D13	10G
30	NC	NC	NC	Q13	9G
31	NC	NC	Q5	Q5	11F
32	NC	NC	D5	D5	11G
33	NC	NC	NC	D14	9F
34	NC	NC	NC	Q14	10F
35	Q2	Q3	Q6	Q6	11E
36	D2	D3	D6	D6	10E

Bit no.	Signal name				Bump ID
	x8	X9	x18	x36	
37	NC	NC	NC	D15	10D
38	NC	NC	NC	Q15	9E
39	NC	NC	Q7	Q7	10C
40	NC	NC	D7	D7	11D
41	NC	NC	NC	D16	9C
42	NC	NC	NC	Q16	9D
43	Q3	Q4	Q8	Q8	11B
44	D3	D4	D8	D8	11C
45	NC	NC	NC	D17	9B
46	NC	NC	NC	Q17	10B
47	CQ				11A
48	A	A	V _{SS}	V _{SS}	10A
49	A				9A
50	A				8B
51	A				7C
52	A				6C
53	LD#				8A
54	NC	NC	NC	BW1#	7A
55	NW0#	BW0#	BW0#	BW0#	7B
56	K				6B
57	K#				6A
58	NC	NC	NC	BW3#	5B
59	NW1#	NC	BW1#	BW2#	5A
60	R, W#				4A
61	A				5C
62	A				4B
63	A	A	A	NC	3A
64	V _{SS}				2A
65	CQ#				1A
66	NC	NC	Q9	Q18	2B
67	NC	NC	D9	D18	3B
68	NC	NC	NC	D27	1C
69	NC	NC	NC	Q27	1B
70	NC	NC	Q10	Q19	3D
71	NC	NC	D10	D19	3C
72	NC	NC	NC	D28	1D

Bit no.	Signal name				Bump ID
	x8	X9	x18	x36	
73	NC	NC	NC	Q28	2C
74	Q4	Q5	Q11	Q20	3E
75	D4	D5	D11	D20	2D
76	NC	NC	NC	D29	2E
77	NC	NC	NC	Q29	1E
78	NC	NC	Q12	Q21	2F
79	NC	NC	D12	D21	3F
80	NC	NC	NC	D30	1G
81	NC	NC	NC	Q30	1F
82	Q5	Q6	Q13	Q22	3G
83	D5	D6	D13	D22	2G
84	DLL#				1H
85	NC	NC	NC	D31	1J
86	NC	NC	NC	Q31	2J
87	NC	NC	Q14	Q23	3K
88	NC	NC	D14	D23	3J
89	NC	NC	NC	D32	2K
90	NC	NC	NC	Q32	1K
91	Q6	Q7	Q15	Q24	2L
92	D6	D7	D15	D24	3L
93	NC	NC	NC	D33	1M
94	NC	NC	NC	Q33	1L
95	NC	NC	Q16	Q25	3N
96	NC	NC	D16	D25	3M
97	NC	NC	NC	D34	1N
98	NC	NC	NC	Q34	2M
99	Q7	Q8	Q17	Q26	3P
100	D7	D8	D17	D26	2N
101	NC	NC	NC	D35	2P
102	NC	NC	NC	Q35	1P
103	A				3R
104	A				4R
105	A				4P
106	A				5P
107	A				5N
108	A				5R
109	-				Internal

Remark Bump ID 10A of bit no. 48 can also be used as NC if the product is x18 or x36.
 Bump ID 2A of bit no. 64 can also be used as NC.
 The register always indicates LOW, however.

JTAG Instructions

Instructions	Description
EXTEST	The EXTEST instruction allows circuitry external to the component package to be tested. Boundary-scan register cells at output pins are used to apply test vectors, while those at input pins capture test results. Typically, the first test vector to be applied using the EXTEST instruction will be shifted into the boundary scan register using the PRELOAD instruction. Thus, during the update-IR state of EXTEST, the output drive is turned on and the PRELOAD data is driven onto the output pins.
IDCODE	The IDCODE instruction causes the ID ROM to be loaded into the ID register when the controller is in capture-DR mode and places the ID register between the TDI and TDO pins in shift-DR mode. The IDCODE instruction is the default instruction loaded in at power up and any time the controller is placed in the test-logic-reset state.
BYPASS	When the BYPASS instruction is loaded in the instruction register, the bypass register is placed between TDI and TDO. This occurs when the TAP controller is moved to the shift-DR state. This allows the board level scan path to be shortened to facilitate testing of other devices in the scan path.
SAMPLE / PRELOAD	SAMPLE / PRELOAD is a Standard 1149.1 mandatory public instruction. When the SAMPLE / PRELOAD instruction is loaded in the instruction register, moving the TAP controller into the capture-DR state loads the data in the RAMs input and Q pins into the boundary scan register. Because the RAM clock(s) are independent from the TAP clock (TCK) it is possible for the TAP to attempt to capture the I/O ring contents while the input buffers are in transition (i.e., in a metastable state). Although allowing the TAP to sample metastable input will not harm the device, repeatable results cannot be expected. RAM input signals must be stabilized for long enough to meet the TAPs input data capture setup plus hold time (t_{cs} plus t_{ch}). The RAMs clock inputs need not be paused for any other TAP operation except capturing the I/O ring contents into the boundary scan register. Moving the controller to shift-DR state then places the boundary scan register between the TDI and TDO pins.
SAMPLE-Z	If the SAMPLE-Z instruction is loaded in the instruction register, all RAM Q pins are forced to an inactive drive state (high impedance) and the boundary register is connected between TDI and TDO when the TAP controller is moved to the shift-DR state.

JTAG Instruction Coding

IR2	IR1	IR0	Instruction	Note
0	0	0	EXTEST	
0	0	1	IDCODE	
0	1	0	SAMPLE-Z	1
0	1	1	RESERVED	2
1	0	0	SAMPLE / PRELOAD	
1	0	1	RESERVED	2
1	1	0	RESERVED	2
1	1	1	BYPASS	

- Notes**
1. TRISTATE all Q pins and CAPTURE the pad values into a SERIAL SCAN LATCH.
 2. Do not use this instruction code because the vendor uses it to evaluate this product.

Output Pin States of CQ, CQ# and Q

Instructions	Control-Register Status	Output Pin Status	
		CQ,CQ#	Q
EXTEST	0	Update	High-Z
	1	Update	Update
IDCODE	0	SRAM	SRAM
	1	SRAM	SRAM
SAMPLE-Z	0	High-Z	High-Z
	1	High-Z	High-Z
SAMPLE	0	SRAM	SRAM
	1	SRAM	SRAM
BYPASS	0	SRAM	SRAM
	1	SRAM	SRAM

Remark The output pin statuses during each instruction vary according to the Control-Register status (value of Boundary Scan Register, bit no. 109). There are three statuses:

- Update : Contents of the "Update Register" are output to the output pin (QDR Pad).
- SRAM : Contents of the SRAM internal output "SRAM Output" are output to the output pin (QDR Pad).
- High-Z : The output pin (QDR Pad) becomes high impedance by controlling of the "High-Z JTAG ctrl".

The Control-Register status is set during Update-DR at the EXTEST or SAMPLE instruction.

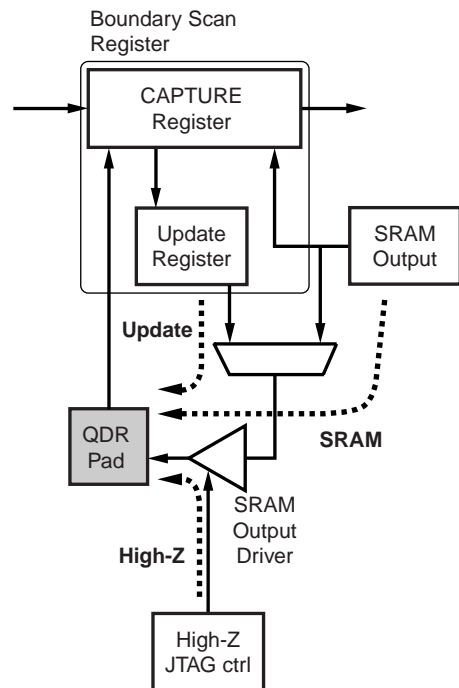

Boundary Scan Register Status of Output Pins CQ, CQ# and Q

Instructions	SRAM Status	Boundary Scan Register Status		Note
		CQ, CQ#	Q	
EXTEST	READ (Low-Z)	Pad	Pad	
	NOP (High-Z)	Pad	Pad	
IDCODE	READ (Low-Z)	-	-	No definition
	NOP (High-Z)	-	-	
SAMPLE-Z	READ (Low-Z)	Pad	Pad	
	NOP (High-Z)	Pad	Pad	
SAMPLE	READ (Low-Z)	Internal	Internal	
	NOP (High-Z)	Internal	Pad	
BYPASS	READ (Low-Z)	-	-	No definition
	NOP (High-Z)	-	-	

Remark The Boundary Scan Register statuses during execution each instruction vary according to the instruction code and SRAM operation mode. There are two statuses:

- Pad : Contents of the output pin (QDR Pad) are captured in the "CAPTURE Register" in the Boundary Scan Register.
- Internal : Contents of the SRAM internal output "SRAM Output" are captured in the "CAPTURE Register" in the Boundary Scan Register.

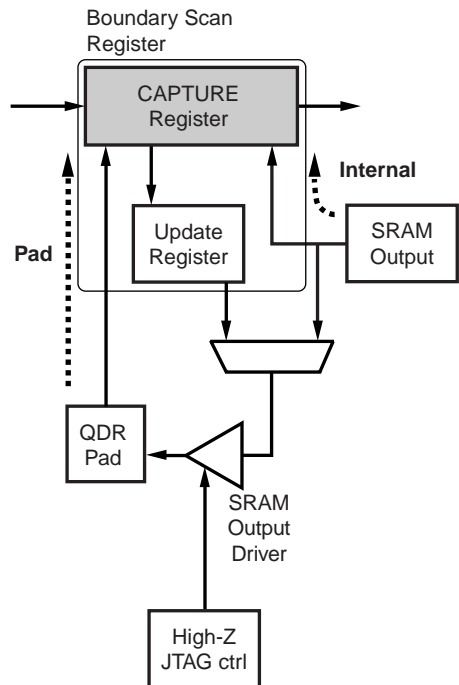

TAP Controller State Diagram

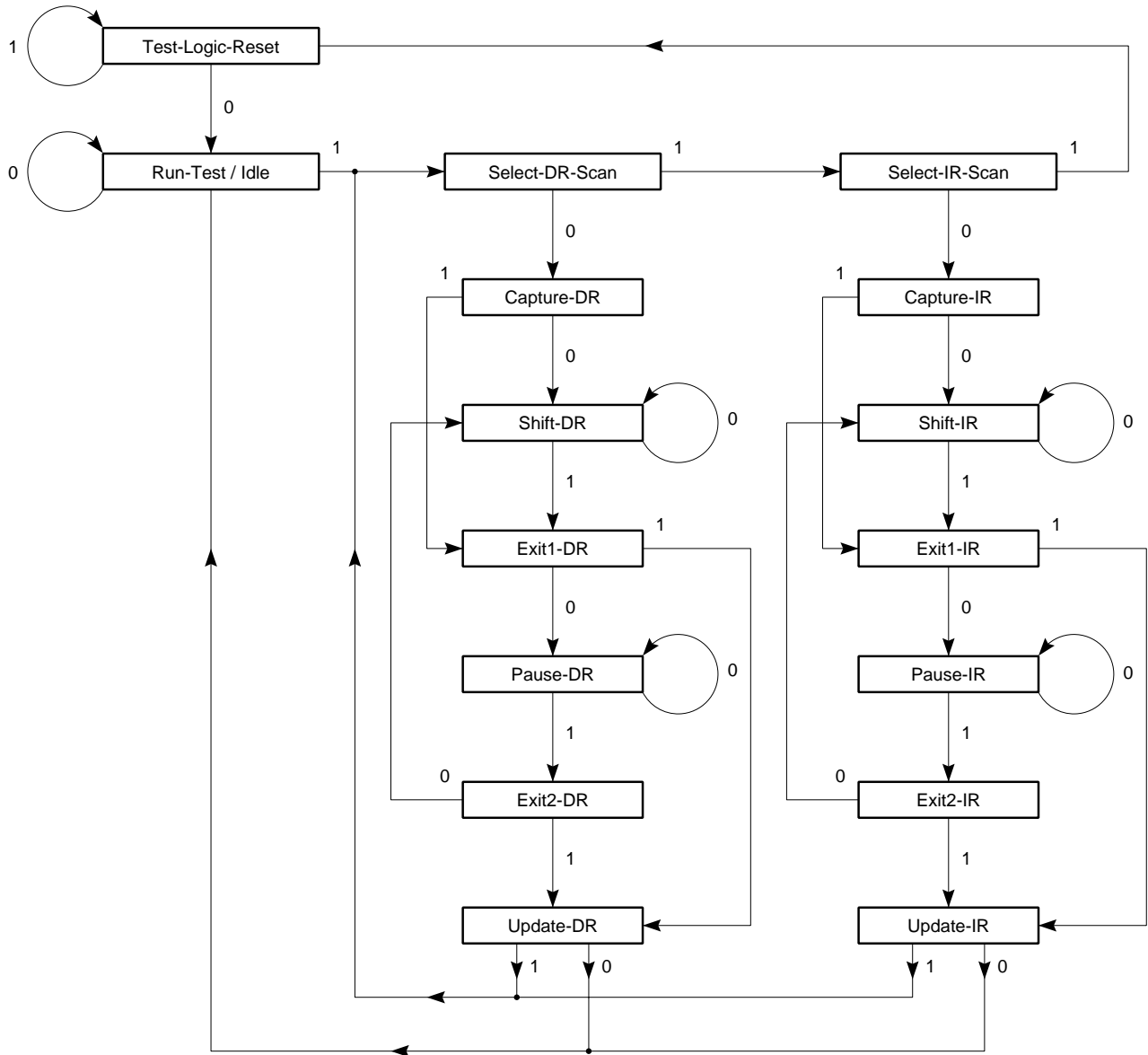

Disabling the Test Access Port

It is possible to use this device without utilizing the TAP. To disable the TAP Controller without interfering with normal operation of the device, TCK must be tied to V_{SS} to preclude mid level inputs. TDI and TMS may be left open but fix them to V_{DD} via a resistor of about 1 kΩ when the TAP controller is not used. TDO should be left unconnected also when the TAP controller is not used.

Test Logic Operation (Instruction Scan)

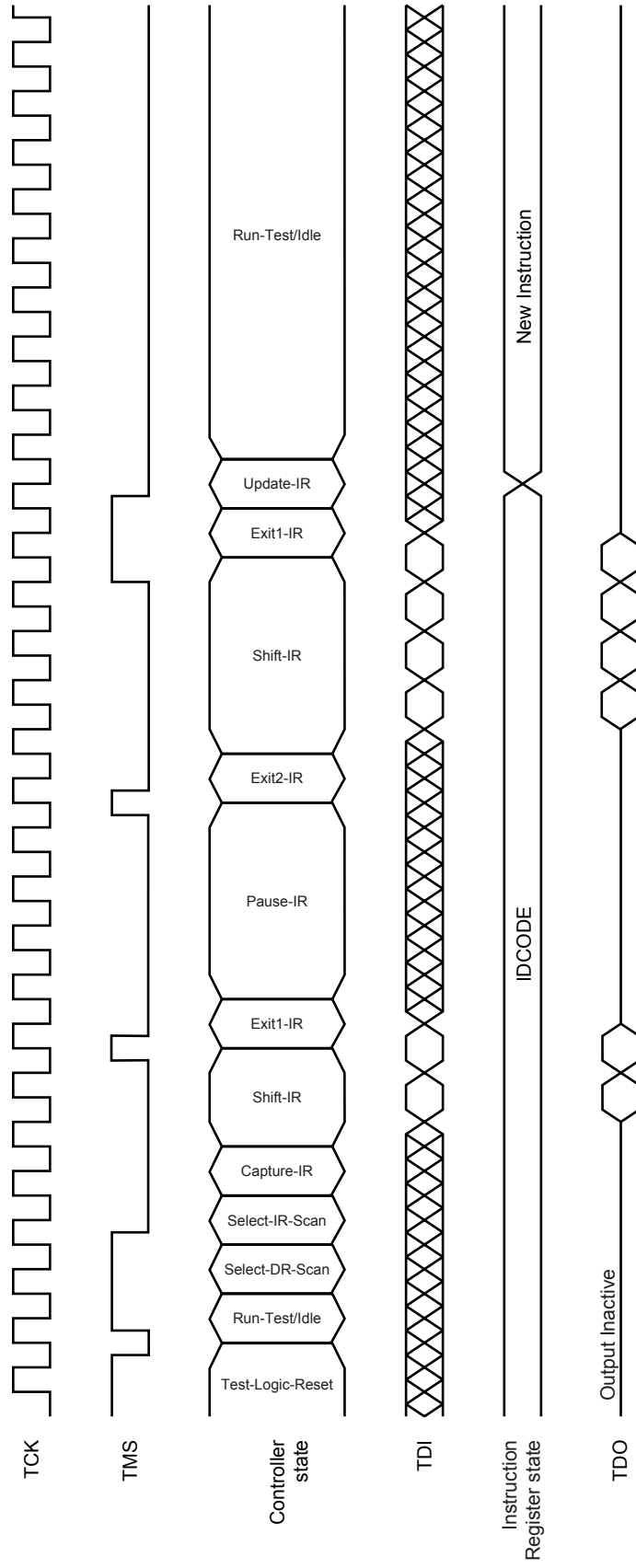

Test Logic (Data Scan)

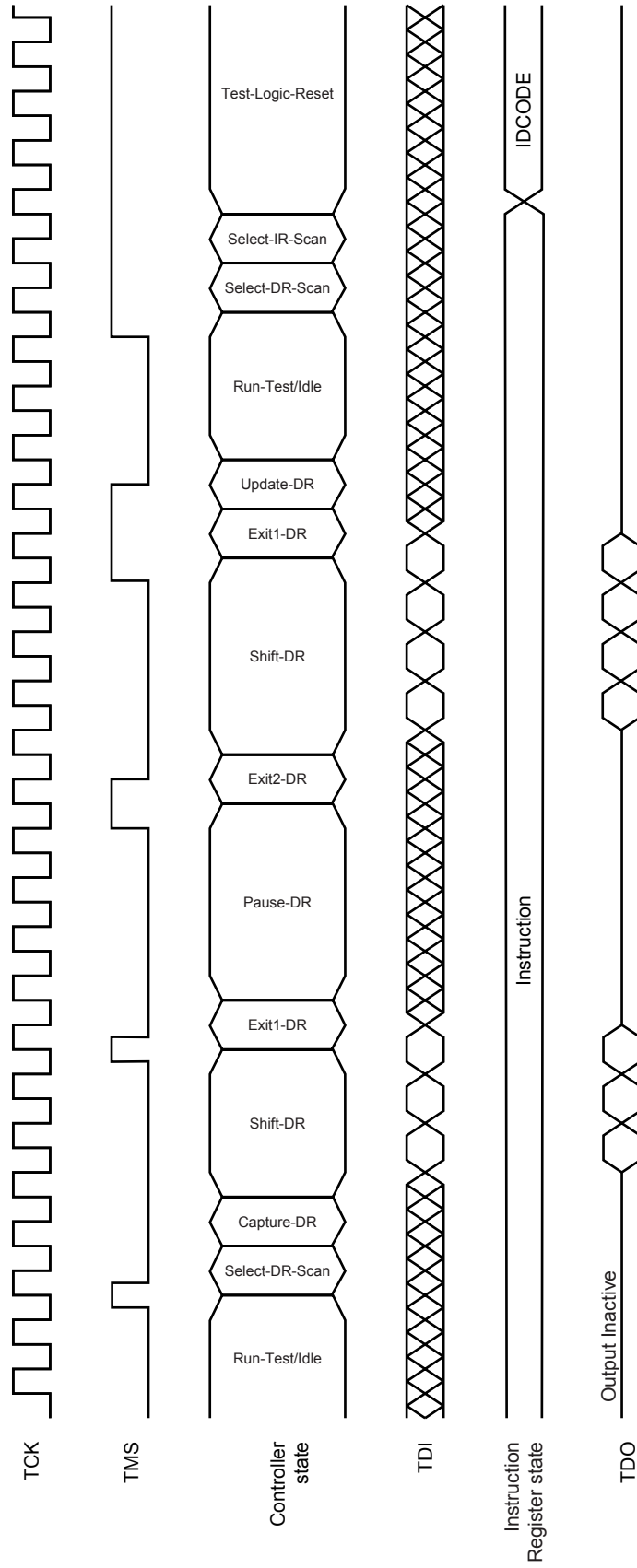

Package Drawing

165-PIN PLASTIC BGA (13x15)

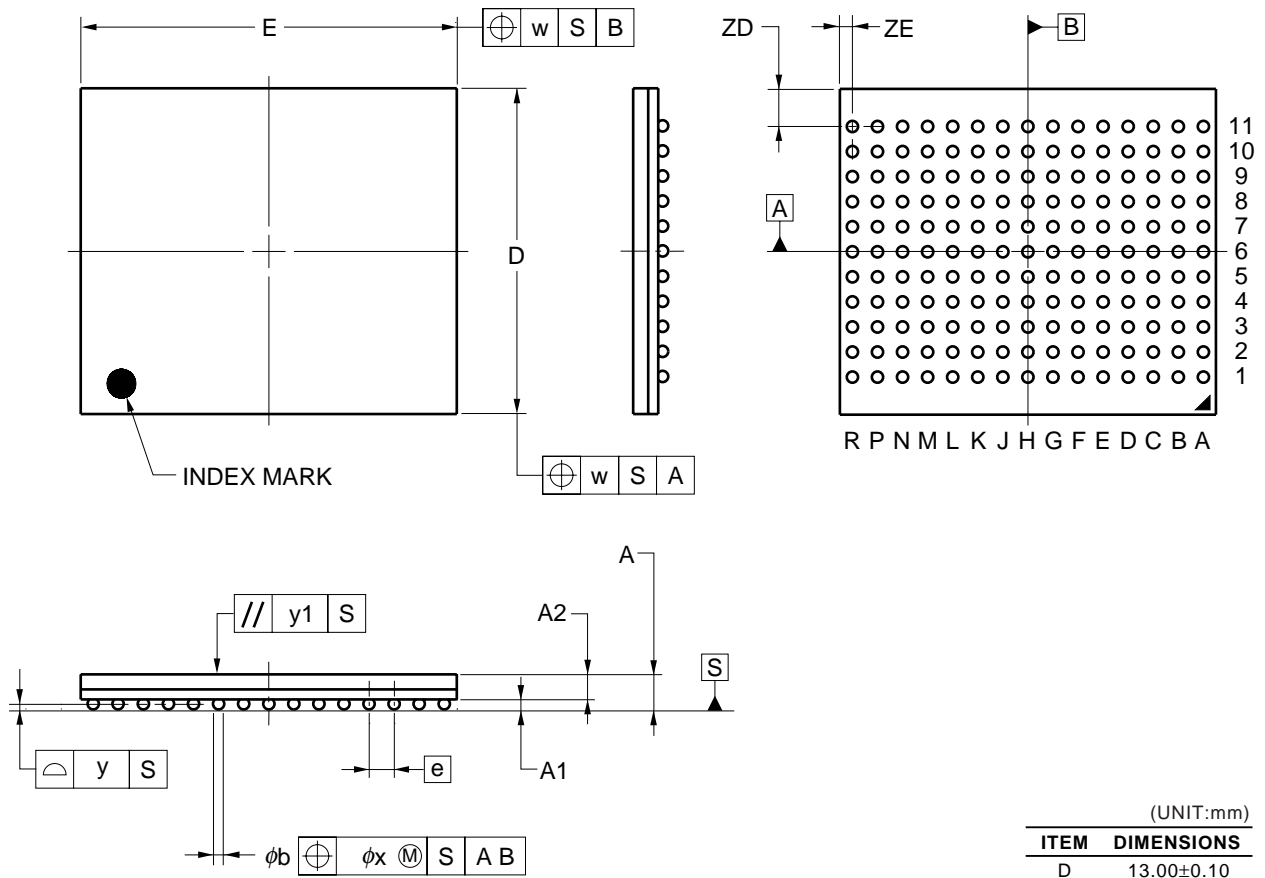

(UNIT:mm)

ITEM	DIMENSIONS
D	13.00±0.10
E	15.00±0.10
w	0.15
e	1.00
A	1.40±0.11
A1	0.40±0.05
A2	1.00
b	0.50±0.05
x	0.08
y	0.10
y1	0.20
ZD	1.50
ZE	0.50

P165F5-100-EQ2

Recommended Soldering Condition

Please consult with our sales offices for soldering conditions of these products.

Types of Surface Mount Devices

μ PD44324085F5-EQ2-A : 165-pin PLASTIC BGA (13 x 15)

μ PD44324095F5-EQ2-A : 165-pin PLASTIC BGA (13 x 15)

μ PD44324185F5-EQ2-A : 165-pin PLASTIC BGA (13 x 15)

μ PD44324365F5-EQ2-A : 165-pin PLASTIC BGA (13 x 15)

Quality Grade

- A quality grade of the products is "Standard".
- Anti-radioactive design is not implemented in the products.
- Semiconductor devices have the possibility of unexpected defects by affection of cosmic ray that reach to the ground and so forth.

[MEMO]

NOTES FOR CMOS DEVICES

① VOLTAGE APPLICATION WAVEFORM AT INPUT PIN

Waveform distortion due to input noise or a reflected wave may cause malfunction. If the input of the CMOS device stays in the area between V_{IL} (MAX) and V_{IH} (MIN) due to noise, etc., the device may malfunction. Take care to prevent chattering noise from entering the device when the input level is fixed, and also in the transition period when the input level passes through the area between V_{IL} (MAX) and V_{IH} (MIN).

② HANDLING OF UNUSED INPUT PINS

Unconnected CMOS device inputs can be cause of malfunction. If an input pin is unconnected, it is possible that an internal input level may be generated due to noise, etc., causing malfunction. CMOS devices behave differently than Bipolar or NMOS devices. Input levels of CMOS devices must be fixed high or low by using pull-up or pull-down circuitry. Each unused pin should be connected to V_{DD} or GND via a resistor if there is a possibility that it will be an output pin. All handling related to unused pins must be judged separately for each device and according to related specifications governing the device.

③ PRECAUTION AGAINST ESD

A strong electric field, when exposed to a MOS device, can cause destruction of the gate oxide and ultimately degrade the device operation. Steps must be taken to stop generation of static electricity as much as possible, and quickly dissipate it when it has occurred. Environmental control must be adequate. When it is dry, a humidifier should be used. It is recommended to avoid using insulators that easily build up static electricity. Semiconductor devices must be stored and transported in an anti-static container, static shielding bag or conductive material. All test and measurement tools including work benches and floors should be grounded. The operator should be grounded using a wrist strap. Semiconductor devices must not be touched with bare hands. Similar precautions need to be taken for PW boards with mounted semiconductor devices.

④ STATUS BEFORE INITIALIZATION

Power-on does not necessarily define the initial status of a MOS device. Immediately after the power source is turned ON, devices with reset functions have not yet been initialized. Hence, power-on does not guarantee output pin levels, I/O settings or contents of registers. A device is not initialized until the reset signal is received. A reset operation must be executed immediately after power-on for devices with reset functions.

⑤ POWER ON/OFF SEQUENCE

In the case of a device that uses different power supplies for the internal operation and external interface, as a rule, switch on the external power supply after switching on the internal power supply. When switching the power supply off, as a rule, switch off the external power supply and then the internal power supply. Use of the reverse power on/off sequences may result in the application of an overvoltage to the internal elements of the device, causing malfunction and degradation of internal elements due to the passage of an abnormal current.

The correct power on/off sequence must be judged separately for each device and according to related specifications governing the device.

⑥ INPUT OF SIGNAL DURING POWER OFF STATE

Do not input signals or an I/O pull-up power supply while the device is not powered. The current injection that results from input of such a signal or I/O pull-up power supply may cause malfunction and the abnormal current that passes in the device at this time may cause degradation of internal elements. Input of signals during the power off state must be judged separately for each device and according to related specifications governing the device.

- **The information in this document is current as of July, 2009. The information is subject to change without notice. For actual design-in, refer to the latest publications of NEC Electronics data sheets, etc., for the most up-to-date specifications of NEC Electronics products. Not all products and/or types are available in every country. Please check with an NEC Electronics sales representative for availability and additional information.**
- No part of this document may be copied or reproduced in any form or by any means without the prior written consent of NEC Electronics. NEC Electronics assumes no responsibility for any errors that may appear in this document.
- NEC Electronics does not assume any liability for infringement of patents, copyrights or other intellectual property rights of third parties by or arising from the use of NEC Electronics products listed in this document or any other liability arising from the use of such products. No license, express, implied or otherwise, is granted under any patents, copyrights or other intellectual property rights of NEC Electronics or others.
- Descriptions of circuits, software and other related information in this document are provided for illustrative purposes in semiconductor product operation and application examples. The incorporation of these circuits, software and information in the design of a customer's equipment shall be done under the full responsibility of the customer. NEC Electronics assumes no responsibility for any losses incurred by customers or third parties arising from the use of these circuits, software and information.
- While NEC Electronics endeavors to enhance the quality and safety of NEC Electronics products, customers agree and acknowledge that the possibility of defects thereof cannot be eliminated entirely. In addition, NEC Electronics products are not taken measures to prevent radioactive rays in the product design. When customers use NEC Electronics products with their products, customers shall, on their own responsibility, incorporate sufficient safety measures such as redundancy, fire-containment and anti-failure features to their products in order to avoid risks of the damages to property (including public or social property) or injury (including death) to persons, as the result of defects of NEC Electronics products.
- NEC Electronics products are classified into the following three quality grades: "Standard", "Special" and "Specific".

The "Specific" quality grade applies only to NEC Electronics products developed based on a customer-designated "quality assurance program" for a specific application. The recommended applications of an NEC Electronics product depend on its quality grade, as indicated below. Customers must check the quality grade of each NEC Electronics product before using it in a particular application.

"Standard": Computers, office equipment, communications equipment, test and measurement equipment, audio and visual equipment, home electronic appliances, machine tools, personal electronic equipment and industrial robots.

"Special": Transportation equipment (automobiles, trains, ships, etc.), traffic control systems, anti-disaster systems, anti-crime systems, safety equipment and medical equipment (not specifically designed for life support).

"Specific": Aircraft, aerospace equipment, submersible repeaters, nuclear reactor control systems, life support systems and medical equipment for life support, etc.

The quality grade of NEC Electronics products is "Standard" unless otherwise expressly specified in NEC Electronics data sheets or data books, etc. If customers wish to use NEC Electronics products in applications not intended by NEC Electronics, they must contact an NEC Electronics sales representative in advance to determine NEC Electronics' willingness to support a given application.

(Note)

- (1) "NEC Electronics" as used in this statement means NEC Electronics Corporation and also includes its majority-owned subsidiaries.
- (2) "NEC Electronics products" means any product developed or manufactured by or for NEC Electronics (as defined above).