



The Infinite Bandwidth Company™

MIC5016/5017

Low-Cost Dual High- or Low-Side MOSFET Driver

Final Information

General Description

MIC5016 and MIC5017 dual MOSFET drivers are designed for gate control of N-channel, enhancement-mode, power MOSFETs used as high-side or low-side switches. The MIC5016/7 can sustain an on-state output indefinitely.

The MIC5016/7 operates from a 2.75V to 30V supply. In high-side configurations, the driver can control MOSFETs that switch loads of up to 30V. In low-side configurations, with separate supplies, the maximum switched voltage is limited only by the MOSFET.

The MIC5016/7 has two TTL compatible control inputs. The MIC5016 is noninverting while the MIC5017 is inverting.

The MIC5016/7 features internal charge pumps that can sustain gate voltages greater than the available supply voltage. The driver is capable of turning on logic-level MOSFETs from a 2.75V supply or standard MOSFETs from a 5V supply. Gate-to-source output voltages are internally limited to approximately 15V.

The MIC5016/7 is protected against automotive load dump, reversed battery, and inductive load spikes of -20V. The driver's overvoltage shutdown feature turns off the external MOSFETs at approximately 35V to protect the load against power supply excursions.

The MIC5016 is an improved pin-for-pin compatible replacement in many MIC5012 applications.

The MIC5016/7 is available in plastic 14-pin DIP and 16-pin SOIC packages.

Features

- 2.75V to 30V operation
- 100µA maximum supply current (5V supply)
- 15µA typical off-state current
- Internal charge pump
- TTL compatible input
- Withstands 60V transient (load dump)
- Reverse battery protected to -20V
- Inductive spike protected to -20V
- Overvoltage shutdown at 35V
- Internal 15V gate protection
- Minimum external parts
- Operates in high-side or low-side configurations
- 1µA control input pull-off
- Inverting and noninverting versions

Applications

- Automotive electrical load control
- Battery-powered computer power management
- Lamp control
- Heater control
- Motor control
- Power bus switching

Ordering Information

Part Number	Temperature Range	Package
Noninverting		
MIC5016BWM	-40°C to +85°C	16-pin Wide SOIC
MIC5016BN	-40°C to +85°C	14-pin Plastic DIP
Inverting		
MIC5017BWM	-40°C to +85°C	16-pin Wide SOIC
MIC5017BN	-40°C to +85°C	14-pin Plastic DIP

Typical Application

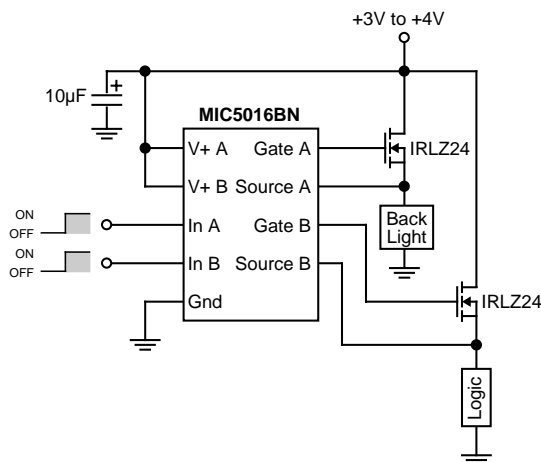
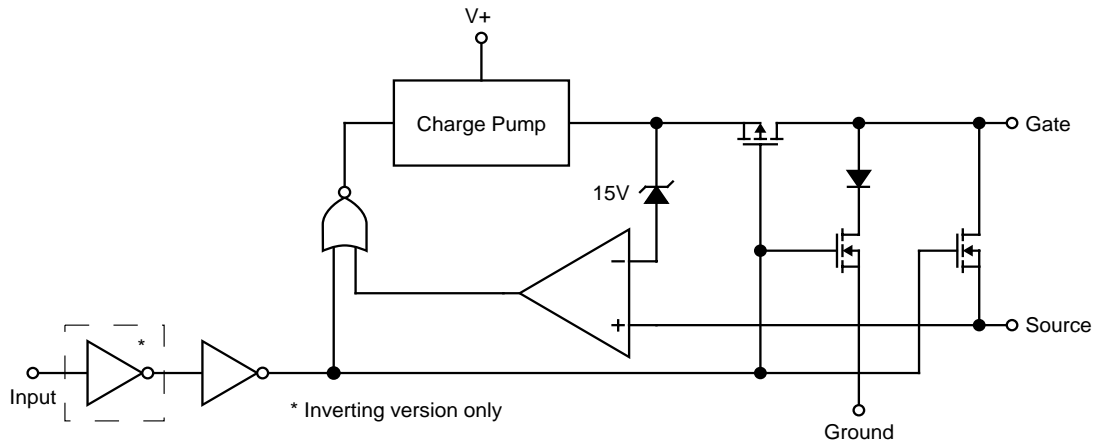
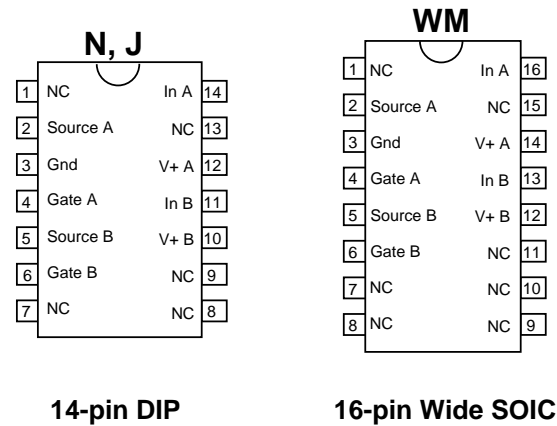

Figure 1: 3-Volt "Sleep-Mode" Switches with Logic-Level MOSFETs

Block Diagram 1 of 2 Drivers per Package



Connection Diagram



Pin Description

Pin Number N, J Package	Pin Number WM Package	Pin Name	Pin Function
12	14	V ⁺ A	Supply Pin A. Must be decoupled to isolate large transients caused by power MOSFET drain. 10 μ F is recommended close to pins 12 and/or 10 and ground. V ⁺ A and V ⁺ B may be connected to separate supplies.
10	12	V ⁺ B	Supply Pin B. See V ⁺ A.
14	16	Input A	Turns on power MOSFET A when asserted. Requires approximately 1 μ A to switch.
11	13	Input B	Turns on power MOSFET B. See Input A.
4	4	Gate A	Drives and clamps the gate of power MOSFET A
6	6	Gate B	Drives and clamps the gate of power MOSFET B
2	2	Source A	Connects the source lead of MOSFET A
5	5	Source B	Connects the source lead of MOSFET B
3	3	Gnd	Ground

Absolute Maximum Ratings (Notes 1,2)

Supply Voltage	-20V to 60V
Input Voltage	-20V to V ⁺
Source Voltage	-20V to V ⁺
Source Current	50mA
Gate Voltage	-20V to 50V
Junction Temperature	150°C

Operating Ratings (Notes 1,2)

θ_{JA} (Plastic DIP)	140°C/W
θ_{JA} (SOIC)	110°C/W
Ambient Temperature: B version	-40°C to +85°C
Ambient Temperature: A version	+55°C to +125°C
Storage Temperature	-65°C to +150°C
Lead Temperature	260°C
(max soldering time: 10 seconds)	
Supply Voltage (V ⁺)	2.75V to 30V

Electrical Characteristics (Note 3) T_A = -55°C to +125°C unless otherwise specified

Parameter	Conditions		Min	Typ	Max	Units
Supply Current (Each Driver Channel)	V ⁺ = 30V	V _{IN} De-Asserted (Note 5)		10	25	μA
		V _{IN} Asserted (Note 5)		5.0	10	mA
	V ⁺ = 5V	V _{IN} De-Asserted		10	25	μA
		V _{IN} Asserted		60	100	
	V ⁺ = 3V	V _{IN} De-Asserted		10	25	μA
		V _{IN} Asserted		25	35	
Logic Input Voltage Threshold V _{IN}	3.0V ≤ V ⁺ ≤ 30V T _A = 25°C	Digital Low Level			0.8	V
		Digital High Level	2.0			
Logic Input Current MIC5016 (non-inverting)	3.0V ≤ V ⁺ ≤ 30V	V _{IN} Low	-2.0	0		μA
		V _{IN} High		1.0	2.0	
Logic Input Current MIC5017 (inverting)	3.0V ≤ V ⁺ ≤ 30V	V _{IN} Low	-2.0	-1.0		μA
		V _{IN} High		-1.0	2.0	
Input Capacitance				5.0		pF
Gate Enhancement V _{GATE} - V _{SUPPLY}	3.0V ≤ V ⁺ ≤ 30V	V _{IN} Asserted	4.0		17	V
Zener Clamp V _{GATE} - V _{SOURCE}	8.0V ≤ V ⁺ ≤ 30V	V _{IN} Asserted	13	15	17	V
Gate Turn-on Time, t _{ON} (Note 4)	V ⁺ = 4.5V C _L = 1000pF	V _{IN} switched on, measure time for V _{GATE} to reach V ⁺ + 4V		2.5	8.0	ms
	V ⁺ = 12V C _L = 1000pF	As above, measure time for V _{GATE} to reach V ⁺ + 4V		90	140	μs
Gate Turn-off Time, t _{OFF} (Note 4)	V ⁺ = 4.5V C _L = 1000pF	V _{IN} switched off, measure time for V _{GATE} to reach 1V		6.0	30	μs
	V ⁺ = 12V C _L = 1000pF	As above, measure time for V _{GATE} to reach 1V		6.0	30	μs
Overshoot Shutdown Threshold			35	37	41	V

Note 1: Absolute Maximum Ratings indicate limits beyond which damage to the device may occur. Electrical specifications do not apply when operating the device beyond its specified **Operating Ratings**.

Note 2: The MIC5016/5017 is ESD sensitive.

Note 3: Minimum and maximum **Electrical Characteristics** are 100% tested at T_A = 25°C and T_A = 85°C, and 100% guaranteed over the entire operating temperature range. Typical values are characterized at 25°C and represent the most likely parametric norm.

Note 4: Test conditions reflect worst case high-side driver performance. Low-side and bootstrapped topologies are significantly faster—see Applications Information. Maximum value of switching time seen at 125°C, unit operated at room temperature will reflect the typical value shown.

Note 5: "Asserted" refers to a logic high on the MIC5016 and a logic low on the MIC5017.

Typical Characteristics All data measured using FET probe to minimize resistive loading

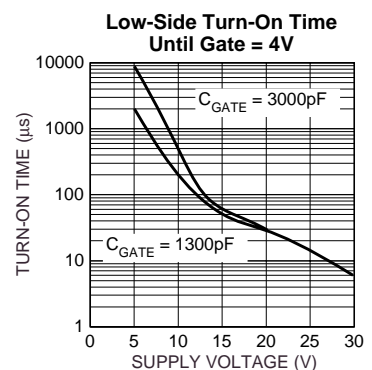
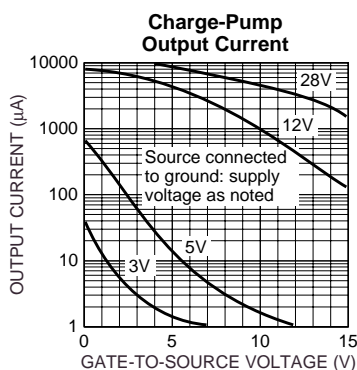
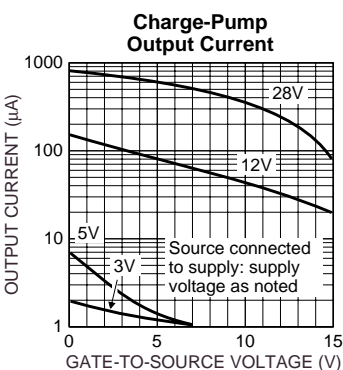
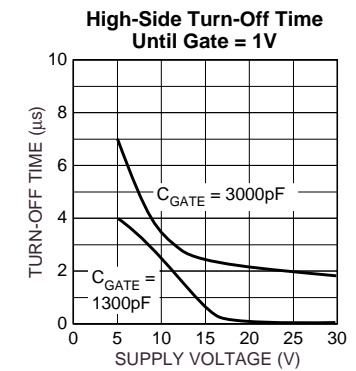
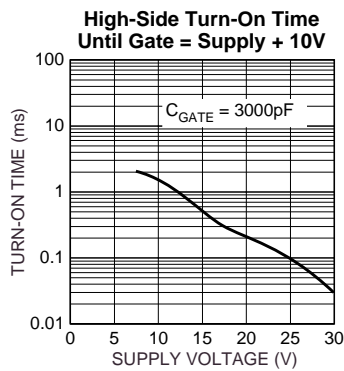
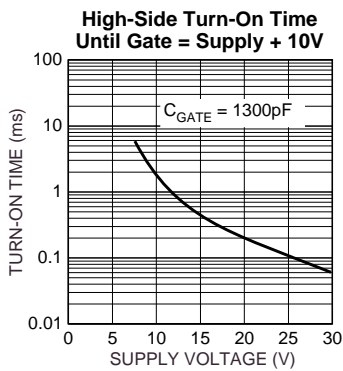
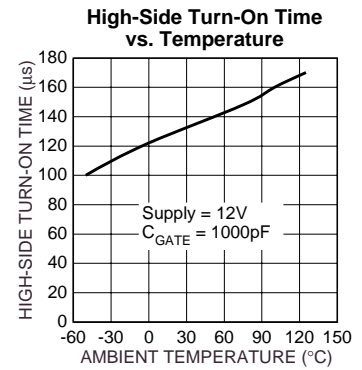
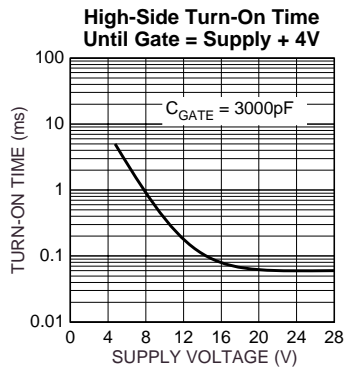
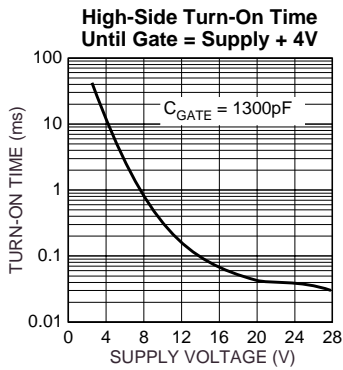
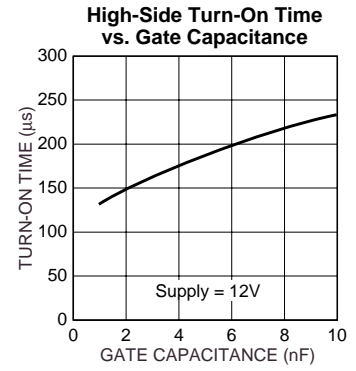
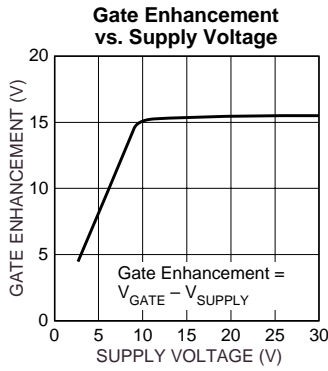
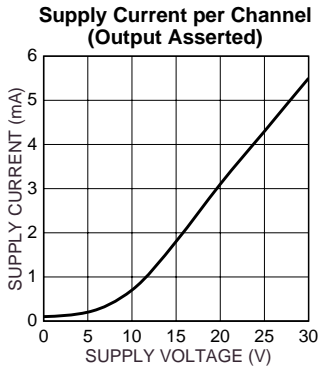

Applications Information

Functional Description

The MIC5016 is functionally compatible with the MIC5012, and the MIC5017 is an inverting configuration of the MIC5016.

The internal functions of these devices are controlled via a logic block (refer to block diagram) connected to the control input (pin 14). When the input is off (low for the MIC5016, and high for the MIC5017), all functions are turned off, and the gate of the external power MOSFET is held low via two N-channel switches. This results in a very low standby current; 15 μ A typical, which is necessary to power an internal bandgap. When the input is driven to the "ON" state, the N-channel switches are turned off, the charge pump is turned on, and the P-channel switch between the charge pump and the gate turns on, allowing the gate of the power FET to be charged. The op amp and internal zener form an active regulator which shuts off the charge pump when the gate voltage is high enough. This is a feature not found on the MIC5012.

The charge pump incorporates a 100kHz oscillator and on-chip pump capacitors capable of charging a 1,000pF load in 90 μ s typical. In addition to providing active regulation, the internal 15V zener is included to prevent exceeding the V_{GS} rating of the power MOSFET at high supply voltages.

The MIC5016/17 devices have been improved for greater ruggedness and durability. All pins can withstand being pulled 20V below ground without sustaining damage, and the supply pin can withstand an overvoltage transient of 60V for 1s. An overvoltage shutdown has also been included, which turns off the device when the supply reaches 35V.

Construction Hints

High current pulse circuits demand equipment and assembly techniques that are more stringent than normal, low current lab practices. The following are the sources of pitfalls most often encountered during prototyping: *Supplies*: Many bench power supplies have poor transient response. Circuits that are being pulse tested, or those that operate by pulse-width modulation will produce strange results when used with a supply that has poor ripple rejection, or a peaked transient response. Always monitor the power supply voltage that appears at the drain of a high side driver (or the supply side of the load for a low side driver) with an oscilloscope. It is not uncommon to find bench power supplies in the 1kW class that overshoot or undershoot by as much as 50% when pulse loaded. Not only will the load current and voltage measurements be affected, but it is possible to overstress various components, especially electrolytic capacitors, with possibly catastrophic results. A 10 μ F supply bypass capacitor *at the chip* is recommended. *Residual resistances*: Resistances in circuit connections may also cause confusing results. For example, a circuit may employ a 50m Ω power MOSFET for low voltage drop, but unless careful construction techniques are used, one could easily add 50 to 100m Ω resistance. Do not use a socket for the MOSFET. If the MOSFET is a TO-220 type package, make high current connections to the drain tab. Wiring

losses have a profound effect on high-current circuits. A floating milliohmeter can identify connections that are contributing excess drop under load.

Low Voltage Testing As the MIC5016/5017 have relatively high output impedances, a normal oscilloscope probe will load the device. This is especially pronounced at low voltage operation. It is recommended that a FET probe or unity gain buffer be used for all testing.

Circuit Topologies

The MIC5016 and MIC5017 are well suited for use with standard power MOSFETs in both low and high side driver configurations. In addition, the lowered supply voltage requirements of these devices make them ideal for use with logic level FETs in high side applications with a supply voltage of 3V to 4V. (If higher supply voltages [$>4V$] are used with logic level FETs, an external zener clamp must be supplied to ensure that the maximum V_{GS} rating of the logic FET [10V] is not exceeded). In addition, a standard IGBT can be driven using these devices.

Choice of one topology over another is usually based on speed vs. safety. The fastest topology is the low side driver, however, it is not usually considered as safe as high side driving as it is easier to accidentally short a load to ground than to V_{CC} . The slowest, but safest topology is the high side driver; with speed being inversely proportional to supply voltage. It is the preferred topology for most military and automotive applications. Speed can be improved considerably by bootstrapping the supply.

All topologies implemented using these devices are well suited to driving inductive loads, as either the gate or the source pin can be pulled 20V below ground with no effect. External clamp diodes are unnecessary, except for the case in which a transient may exceed the overvoltage trip point.

High Side Driver (Figure 1) The high side topology shown here is an implementation of a "sleep-mode" switch for a laptop or notebook computer which uses a logic level FET. A standard power FET can easily be substituted when supply voltages above 4V are required.

Low Side Driver (Figure 2) A key advantage of this topology, as previously mentioned, is speed. The MOSFET gate is

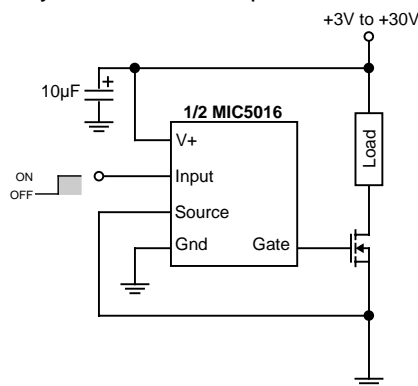

Figure 2. Low Side Driver

driven to near supply immediately when the MIC5016/17 is turned on. Typical circuits reach full enhancement in 50µs or less with a 15V supply.

Bootstrapped High Side Driver (Figure 3) The turn-on time of a high side driver can be improved to faster than 40µs by bootstrapping the supply with the MOSFET source. The Schottky barrier diode prevents the supply pin from dropping more than 200mV below the drain supply, and improves turn-on time. Since the supply current in the "OFF" state is only a small leakage, the 100nF bypass capacitor tends to remain charged for several seconds after the MIC5016/17 is turned off. Faster switching speeds can be obtained at the expense of supply voltage (the overvoltage shutdown will turn the part off when the bootstrapping action pulls the supply pin above 35V) by using a larger capacitor at the junction of the two 1N4001 diodes. In a PWM application (this circuit can be used for either PWM'ed or continuously energized loads), the chip supply is sustained at a higher potential than the system supply, which improves switching time.

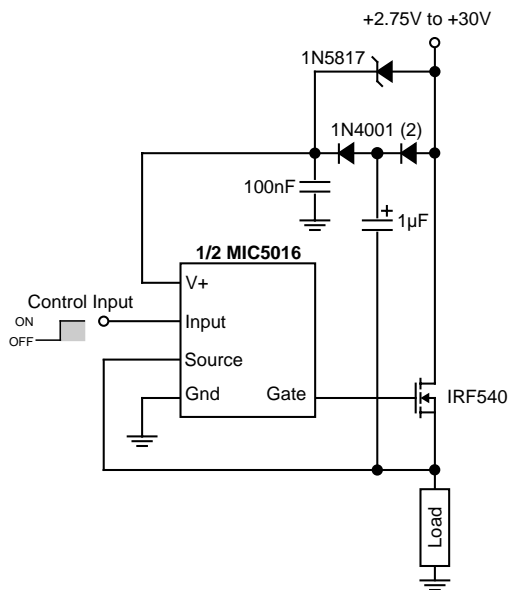

Figure 3. Bootstrapped High-Side Driver

High Side Driver With Current Sense (Figure 4) Although no current sense function is included on the MIC5016/17 devices, a simple current sense function can be realized via the addition of one more active component; an LM301A op amp used as a comparator. The positive rail of the op amp is tied to V⁺, and the negative rail is tied to ground. This op amp was chosen as it can withstand having input transients that swing below the negative rail, and has common mode range almost to the positive rail.

The inverting side of this comparator is tied to a voltage divider which sets the voltage to V⁺ - V_{TRIP}. The noninverting side is tied to the node between the drain of the FET and the sense resistor. If the overcurrent trip point is not exceeded, this node will always be above V⁺ - V_{TRIP}, and the output of the comparator will be high which feeds the control input of the MIC5016 (polarities should be reversed if the MIC5017 is used). Once the overcurrent trip point has been reached, the comparator

will go low, which shuts off the MIC5016. When the short is removed, feedback to the input pin insures that the MIC5016 will turn back on. This output can also be level shifted and sent to an I/O port of a microcontroller for intelligent control.

Current Shunts (R_S). Low valued resistors are necessary for use at R_S. Resistors are available with values ranging from 1 to 50mΩ, at 2 to 10W. If a precise overcurrent trip point is not necessary, then a nonprecision resistor or even a measured PCB trace can serve as R_S. The major cause of drift in resistor values with such resistors is temperature coefficient; the designer should be aware that a linear, 500ppm/°C change will contribute as much as 10% shift in the overcurrent trip point.

If this is not acceptable, a power resistor designed for current shunt service (drifts less than 100ppm/°C), or a Kelvin-sensed resistor may be used.†

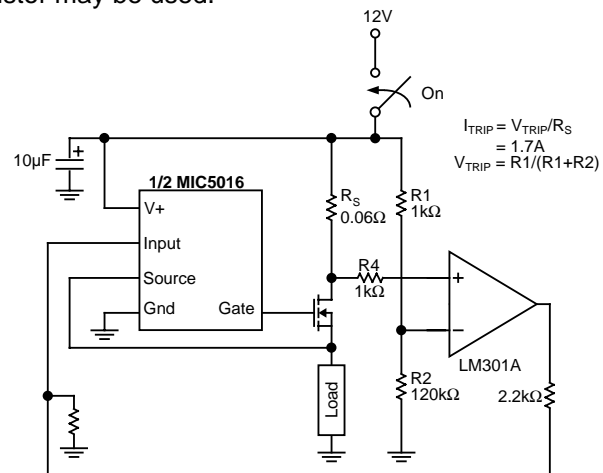

Figure 4. High Side Driver with Overcurrent Shutdown

† Suppliers of Precision Power Resistors:

Dale Electronics, Inc., 2064 12th Ave., Columbus, NE 68601. (402) 565-3131
International Resistive Co., P.O. Box 1860, Boone, NC 28607-1860.

(704) 264-8861

Isotek Corp., 566 Wilbur Ave. Swansea, MA 02777. (508) 673-2900

Kelvin, 14724 Ventura Blvd., Ste. 1003, Sherman Oaks, CA 91403-3501.

(818) 990-1192

RCD Components, Inc., 520 E. Industrial Pk. Dr., Manchester, NH 03103.

(603) 669-0054

Ultronix, Inc., P.O. Box 1090, Grand Junction, CO 81502 (303) 242-0810

High Side Driver With Delayed Current Sense (Figure 5) Delay of the overcurrent detection to accommodate high inrush loads such as incandescent or halogen lamps can be accomplished by adding an LM3905 timer as a one shot to provide an open collector pulldown for the comparator output such that the control input of the MIC5017 stays low for a preset amount of time without interference from the current sense circuitry. Note that an MIC5017 must be used in this application (figure 5), as an inverting control input is necessary. The delay time is set by the RC time constant of the external components on pins 3 and 4 of the timer; in this case, 6ms was chosen.

An LM3905 timer was used instead of a 555 as it provides a clean transition, and is almost impossible to make oscillate. Good bypassing and noise immunity is essential in this circuit to prevent spurious op amp oscillations.

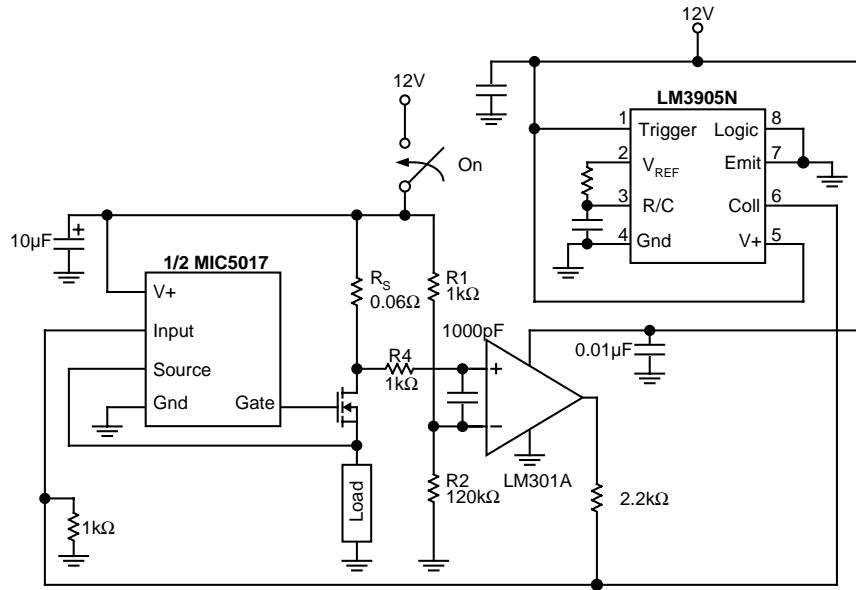

Figure 5. High Side Driver with Delayed Overcurrent Shutdown

Typical Applications

Variable Supply Low Side Driver for Motor Speed Control (Figure 6) The internal regulation in the MIC5016/17 allows a steady gate enhancement to be supplied while the MIC5016/17 supply varies from 5V to 30V, without damaging the internal gate to source zener clamp. This allows the speed of the DC motor shown to be varied by varying the supply voltage.

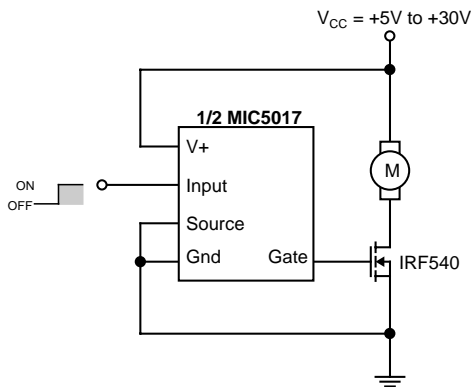

Figure 6: DC Motor Speed Control/Driver

Solenoid Valve Driver (Figure 7) High power solenoid valves are used in many industrial applications requiring the timed dispensing of chemicals or gases. When the solenoid is activated, the valve opens (or closes), releasing (or stopping) fluid flow. A solenoid valve, like all inductive loads, has a considerable “kickback” voltage when turned off, as current cannot change instantaneously through an inductor. In most

applications, it is acceptable to allow this voltage to momentarily turn the MOSFET back on as a way of dissipating the inductor's current. However, if this occurs when driving a solenoid valve with a fast switching speed, chemicals or gases may inadvertently be dispensed at the wrong time with possibly disastrous consequences. Also, too large of a kickback voltage (as is found in larger solenoids) can damage the MIC5016 or the power FET by forcing the Source node below ground (the MIC5016 can be driven up to 20V below ground before this happens). A catch diode has been included in this design to provide an alternate route for the inductive kickback current to flow. The 5kΩ resistor in series with this diode has been included to set the recovery time of the solenoid valve.

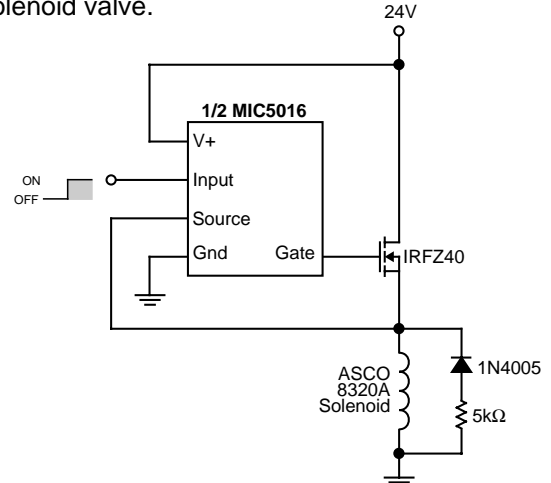

Figure 7: Solenoid Valve Driver

Incandescent/Halogen Lamp Driver (Figure 8) The combination of an MIC5016/5017 and a power FET makes an effective driver for a standard incandescent or halogen lamp load. Such loads often have high inrush currents, as the resistance of a cold filament is less than one-tenth as much as when it is hot. Power MOSFETs are well suited to this application as they have wider safe operating areas than do power bipolar transistors. It is important to check the SOA curve on the data sheet of the power FET to be used against the estimated or measured inrush current of the lamp in question prior to prototyping to prevent “explosive” results.

If overcurrent sense is to be used, first measure the duration of the inrush, then use the topology of Figure 5 with the RC of the timer chosen to accommodate the duration with suitable guardbanding.

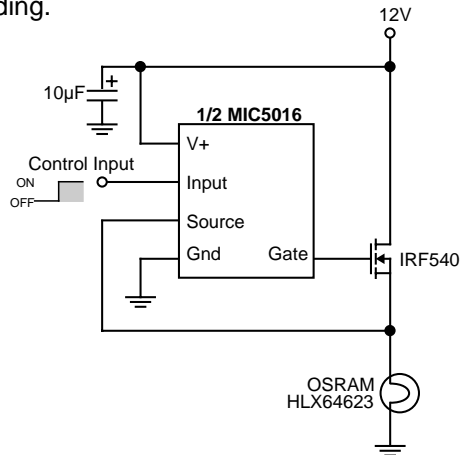

Figure 8: Halogen Lamp Driver

Relay Driver (Figure 9) Some power relay applications require the use of a separate switch or drive control, such as in the case of microprocessor control of banks of relays where a logic level control signal is used, or for drive of relays with high power requirements. The combination of an MIC5016/5017 and a power FET also provides an elegant solution to power relay drive.

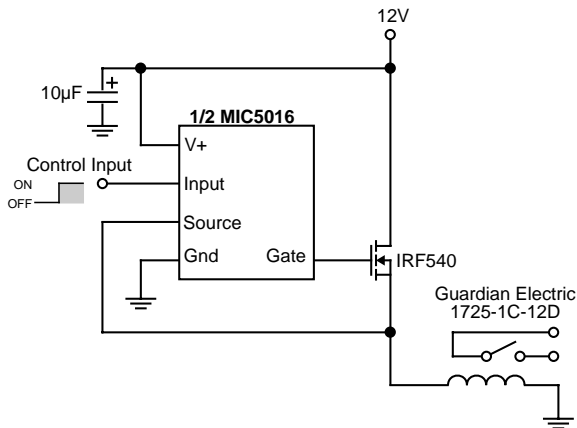

Figure 9: Relay Driver

Motor Driver With Stall Shutdown (Figure 10) Tachometer feedback can be used to shut down a motor driver circuit when a stall condition occurs. The control switch is a 3-way type; the “START” position is momentary and forces the driver ON. When released, the switch returns to the “RUN” position, and the tachometer’s output is used to hold the MIC5016 input ON. If the motor slows down, the tach output is reduced, and the MIC5016 switches OFF. Resistor “R” sets the shutdown threshold.

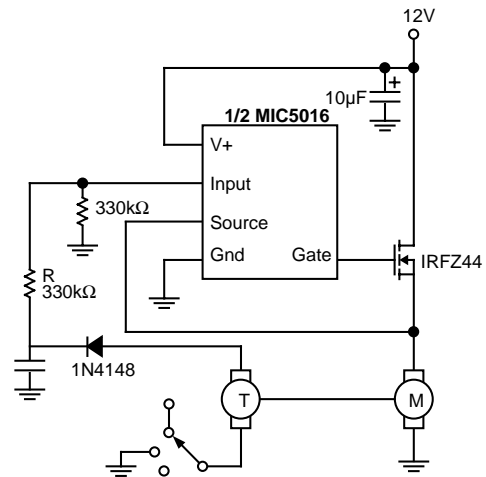

Figure 10. Motor Stall Shutdown

Simple DC-DC Converter (Figure 11) The simplest application for the MIC5016 is as a basic one-chip DC-DC converter. As the output (Gate) pin has a relatively high impedance, the output voltage shown will vary significantly with applied load.

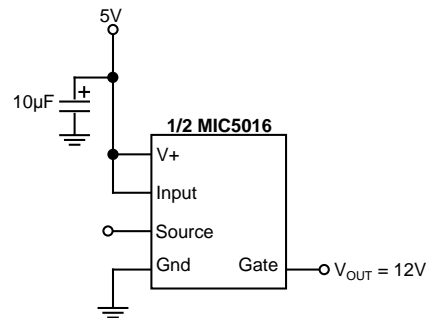

Figure 11. DC - DC Converter

High Side Driver With Load Protection (Figure 12) Although the MIC5016/17 devices are reverse battery protected, the load and power FET are not in a typical high side configuration. In the event of a reverse battery condition, the internal body diode of the power FET will be forward biased. This allows the reversed supply to drive the load.

An MBR2035CT dual Schottky diode was used to eliminate this problem. This particular diode can handle 20A continuous current and 150A peak current; therefore it should survive the rigors of an automotive environment. The diodes are paralleled to reduce the switch loss (forward voltage drop).

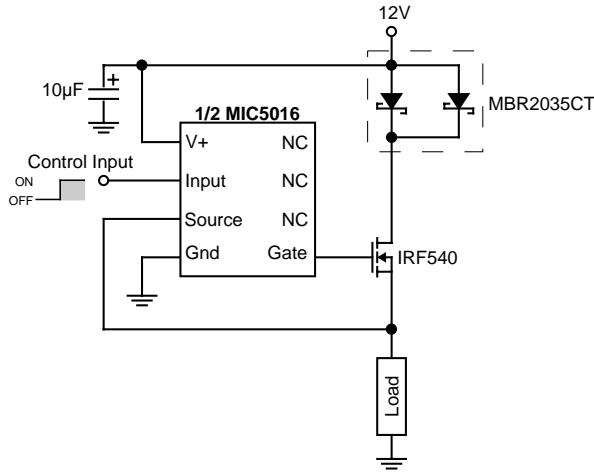

Figure 12: High Side Driver With Load Protection

Push-Pull Driver With No Cross-Conduction (Figure 13) As the turn-off time of the MIC5016/17 devices is much faster than the turn-on time, a simple dual push-pull driver with no cross conduction can be made using one MIC5016 and one MIC5017. The same control signal is applied to both inputs; the MIC5016 turns on with the positive signal, and the MIC5017 turns on when it swings low.

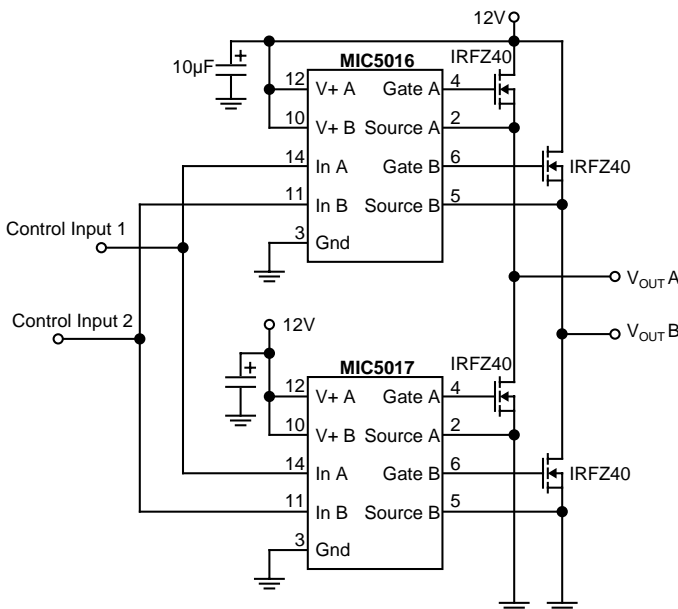

Figure 13: Push-Pull Driver

This scheme works with no additional components as the relative time difference between the rise and fall times of the MIC5014 is large. However, this does mean that there is considerable deadtime (time when neither driver is turned on). If this circuit is used to drive an inductive load, catch diodes must be used on each half to provide an alternate path for the kickback current that will flow during this deadtime.

This circuit is also a simple H-bridge which can be driven with a PWM signal on the input for SMPS or motor drive applications in which high switching frequencies are not desired.

Synchronous Rectifier (Figure 14) In applications where efficiency in terms of low forward voltage drops and low diode reverse-recovery losses is critical, power FETs are used to achieve rectification instead of a conventional diode bridge. Here, the power FETs are used in the third quadrant of the IV characteristic curve (FETs are installed essentially “backwards”). The two FETs are connected such that the top FET turns on with the positive going AC cycle, and turns off when it swings negative. The bottom FET operates opposite to the top FET.

In the first quadrant of operation, the limitation of the device is determined by breakdown voltage. Here, we are limited by the turn-on of a parasitic p-n body drain diode. If it is allowed to conduct, its reverse recovery time will crowbar the other power FET and possibly destroy it. The way to prevent this is to keep the IR drop across the device below the cut-in voltage of this diode; this is accomplished here by using a fast comparator to sense this voltage and feed the appropriate signal to the control inputs of the MIC5016 device. Obviously, it is very important to use a comparator with a fast slew rate such as the LM393, and fast recovery diodes. 3mV of positive feedback is used on the comparator to prevent oscillations.

At 3A, with an $R_{DS(ON)}$ of 0.077Ω, our forward voltage drop per FET is ~ 0.2 V as opposed to the 0.7 to 0.8 V drop that a normal diode would have. Even greater savings can be had by using FETs with lower $R_{DS(ON)}$ s, but care must be taken that the peak currents and voltages do not exceed the SOA of the chosen FET.

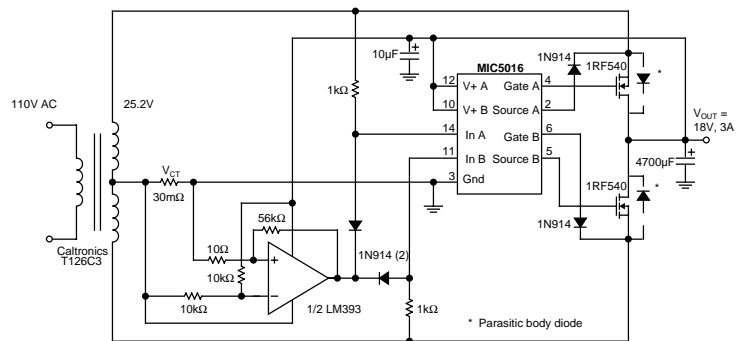
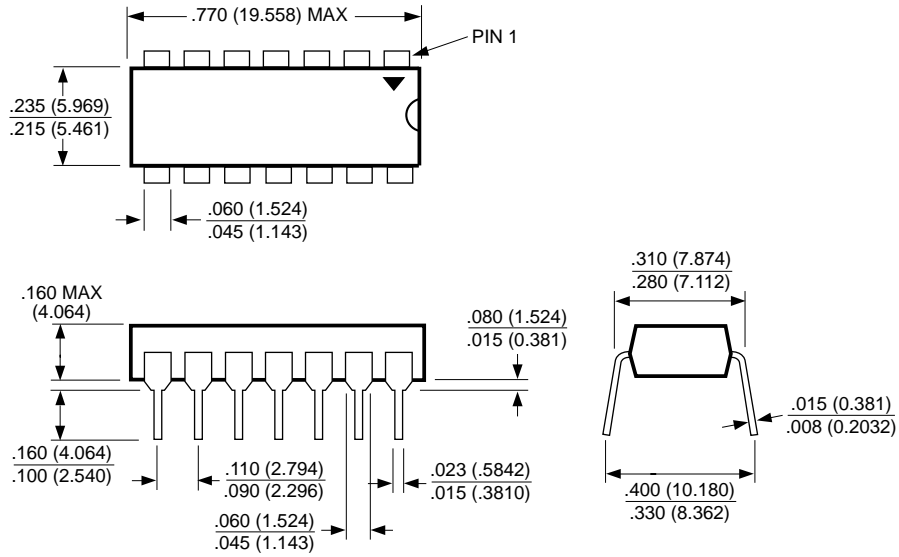
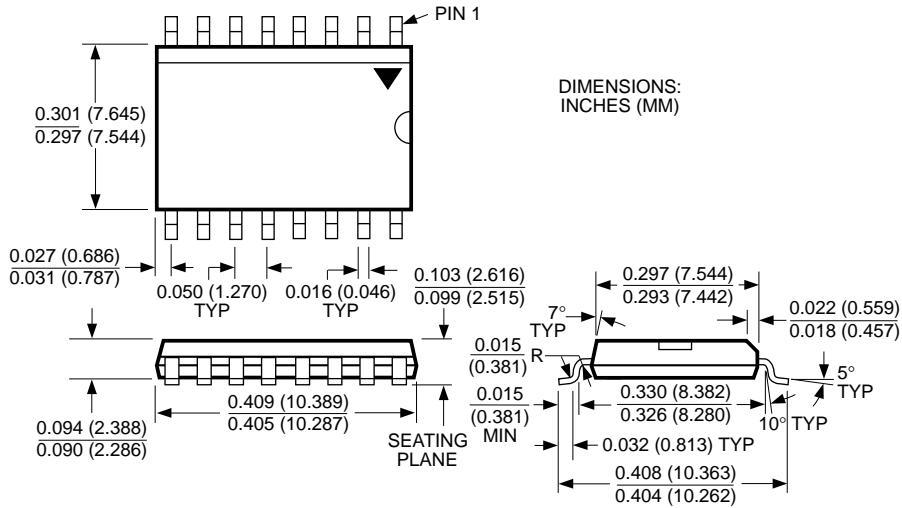

Figure 14: High Efficiency 60 Hz Synchronous Rectifier

Package Information



14-Pin Plastic DIP (N)



16-Pin Wide SOP (M)

MICREL INC. 1849 FORTUNE DRIVE SAN JOSE, CA 95131 USA

TEL + 1 (408) 944-0800 FAX + 1 (408) 944-0970 WEB <http://www.micrel.com>

This information is believed to be accurate and reliable, however no responsibility is assumed by Micrel for its use nor for any infringement of patents or other rights of third parties resulting from its use. No license is granted by implication or otherwise under any patent or patent right of Micrel Inc.

© 1998 Micrel Incorporated