

ZXGD3101T8

Synchronous rectifier controller for flyback converters.

Description

The ZXGD3101 is intended to drive MOSFETS configured as ideal diode replacements. The device is comprised of a differential amplifier detector stage and high current driver. The detector monitors the reverse voltage of the MOSFET such that if body diode conduction occurs a positive voltage is applied to the MOSFET's Gate pin.

Once the positive voltage is applied to the Gate the MOSFET switches on allowing reverse current flow. The detectors' output voltage is then proportional to the MOSFET Drain-Source reverse voltage drop and this is applied to the Gate via the driver. This action provides a rapid turn off as current decays.

Features

- Turn-off propagation delay 15ns and turn-off time 20ns
- Suitable for Discontinuous Mode (DCM), Critical Conduction Mode (CrCM) and Continuous conduction mode (CCM) operation
- Compliant with Energy Star V2.0 and European Code of Conduct V3
- Low component count
- Halogen free
- 5-15V V_{CC} range

Applications

Flyback converters in:

- Adaptors
- LCD monitors
- Server PSU's
- Set top boxes

Refer to documents; AN54, DN90, DN91 and DN94 available from the website

Pin out detail

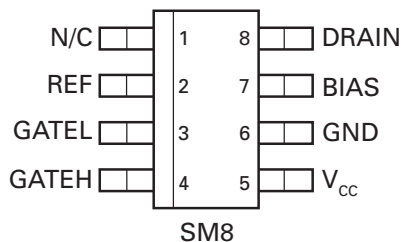

Typical configuration

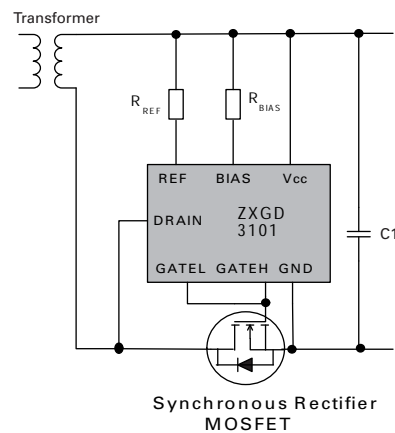

Ordering information

Device	Status	Package	Part Mark	Reel size (inches)	Tape width (mm)	Quantity per reel
ZXGD3101T8TA	Active	SM8	ZXGD3101	7	12	1000

ZXGD3101T8

Absolute maximum ratings

Parameter	Symbol	Limit	Unit
Supply voltage ¹	V_{CC}	15	V
Continuous Drain pin voltage ¹	V_D	-3 to 180	V
GATEH and GATEL output Voltage ¹	V_G	-3 to $V_{CC} + 3$	V
Driver peak source current	I_{SOURCE}	4	A
Driver peak sink current	I_{SINK}	7	A
Reference current	I_{REF}	25	mA
Bias voltage	V_{BIAS}	V_{CC}	V
Bias current	I_{BIAS}	100	mA
Power dissipation at $T_A = 25^\circ\text{C}$	P_D	500	mW
Operating junction temperature	T_j	-40 to +150	$^\circ\text{C}$
Storage temperature	T_{stg}	-50 to +150	$^\circ\text{C}$

NOTES:

1. All voltages are relative to GND pin

Thermal resistance

Parameter	Symbol	Value	Unit
Junction to ambient (*)	$R_{\theta JA}$	250	$^\circ\text{C}/\text{W}$
Junction to lead (†)	$R_{\theta IA}$	54	$^\circ\text{C}/\text{W}$

NOTES:

(*) Mounted on minimum 1oz copper on FR4 PCB in still air conditions

(†) Output Drivers - Junction to solder point at end of the lead 5 and 6

ESD Rating

Model	Rating	Unit
Human body	4,000	V
Machine	400	V

ZXGD3101T8

Electrical characteristics at $T_A = 25^\circ\text{C}$;

$V_{CC} = 10\text{V}$; $R_{BIAS} = 1.8\text{k}\Omega$; $R_{REF} = 3\text{k}\Omega$

Parameter	Symbol	Conditions	Min.	Typ.	Max.	Unit
Input and supply characteristics						
Operating current	I_{OP}	$V_{DRAIN} \leq -200\text{mV}$	-	3	-	mA
		$V_{DRAIN} \geq 0\text{V}$	-	8	-	
Gate Driver						
Turn-off Threshold Voltage(**)	V_T	$V_G = 1\text{V}, (*)$	-45	-16	0	mV
GATE output voltage (**)	$V_{G(off)}$	$V_{DRAIN} \geq 0\text{V}, (*)$	-	0.6	1	V
		$V_{DRAIN} = -60\text{mV}, (\dagger)$	5.0	7.5	-	
	$V_{DRAIN} = -80\text{mV}, (\dagger)$	7.0	8.5	-		
	$V_{DRAIN} = -100\text{mV}, (\dagger)$	8.4	9	-		
	$V_{DRAIN} \leq -140\text{mV}, (\dagger)$	9.2	9.4	-		
	$V_{DRAIN} \leq -200\text{mV}, (\dagger)$	9.3	9.5	-		
GATEH peak source current	I_{SOURCE}	$V_{GH} = 1\text{V}$		2.5	-	A
GATEL peak sink current	I_{SINK}	$V_{GL} = 5\text{V}$		2.5	-	A
Turn on Propagation delay	t_{d1}	$C_L = 2.2\text{nF}, (\dagger) (a)$		525		ns
Turn off Propagation delay	t_{d2}			15		ns
Gate rise time	t_r			305		ns
Gate fall time	t_f			20		ns

NOTES:

(**) GATEH connected to GATEL

(*) $R_H = 100\text{k}\Omega$, $R_L = 0/\text{C}$

(†) $R_L = 100\text{k}\Omega$, $R_H = 0/\text{C}$

(a) (Refer to Fig 4; Test circuit and Fig 5; Timing diagram on page 11

ZXGD3101T8

Schematic symbol and pin description

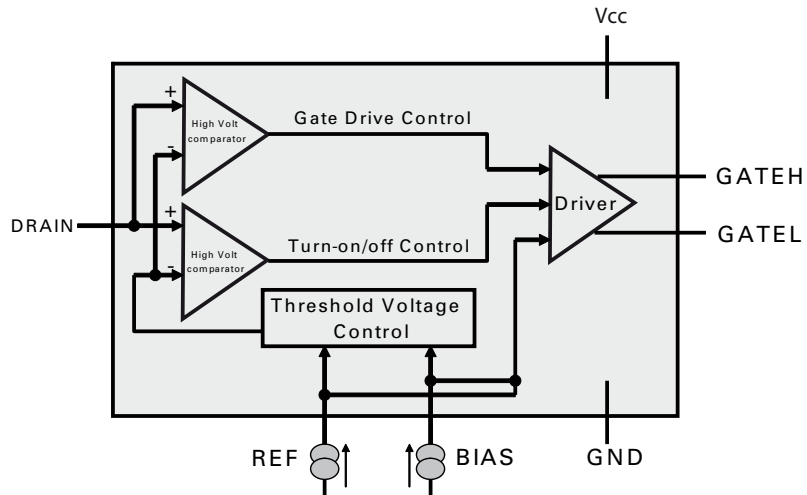

Pin No.	Symbol	Description and function
1	NC	No connection This pin can be connected to GND
2	REF	Reference This pin is connected to V_{CC} via resistor, R_{REF} . R_{REF} should be selected to source $\sim 3\text{mA}$ into this pin. See note 1
3	GATEL	Gate turn off This pin sinks current, I_{SINK} , from the synchronous MOSFET Gate.
4	GATEH	Gate turn on This pin sources current, I_{SOURCE} , to the synchronous MOSFET Gate.
5	V_{CC}	Power Supply This is the supply pin. It is recommended to decouple this point to ground closely with a ceramic capacitor.
6	GND	Ground This is the ground reference point. Connect to the synchronous MOSFET Source terminal.
7	BIAS	Bias This pin is connected to V_{CC} via resistor, R_{BIAS} . R_{BIAS} should be selected to source 1.6 times I_{REF} into this pin. See note 1
8	DRAIN	Drain connection This pin connects directly to the synchronous MOSFET Drain terminal.

NOTES:

- BIAS and REF pins should be assumed to be at $GND+0.7V$

Operation

Normal Operation

The operation of the device is described step-by-step with reference to the timing diagram below.

1. The detector monitors the MOSFET Drain-Source voltage.
2. When, due to transformer action, the MOSFET body diode is forced to conduct there is approximately -0.6V on the Drain pin.
3. The detector outputs a positive voltage with respect to ground, this voltage is then fed to the MOSFET driver stage and current is sourced out of the GATEH pin.
4. The current out of the GATEH pin is sourced into the synchronous MOSFET Gate to turn the device on.
5. The GATEH output voltage is now proportional to the Drain-Source voltage drop across the MOSFET due to the current flowing through the MOSFET.
6. MOSFET conduction continues until the drain current reaches zero.
7. At zero current the detector output voltage is zero and the synchronous MOSFET Gate voltage is pulled low by the GATEL, turning the device off.

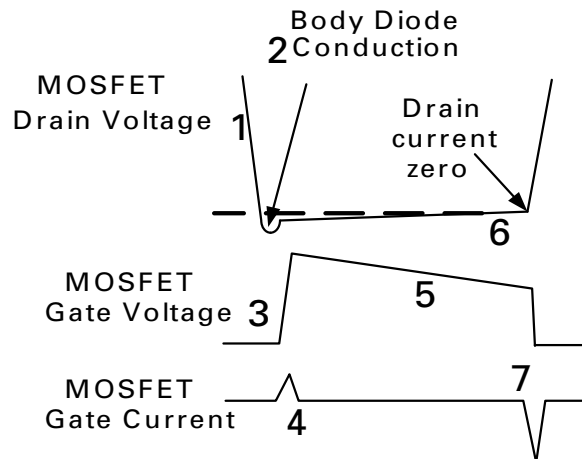

ZXGD3101T8

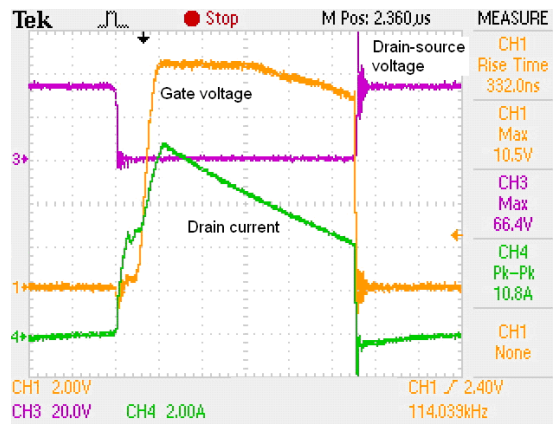

Fig 1a: Continuous Conduction Mode (CCM)

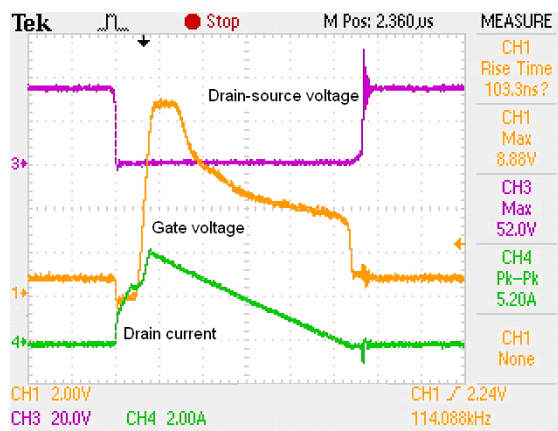

Fig 1b: Critical Conduction Mode (CrCM)

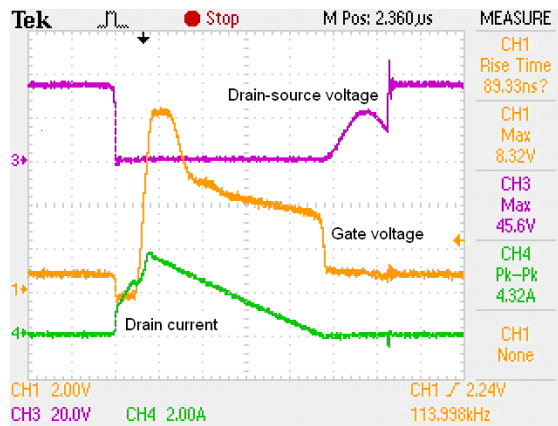
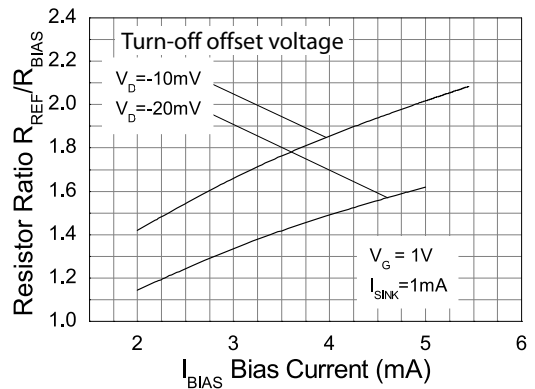
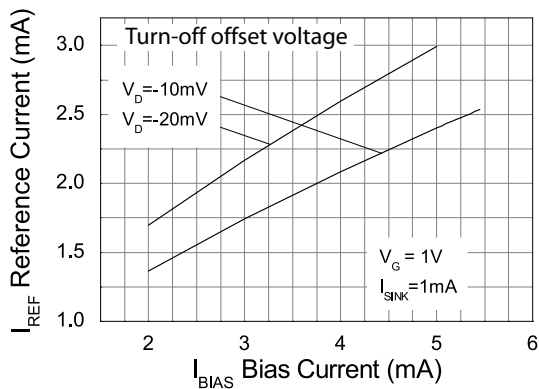
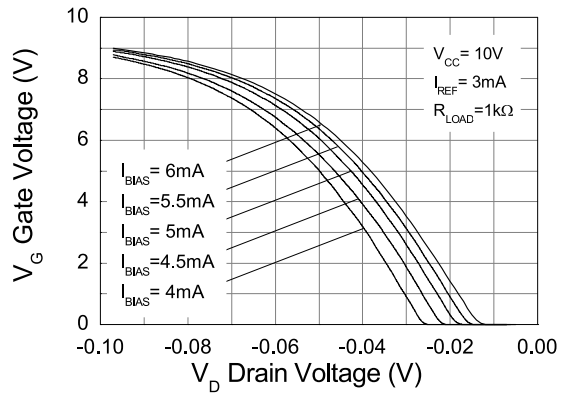
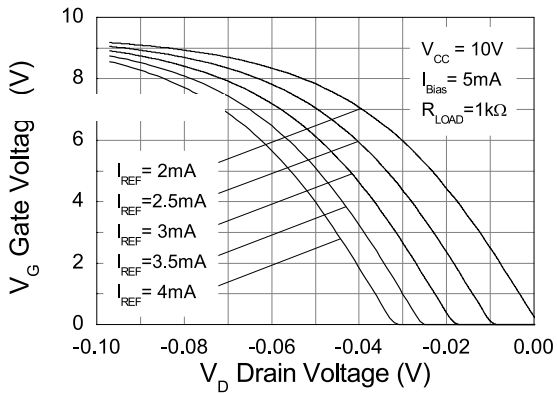
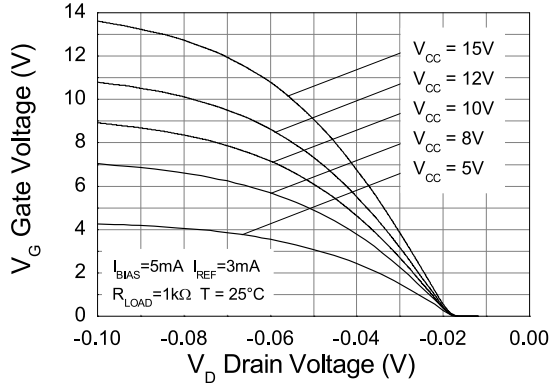
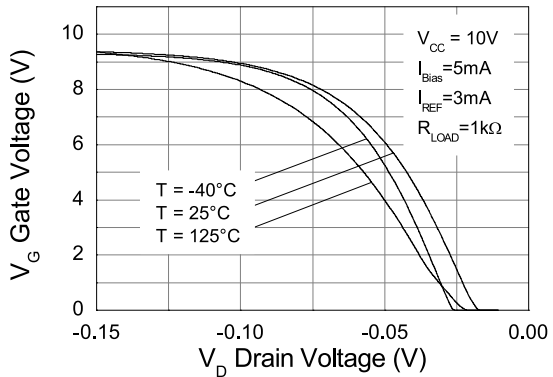

Fig 1c: Discontinuous Conduction Mode (DCM)

Figure 1. Typical waveforms

Typical characteristics



Typical characteristics

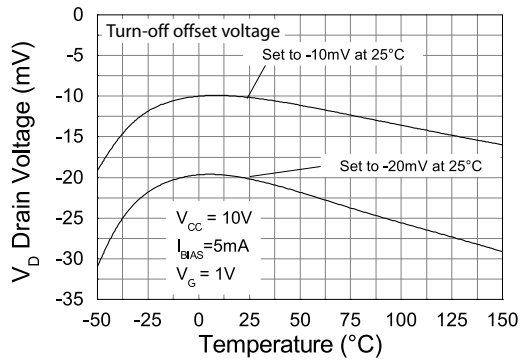

Drain Sense Voltage vs Temperature

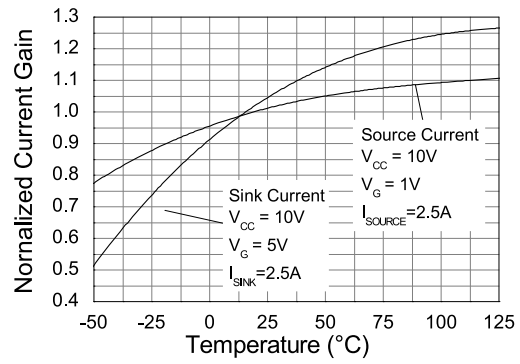

Output Current vs Temperature

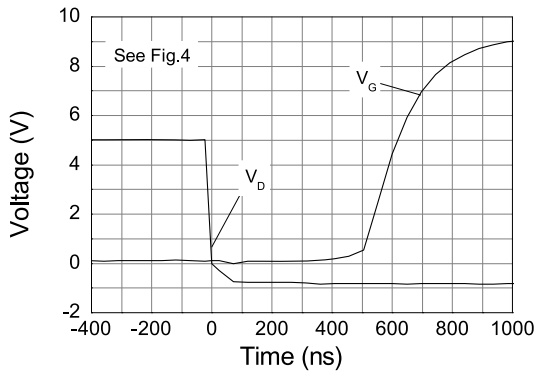

Switch On Speed

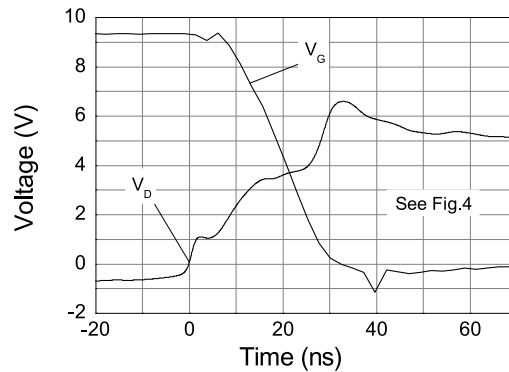

Switch Off Speed

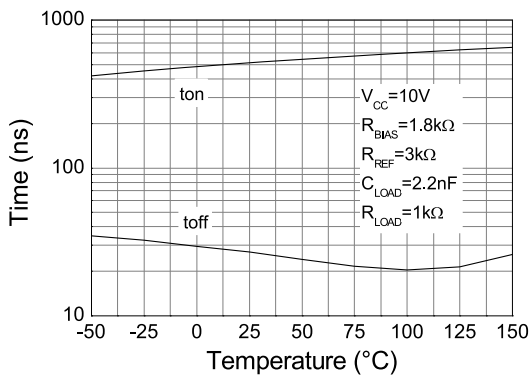

Switching vs Temperature

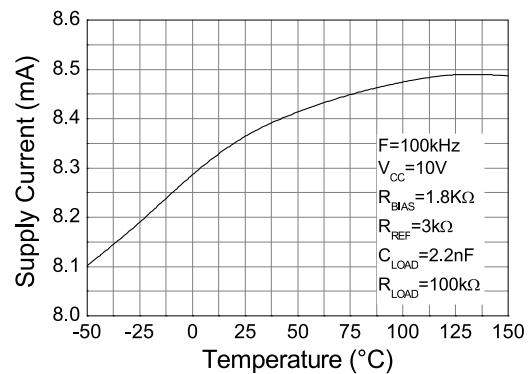

Supply Current vs Temperature

Typical characteristics

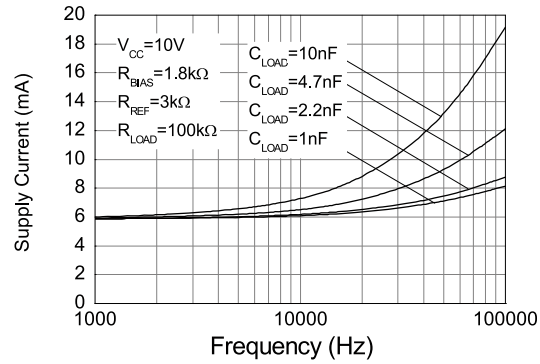
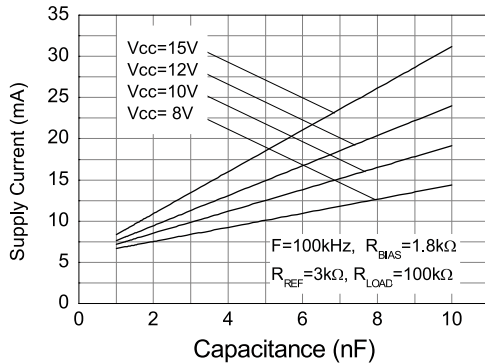

Component selection

It is advisable to decouple the ZXGD3101 closely to V_{CC} and ground due to the possibility of high peak gate currents with C1 in Figure 2.

The proper selection of external resistors R_{REF} and R_{BIAS} is important to the optimum device operation. Select a value for resistor R_{REF} to give a reference current, I_{REF} of $\sim 3mA$. The value of R_{BIAS} must then be 0.6 times the value of R_{REF} to give a bias current, I_{BIAS} , of 1.6 times I_{REF} . This provides a recommended typical offset voltage of $-20mV$.

External gate resistors are optional. They can be inserted to control the rise times which may help with EMI issues, power supply consumption issues or dissipation within the part.

$$R_{REF} = (V_{CC} - 0.7V) / 0.003$$

$$R_{BIAS} = (V_{CC} - 0.7V) / 0.005$$

Layout considerations

The Gate pins should be as close to the MOSFET Gate as possible. Also the ground return loop should be as short as possible. The decoupling capacitor should be close to the V_{CC} and Ground pin, and should be a X7R type.

For more detailed information refer to application note AN54.

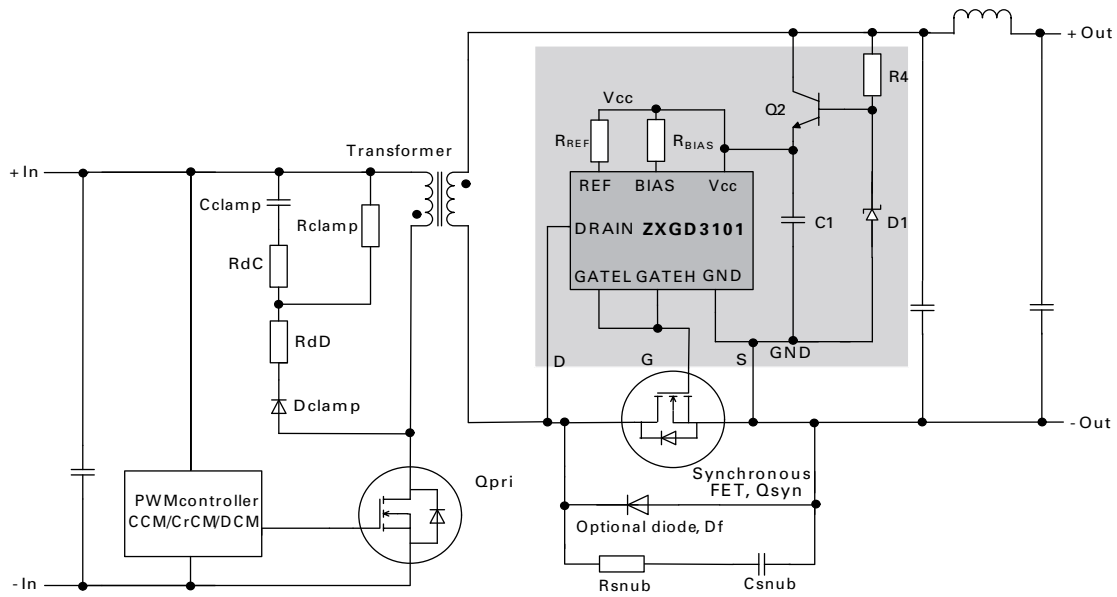

Figure 2 - Example connection for low side synchronous rectification

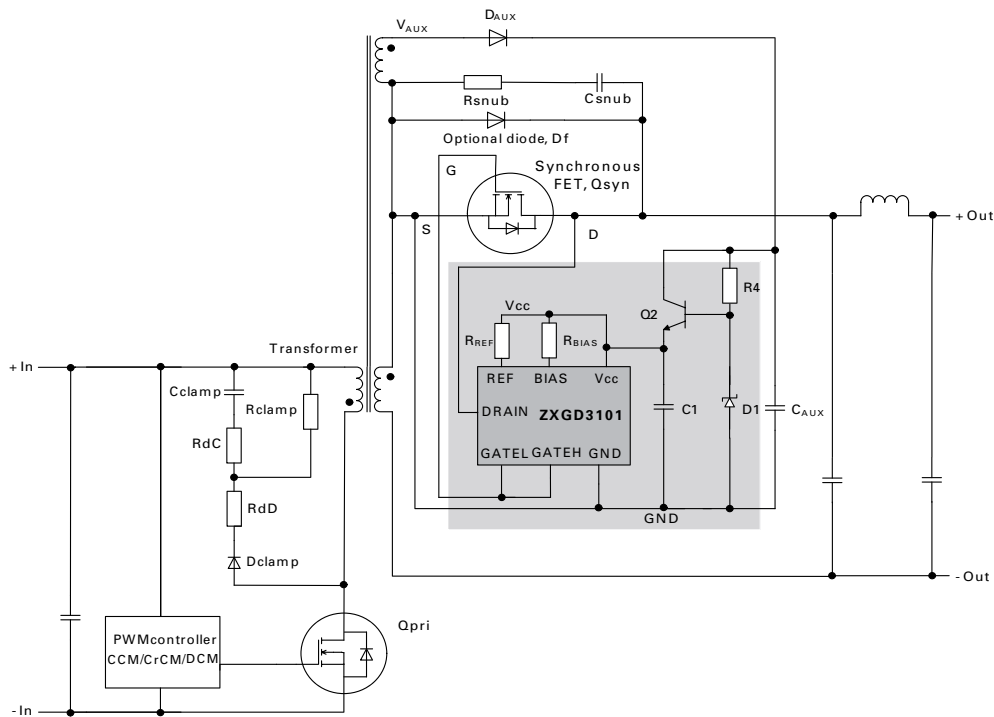

Figure 3 - Example connection for high side synchronous rectification

ZXGD3101T8

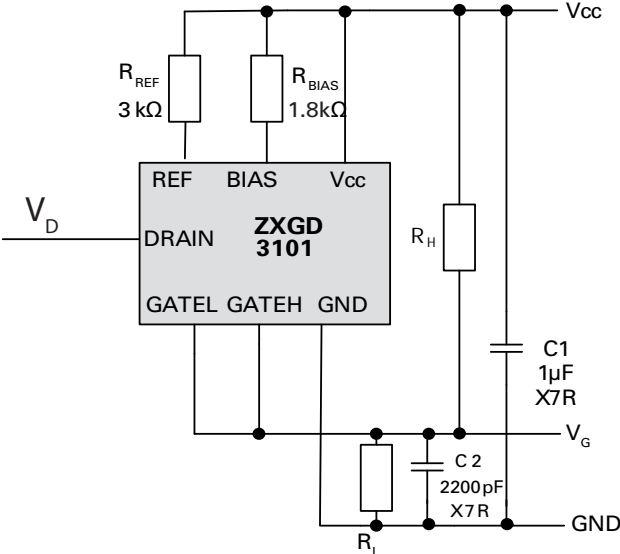
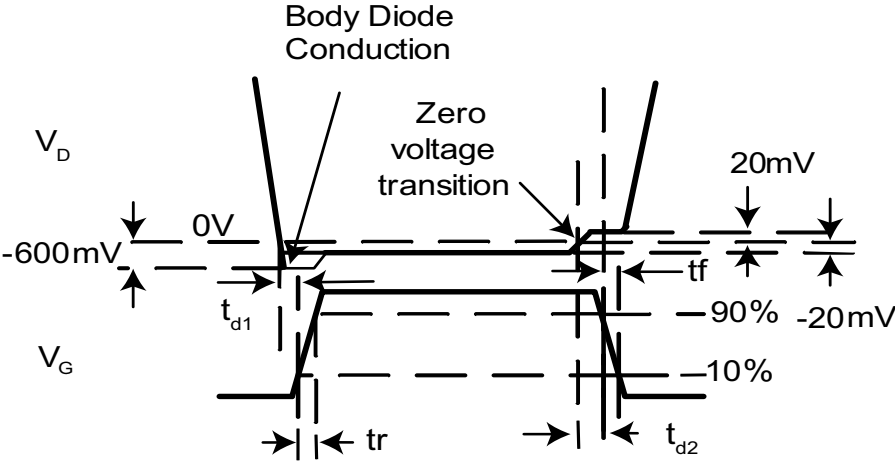

Figure 4: Test circuit



NOTE: GATE H AND GATE L ARE CONNECTED

Figure 5: Timing diagram

ZXGD3101T8

Package information - SM8 (Surface mounted, 8 pin package)

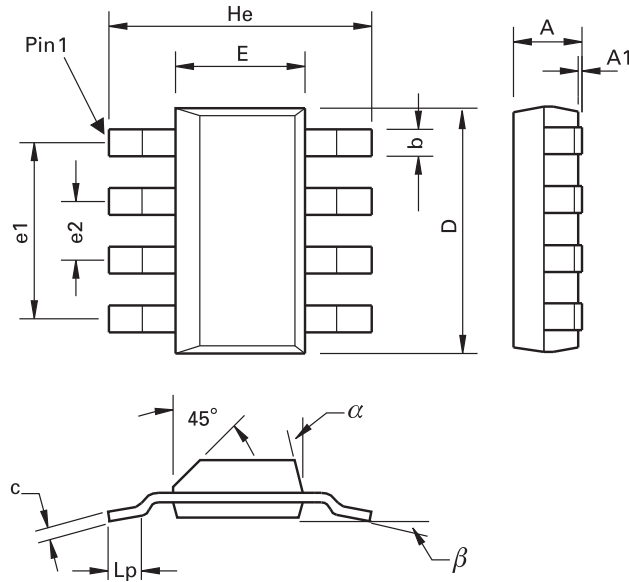

DIM	Millimeters			Inches			DIM	Millimeters			Inches		
	Min.	Max.	Typ.	Min.	Max.	Typ.		Min.	Max.	Typ.	Min.	Max.	Typ.
A	-	1.7	-	-	0.067	-	e1	-	-	4.59	-	-	0.1807
A1	0.02	0.1	-	0.0008	0.004	-	e2	-	-	1.53	-	-	0.0602
b	-	-	0.7	-	-	0.0275	He	6.7	7.3	-	0.264	0.287	-
c	0.24	0.32	-	0.009	0.013	-	Lp	0.9	-	-	0.035	-	-
D	6.3	6.7	-	0.248	0.264	-	α	-	15°	-	-	15°	-
E	3.3	3.7	-	0.130	0.145	-	β	-	-	10°	-	-	10°

Note: Controlling dimensions are in millimeters. Approximate dimensions are provided in inches

Soldering footprint

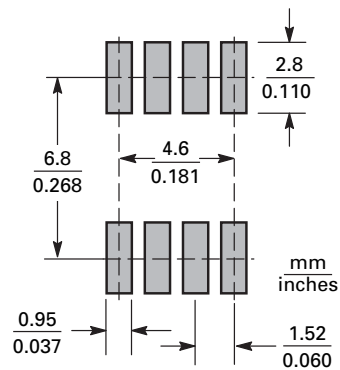

ZXGD3101T8

Intentionally left blank

Definitions

Product change

Diodes Incorporated reserves the right to alter, without notice, specifications, design, price or conditions of supply of any product or service. Customers are solely responsible for obtaining the latest relevant information before placing orders.

Applications disclaimer

The circuits in this design/application note are offered as design ideas. It is the responsibility of the user to ensure that the circuit is fit for the user's application and meets with the user's requirements. No representation or warranty is given and no liability whatsoever is assumed by Diodes Inc. with respect to the accuracy or use of such information, or infringement of patents or other intellectual property rights arising from such use or otherwise. Diodes Inc. does not assume any legal responsibility or will not be held legally liable (whether in contract, tort (including negligence), breach of statutory duty, restriction or otherwise) for any damages, loss of profit, business, contract, opportunity or consequential loss in the use of these circuit applications, under any circumstances.

Life support

Diodes Zetex products are specifically not authorized for use as critical components in life support devices or systems without the express written approval of the Chief Executive Officer of Diodes Incorporated. As used herein:

- A. Life support devices or systems are devices or systems which:
1. are intended to implant into the body
- or
2. support or sustain life and whose failure to perform when properly used in accordance with instructions for use provided in the labelling can be reasonably expected to result in significant injury to the user.
- B. A critical component is any component in a life support device or system whose failure to perform can be reasonably expected to cause the failure of the life support device or to affect its safety or effectiveness.

Reproduction

The product specifications contained in this publication are issued to provide outline information only which (unless agreed by the company in writing) may not be used, applied or reproduced for any purpose or form part of any order or contract or be regarded as a representation relating to the products or services concerned.

Terms and Conditions

All products are sold subjects to Diodes Inc. terms and conditions of sale, and this disclaimer (save in the event of a conflict between the two when the terms of the contract shall prevail) according to region, supplied at the time of order acknowledgement.

For the latest information on technology, delivery terms and conditions and prices, please contact your nearest Diodes or Zetex sales office.

Quality of product

Diodes Zetex Semiconductors Limited is an ISO 9001 and TS16949 certified semiconductor manufacturer.

To ensure quality of service and products we strongly advise the purchase of parts directly from Diodes Inc. or one of our regionally authorized distributors. For a complete listing of authorized distributors please visit: www.zetex.com or www.diodes.com

Diodes Inc. does not warrant or accept any liability whatsoever in respect of any parts purchased through unauthorized sales channels.

ESD (Electrostatic discharge)

Semiconductor devices are susceptible to damage by ESD. Suitable precautions should be taken when handling and transporting devices. The possible damage to devices depends on the circumstances of the handling and transporting, and the nature of the device. The extent of damage can vary from immediate functional or parametric malfunction to degradation of function or performance in use over time. Devices suspected of being affected should be replaced.

Green compliance

Diodes Inc. is committed to environmental excellence in all aspects of its operations which includes meeting or exceeding regulatory requirements with respect to the use of hazardous substances. Numerous successful programs have been implemented to reduce the use of hazardous substances and/or emissions.

All Diodes Zetex components are compliant with the RoHS directive, and through this it is supporting its customers in their compliance with WEEE and ELV directives.

Product status key:

"Preview"	Future device intended for production at some point. Samples may be available
"Active"	Product status recommended for new designs
"Last time buy (LTB)"	Device will be discontinued and last time buy period and delivery is in effect
"Not recommended for new designs"	Device is still in production to support existing designs and production
"Obsolete"	Production has been discontinued

Datasheet status key:

"Draft version"	This term denotes a very early datasheet version and contains highly provisional information, which may change in any manner without notice.
"Provisional version"	This term denotes a pre-release datasheet. It provides a clear indication of anticipated performance. However, changes to the test conditions and specifications may occur, at any time and without notice.
"Issue"	This term denotes an issued datasheet containing finalized specifications. However, changes to specifications may occur, at any time and without notice.

Sales offices

The Americas	Europe	Taiwan	Shanghai	Shenzhen	Korea
3050 E. Hillcrest Drive Westlake Village, CA 91362-3154 Tel: (+1) 805 446 4800 Fax: (+1) 805 446 4850	Kustermann-Park Balanstraße 59, D-81541 München Germany Tel: (+49) 894 549 490 Fax: (+49) 894 549 4949	7F, No. 50, Min Chuan Road Hsin-Tien Taipei, Taiwan Tel: (+886) 289 146 000 Fax: (+886) 289 146 639	Rm. 606, No.1158 Changning Road Shanghai, China Tel: (+86) 215 241 4882 Fax: (+86) 215 241 4891	ANLIAN Plaza, #4018 Jintian Road Futian CBD, Shenzhen, China Tel: (+86) 755 882 849 88 Fax: (+86) 755 882 849 99	6 Floor, Changhwa B/D, 1005-5 Yeongtong-dong, Yeongtong-gu, Suwon-si, Gyeonggi-do, Korea 443-813 Tel: (+82) 312 731 884 Fax: (+82) 312 731 885