

1.5A Dual Open-Drain MOSFET Drivers

Features:

- Independently Programmable Rise and Fall Times
- Low Output Impedance – 7Ω Typ.
- High Speed t_R, t_F – <30 nsec with 1000 pF Load
- Short Delay Times – <30 nsec
- Wide Operating Range:
 - 4.5V to 18V
- Latch-Up Protected: Will Withstand > 500 mA Reverse Current (Either Polarity)
- Input Withstands Negative Swings Up to -5V

Applications:

- Motor Controls
- Driving Bipolar Transistors
- Driver for Non-overlapping Totem Poles
- Reach-Up/Reach-Down Driver

Device Selection Table

Part Number	Package	Temp. Range
TC4404COA	8-Pin SOIC	0°C to +70°C
TC4404CPA	8-Pin PDIP	0°C to +70°C
TC4404EOA	8-Pin SOIC	-40°C to +85°C
TC4404EPA	8-Pin PDIP	-40°C to +85°C
TC4404MJA	8-Pin Cerdip	-55°C to +125°C
TC4405COA	8-Pin SOIC	0°C to +70°C
TC4405CPA	8-Pin PDIP	0°C to +70°C
TC4405EOA	8-Pin SOIC	-40°C to +85°C
TC4405EPA	8-Pin PDIP	-40°C to +85°C
TC4405MJA	8-Pin Cerdip	-55°C to +125°C

General Description:

The TC4404/TC4405 are CMOS buffer-drivers constructed with complementary MOS outputs, where the drains of the totem-pole output have been left separated so that individual connections can be made to the pull-up and pull-down sections of the output. This allows the insertion of drain-current-limiting resistors in the pull-up and/or pull-down sections, allowing the user to define the rates of rise and fall for a capacitive load; or a reduced output swing, if driving a resistive load, or to limit base current, when driving a bipolar transistor. Minimum rise and fall times, with no resistors, will be less than 30 nsec for a 1000 pF load.

For driving MOSFETs in motor-control applications, where slow-ON/fast-OFF operation is desired, these devices are superior to the previously used technique of adding a diode-resistor combination between the driver output and the MOSFET, because they allow accurate control of turn-ON, while maintaining fast turn-OFF and maximum noise immunity for an OFF device.

When used to drive bipolar transistors, these drivers maintain the high speeds common to other Microchip drivers. They allow insertion of a base current-limiting resistor, while providing a separate half-output for fast turn-OFF. By proper positioning of the resistor, either npn or pnp transistors can be driven.

For driving many loads in low-power regimes, these drivers, because they eliminate shoot-through currents in the output stage, require significantly less power at higher frequencies, and can be helpful in meeting low-power budgets.

Package Type

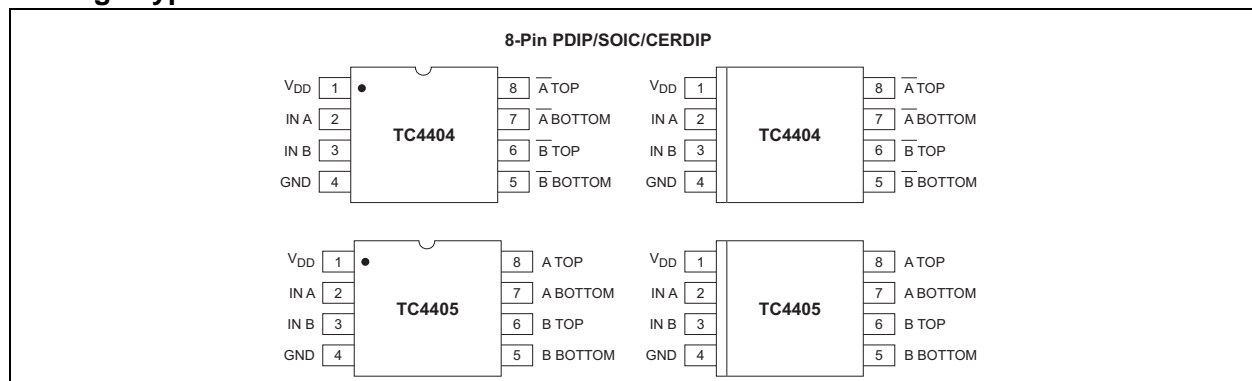

TC4404/TC4405

Because neither drain in an output is dependent on the other, these devices can also be used as open-drain buffer/drivers where both drains are available in one device, thus minimizing chip count. Unused open drains should be returned to the supply rail that their device sources are connected to (pull-downs to ground, pull-ups to V_{DD}), to prevent static damage. In addition, in situations where timing resistors or other means of limiting crossover currents are used, like drains may be paralleled for greater current carrying capacity.

These devices are built to operate in the most demanding electrical environments. They will not latch-up under any conditions within their power and voltage ratings; they are not subject to damage when up to 5V of noise spiking of either polarity occurs on their ground pin; and they can accept, without damage or logic upset, up to 1/2 amp of reverse current (of either polarity) being forced back into their outputs. All terminals are fully protected against up to 2 kV of electrostatic discharge.

Functional Block Diagram

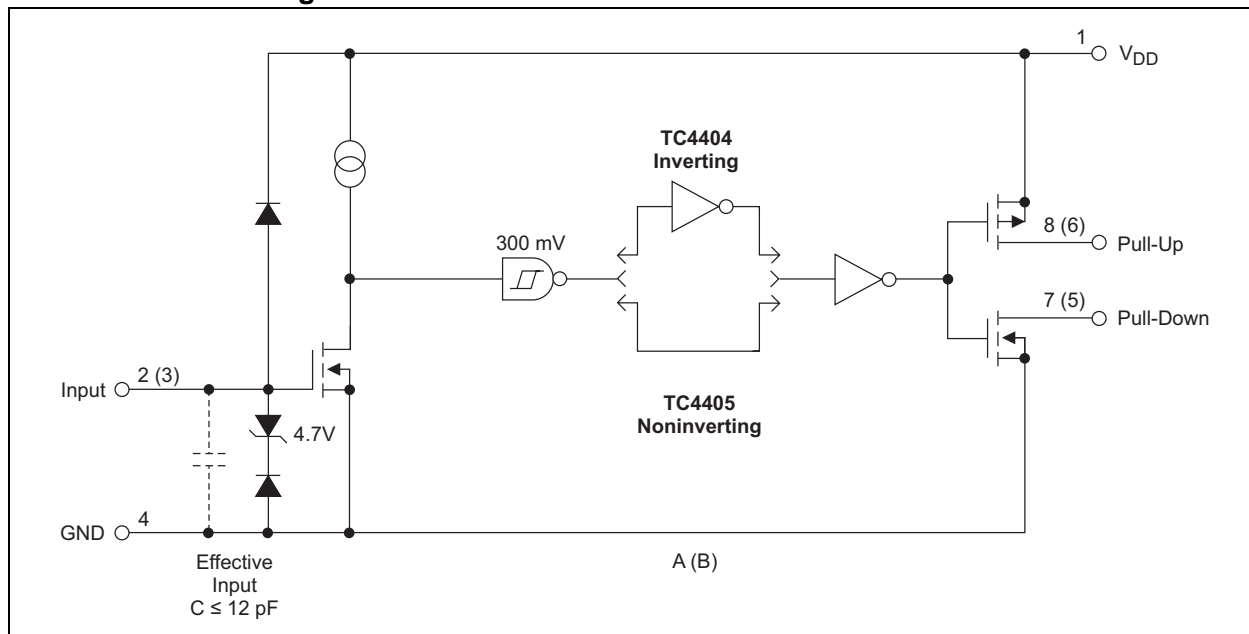

1.0 ELECTRICAL CHARACTERISTICS

Absolute Maximum Ratings*

Supply Voltage	+22V
Power Dissipation ($T_A \leq 70^\circ\text{C}$)	
PDIP	730 mW
CERDIP	800 mW
SOIC	470 mW
Package Thermal Resistance	
PDIP $R_{\theta J-A}$	125°C/W
PDIP $R_{\theta J-C}$	45°C/W
CERDIP $R_{\theta J-A}$	150°C/W
CERDIP $R_{\theta J-C}$	55°C/W
SOIC $R_{\theta J-A}$	155°C/W
SOIC $R_{\theta J-C}$	45°C/W
Operating Temperature Range	
C Version	0°C to +70°C
E Version	-40°C to +85°C
M Version	-55°C to +125°C
Storage Temperature Range	-65°C to +150°C

*Stresses above those listed under “Absolute Maximum Ratings” may cause permanent damage to the device. These are stress ratings only and functional operation of the device at these or any other conditions above those indicated in the operation sections of the specifications is not implied. Exposure to Absolute Maximum Rating conditions for extended periods may affect device reliability.

TC4404/TC4405 ELECTRICAL SPECIFICATIONS

Electrical Characteristics: $T_A = +25^\circ\text{C}$, with $4.5\text{V} \leq V_{DD} \leq 18\text{V}$, unless otherwise noted.						
Symbol	Parameter	Min	Typ	Max	Units	Test Conditions
Input						
V_{IH}	Logic 1, High Input Voltage	2.4	—	—	V	
V_{IL}	Logic 0, Low Input Voltage	—	—	0.8	V	
I_{IN}	Input Current	-1	—	1	μA	$0\text{V} \leq V_{IN} \leq V_{DD}$
Output						
V_{OH}	High Output Voltage	$V_{DD} - 0.025$	—	—	V	
V_{OL}	Low Output Voltage	—	—	0.025	V	
R_O	Output Resistance	—	7	10	Ω	$I_{OUT} = 10\text{ mA}$, $V_{DD} = 18\text{V}$; Any Drain
I_{PK}	Peak Output Current (Any Drain)	—	1.5	—	A	Duty cycle $\leq 2\%$, $t \leq 300\ \mu\text{sec}$
I_{DC}	Continuous Output Current (Any Drain)	—	—	100	mA	
I_R	Latch-Up Protection (Any Drain) Withstand Reverse Current	—	>500	—	mA	Duty cycle $\leq 2\%$, $t \leq 300\ \mu\text{sec}$
Switching Time (Note 1)						
t_R	Rise Time	—	25	30	nsec	Figure 3-1, $C_L = 1000\ \text{pF}$
t_F	Fall Time	—	25	30	nsec	Figure 3-1, $C_L = 1000\ \text{pF}$
t_{D1}	Delay Time	—	15	30	nsec	Figure 3-1, $C_L = 1000\ \text{pF}$
t_{D2}	Delay Time	—	32	50	nsec	Figure 3-1, $C_L = 1000\ \text{pF}$
Power Supply						
I_S	Power Supply Current	—	—	4.5	mA	$V_{IN} = 3\text{V}$ (Both Inputs)
		—	—	0.4		$V_{IN} = 0\text{V}$ (Both Inputs)

Note 1: Switching times ensured by design.

TC4404/TC4405

TC4404/TC4405 ELECTRICAL SPECIFICATIONS (CONTINUED)

Electrical Characteristics: Over operating temperature range with $4.5V \leq V_{DD} \leq 18V$, unless otherwise noted.						
Symbol	Parameter	Min	Typ	Max	Units	Test Conditions
V_{IH}	Logic 1, High Input Voltage	2.4	—	—	V	
V_{IL}	Logic 0, Low Input Voltage	—	—	0.8	V	
I_{IN}	Input Current	-10	—	10	μA	$0V \leq V_{IN} \leq V_{DD}$
Output						
V_{OH}	High Output Voltage	$V_{DD} - 0.025$	—	—	V	
V_{OL}	Low Output Voltage	—	—	0.025	V	
R_O	Output Resistance	—	9	12	Ω	$I_{OUT} = 10 \text{ mA}$, $V_{DD} = 18V$; Any Drain
I_{PK}	Peak Output Current (Any Drain)	—	1.5	—	A	Duty cycle $\leq 2\%$, $t \leq 300 \mu\text{sec}$
I_{DC}	Continuous Output Current (Any Drain)	—	—	100	mA	
I_R	Latch-Up Protection (Any Drain) Withstand Reverse Current	—	>500	—	mA	Duty cycle $\leq 2\%$, $t \leq 300 \mu\text{sec}$
Switching Time (Note 1)						
t_R	Rise Time	—	—	40	nsec	Figure 3-1, $C_L = 1000 \text{ pF}$
t_F	Fall Time	—	—	40	nsec	Figure 3-1, $C_L = 1000 \text{ pF}$
t_{D1}	Delay Time	—	—	40	nsec	Figure 3-1, $C_L = 1000 \text{ pF}$
t_{D2}	Delay Time	—	—	60	nsec	Figure 3-1, $C_L = 1000 \text{ pF}$
Power Supply						
I_S	Power Supply Current	—	—	8	mA	$V_{IN} = 3V$ (Both Inputs)
		—	—	0.6		$V_{IN} = 0V$ (Both Inputs)

Note 1: Switching times ensured by design.

2.0 PIN DESCRIPTIONS

The descriptions of the pins are listed in Table 2-1.

TABLE 2-1: PIN FUNCTION TABLE

Pin No. (8-Pin PDIP, SOIC, CERDIP)	Symbol	Description
1	V _{DD}	Supply input, 4.5V to 18V.
2	IN A	Control input A, TTL/CMOS compatible input.
3	IN B	Control input A, TTL/CMOS compatible input.
4	GND	Ground.
5	B BOTTOM	Output B, pull-down.
6	B TOP	Output B, pull-up.
7	A BOTTOM	Output A, pull-down.
8	A TOP	Output A, pull-up.

TC4404/TC4405

3.0 APPLICATIONS INFORMATION

3.1 Circuit Layout Guidelines

Avoid long power supply and ground traces (added inductance causes unwanted voltage transients). Use power and ground planes wherever possible.

In addition, it is advisable that low ESR bypass capacitors (4.7 μF or 10 μF tantalum) be placed as close to the driver as possible. The driver should be physically located as close to the device it is driving as possible to minimize the length of the output trace.

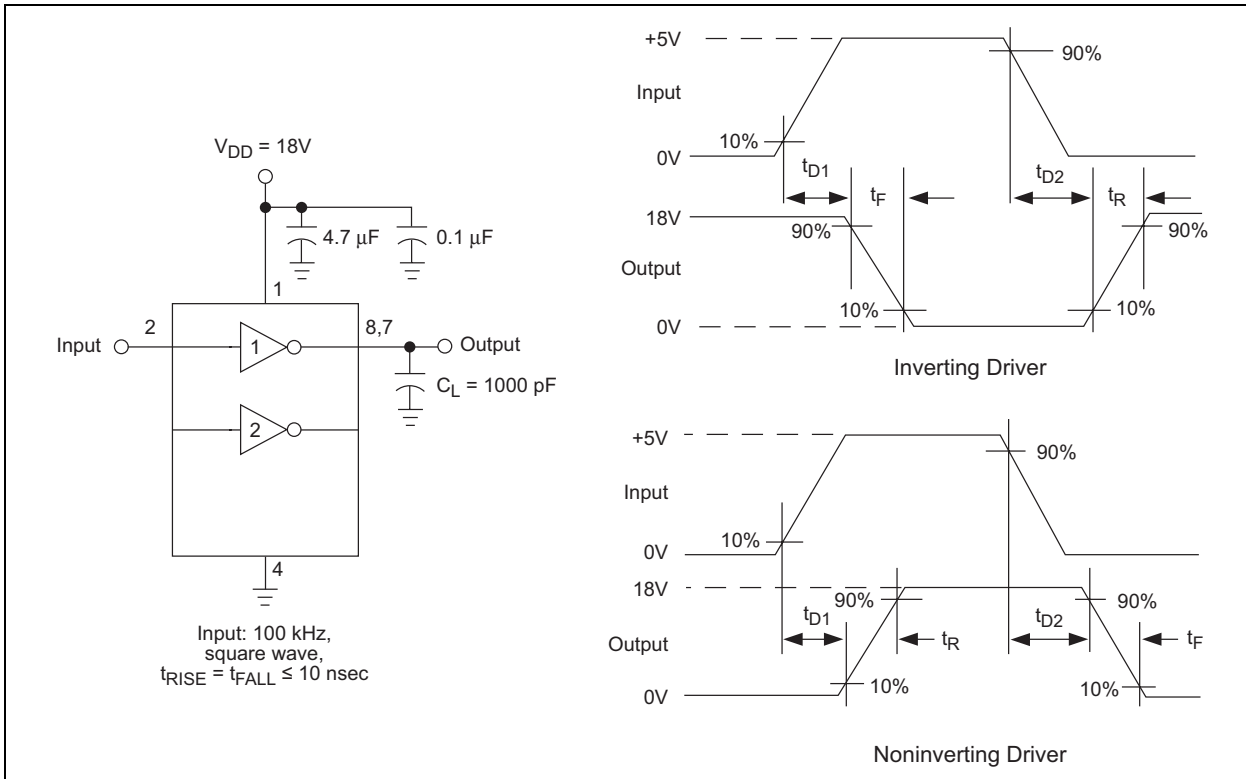

FIGURE 3-1: Switching Time Test Circuit

3.2 Typical Applications

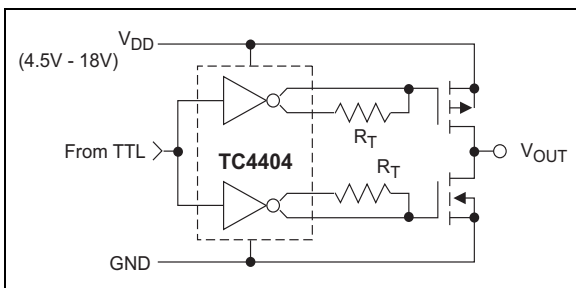

FIGURE 3-2: Zero Crossover Current Totem-Pole Switch

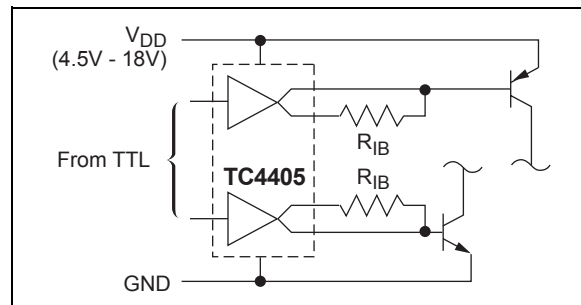

FIGURE 3-3: Driving Bipolar Transistors

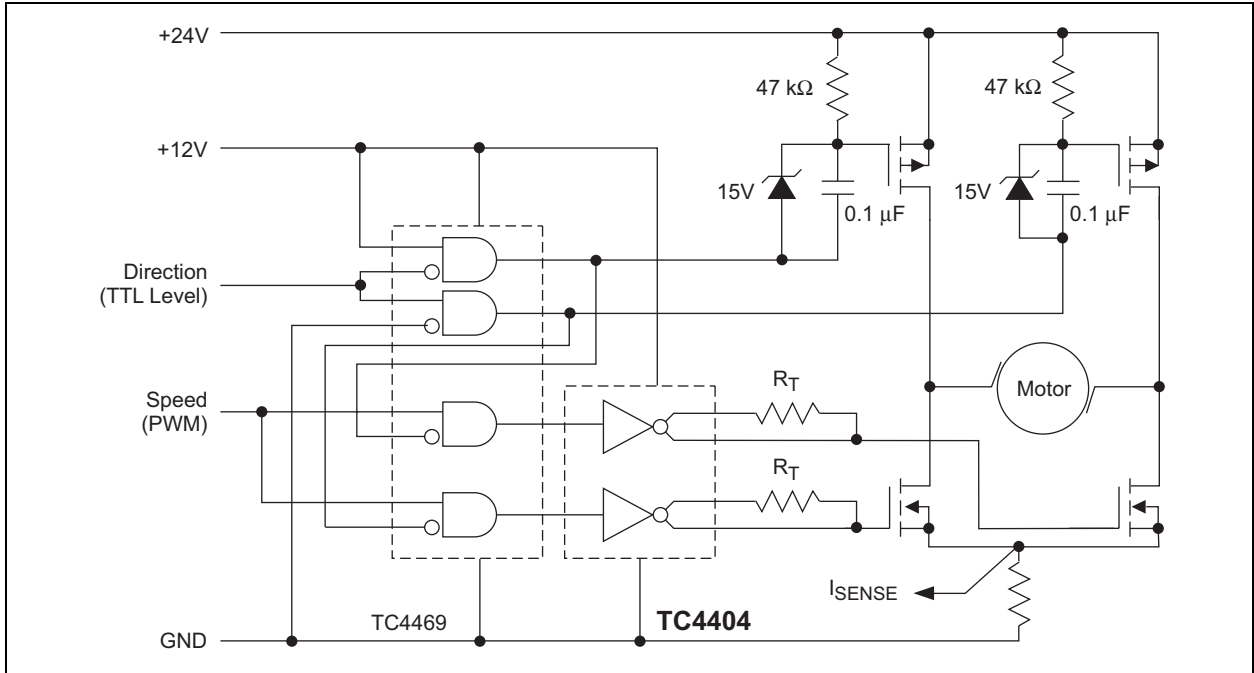

FIGURE 3-4: Servo Motor Control

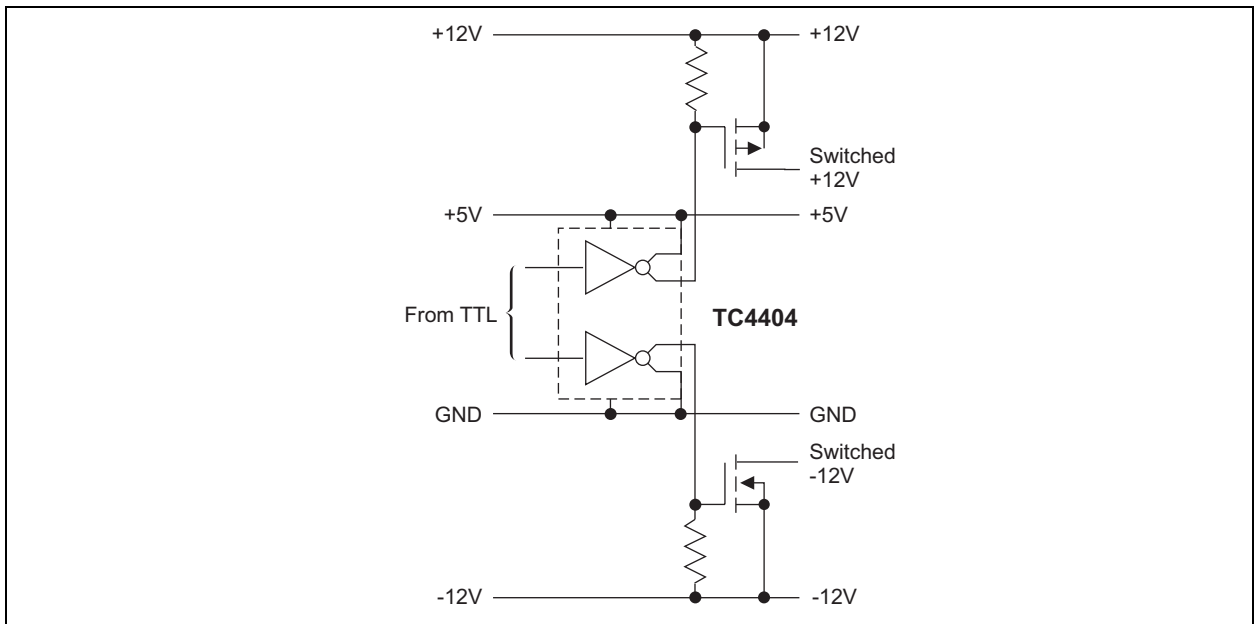
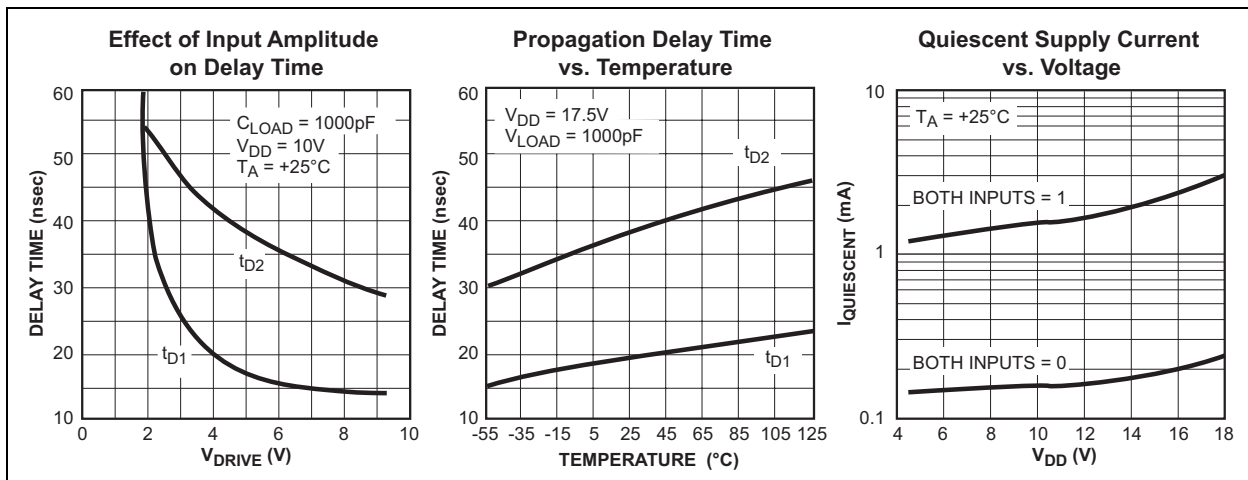
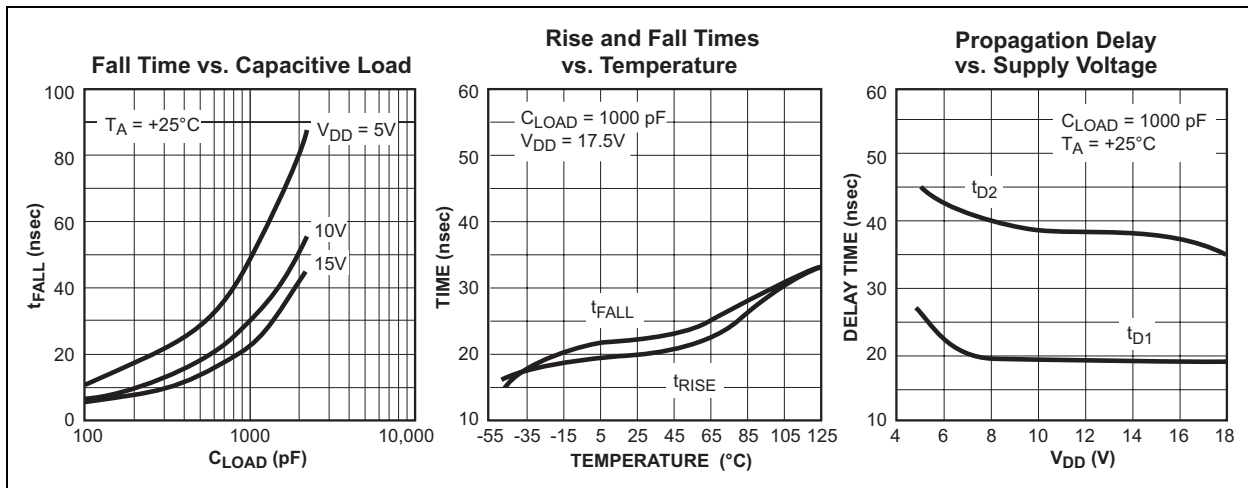
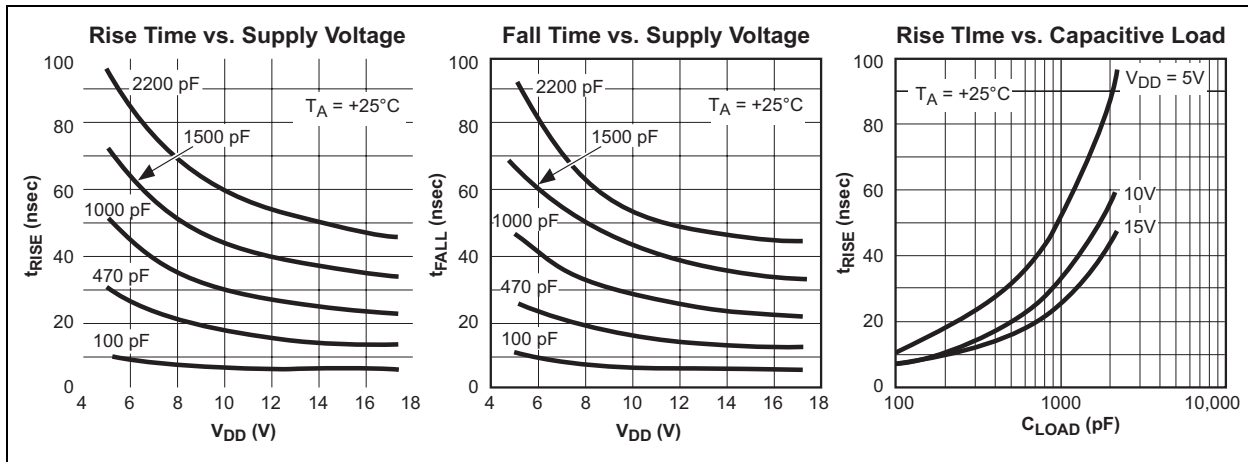

FIGURE 3-5: Reach-Up and Reach-Down Driving

TC4404/TC4405

4.0 TYPICAL CHARACTERISTICS

Note: The graphs and tables provided following this note are a statistical summary based on a limited number of samples and are provided for informational purposes only. The performance characteristics listed herein are not tested or guaranteed. In some graphs or tables, the data presented may be outside the specified operating range (e.g., outside specified power supply range) and therefore outside the warranted range.



TYPICAL CHARACTERISTICS (CONTINUED)

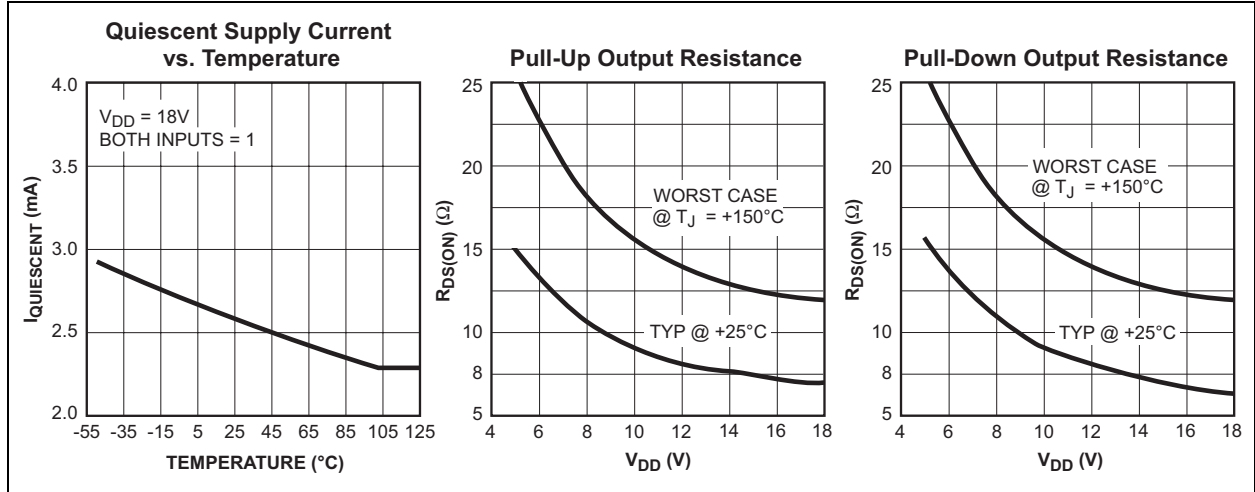

TC4404/TC4405

5.0 PACKAGING INFORMATION

5.1 Package Marking Information

Package marking data not available at this time.

5.2 Taping Form

Component Taping Orientation for 8-Pin SOIC (Narrow) Devices

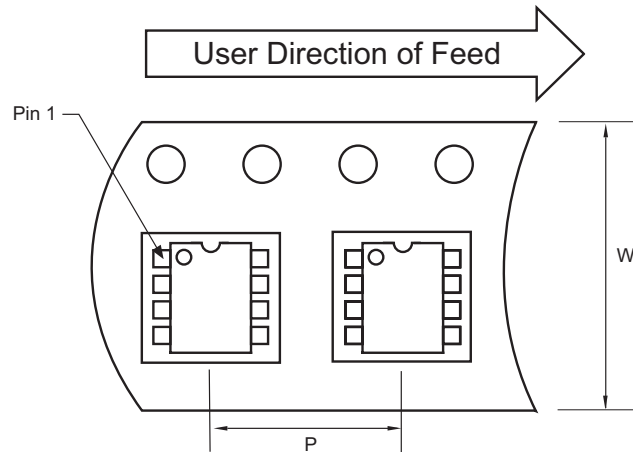

Standard Reel Component Orientation
for 713 Suffix Device

Carrier Tape, Number of Components Per Reel and Reel Size

Package	Carrier Width (W)	Pitch (P)	Part Per Full Reel	Reel Size
8-Pin SOIC (N)	12 mm	8 mm	2500	13 in

5.3 Package Dimensions

8-Pin Plastic DIP

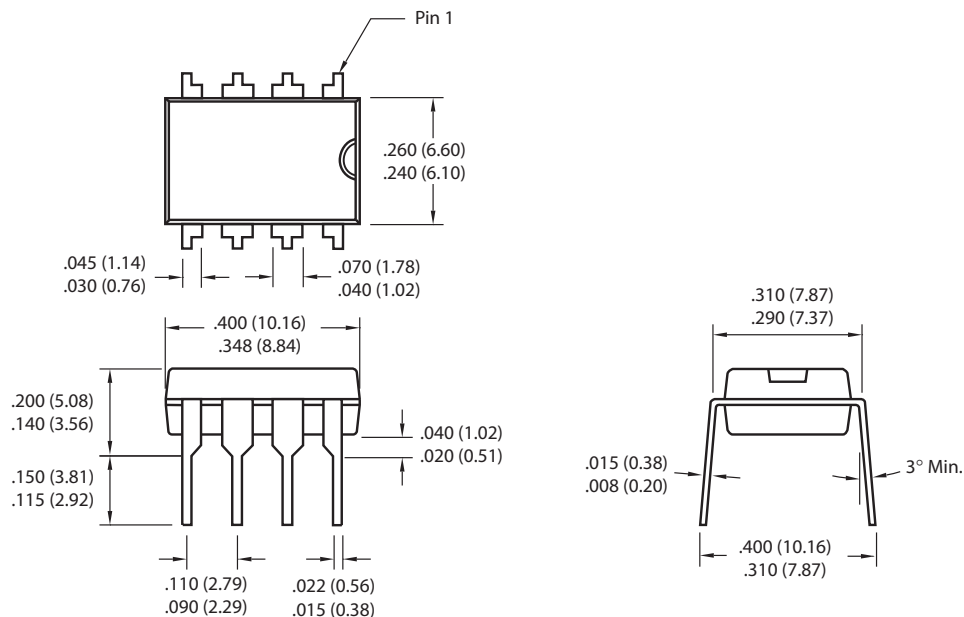

Dimensions: inches (mm)

Package Dimensions (Continued)

8-Pin Cerdip (Narrow)

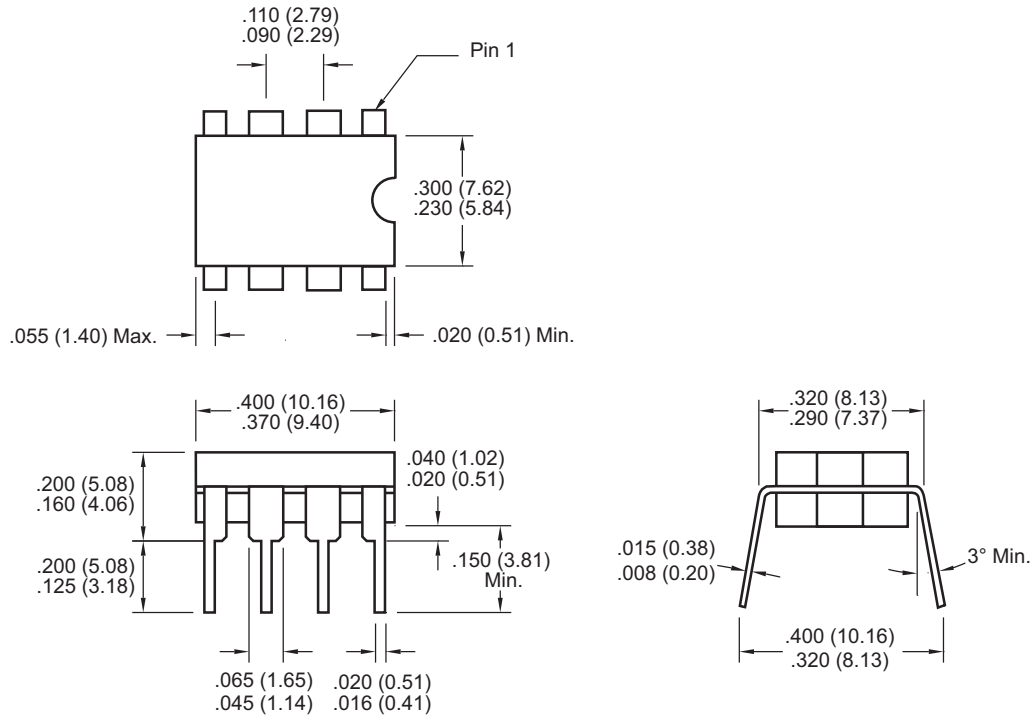

Dimensions: inches (mm)

8-Pin SOIC

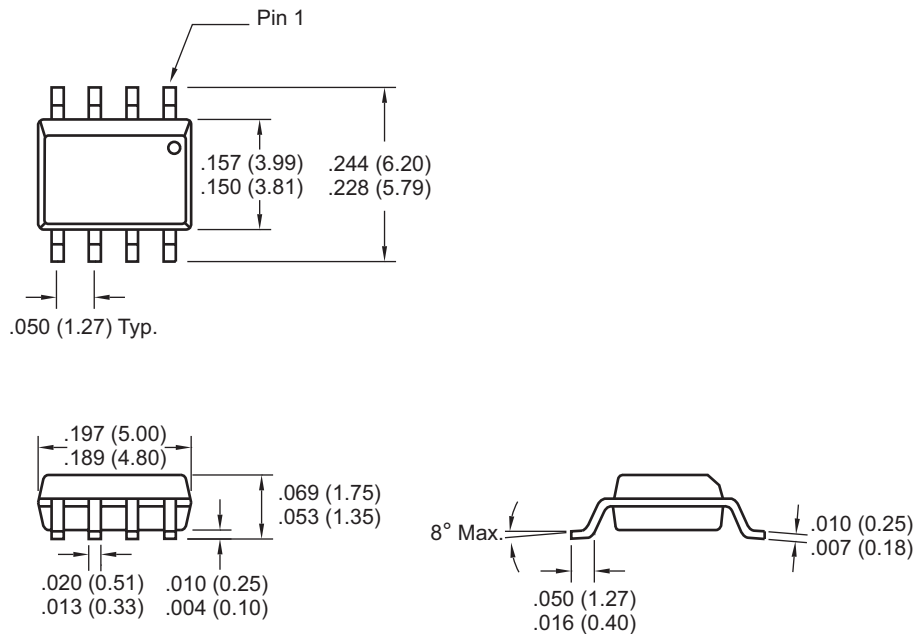

Dimensions: inches (mm)

TC4404/TC4405

NOTES:

THE MICROCHIP WEB SITE

Microchip provides online support via our WWW site at www.microchip.com. This web site is used as a means to make files and information easily available to customers. Accessible by using your favorite Internet browser, the web site contains the following information:

- **Product Support** – Data sheets and errata, application notes and sample programs, design resources, user's guides and hardware support documents, latest software releases and archived software
- **General Technical Support** – Frequently Asked Questions (FAQ), technical support requests, online discussion groups, Microchip consultant program member listing
- **Business of Microchip** – Product selector and ordering guides, latest Microchip press releases, listing of seminars and events, listings of Microchip sales offices, distributors and factory representatives

CUSTOMER CHANGE NOTIFICATION SERVICE

Microchip's customer notification service helps keep customers current on Microchip products. Subscribers will receive e-mail notification whenever there are changes, updates, revisions or errata related to a specified product family or development tool of interest.

To register, access the Microchip web site at www.microchip.com, click on Customer Change Notification and follow the registration instructions.

CUSTOMER SUPPORT

Users of Microchip products can receive assistance through several channels:

- Distributor or Representative
- Local Sales Office
- Field Application Engineer (FAE)
- Technical Support
- Development Systems Information Line

Customers should contact their distributor, representative or field application engineer (FAE) for support. Local sales offices are also available to help customers. A listing of sales offices and locations is included in the back of this document.

Technical support is available through the web site at: <http://support.microchip.com>

TC4404/TC4405

READER RESPONSE

It is our intention to provide you with the best documentation possible to ensure successful use of your Microchip product. If you wish to provide your comments on organization, clarity, subject matter, and ways in which our documentation can better serve you, please FAX your comments to the Technical Publications Manager at (480) 792-4150.

Please list the following information, and use this outline to provide us with your comments about this document.

To: Technical Publications Manager
RE: Reader Response
From: Name _____
Company _____
Address _____
City / State / ZIP / Country _____
Telephone: (_____) _____ - _____ FAX: (_____) _____ - _____

Application (optional):

Would you like a reply? ___Y ___N

Device: TC4404/TC4405 Literature Number: DS21418C

Questions:

1. What are the best features of this document?

2. How does this document meet your hardware and software development needs?

3. Do you find the organization of this document easy to follow? If not, why?

4. What additions to the document do you think would enhance the structure and subject?

5. What deletions from the document could be made without affecting the overall usefulness?

6. Is there any incorrect or misleading information (what and where)?

7. How would you improve this document?

Note the following details of the code protection feature on Microchip devices:

- Microchip products meet the specification contained in their particular Microchip Data Sheet.
- Microchip believes that its family of products is one of the most secure families of its kind on the market today, when used in the intended manner and under normal conditions.
- There are dishonest and possibly illegal methods used to breach the code protection feature. All of these methods, to our knowledge, require using the Microchip products in a manner outside the operating specifications contained in Microchip's Data Sheets. Most likely, the person doing so is engaged in theft of intellectual property.
- Microchip is willing to work with the customer who is concerned about the integrity of their code.
- Neither Microchip nor any other semiconductor manufacturer can guarantee the security of their code. Code protection does not mean that we are guaranteeing the product as "unbreakable."

Code protection is constantly evolving. We at Microchip are committed to continuously improving the code protection features of our products. Attempts to break Microchip's code protection feature may be a violation of the Digital Millennium Copyright Act. If such acts allow unauthorized access to your software or other copyrighted work, you may have a right to sue for relief under that Act.

Information contained in this publication regarding device applications and the like is provided only for your convenience and may be superseded by updates. It is your responsibility to ensure that your application meets with your specifications. MICROCHIP MAKES NO REPRESENTATIONS OR WARRANTIES OF ANY KIND WHETHER EXPRESS OR IMPLIED, WRITTEN OR ORAL, STATUTORY OR OTHERWISE, RELATED TO THE INFORMATION, INCLUDING BUT NOT LIMITED TO ITS CONDITION, QUALITY, PERFORMANCE, MERCHANTABILITY OR FITNESS FOR PURPOSE. Microchip disclaims all liability arising from this information and its use. Use of Microchip devices in life support and/or safety applications is entirely at the buyer's risk, and the buyer agrees to defend, indemnify and hold harmless Microchip from any and all damages, claims, suits, or expenses resulting from such use. No licenses are conveyed, implicitly or otherwise, under any Microchip intellectual property rights.

Trademarks

The Microchip name and logo, the Microchip logo, Accuron, dsPIC, KEELOQ, microID, MPLAB, PIC, PICmicro, PICSTART, PRO MATE, PowerSmart, rfPIC, and SmartShunt are registered trademarks of Microchip Technology Incorporated in the U.S.A. and other countries.

AmpLab, FilterLab, Migratable Memory, MXDEV, MXLAB, SEEVAL, SmartSensor and The Embedded Control Solutions Company are registered trademarks of Microchip Technology Incorporated in the U.S.A.

Analog-for-the-Digital Age, Application Maestro, dsPICDEM, dsPICDEM.net, dsPICworks, ECAN, ECONOMONITOR, FanSense, FlexROM, fuzzyLAB, In-Circuit Serial Programming, ICSP, ICEPIC, Linear Active Thermistor, Mindi, MiWi, MPASM, MPLIB, MPLINK, PICkit, PICDEM, PICDEM.net, PICLAB, PICtail, PowerCal, PowerInfo, PowerMate, PowerTool, REAL ICE, rLAB, rfPICDEM, Select Mode, Smart Serial, SmartTel, Total Endurance, UNI/O, WiperLock and ZENA are trademarks of Microchip Technology Incorporated in the U.S.A. and other countries.

SQTP is a service mark of Microchip Technology Incorporated in the U.S.A.

All other trademarks mentioned herein are property of their respective companies.

© 2006, Microchip Technology Incorporated, Printed in the U.S.A., All Rights Reserved.

 Printed on recycled paper.

QUALITY MANAGEMENT SYSTEM
CERTIFIED BY DNV
== ISO/TS 16949:2002 ==

Microchip received ISO/TS-16949:2002 certification for its worldwide headquarters, design and wafer fabrication facilities in Chandler and Tempe, Arizona, Gresham, Oregon and Mountain View, California. The Company's quality system processes and procedures are for its PICmicro® 8-bit MCUs, KEELOQ® code hopping devices, Serial EEPROMs, microperipherals, nonvolatile memory and analog products. In addition, Microchip's quality system for the design and manufacture of development systems is ISO 9001:2000 certified.



WORLDWIDE SALES AND SERVICE

AMERICAS

Corporate Office
2355 West Chandler Blvd.
Chandler, AZ 85224-6199
Tel: 480-792-7200
Fax: 480-792-7277
Technical Support:
<http://support.microchip.com>
Web Address:
www.microchip.com

Atlanta
Alpharetta, GA
Tel: 770-640-0034
Fax: 770-640-0307

Boston
Westborough, MA
Tel: 774-760-0087
Fax: 774-760-0088

Chicago
Itasca, IL
Tel: 630-285-0071
Fax: 630-285-0075

Dallas
Addison, TX
Tel: 972-818-7423
Fax: 972-818-2924

Detroit
Farmington Hills, MI
Tel: 248-538-2250
Fax: 248-538-2260

Kokomo
Kokomo, IN
Tel: 765-864-8360
Fax: 765-864-8387

Los Angeles
Mission Viejo, CA
Tel: 949-462-9523
Fax: 949-462-9608

San Jose
Mountain View, CA
Tel: 650-215-1444
Fax: 650-961-0286

Toronto
Mississauga, Ontario,
Canada
Tel: 905-673-0699
Fax: 905-673-6509

ASIA/PACIFIC

Australia - Sydney
Tel: 61-2-9868-6733
Fax: 61-2-9868-6755

China - Beijing
Tel: 86-10-8528-2100
Fax: 86-10-8528-2104

China - Chengdu
Tel: 86-28-8676-6200
Fax: 86-28-8676-6599

China - Fuzhou
Tel: 86-591-8750-3506
Fax: 86-591-8750-3521

China - Hong Kong SAR
Tel: 852-2401-1200
Fax: 852-2401-3431

China - Qingdao
Tel: 86-532-8502-7355
Fax: 86-532-8502-7205

China - Shanghai
Tel: 86-21-5407-5533
Fax: 86-21-5407-5066

China - Shenyang
Tel: 86-24-2334-2829
Fax: 86-24-2334-2393

China - Shenzhen
Tel: 86-755-8203-2660
Fax: 86-755-8203-1760

China - Shunde
Tel: 86-757-2839-5507
Fax: 86-757-2839-5571

China - Wuhan
Tel: 86-27-5980-5300
Fax: 86-27-5980-5118

China - Xian
Tel: 86-29-8833-7250
Fax: 86-29-8833-7256

ASIA/PACIFIC

India - Bangalore
Tel: 91-80-4182-8400
Fax: 91-80-4182-8422

India - New Delhi
Tel: 91-11-5160-8631
Fax: 91-11-5160-8632

India - Pune
Tel: 91-20-2566-1512
Fax: 91-20-2566-1513

Japan - Yokohama
Tel: 81-45-471-6166
Fax: 81-45-471-6122

Korea - Gumi
Tel: 82-54-473-4301
Fax: 82-54-473-4302

Korea - Seoul
Tel: 82-2-554-7200
Fax: 82-2-558-5932 or
82-2-558-5934

Malaysia - Penang
Tel: 60-4-646-8870
Fax: 60-4-646-5086

Philippines - Manila
Tel: 63-2-634-9065
Fax: 63-2-634-9069

Singapore
Tel: 65-6334-8870
Fax: 65-6334-8850

Taiwan - Hsin Chu
Tel: 886-3-572-9526
Fax: 886-3-572-6459

Taiwan - Kaohsiung
Tel: 886-7-536-4818
Fax: 886-7-536-4803

Taiwan - Taipei
Tel: 886-2-2500-6610
Fax: 886-2-2508-0102

Thailand - Bangkok
Tel: 66-2-694-1351
Fax: 66-2-694-1350

EUROPE

Austria - Wels
Tel: 43-7242-2244-399
Fax: 43-7242-2244-393

Denmark - Copenhagen
Tel: 45-4450-2828
Fax: 45-4485-2829

France - Paris
Tel: 33-1-69-53-63-20
Fax: 33-1-69-30-90-79

Germany - Munich
Tel: 49-89-627-144-0
Fax: 49-89-627-144-44

Italy - Milan
Tel: 39-0331-742611
Fax: 39-0331-466781

Netherlands - Drunen
Tel: 31-416-690399
Fax: 31-416-690340

Spain - Madrid
Tel: 34-91-708-08-90
Fax: 34-91-708-08-91

UK - Wokingham
Tel: 44-118-921-5869
Fax: 44-118-921-5820