

ICB1FL02G

Smart Ballast Control IC for Fluorescent Lamp Ballasts

Power Management & Supply



Never stop thinking

ICB1FL02G

Revision History: **2008-09** V 2.1

Previous Version: 2005-06-06 (ICB1FL01G)

Page	Subjects (major changes since last revision)
19	Min Duration of EOL1
25	Preheating Time updated
26	EOL Current Threshold, AC & DC

Previous Version: 2006-02-08 (ICB1FL02G)

3	Package PG-DSO-18-2, halogen-free mould compound, WEEE compliant
11	Function removed and sentence deleted "During ignition and prerun mode the notch filter is bypassed."
18	State diagram reworked (frequency range description corrected)
23	PFC zero current detector: clamping of positive voltages
24	PFC section: initial on-time and repetition time adapted
25	Inverter control: minimum duration of fault conditions EOL1, Cap Load 2 adapted
26	Restart after lamp removal: discharge resistor value adapted
33	LC equations corrected

Edition 2008-09

Published by
Infineon Technologies AG
81726 Munich, Germany

© 10/16/08 Infineon Technologies AG
All Rights Reserved.

Legal Disclaimer

The information given in this document shall in no event be regarded as a guarantee of conditions or characteristics. With respect to any examples or hints given herein, any typical values stated herein and/or any information regarding the application of the device, Infineon Technologies hereby disclaims any and all warranties and liabilities of any kind, including without limitation, warranties of non-infringement of intellectual property rights of any third party.

Information

For further information on technology, delivery terms and conditions and prices, please contact the nearest Infineon Technologies Office (www.infineon.com).

Warnings

Due to technical requirements, components may contain dangerous substances. For information on the types in question, please contact the nearest Infineon Technologies Office.

Infineon Technologies components may be used in life-support devices or systems only with the express written approval of Infineon Technologies, if a failure of such components can reasonably be expected to cause the failure of that life-support device or system or to affect the safety or effectiveness of that device or system. Life support devices or systems are intended to be implanted in the human body or to support and/or maintain and sustain and/or protect human life. If they fail, it is reasonable to assume that the health of the user or other persons may be endangered.

Smart Ballast Control IC for Fluorescent Lamp Ballasts

Product Highlights

- Lowest Count of external Components
- HV-Driver with coreless Transformer Technology
- Improved Reliability and minimized Spread due to digital and optimized analog control functions

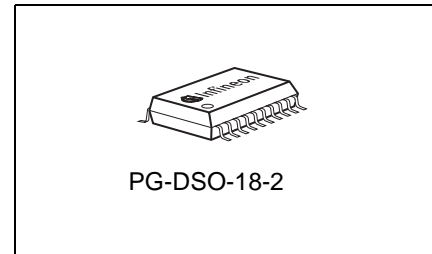

Features PFC

- Discontinuous Conduction Mode PFC
- Integrated Compensation of PFC Control Loop
- Adjustable PFC Current Limitation
- Adjustable PFC Bus Voltage

Features Lamp Ballast Inverter

- Supports Restart after Lamp Removal and End-of-Life Detection in Multi-Lamp Topologies
- End-of-Life (EOL) detected by adjustable \pm Thresholds of sensed lamp voltage
- Rectifier Effect detected by ratio of \pm Amplitude of Lamp Voltage
- Detection of different capacitive Mode Operations
- Adjustable Inverter Overcurrent Shutdown
- Self-adaption of Ignition Time from 40ms to 235ms
- Parameters adjustable by Resistors only
- Pb-free lead plating; RoHS compliant
- Halogen-free mould compound, WEEE compliant

Description

The Smart Ballast IC is designed to control a Fluorescent Lamp Ballast including a Discontinuous Conduction Mode Power Factor Correction (PFC), a lamp Inverter Control and a High Voltage Level Shift Half-Bridge Driver.

The application requires a minimum of external components. There are integrated low pass filters and an internal compensation for the PFC voltage loop control. Preheating time is adjustable by a single resistor only in the range between 0 and 2000ms. In the same way the preheating frequency and run frequency are set by resistors only. The control concept covers requirements for T5 lamp ballasts such as detection of end-of-life and detection of capacitive mode operation and other protection measures even in multilamp topologies.

ICB1FL02G is easy to use and easy to design and therefore a basis for a cost effective solution for fluorescent lamp ballasts.

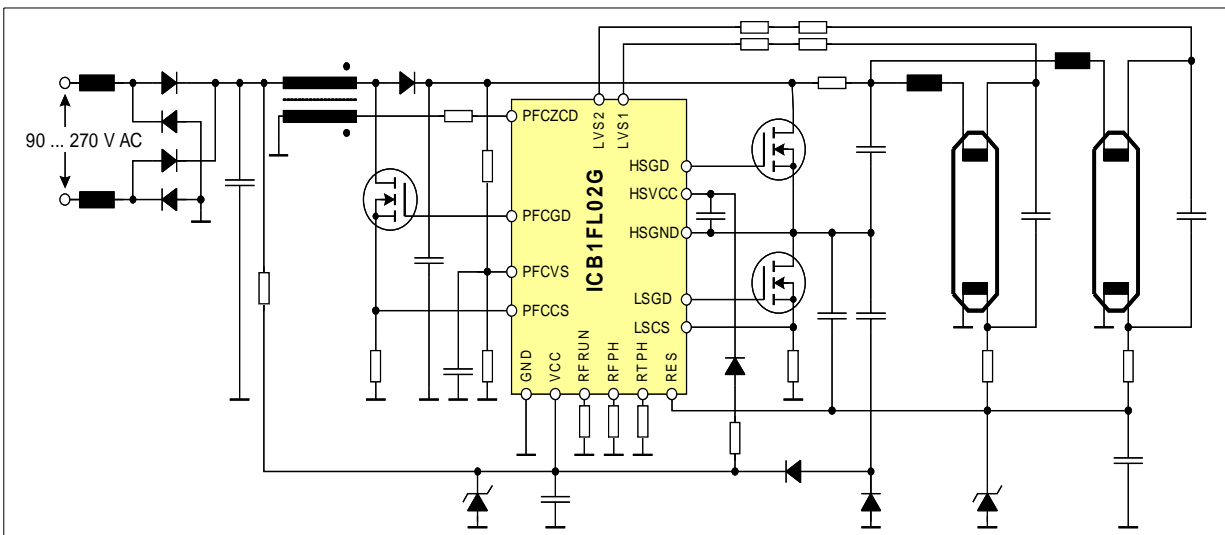

Type	Package
ICB1FL02G	PG-DSO-18-2

Table of Contents		Page
1	Pin Configuration and Description	5
1.1	Pin Configuration PG-DSO-18-1	5
1.2	Pin Description	5
2	Block Diagram	8
3	Functional Description	9
3.1	Typical operating levels during start-up	9
3.2	PFC Preconverter	11
3.3	Typical operating levels during start-up	13
3.4	Detection of End-of-Life and Rectifier Effect	14
3.5	Detection of capacitive mode operating conditions	15
3.6	Interruption of Operation and Restart after Lamp Removal	16
4	State Diagram	18
5	Protection Functions	19
6	Electrical Characteristics	20
6.1	Absolute Maximum Ratings	20
6.2	Operating Range	21
6.3	Characteristics	22
6.3.1	Power Supply Section	22
6.3.2	PFC Section	23
6.3.2.1	PFC Current Sense (PFCCS)	23
6.3.2.2	PFC Zero Current Detector (PFCZCD)	23
6.3.2.3	PFC Bus Voltage Sense (PFCVS)	23
6.3.2.4	PFC PWM Generation	24
6.3.2.5	PFC Gate Drive (PFCGD)	24
6.3.3	Inverter Section	25
6.3.3.1	Inverter Control (RFRUN, RFPH, RTPH)	25
6.3.3.2	Inverter Low Side Current Sense (LSCS)	25
6.3.3.3	Restart after Lamp Removal (RES)	26
6.3.3.4	Lamp Voltage Sense (LVS1, LVS2)	26
6.3.3.5	Inverter Low Side Gate Drive (LSGD)	27
6.3.3.6	Inverter High Side Gate Drive (HSGD)	28
7	Application Examples	29
7.1	Operating Behaviour of a Ballast for a single Fluorescent Lamp	29
7.2	Design Equations of a Ballast Application	30
7.3	Multilamp Ballast Topologies	35
8	Package Outlines	36

1 Pin Configuration and Description

1.1 Pin Configuration PG-DSO-18-1

Pin	Symbol	Function
1	LSCS	Low side current sense (inverter)
2	LSGD	Low side gate drive (inverter)
3	VCC	Supply voltage
4	GND	Controller ground
5	PFCGD	PFC gate drive
6	PFCCS	PFC current sense
7	PFCZCD	PFC zero current detector
8	PFCVS	PFC voltage sense
9	RFRUN	Set R for run frequency
10	RFPH	Set R for preheating frequency
11	RTPH	Set R for preheating time
12	RES	Restart after lamp removal
13	LVS1	Lamp voltage sense 1
14	LVS2	Lamp voltage sense 2
15	n.e.	Not existing
16	n.e.	Not existing
17	HSGND	High side ground
18	HSVCC	High side supply voltage
19	HSGD	High side gate drive
20	HSGND	High side ground

1.2 Pin Description

LSCS (Low side current sense, Pin 1)

This pin is directly connected to the shunt resistor which is located between the Source terminal of the low-side MOSFET of the inverter and ground.

Internal clamping structures and filtering measures allow for sensing the Source current of the low-side inverter MOSFET without additional filter components. There is a first threshold of 0,8V, which provides a couple of increasing steps of frequency during ignition mode, if exceeded by the sensed current signal for a time longer than 250ns. If the sensed current signal exceeds a second threshold of 1,6V for longer than 400ns during all operating modes, a latched shut down of the IC will be the result.

LSGD (Low side gate drive, Pin 2)

The Gate of the low-side MOSFET in a half-bridge inverter topology is controlled by this pin. There is an active L-level during UVLO (undervoltage lockout) and a limitation of the max. H-level at 11V during normal operation. Turning on the MOSFET softly (with reduced di_{DRAIN}/dt), the Gate drive voltage rises within 220ns from L-level to H-level. The fall time of the Gate drive voltage is less than 50ns in order to turn off quickly. This measure produces different switching speeds during turn-on and turn-off as it is usually achieved with a diode in parallel to a resistor in the Gate drive loop. It is recommended to use a resistor of about 150Ohm between drive pin and Gate in order to avoid oscillations and in order to shift the power dissipation of discharging the Gate capacitance into this resistor. The dead time between LSGD signal and HSGD signal is 1800ns typically.

VCC (Supply voltage, Pin 3)

This pin provides the power supply of the ground related section of the IC. There is a turn-on threshold at 14V and an UVLO threshold at 10,5V. Upper supply voltage level is 17,5V. There is an internal zener diode clamping Vcc at 16V (2mA typically). The zener current is internally limited to 5mA max. For higher current levels an external zener diode is required. Current consumption during UVLO and during fault mode is less than 150µA. A ceramic capacitor close to the supply and GND pin is required in order to act as a low-impedance power source for Gate drive and logic signal currents.

GND (Ground, Pin 4)

This pin is connected to ground and represents the ground level of the IC for supply voltage, Gate drive and sense signals.

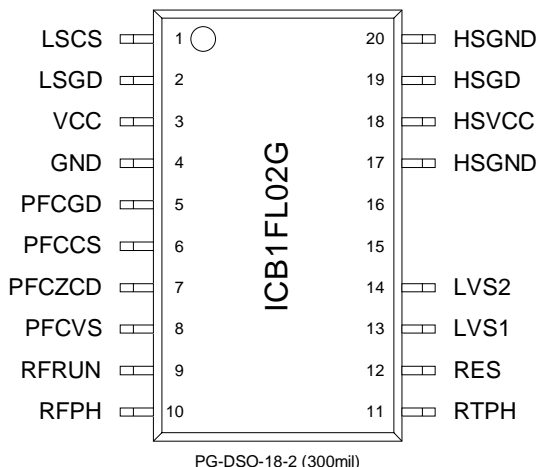

Pin Configuration and Description

PFCGD (PFC gate drive, Pin 5)

The Gate of the MOSFET in the PFC preconverter designed in boost topology is controlled by this pin. There is an active L-level during UVLO and a limitation of the max. H-level at 11V during normal operation. Turning on the MOSFET softly (with a reduced di_{DRAIN}/dt), the Gate drive voltage rises within 220ns from L-level to H-level. The fall time of the Gate voltage is less than 50ns in order to turn off quickly. A resistor of about 100Ω between drive pin and Gate in order to avoid oscillations and in order to shift the power dissipation of discharging the Gate capacitance into this resistor is recommended.

The PFC section of the IC controls a boost converter as a PFC preconverter in discontinuous conduction mode (DCM). Typically the control starts with Gate drive pulses with an on-time of 1μs increasing up to 24μs and a off-time of 40μs. As soon as a sufficient ZCD (zero current detector) signal is available, the operating mode changes from a fixed frequent operation to an operation with variable frequency. During rated and medium load conditions we get an operation with critical conduction mode (CritCM), that means triangular shaped currents in the boost converter choke without gaps when reaching the zero level and variable operating frequency. During light load (detected by the internal error amplifier) we get an operation with discontinuous conduction mode (DCM), that means triangular shaped currents in the boost converter choke with gaps when reaching the zero level and variable operating frequency in order to avoid steps in the consumed line current.

PFCCS (PFC current sense, Pin 6)

The voltage drop across a shunt resistor located between Source of the PFC MOSFET and GND is sensed with this pin. If the level exceeds a threshold of 1V for longer than 260ns the PFC Gate drive is turned off as long as the ZCD (zero current detector) enables a new cycle. If there is no ZCD signal available within 40μs after turn-off of the PFC Gate drive, a new cycle is initiated from an internal start-up timer.

PFCZCD (PFC zero current detection, Pin 7)

This pin senses the point of time when the current through the boost inductor becomes zero during off-time of the PFC MOSFET in order to initiate a new cycle. The moment of interest appears when the voltage of the separate ZCD winding changes from positive to negative level which represents a voltage of zero at the inductor windings and therefore the end of current flow from lower input voltage level to higher output voltage level. There is a threshold with hysteresis, for increasing voltage a level of 1,5V, for decreasing voltage a level of 0,5V, that detects the change of inductor voltage. A resistor connected between ZCD winding and sense input limits the sink

and source current of the sense pin, when the voltage of the ZCD winding exceeds the internal clamping levels (6,3V and -2,9V @ 4mA) of the IC.

If the sensed level of the ZCD winding is not sufficient (e.g. during start-up), an internal start-up timer will initiate a new cycle every 40μs after turn-off of the PFC Gate drive.

PFCVS (PFC voltage sense, Pin 8)

The intermediate circuit voltage (bus voltage) at the smoothing capacitor is sensed by a resistive divider at this pin. The internal reference voltage for rated bus voltage is 2,5V. There are further thresholds at 0,375V (15% of rated bus voltage), 1,83V (73% of rated bus voltage) and 2,725V (109% of rated bus voltage) for detecting open control loop, undervoltage and overvoltage.

FRUN (Set R for run frequency, Pin 9)

A resistor from this pin to ground sets the operating frequency of the inverter during run mode. Typical run frequency range is 20kHz to 100kHz. The set resistor R_{RFRUN} can be calculated based on the run frequency f_{RUN} according to the equation

$$R_{RFRUN} = \frac{5 \cdot 10^8 \Omega \text{Hz}}{f_{RUN}}$$

FRPH (Set R for preheating frequency, Pin 10)

A resistor from this pin to ground sets together with the resistor at pin 9 the operating frequency of the inverter during preheat mode. Typical preheat frequency range is run frequency (as a minimum) to 150kHz. The set resistor R_{RFPH} can be calculated based on the preheat frequency f_{PH} and the resistor R_{RFRUN} according to the equation:

$$R_{RFPH} = \frac{R_{RFRUN}}{\frac{f_{PH} \cdot R_{RFRUN}}{5 \cdot 10^8 \Omega \text{Hz}} - 1}$$

The total value of both resistors R_{RFPH} and R_{RFRUN} switched in parallel should not be less than 3,3kΩ.

RTPH (Set R for preheating time, Pin 11)

A resistor from this pin to ground sets the preheating time of the inverter during preheat mode. A set resistor range from zero to 18kΩ corresponds to a range of preheating time from zero to 2000ms subdivided in 127 steps.

RES (Restart after lamp removal, Pin 12)

A source current out of this pin via resistor and filament to ground monitors the existence of the low-side filament of the fluorescent lamp for restart after lamp

Pin Configuration and Description

removal. A capacitor from this pin directly to ground eliminates a superimposed AC voltage that is generated as a voltage drop across the low-side filament. With a second sense resistor the filament of a paralleled lamp can be included into the lamp removal sense.

During typical start-up with connected filaments of the lamp a current source I_{RES3} (20 μ A) is active as long as $V_{CC} > 10,5V$ and $V_{RES} < V_{RESC1}$ (1,6V). An open Low-side filament is detected, when $V_{RES} > V_{RESC1}$. Such a condition will prevent the start-up of the IC. In addition the comparator threshold is set to V_{RESC2} (1,3V) and the current source changes to I_{RES4} (17 μ A). Now the system is waiting for a voltage level lower than V_{RESC2} at the RES-Pin that indicates a connected low-side filament, which will enable the start-up of the IC.

An open high-side filament is detected when there is no sink current $I_{LVSSink}$ (15 μ A) into both of the LVS-Pins before the V_{CC} start-up threshold is reached. Under these conditions the current source at the RES-Pin is I_{RES1} (41 μ A) as long as $V_{CC} > 10,5V$ and $V_{RES} < V_{RESC1}$ (1,6V) and the current source is I_{RES2} (34 μ A) when the threshold has changed to V_{RESC2} (1,3V). In this way the detection of the high-side filament is mirrored to the levels on the RES-Pin.

Finally there is a delay function implemented at the RES-Pin. When a fault condition happens e.g. by an end-of-life criteria the inverter is turned-off. In some topologies a transient AC lamp voltage may occur immediately after shut down of the Gate drives which could be interpreted as a lamp removal. In order to generate a delay for the detection of a lamp removal the capacitor at the RES-Pin is charged by the I_{RES3} (20 μ A) current source up to the threshold V_{RESC1} (1,6V) and discharged by an internal resistor $R_{RESdisch}$, which operates in parallel to the external sense resistor at this pin, to the threshold V_{RESC3} (0,375V). The total delay amounts to 32 of these cycles, which corresponds to a delay time between 30ms to 100ms dependent on capacitor value.

In addition this pin is applied to sense capacitive mode operation by use of a further capacitor connected from this pin to the nod of the high-side MOSFET's Source terminal and the low-side MOSFET's Drain terminal. The sense capacitor and the filter capacitor are acting as a capacitive voltage divider that allows for detecting voltage slopes versus timing sequence and therefore indicating capacitive mode operation. A typical ratio of the capacitive divider is 410V/2,2V which results in the capacitor values e.g. of 10nF and 53pF (56pF).

LVS1 (Lamp voltage sense 1, Pin 13)

Before the IC enters the softstart mode this pin has to sense a sink current above 26 μ A (max) which is fed via resistors from the bus voltage across the high-side filament of the fluorescent lamp in order to monitor the existence of the filament for restart after lamp removal. Together with LVS2 (pin 14) and RES (pin 12) the IC can monitor the lamp removal of totally 4 lamps.

During run mode the lamp voltage is sensed by the AC current fed into this pin via resistors. Exceeding one of the two thresholds of either +215 μ A or -215 μ A cycle by cycle for longer than 610 μ s, the interpretation of this event is a failure due to EOL1 (end-of-life). A rectifier effect (EOL2) is assumed if the ratio of the sequence of positive and negative amplitudes is above 1,15 or below 0,85 for longer than 500ms. A failure due to EOL1 or EOL2 changes the operating mode from run mode into a latched fault mode that stops the operation until a reset occurs by lamp removal or by cycle of power.

EOL1 and EOL2 require an AC current with zerocrossings at LVS-Pin for a reliable detection. A DC current at LVS-Pin results in a definite turn-off action acc. to EOL1 only if the sensed current exceeds the threshold $I_{LVSEOLDC} = \pm 175\mu A$ (typically).

If the functionality of this pin is not required (e.g. for single lamp designs) it can be disabled by connecting this pin to ground.

LVS2 (Lamp voltage sense 2, Pin 14)

Same functionality as LVS1 (pin 13) for monitoring a paralleled lamp circuit.

HSGND (High side ground, Pin 17)

This pin is connected to the Source terminal of the high-side MOSFET, which is also the nod of high-side and low-side MOSFET. This pin represents the floating ground level of the high-side driver and high-side supply.

HSVCC (High side supply voltage, Pin 18)

This pin provides the power supply of the high-side ground related section of the IC. An external capacitor between pin 15 and 16 acts like a floating battery which has to be recharged cycle by cycle via high voltage diode from low-side supply voltage during on-time of the low-side MOSFET. There is an UVLO threshold with hysteresis that enables high-side section at 10,1V and disables it at 8,4V.

HSGD (High side gate drive, Pin 19)

The Gate of the high-side MOSFET in a half-bridge inverter topology is controlled by this pin. There is an active L-level during UVLO and a limitation of the max. H-level at 11V during normal operation. The switching characteristics are the same as described for LSGD (pin 2). It is recommended to use a resistor of about 150 Ω between drive pin and Gate in order to avoid oscillations and in order to shift the power dissipation of discharging the Gate capacitance into this resistor.

The dead time between LSGD signal and HSGD signal is 1800ns typically.

HSGND (High side ground, Pin 20)

This pin is internally connected with pin 17.

2 Block Diagram

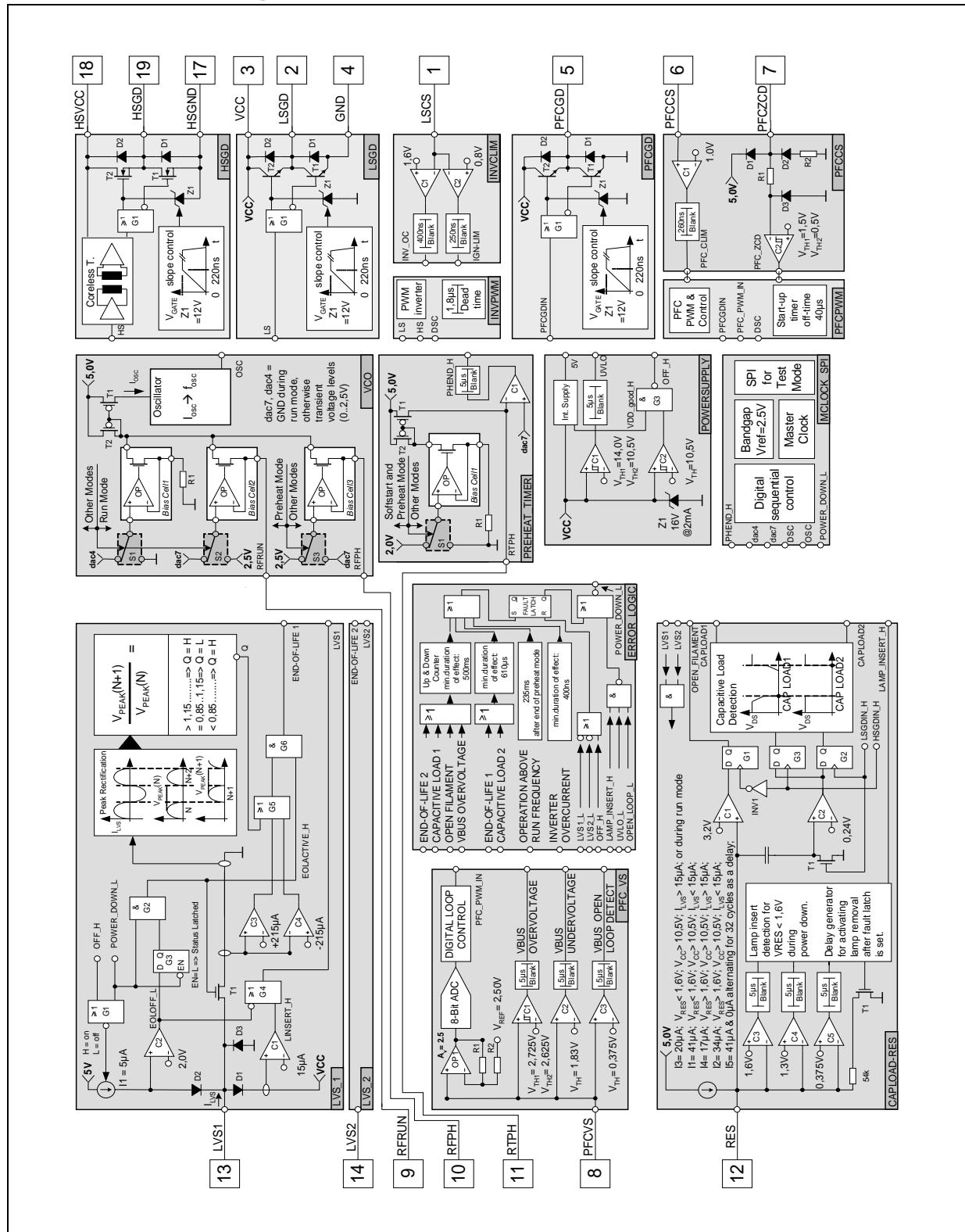

Figure 1 Simplified Block Diagram of ICB1FL02G

3 Functional Description

3.1 Typical operating levels during start-up

The control of the ballast should be able to start the operation within less than 100ms. Therefore the current consumption of the IC is less than 150µA during UVLO. With a small start-up capacitor (about 1µF) and a power supply, that feeds within 100µs (charge pump of the inverter) the IC can cover this feature.

As long as the V_{CC} is less than 10,5V, the current consumption is typically 80µA. Above a V_{CC} voltage level of 10,5V the IC checks whether the lamp(s) are assembled by detecting a current across the filaments. The low-side filament is checked from a source current (20µA typ.) out of pin RES, that produces a voltage drop at the sense resistor, which is connected via low-side filament to ground. An open filament is detected, when the voltage level at pin RES is above 1,6V. The high-side filament (or the high-side of a series topology) is checked by a current (15µA typ.) into the LVS pin. An open high-side filament causes a higher source current (41µA / 34µA typ.) out of pin RES in order to exceed the 1,6V threshold. If one of both filaments is not able to conduct the test current, the control circuit is disabled. The IC is enabled as soon as a sufficient current is detected across the filaments or the supply voltage drops below the UVLO threshold (10,5V) e.g. by turn-off and turn-on of mains switch.

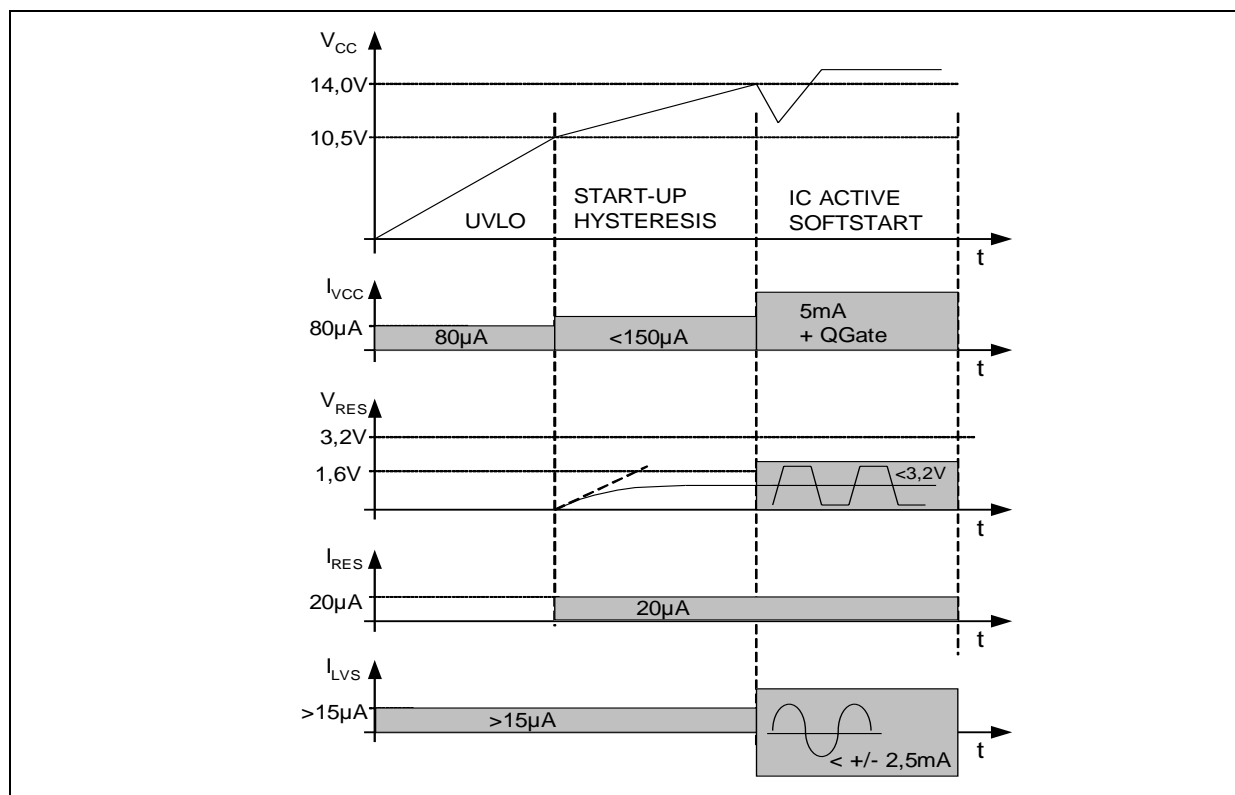

Figure 2 Progress of levels during a typical start-up.

When the previous conditions are fulfilled, and V_{CC} has reached the start-up threshold (14V), there is finally a check of the Bus voltage. If the level is less than 15% of rated Bus voltage, the IC is waiting in power down mode until the voltage increases. If the level is above 109% of rated Bus voltage there is no Gate drive, but an active IC. The supply voltage V_{CC} will fall below the UVLO threshold and a new start-up attempt is initiated.

As soon as start-up conditions are fulfilled the IC starts driving the inverter with the start-up frequency of 125kHz. Now the complete control including timers and the PFC control can be set in action. There are current limitation thresholds for PFC preconverter and ballast inverter equipped with spike filters. The PFC current limitation interrupts the on-time of the PFC MOSFET if the voltage drop at shunt resistor exceeds 1V and restarts after next input from ZCD. The inverter current limitation operates with a first threshold of 0,8V which increases the operating frequency during ignition mode if exceeded. A second threshold is provided at 1,6V that stops the whole control circuit and latches this event as a fault.

Functional Description

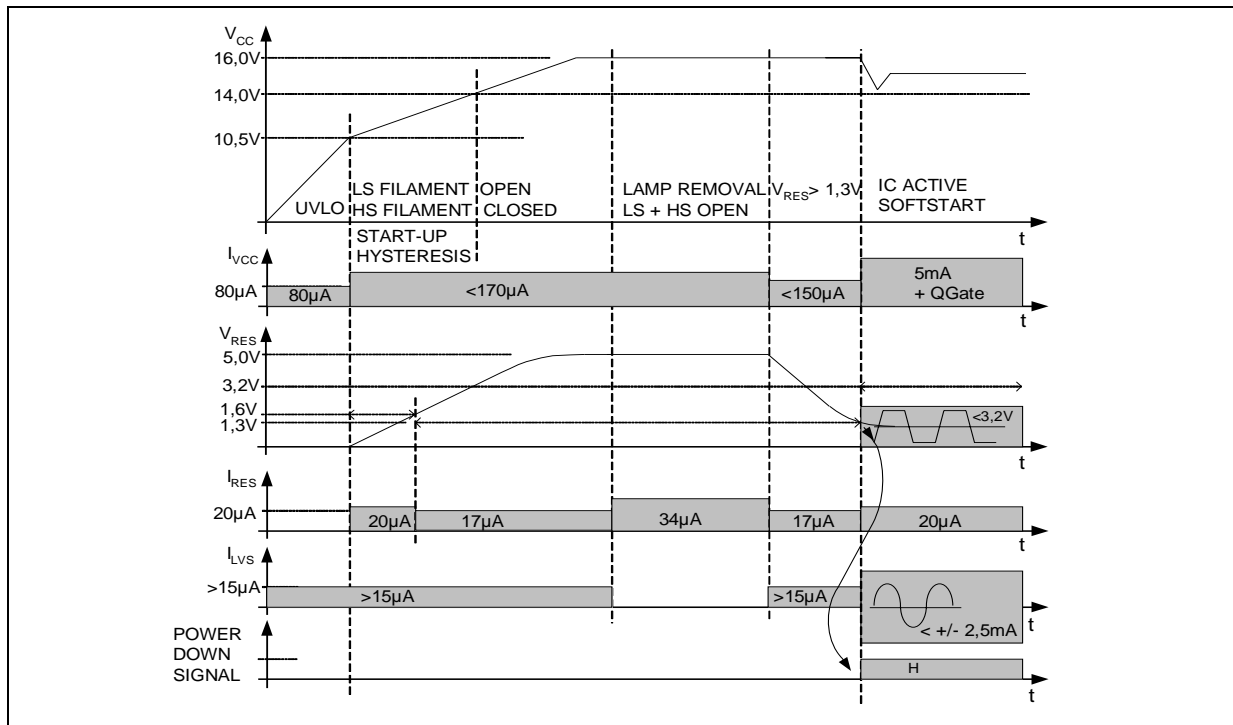

Figure 3 Start-up with LS filament broken and subsequent lamp removal.

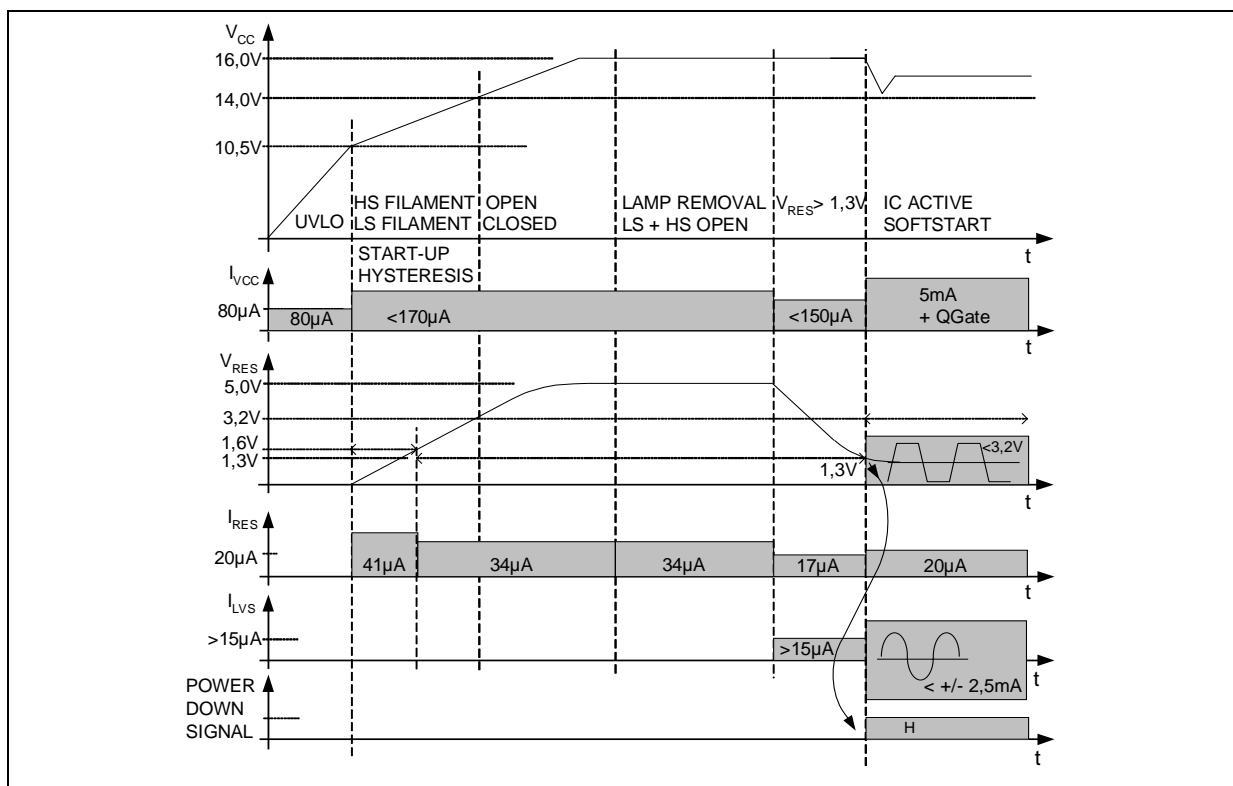

Figure 4 Start-up with HS filament broken and subsequent lamp removal.

3.2 PFC Preconverter

PFC is starting with a fixed frequent operation (ca. 25kHz), beginning with an on-time of 1 μ s and an off-time of 40 μ s. The on-time is enlarged every 400 μ s to a maximum on-time of 23 μ s. The control switches over into critical conduction mode (CritCM) operation as soon as a sufficient ZCD signal is available. There is an overvoltage threshold at 109% of rated Bus voltage that stops PFC Gate drive as long as the Bus voltage has reached a level of 105% of rated Bus voltage again. The compensation of the voltage control loop is completely integrated. The internal reference level of the Bus voltage sense (PFCVS) is 2,5V with high accuracy.

The PFC control operates in CritCM in the range of 23 μ s > on-time > 2,3 μ s. For lower loads the control operates in discontinuous conduction mode (DCM) with an on-time down to 0,5 μ s and an increasing off-time. With this control method the PFC preconverter covers a stable operation from 100% of load to 0,1% .

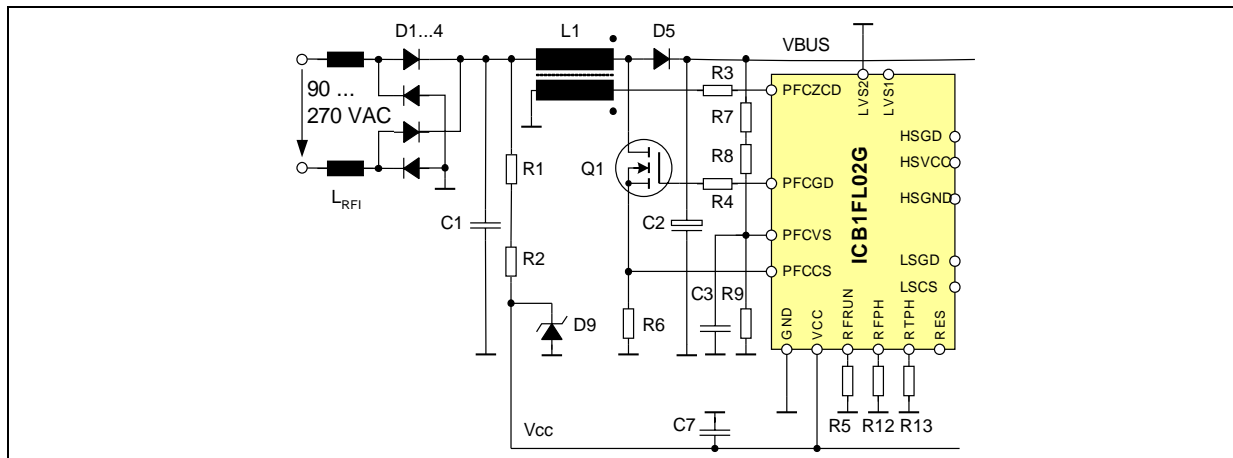

Figure 5 Circuit Diagram of the PFC preconverter section.

Overvoltage, undervoltage and open loop detection at pin PFCVS are sensed by analog comparators. The BUS voltage loop control is provided by a 8bit sigma-delta A/D-Converter with a sampling rate of 400 μ s and a resolution of 4mV/bit. So a range of +/- 0,5V from the reference level of 2,50V is covered. The digital error signal has to pass a digital notch filter in order to suppress the AC voltage ripple of twice of the mains frequency. A subsequent error amplifier with PI characteristic cares for stable operation of the PFC preconverter.

The zero current detection is sensed by a separate pin PFCZCD. The information of finished current flow during demagnetization is required in CritCM and in DCM as well. The input is equipped with a special filtering including a blanking of typically 500ns and is combined with a large hysteresis between the thresholds of typically 0,5V and 1,5V. In case of bad coupling between primary inductor winding and secondary ZCD-winding an additional filtering by a capacitor at ZCD pin might be necessary in order to avoid mistriggerring by long lasting oscillations during switching slopes of the PFC MOSFET.

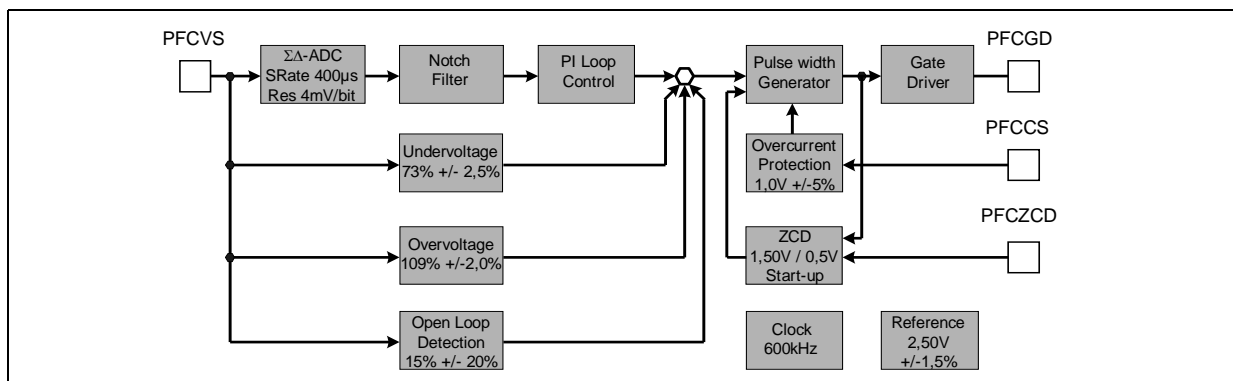

Figure 6 Structure of the mixed digital and analog control of PFC preconverter.

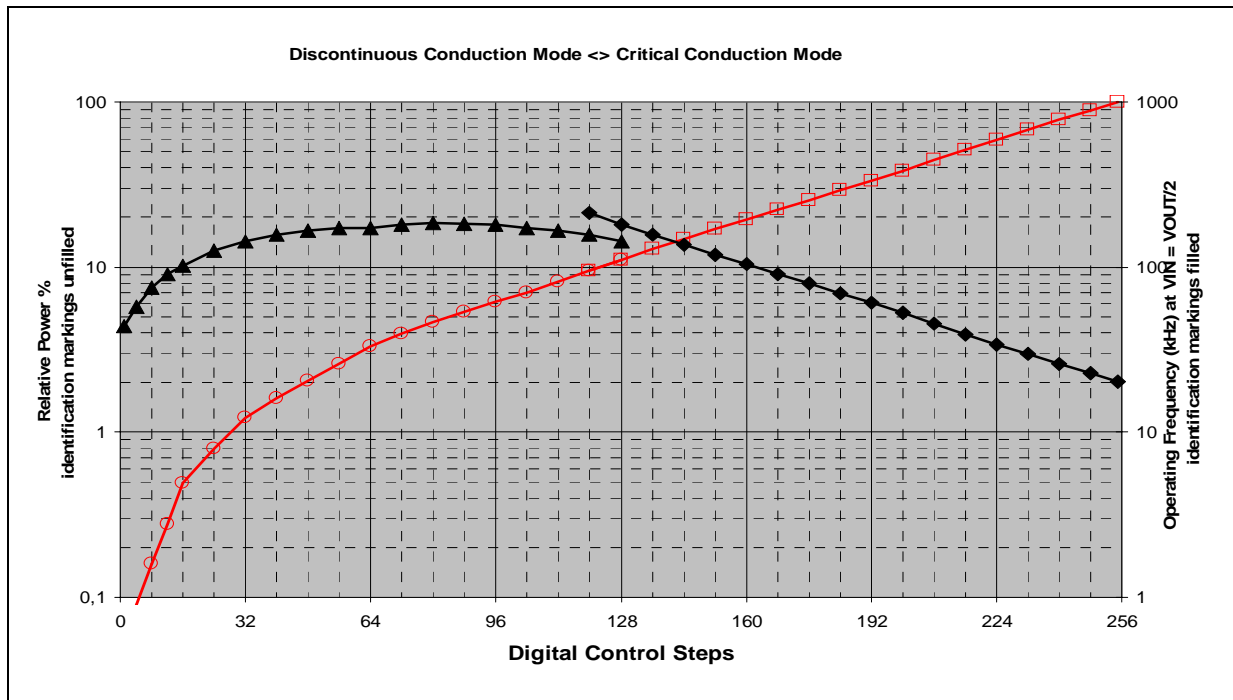

Figure 7 Relative output power and operating frequency of PFC control at $V_{IN} = V_{OUT} / 2$ versus control step.

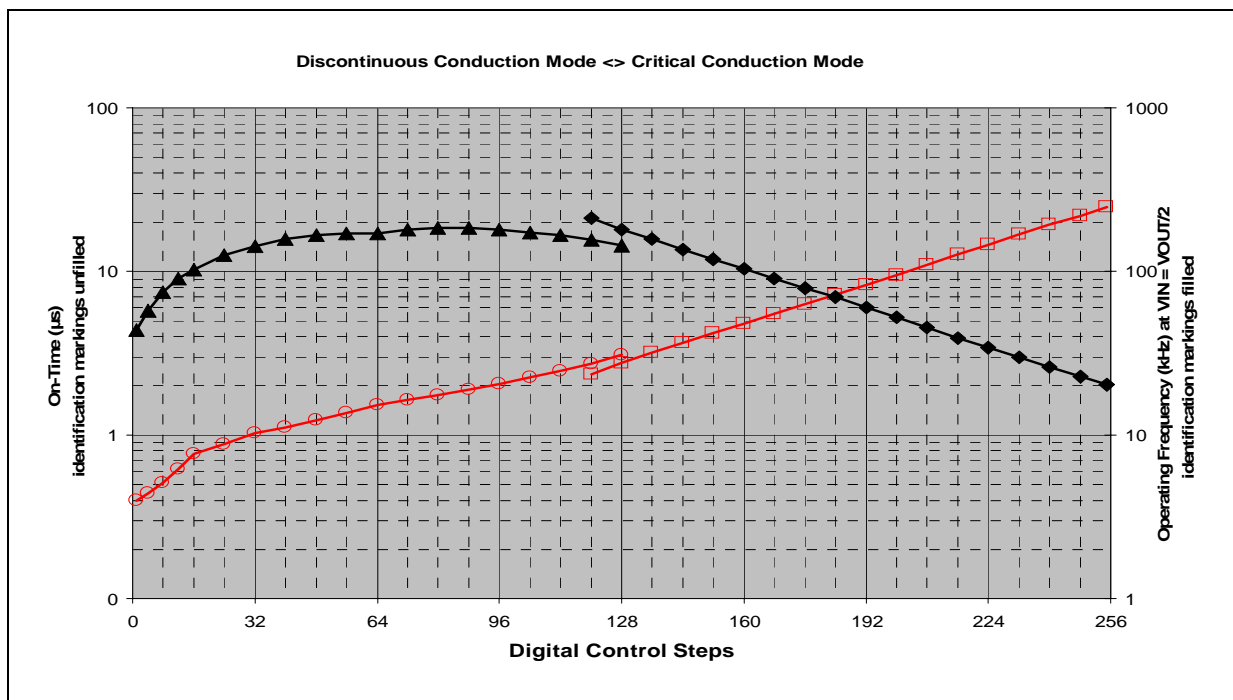

Figure 8 On-time and operating frequency of PFC control at $V_{IN} = V_{OUT} / 2$ versus control step.

3.3 Typical operating levels during start-up

Within 10ms after start-up the inverter shifts operating frequency from 125kHz to the preheating frequency set by resistor at pin RFPH. Preheating time can be selected by programming resistor at RFPH pin in steps of 17ms from 0ms to 2000ms.

After preheating the operating frequency of the inverter is shifted downwards in 40ms typically to the run frequency. During this frequency shifting the voltage and current in the resonant circuit will rise when operating close to the resonant frequency with increasing voltage across the lamp. As soon as the lower current sense level (0,8V) is reached, the frequency shift downwards is stopped and increased by a couple of frequency steps in order to limit the current and the ignition voltage also. The procedure of shifting the operating frequency up and down in order to stay within the max ignition level is limited to a time frame of 235ms. If there is no ignition within this time the control is disabled and the status is latched as a fault mode.

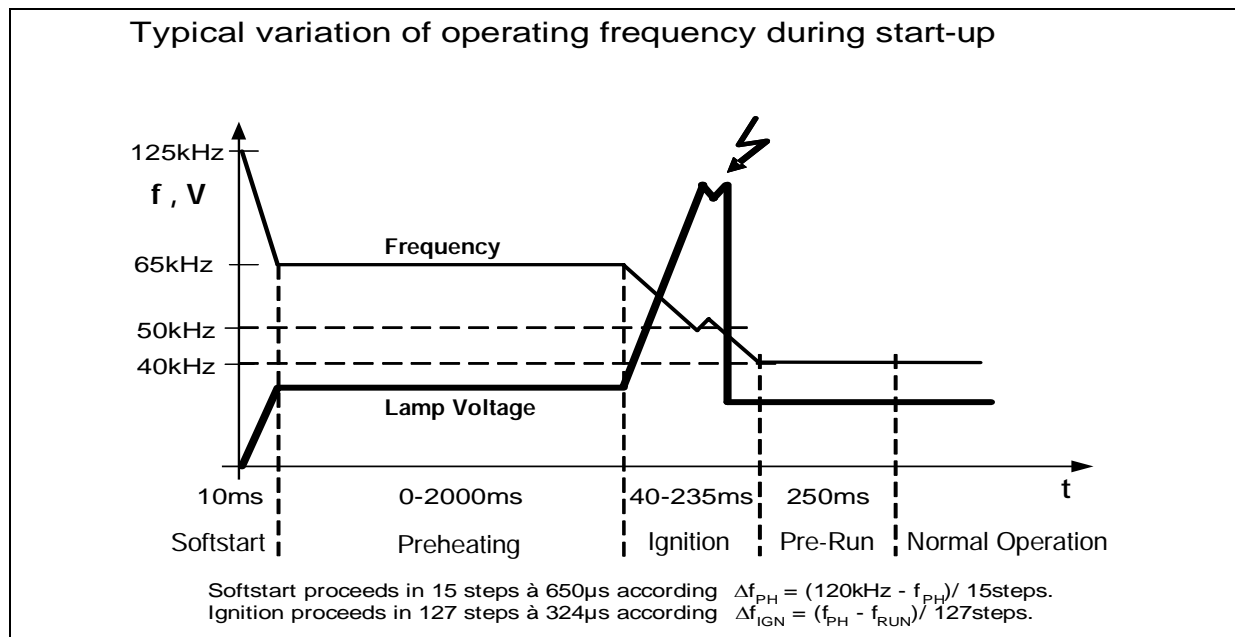

Figure 9 Typical variation of operating frequency and lamp voltage during start-up.

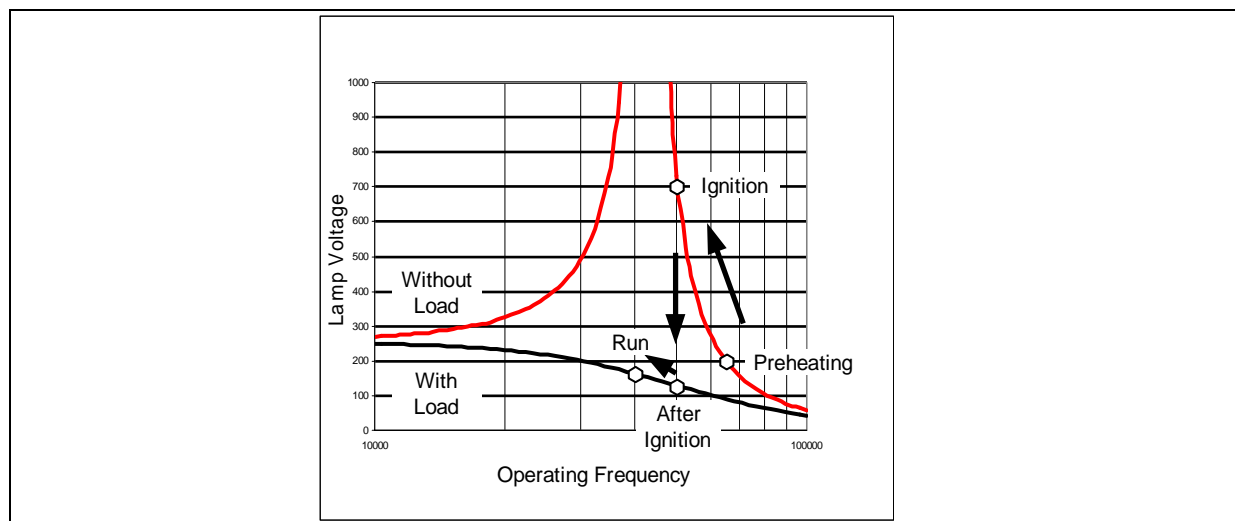

Figure 10 Typical lamp voltage versus operating frequency due to load change of the resonant circuit.

3.4 Detection of End-of-Life and Rectifier Effect

After ignition the lamp voltage breaks down to its run voltage level (typically 50Vpeak to 300Vpeak). Reaching the run frequency there follows a time period of 250ms called Pre-Run Mode, in which some of the monitoring features (EOL1, EOL2, Cap.Load1) are still disabled. In the subsequent Run Mode the End-of-life (EOL) monitoring is enabled. The event EOL1 is detected by measuring the positive and negative peak level of the lamp voltage by a current fed into the LVS pin (R17, R18, R19 in Fig. 11). If the sensed current exceeds 215 μ A for longer than 610 μ s the status end-of-life (EOL1) or the exceeding of the maximum output power is detected. In Fig. 12 the different levels of the sensed lamp voltage are illustrated.

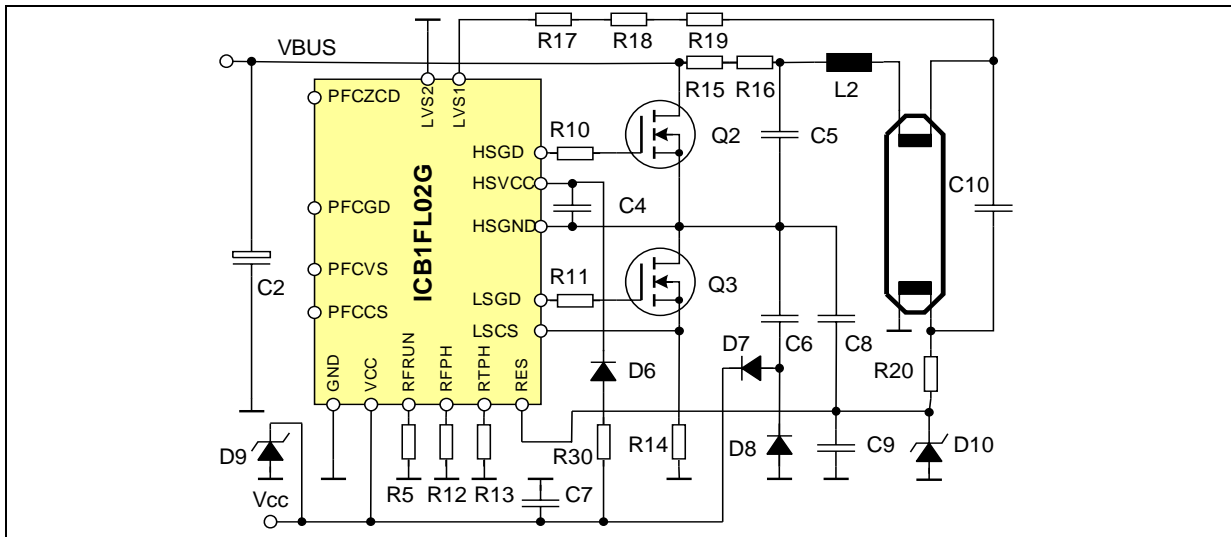

Figure 11 Circuit diagram of the lamp inverter section.

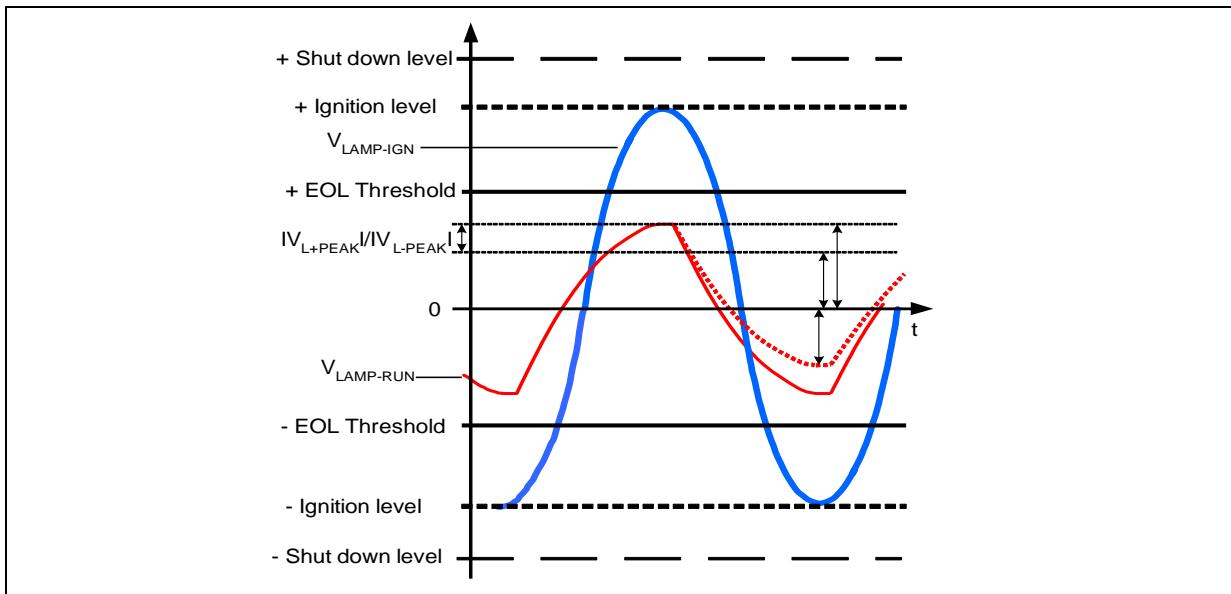

Figure 12 Sensed lamp voltage levels.

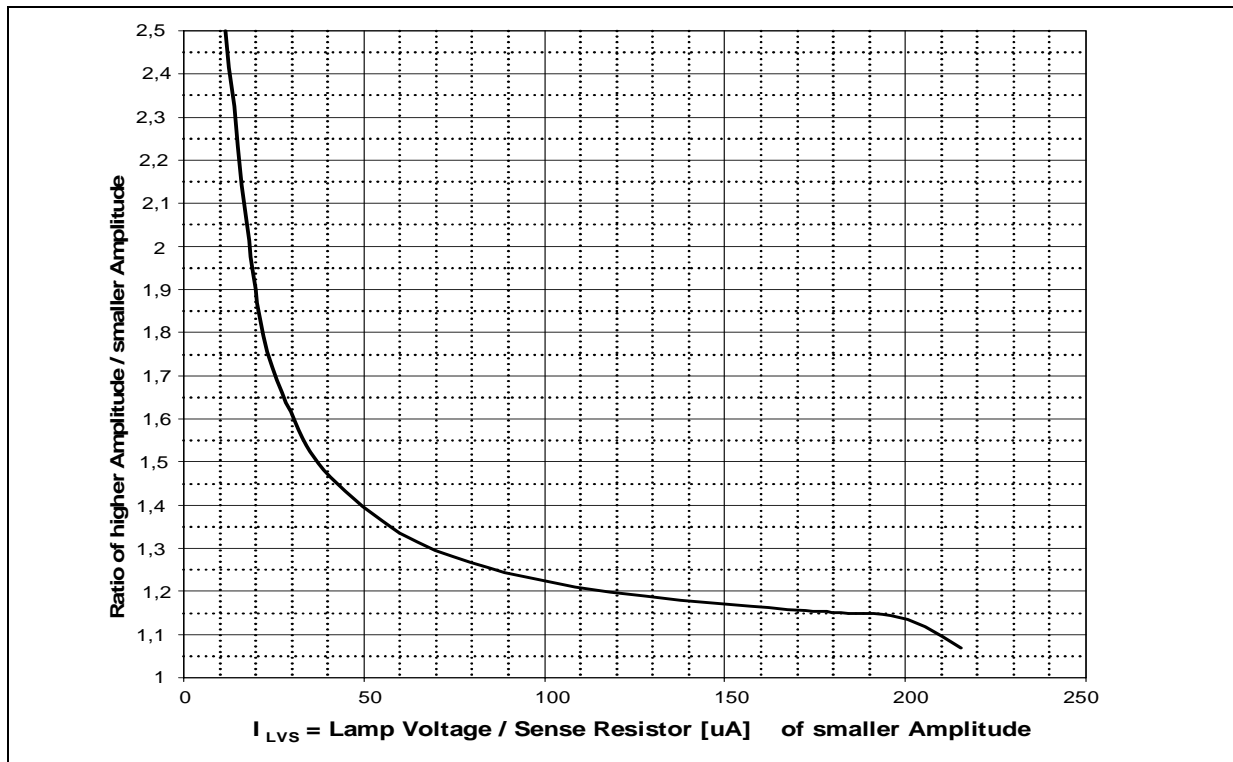

Figure 13 Maximum ratio of amplitudes versus sense current.

Furthermore the rectification effect (EOL2) is detected when the ratio of the higher amplitude divided by the smaller amplitude of the lamp voltage is bigger than illustrated in Fig. 13. for longer than 500ms. The ratio is evaluated each cycle of the lamp voltage. The limit of the ratio increases dependent on the peak current of the smaller amplitude of the lamp voltage from 1,15 at $I_{LVS}=200\mu A$ nonlinear to 1,4 at $I_{LVS}=50\mu A$.

If the EOL2 conditions are detected, the control is disabled and the status is latched as a failure mode. Measuring the duration of incorrect operating conditions is done by a check every 4ms. If the fault condition is existing, a counter counts up, if the fault condition is not existing, the counter counts down. So we get an integration of the fault events that allows a very effective monitoring of strange operating conditions.

The detection of EOL1 and EOL2 requires an AC current input at the sense pins LVS1 and LVS2 for proper operation. A DC current at pin LVS will lead to a defined reaction only, if the level exceeds $175\mu A$ (typically) for longer than $610\mu s$ which results in a shut down and change over into the latched failure mode.

3.5 Detection of capacitive mode operating conditions

If there happens a situation like an open resonant circuit (e.g. a sudden break of the tube) the voltage across the resonant capacitor and current through the shunt of the low-side inverter MOSFET rise quickly. This event is detected by inverter current limitation ($1,6V$) and results in shut down of the control. This status is latched as a failure mode.

In another kind of failure the operation of the inverter may leave the zero voltage switching (ZVS) and move into capacitive mode operation or into operation below resonance. There are two different levels for capacitive mode detection implemented in the IC. A first criteria detects low deviations from ZVS (CapLoad1) and changes operation into fault mode, if this operation lasts longer than 500ms. For CapLoad1 the same counter is used as for the end-of-life evaluation.

Functional Description

A second threshold detects severe deviations such as rectangular shapes of voltage during operation below resonance (CapLoad2). Then the inverter is turned off as soon as these conditions last longer than 610µs and the IC changes over into fault mode. The evaluation of the failure condition is done by an up and down counter which samples the status every 40µs.

CapLoad1 is sensed in the moment when low-side Gate drive is turned on. If the voltage level at pin RES is above the $V_{RES_{cap}}$ threshold (typ. 0,24V) related to the level $V_{RES_{LLV}}$, conditions of CapLoad1 are assumed.

CapLoad2 is sensed in the moment when the high-side Gate drive is turned on. If the voltage level at pin RES is below the $V_{RES_{cap}}$ threshold related to the level $V_{RES_{LLV}}$, conditions of CapLoad2 are assumed. As the reference level $V_{RES_{LLV}}$ is a floating level, it is updated every on-time of the low-side MOSFET.

D10 limits voltage transients at pin RES that can occur during removal of the lamp in run mode.

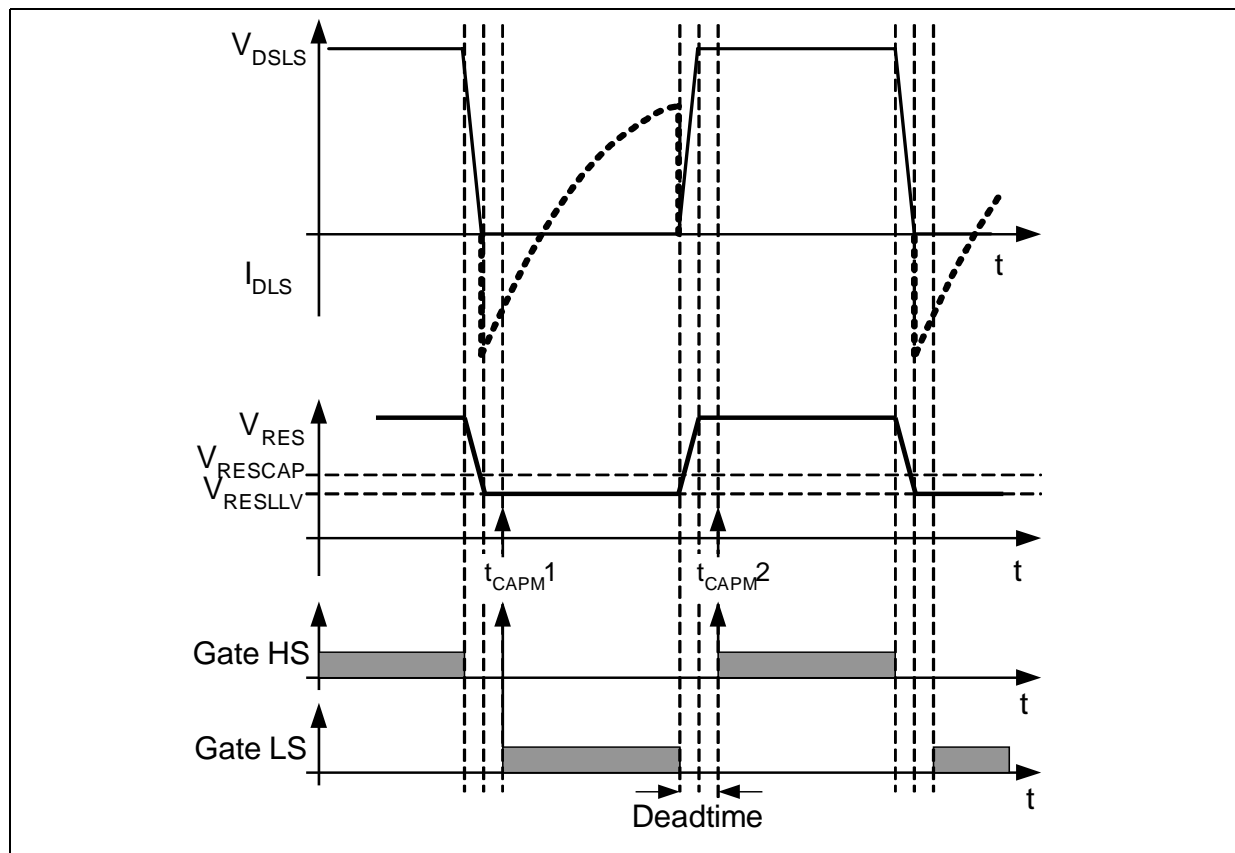

Figure 14 Levels and points in time for detection of CapLoad1 and CapLoad2.

3.6 Interruption of Operation and Restart after Lamp Removal

In the event of a failing operation the fault latch is set after the specified reaction time (e.g. 500ms at EOL2). Then the Gate drives are shut down immediately, the control functions are disabled and the current consumption is reduced to a level of 150µA (typically). V_{cc} is clamped by internal zener diode to max 17,5V at 2mA. So the internal zener diode is only designed to limit V_{cc} when fed from the start-up current, but not from the charge pump supply! There is a current limitation at the internal zener diode function (max 5mA at $V_{cc}= 17,5V$) in order to avoid conflicts with the clamping level of the external zener diode.

The capacitor at pin RES is discharged and charged during 32 cycles in order to generate a delay of several 10ms. The delay is implemented for avoiding malfunctions in detecting the lamp removal due to voltage transients that can occur after shut down. The reset of the fault latch happens after exceeding the 1,6V threshold at pin RES and enabling the IC after lamp removal and subsequent decreasing voltage level at pin RES below the 1,3V threshold.

Functional Description

The status failure mode is kept as long until a lamp removal is detected (interruption of current across filaments and detection of the return of the current) or the supply voltage drops below UVLO. After a break down of the supply voltage below the undervoltage lockout (UVLO) threshold the IC resets any failure latch and will try to restart as soon as V_{CC} exceeds the start-up threshold.

An undervoltage (75%) of the bus voltage will not be latched as a fault condition. If the undervoltage lasts longer than $80\mu s$ the Gate drives are switched off and the IC tries to restart after a V_{CC} hysteresis has been passed.

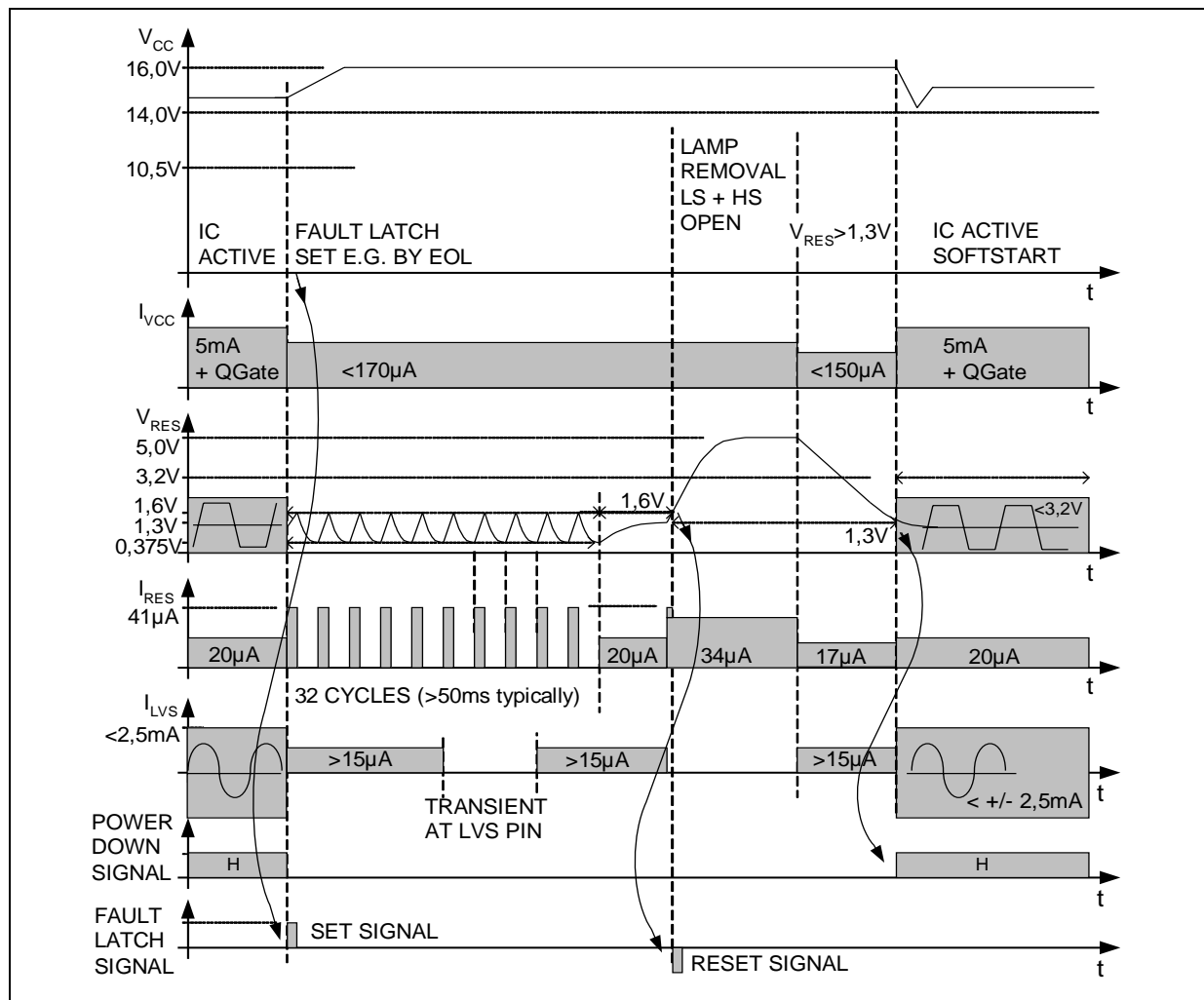

Figure 15 Interruption of operation by a fault condition and subsequent lamp removal.

4 State Diagram

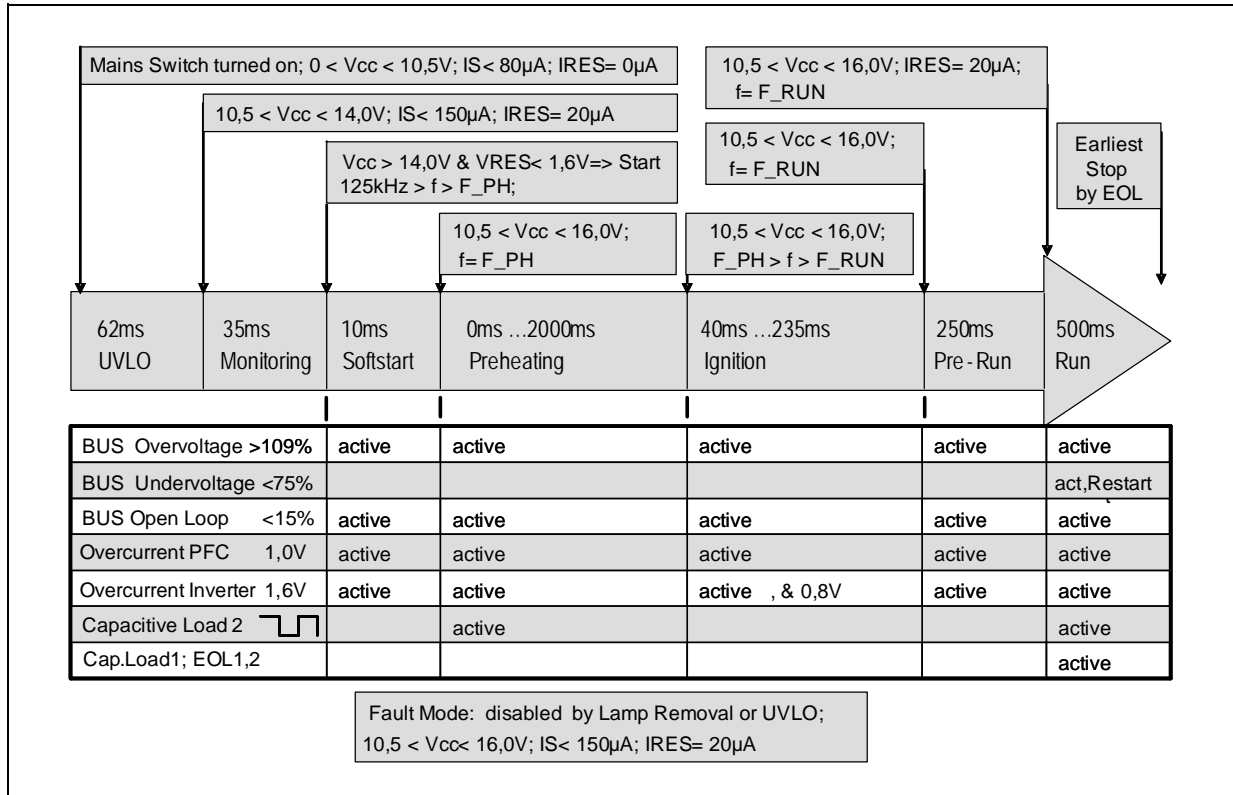

Figure 16 State Diagram

5 Protection Functions

Description of Fault	Fault-Type	Min. Duration of Effect	Detection active during					Consequence
			Softstart 10ms	Preheat Mode 0 - 2000ms	Ignition Mode 40 - 235ms	Pre-Run Mode 250ms	Run Mode	
+/- Peak Level of Lamp Voltage above threshold	EOL1	610µs					X	Power down, latched Fault Mode
Ratio of +/- amplitudes of lamp voltage > 1.15 or < 0.85	EOL2	500ms					X	Power down, latched Fault Mode
No zero voltage switching	Cap.Load 1	500ms					X	Power down, latched Fault Mode
Voltage at Pin RES > 3.0V	Open Filament	500ms					X	Power down, latched Fault Mode
Bus voltage > 109% of rated level in active operation	Overvoltage	500ms					X	Power down, latched Fault Mode
Bus voltage > 109% of rated level 10µs after power up	Overvoltage							Gate drivers off, restart after V _{CC} hysteresis
Bus voltage > 109% of rated level in active operation	PFC Overvoltage	5µs	X	X	X	X	X	Turn-off PFC MOSFET until Bus Voltage < 105%
Bus voltage < 75% of rated level	Undervoltage	80µs					X	Gate drivers off, restart after V _{CC} hysteresis
Bus voltage < 15% of rated level	Open Loop Detection	1µs	X	X	X	X	X	Power down
Capacitive Load, Operation below resonance	Cap.Load 2	610µs		X			X	Power down, latched Fault Mode
Run frequency can not be achieved	No Ignition	235ms			X			Power down, latched Fault Mode
Voltage at Pin RES > 1.6V before power up	LS open Filament	1ms						Prevents power up
Current into Pin LVS1 < 12µA	HS open Filament	1ms						Prevents power up
Current into Pin LVS2 < 12µA	HS open Filament	1ms						Prevents power up
Voltage at Pin PFCCS > 1.0V	PFC Overcurrent	260ns	X	X	X	X	X	Turn-off PFC MOSFET immediately
Voltage at Pin LSCS > 0.8V	Inverter Current Limit	250ns			X			Increases the Operating Frequency
Voltage at Pin LSCS > 1.6V	Inverter Overcurrent	400ns	X	X	X	X	X	Power Down, Latched Fault Mode
Supply voltage at Pin VCC < 14.0V before power up	Below startup threshold	1µs						Prevents power up
Supply voltage at Pin VCC < 10.5V after power up	Below UVLO threshold	1µs	X	X	X	X	X	Power Down, Reset of Latched Fault Mode

6 Electrical Characteristics

Note: All voltages without the high side signals are measured with respect to ground (pin 4). The high side voltages are measured with respect to pin17/20. The voltage levels are valid if other ratings are not violated.

6.1 Absolute Maximum Ratings

Note: Absolute maximum ratings are defined as ratings, which when being exceeded may lead to destruction of the integrated circuit. For the same reason make sure, that any capacitor that will be connected to pin 3 (VCC) and pin 18 (HSVCC) is discharged before assembling the application circuit.

Parameter	Symbol	Limit Values		Unit	Remarks
		min.	max.		
LSCS Voltage	V_{LSCS}	-5	6	V	
LSCS Current	I_{LSCS}	-3	3	mA	
LSGD Voltage	V_{LSGD}	-0.3	$V_{cc}+0.3$	V	internally clamped to 11V
VCC Voltage	V_{VCC}	-0.3	18	V	see VCC Zener Clamp
VCC Zener Clamp Current	$I_{VCCzener}$	-5	5	mA	IC in Power Down Mode
PFCGD Voltage	V_{PFCGD}	-0.3	$V_{cc}+0.3$	V	internally clamped to 11V
PFCCS Voltage	V_{PFCCS}	-5	6	V	
PFCCS Current	I_{PFCCS}	-3	3	mA	
PFCZCD Voltage	V_{PFCZCD}	-3	6	V	
PFCZCD Current	I_{PFCZCD}	-5	5	mA	
PFCVS Voltage	V_{PFCVS}	-0.3	5.3	V	
RFRUN Voltage	V_{RFRUN}	-0.3	5.3	V	
RFPH Voltage	V_{RFPH}	-0.3	5.3	V	
RTPH Voltage	V_{RTPH}	-0.3	5.3	V	
RES Voltage	V_{RES}	-0.3	5.3	V	
LVS1 Current1	I_{LVS1_1}	-1	1	mA	IC in Power Down Mode
LVS1 Current2	I_{LVS1_2}	-3	3	mA	IC in Active Mode
LVS2 Current1	I_{LVS2_1}	-1	1	mA	IC in Power Down Mode
LVS2 Current2	I_{LVS2_2}	-3	3	mA	IC in Active Mode
HSGND Voltage	V_{HSGND}	-900	900	V	referring to GND
HSGND, Voltage Transient	dV_{HSGND}/dt	-40	40	V/ns	
HSVCC Voltage	V_{HSVCC}	-0.3	18	V	referring to HSGND
HSGD Voltage	V_{HSGD}	-0.3	$V_{HSVCC}+0.3$	V	internally clamped to 11V referring to HSGND
PFCGD Peak Source Current	$I_{PFCGDs\text{omax}}$	—	150	mA	< 100ns
PFCGD Peak Sink Current	$I_{PFCGDs\text{imax}}$	—	700	mA	< 100ns
LSGD Peak Source Current	$I_{LSGDs\text{omax}}$	—	75	mA	< 100ns
LSGD Peak Sink Current	$I_{LSGDs\text{imax}}$	—	400	mA	< 100ns
HSGD Peak Source Current	$I_{HSGDs\text{omax}}$	—	75	mA	< 100ns

Electrical Characteristics

HSGD Peak Sink Current	I_{HSGDsmax}	—	400	mA	< 100ns
Junction Temperature	T_j	-25	150	°C	
Storage Temperature	T_s	-55	150	°C	
Max possible Power Dissipation	P_{tot}	—	2	W	PG-DSO-18-1, $T_{\text{amb}} = 25^\circ\text{C}$
Thermal Resistance (Both Chips) Junction-Ambient	R_{thJA}	—	60	K/W	PG-DSO-18-1
Thermal Resistance (HS Chips) Junction-Ambient	R_{thJAHS}	—	120	K/W	PG-DSO-18-1
Thermal Resistance (LS Chips) Junction-Ambient	R_{thJALS}	—	120	K/W	PG-DSO-18-1
Soldering Temperature			260	°C	wave sold. acc.JESD22A111
ESD Capability	V_{ESD}	—	2	kV	Human body model ¹⁾

¹⁾ According to EIA/JESD22-A114-B (discharging an 100pF capacitor through an 1.5kΩ series resistor).

6.2 Operating Range

Parameter	Symbol	Limit Values		Unit	Remarks
		min.	max.		
HSVCC Supply Voltage	V_{HSVCC}	V_{HSVCCoff}	17.0	V	referring to HSGND
HSGND Supply Voltage	V_{HSGND}	-900	900	V	referring to GND
VCC Supply Voltage	V_{VCC}	V_{VCCoff}	17.5	V	
LSCS Voltage Range	V_{LSCS}	-4	5	V	
PFCVS Voltage Range	V_{PFCVS}	0	4	V	
PFCCS Voltage Range	V_{PFCCS}	-4	5	V	
PFCZCD Current Range	I_{PFCZCD}	-4	4	mA	
LVS1, LVS2 Voltage Range	$V_{\text{LVS1,LVS2}}$	-0.3	¹⁾	V	IC in Power Down Mode
LVS1, LVS2 Current Range	$I_{\text{LVS1,LVS2}}$	²⁾	300	μA	IC in Power Down Mode
LVS1, LVS2 Current Range	$I_{\text{LVS1,LVS2}}$	-2.5	2.5	mA	IC in Active Mode
Junction Temperature	T_j	-25	125	°C	
Adjustable Preheating Frequency Range set by RFPH	F_{RFPH}	F_{RFRUN}	150	kHz	
Adjustable Run Frequency Range set by RFRUN	F_{RFRUN}	20	100	kHz	
Adjustable Preheating Time Range set by RTPH	t_{RTPH}	0	1980	ms	
Set Resistor for Run Frequency	R_{RFRUN}	5	25	kΩ	
Set Resistor for Preheating Frequency (R_{RFRUN} parallel R_{RFPH})	R_{RFRUN} R_{RFPH}	3.3		kΩ	
Set Resistor for Preheating Time	R_{RTPH}	0	20	kΩ	

¹⁾ Limited by maximum of current range at LVS1, LVS2

²⁾ Limited by minimum of voltage range at LVS1, LVS2

Electrical Characteristics
6.3 Characteristics
6.3.1 Power Supply Section

Note: The electrical characteristics involve the spread of values given within the specified supply voltage and junction temperature range T_j from -25°C to 125°C . Typical values represent the median values, which are related to 25°C . If not otherwise stated, a supply voltage of $V_{CC} = 15\text{V}$ and $V_{HSVCC} = 15\text{V}$ is assumed and the IC operates in active mode. Furthermore all voltages are referring to GND if not otherwise mentioned.

Parameter	Symbol	Limit Values			Unit	Test Condition
		min.	typ.	max.		
High Side Leakage Current	$I_{\text{HSGNDleak}}$		0.01	2	μA	$V_{\text{HSGND}} = 800\text{V}$ $V_{\text{GND}} = 0\text{V}$
VCC Quiescent Current	I_{VCCqu1}		80	120	μA	$V_{\text{VCC}} = V_{\text{VCCoff}} - 0.5\text{V}$
VCC Quiescent Current	I_{VCCqu2}		110	150	μA	$V_{\text{VCC}} = V_{\text{VCCon}} - 0.5\text{V}$
VCC Supply Current with Inactive Gates	I_{VCCsup1}		5	7	mA	$V_{\text{PFCVS}} > 2.725\text{V}$
VCC Supply Current in Latched Fault Mode	I_{VCClatch}	—	110	170	μA	$V_{\text{RES}} = 5\text{V}$
LS VCC Turn-On Threshold	V_{VCCon}	13.6	14.1	14.6	V	
LS VCC Turn-Off Threshold	V_{VCCoff}	10.0	10.5	11.0	V	
LSVCC Turn-On/Off Hysteresis	V_{VCChys}	3.2	3.6	4.0	V	
VCC Zener Clamp Voltage	V_{VCCclmp}	15.7	16.3	16.9	V	$I_{\text{VCC}} = 2\text{mA}$ $V_{\text{RES}} = 5\text{V}$
VCC Zener Clamp Current	I_{VCCzener}	2.5	—	5	mA	$V_{\text{VCC}} = 17.5\text{V}$ $V_{\text{RES}} = 5\text{V}$
HSVCC Quiescent Current	$I_{\text{HSVCCqu}}^{1)}$	—	170	250	μA	$V_{\text{HSVCC}} = V_{\text{HSVCCon}} - 0.5\text{V}$
HSVCC Supply Current with Inactive Gate	$I_{\text{HSVCCsup1}}^{1)}$	—	0.65	1.2	mA	
HSVCC Turn-On Threshold	$V_{\text{HSVCCon}}^{1)}$	9.6	10.1	10.7	V	
HSVCC Turn-Off Threshold	$V_{\text{HSVCCoff}}^{1)}$	7.9	8.4	9.1	V	
HSVCC Turn-On/Off Hysteresis	$V_{\text{HSVCChys}}^{1)}$	1.4	1.7	2.0	V	

¹⁾ With reference to High Side Ground HSGND

Electrical Characteristics
6.3.2 PFC Section
6.3.2.1 PFC Current Sense (PFCCS)

Parameter	Symbol	Limit Values			Unit	Test Condition
		min.	typ.	max.		
Turn-Off Threshold	$V_{PFCCSoff}$	0.95	1.0	1.05	V	
Duration of Overcurrent for turn-off	$t_{PFCCSoff}$	200	250	320	ns	
Spike Blanking	$t_{blanking}$	140	200	260	ns	
PFCCS Bias Current	$I_{PFCCSbias}$	-0.5		0.5	μA	$V_{PFCCS} = 1.5V$

6.3.2.2 PFC Zero Current Detector (PFCZCD)

Parameter	Symbol	Limit Values			Unit	Test Condition
		min.	typ.	max.		
Zero Crossing Upper Threshold	$V_{PFCZCDup}$	1.4	1.5	1.6	V	
Zero Crossing Lower Threshold	$V_{PFCZCDlow}$	0.4	0.5	0.6	V	
Zero Crossing Hysteresis	$V_{PFCZCDhys}$		1.0		V	
Clamping of Positive Voltages	$V_{PFCZCDpclip}$	5.0	6.3	7.2	V	$I_{PFCZCD} = 4mA$
Clamping of Negative Voltages	$V_{PFCZCDnclip}$	-3.5	-2.9	-2.0	V	$I_{PFCZCD} = 4mA$
PFCZCD Bias Current	$I_{PFCZCDbias}$	-0.5		0.5	μA	$V_{PFCZCD} = 1.7V$
PFCZCD Ringing Suppression Time	t_{ringup}	350	500	650	ns	

6.3.2.3 PFC Bus Voltage Sense (PFCVS)

Parameter	Symbol	Limit Values			Unit	Test Condition
		min.	typ.	max.		
Trimmed Reference Voltage	$V_{PFCVSref}$	2.47	2.5	2.53	V	
Overvoltage Upper Detection Limit	$V_{PFCVSup}$	2.675	2.725	2.78	V	
Overvoltage Lower Detection Limit	$V_{PFCVSlow}$	2.57	2.625	2.67	V	
Overvoltage Hysteresis	$V_{PFCVShys}$	70	100	130	mV	
Undervoltage Detection Limit	$V_{PFCVSuv}$	1.79	1.83	1.87	V	
Undervoltage Shut Down	$V_{PFCVSSd}$	0.30	0.375	0.45	V	
Bias Current (ESD-Stress<1KV)	$I_{PFCVsbias}$	-1		1	μA	$V_{PFCVS} = 2.5V$
Bias Current (ESD-Stress>1KV)	$I_{PFCVsbias}$	-2.5		2.5	μA	$V_{PFCVS} = 2.5V$

Electrical Characteristics
6.3.2.4 PFC PWM Generation

Parameter	Symbol	Limit Values			Unit	Test Condition
		min.	typ.	max.		
Initial On-Time	$t_{\text{PFCOn-initial}}$	2.0	3.0	3.8	μs	$V_{\text{PFCZCD}} = 0\text{V}$
Max. On-Time	$t_{\text{PFCOn-max}}$	19	23.5	28	μs	$0.45\text{V} < V_{\text{PFCVS}} < 2.45\text{V}$
Repetition Time when missing Zero Crossing	t_{PFCrep}	38	50	62	μs	$V_{\text{PFCZCD}} = 0\text{V}$
Off-time when missing ZCD Signal	t_{PFCoff}	35	42	49	μs	$V_{\text{PFCZCD}} = 0\text{V}$

6.3.2.5 PFC Gate Drive (PFCGD)

Parameter	Symbol	Limit Values			Unit	Test Condition
		min.	typ.	max.		
PFCGD Low Voltage	V_{PFCGDlow}	0.4	0.7	0.9	V	$I_{\text{PFCGD}} = 5\text{mA}$
		0.4	0.75	1.1	V	$I_{\text{PFCGD}} = 20\text{mA}$
		-0.1	0.3	0.6	V	$I_{\text{PFCGD}} = -20\text{mA}$
PFCGD High Voltage	$V_{\text{PFCGDhigh}}$	10.2	11	11.8	V	$I_{\text{PFCGD}} = -20\text{mA}$
		9.0	—	—	V	$I_{\text{PFCGD}} = -1\text{mA}$ $V_{\text{VCC}} = V_{\text{VCCoff}} + 0.3\text{V}$
		8.5	—	—	V	$I_{\text{PFCGD}} = -5\text{mA}$ $V_{\text{VCC}} = V_{\text{VCCoff}} + 0.3\text{V}$
PFCGD Voltage Active Shut Down	V_{PFCGDsd}	0.4	0.75	1.1	V	$I_{\text{PFCGD}} = 20\text{mA}$ $V_{\text{VCC}} = 5\text{V}$
PFCGD Peak Source Current	$I_{\text{PFCGDsource}}$	—	100	—	mA	$R_{\text{load}} = 4\Omega$ $+ C_{\text{Load}} = 3.3\text{nF}^{1)}$
PFCGD Peak Sink Current	$I_{\text{PFCGDsink}}$	—	-500	—	mA	$R_{\text{load}} = 4\Omega$ $+ C_{\text{Load}} = 3.3\text{nF}^{1)}$
PFCGD Rise Time $2\text{V} < V_{\text{LSGD}} < 8\text{V}$	$t_{\text{PFCGDrise}}$	110	220	400	ns	$R_{\text{load}} = 4\Omega$ $+ C_{\text{Load}} = 3.3\text{nF}$
PFCGD Fall Time $8\text{V} > V_{\text{LSGD}} > 2\text{V}$	$t_{\text{PFCGDfall}}$	20	45	70	ns	$R_{\text{load}} = 4\Omega$ $+ C_{\text{Load}} = 3.3\text{nF}$

¹⁾ The parameter is not subject to production test - verified by design/characterization

6.3.3 Inverter Section
6.3.3.1 Inverter Control (RFRUN, RFPH, RTPH)

Parameter	Symbol	Limit Values			Unit	Test Condition
		min.	typ.	max.		
Fixed Start-Up Frequency	F_{startup}	112	125	138	kHz	
Duration of Soft Start, shift F from Start-Up to Preheating Frequency	$t_{\text{softstart}}$	9.0	11.0	13.5	ms	
Preheating Frequency	F_{RFPH1}	97.0	100	103.0	kHz	$R_{\text{RFPH}} = 10\text{k}\Omega$ $R_{\text{RFRUN}} = 10\text{k}\Omega$
Run Frequency	F_{RFRUN1}	49.0	50.0	51.0	kHz	$R_{\text{RFRUN}} = 10\text{k}\Omega$
Preheating Time	t_{RTPH1}	720	900	1080	ms	$R_{\text{RTPH}} = 8.06\text{k}\Omega$
Preheating Time	t_{RTPH2}	50	90	130	ms	$R_{\text{RTPH}} = 806\Omega^{1)}$
Current Source Preheating Time	I_{RTPH}	132	140	148	μA	
Min. Duration of Ignition, shift F from Preheating to Run Frequency	t_{IGNITION}	34	40	48	ms	¹⁾
Max. Duration of Ignition, shift F from Preheating to Run Frequency	$t_{\text{NOIGNITION}}$	210	235	290	ms	¹⁾
Duration of Pre-Run, time period after operating frequency has reached Run Frequency first time after ignition	t_{PRERUN}	210	250	290	ms	¹⁾
Minimum Duration of fault condition by EOL2, Cap.Load 1, Open filament and Overvoltage for entering latched Fault Mode	t_{CAPLOAD1}	420	500	580	ms	¹⁾
Minimum Duration of fault condition by EOL1, Cap.Load 2 for entering latched Fault Mode	t_{CAPLOAD2}	520	610	770	μs	

¹⁾ The parameter is not subject to production test - verified by design/characterization

6.3.3.2 Inverter Low Side Current Sense (LSCS)

Parameter	Symbol	Limit Values			Unit	Test Condition
		min.	typ.	max.		
Current Limit Threshold during Ignition Mode	$V_{\text{LSCSlimit}}$	0.76	0.80	0.84	V	
Duration of Current above Threshold for enabling Frequency Increase	$t_{\text{LSCSlimit}}$	200	250	320	ns	
Overcurrent Shut Down Threshold	V_{LSCSovc}	1.55	1.60	1.65	V	
Duration of Overcurrent for entering Latched Fault Mode	t_{LSCSovc}	320	400	480	ns	
Bias Current LSCS	I_{LSCSbias}	-0.5		0.5	μA	$V_{\text{LSCS}} = 1.5\text{V}$
Inverter Dead Time between LS off and HS on	t_{deadtime}	1.50	1.75	2.0	μs	

Electrical Characteristics
6.3.3.3 Restart after Lamp Removal (RES)

Parameter	Symbol	Limit Values			Unit	Test Condition
		min.	typ.	max.		
Low-side Open Filament Threshold	$V_{RESofil}$	3.1	3.2	3.3	V	
Capacitive Load Detection Threshold	V_{REScap}	0.18	0.24	0.30	V	
Discharge Resistor during Latched Fault Mode	$R_{RESdisch}$	37	56	75	k Ω	
I1 Current Source	I_{RES1}	-54.3	-41	-30.0	μ A	$V_{RES}=1V$; $LVS1=5\mu A$
I2 Current Source	I_{RES2}	-46	-34	-24.2	μ A	$V_{RES}=2V$; $LVS1=5\mu A$
I3 Current Source	I_{RES3}	-27.0	-20	-15.1	μ A	$V_{RES}=1V$; $LVS1=50\mu A$
I4 Current Source	I_{RES4}	-22.6	-17	-12.3	μ A	$V_{RES}=2V$; $LVS1=50\mu A$
C1 Comparator Threshold	V_{RESC1}	1.55	1.6	1.65	V	
C2 Comparator Threshold	V_{RESC2}	1.25	1.3	1.35	V	
C3 Comparator Threshold	V_{RESC3}	0.32	0.375	0.46	V	

6.3.3.4 Lamp Voltage Sense (LVS1, LVS2)

Parameter	Symbol	Limit Values			Unit	Test Condition
		min.	typ.	max.		
Source Current before Start Up	$I_{LVSource}$	-8	-5	-2	μ A	$11 < V_{VCC} < 13V$ $V_{LVS} = 0V$
Threshold for enabling Lamp Monitoring	$V_{LVSenable}$	1.5	2.3	3.0	V	$11 < V_{VCC} < 13V$
Sink Current Threshold for Lamp Detection	I_{LVSink}	9	15	26	μ A	$V_{LVS} > V_{VCC}$
Positive EOL Current Threshold	$I_{LVSpEOLAC}$	185	215	250	μ A	$T > 0^{\circ}C$, AC input
Negative EOL Current Threshold	$I_{LVSnEOLAC}$	-250	-215	-185	μ A	$T > 0^{\circ}C$, AC input
EOL Current Threshold	$I_{LVSEOLDC}$	+/-145	+/-175	+/-210	μ A	$T > 0^{\circ}C$, DC input
Maximum Ratio between positive and negative Current Amplitude ¹⁾	$RO_{LVS1MAX}$ $RO_{LVS2MAX}$	1.1	1.2	1.3		$I_{LVSourcepeak}=150\mu A$ $I_{LVSinkpeak}=\text{increasing}$
Minimum Ratio between positive and negative Current Amplitude ¹⁾	$RO_{LVS1MIN}$ $RO_{LVS2MIN}$	0.75	0.85	0.95		$I_{LVSinkpeak}=150\mu A$ $I_{LVSourcepeak}=\text{increasing}$
Positive Clamping Voltage	I_{LVScmp}	-	$V_{VCC} + 1V$	-	V	$I_{LVS} = 300\mu A$

1) Referring to the following equations:

$$RO_{LVS} = \frac{I_{LVS\text{sinkpeak}}^{(n+1)}}{I_{LVS\text{sourcepeak}}^{(n)}}$$

$$RO_{LVS} = \frac{I_{LVS\text{source}}^{(n+2)}}{I_{LVS\text{sinkpeak}}^{(n+1)}}$$

6.3.3.5 Inverter Low Side Gate Drive (LSGD)

Parameter	Symbol	Limit Values			Unit	Test Condition
		min.	typ.	max.		
LSGD Low Voltage	$V_{LSGD\text{low}}$	0.4	0.7	1.0	V	$I_{LSGD} = 5\text{mA}$
		0.5	0.8	1.2	V	$I_{LSGD} = 20\text{mA}$
		-0.3	0.1	0.4	V	$I_{LSGD} = -20\text{mA}$
LSGD High Voltage	$V_{LSGD\text{high}}$	10.0	10.8	11.6	V	$I_{PFCGD} = -20\text{mA}$
		9.0	—	—	V	$I_{PFCGD} = -1\text{mA}$ $V_{VCC} = V_{VCC\text{off}} + 0.3\text{V}$
		8.5	—	—	V	$I_{PFCGD} = -5\text{mA}$ $V_{VCC} = V_{VCC\text{off}} + 0.3\text{V}$
LSGD Voltage Active Shut Down	$V_{LSGD\text{sds}}$	0.5	0.8	1.2	V	$I_{HSGD} = 20\text{mA}$ $V_{HSVCC} = 5\text{V}$
LSGD Peak Source Current	$I_{LSGD\text{source}}$	—	50	—	mA	$R_{\text{load}} = 10\Omega + C_{\text{Load}} = 1\text{nF}^{1)}$
LSGD Peak Sink Current	$I_{LSGD\text{sink}}$	—	-300	—	mA	$R_{\text{load}} = 10\Omega + C_{\text{Load}} = 1\text{nF}^{1)}$
LSGD Rise Time $2\text{V} < V_{LSGD} < 8\text{V}$	$t_{LSGD\text{rise}}$	110	220	400	ns	$R_{\text{load}} = 10\Omega + C_{\text{Load}} = 1\text{nF}$
LSGD Fall Time $8\text{V} > V_{LSGD} > 2\text{V}$	$t_{LSGD\text{fall}}$	20	35	60	ns	$R_{\text{load}} = 10\Omega + C_{\text{Load}} = 1\text{nF}$

1) The parameter is not subject to production test - verified by design/characterization

Electrical Characteristics
6.3.3.6 Inverter High Side Gate Drive (HSGD)

Parameter	Symbol	Limit Values			Unit	Test Condition
		min.	typ.	max.		
HSGD Low Voltage	V_{HSGDlow}	0.02	0.05	0.1	V	$I_{\text{HSGD}} = 5\text{mA}$
		0.5	1.1	2.5	V	$I_{\text{HSGD}} = 100\text{mA}$
		-0.4	-0.2	-0.05	V	$I_{\text{HSGD}} = -20\text{mA}$
HSGD High Voltage	V_{HSGDhigh}	9.5	10.5	11.0	V	$I_{\text{HSGD}} = -20\text{mA}$
		7.8	—	—	V	$I_{\text{HSGD}} = -1\text{mA}$ $V_{\text{HSVCC}} = V_{\text{HSVCCoff}} + 0.3\text{V}$
HSGD Voltage Active Shut Down	V_{HSGDsd}	0.05	0.22	0.50	V	$I_{\text{HSGD}} = 20\text{mA}$ $V_{\text{HSVCC}} = 5\text{V}$
HSGD Peak Source Current	$I_{\text{HSGDsource}}$	—	50	—	mA	$R_{\text{load}} = 10\Omega + C_{\text{Load}} = 1\text{nF}^{1)}$
HSGD Peak Sink Current	I_{HSGDsink}	—	-300	—	mA	$R_{\text{load}} = 10\Omega + C_{\text{Load}} = 1\text{nF}^{1)}$
HSGD Rise Time $2\text{V} < V_{\text{HSGD}} < 8\text{V}$	t_{HSGDrise}	140	220	300	ns	$R_{\text{load}} = 10\Omega + C_{\text{Load}} = 1\text{nF}$
HSGD Fall Time $8\text{V} > V_{\text{HSGD}} > 2\text{V}$	t_{HSGDfall}	20	35	70	ns	$R_{\text{load}} = 10\Omega + C_{\text{Load}} = 1\text{nF}$

¹⁾ The parameter is not subject to production test - verified by design/characterization

7 Application Examples

7.1 Operating Behaviour of a Ballast for a single Fluorescent Lamp

After turning on the mains switch the peak value of the rectified AC input voltage is available at C02 and smoothing capacitor C10 (Fig. 17). Via R11 and R12 the supply voltage increases at bypass capacitors C12 and C13. At a level of 10,5V a source current out of pin RES is sensing the existence of the low-side filament of the fluorescent lamp. Fed from the BUS voltage a current is detected at pin LVS1 via R31...R35, when the high-side filament is connected. The current fed into pin LVS1 is used to charge C12 via internal clamping diode. The IC changes into active mode when Vcc level achieves the turn-on threshold of 14V and both filaments are detected. If not required the pin LVS2 can be disabled by connecting to GND.

The active IC is sensing the BUS voltage level via R14, R15. Gate drives are disabled when open loop or overvoltage are detected. If BUS voltage level is within the allowed range, the low-side Gate drive is starting with the first pulse of the 125kHz softstart frequency. Only few cycles are required to charge the bootstrap capacitor C14 via D6, R30 and Q3. Without R30 there is a risk of overcurrent shut down by exceeding the 1,6V threshold at pin LSCS. The power supply is generated by a charge pump C16, D7 and D8. In normal operation C16 is charged and discharged via C17 from the current forced by the resonance inductor L2 during the deadtime of the inverter producing a zero voltage switching (ZVS) operation. Run frequency, preheating frequency and preheating time are set by resistors R21, R22 and R23.

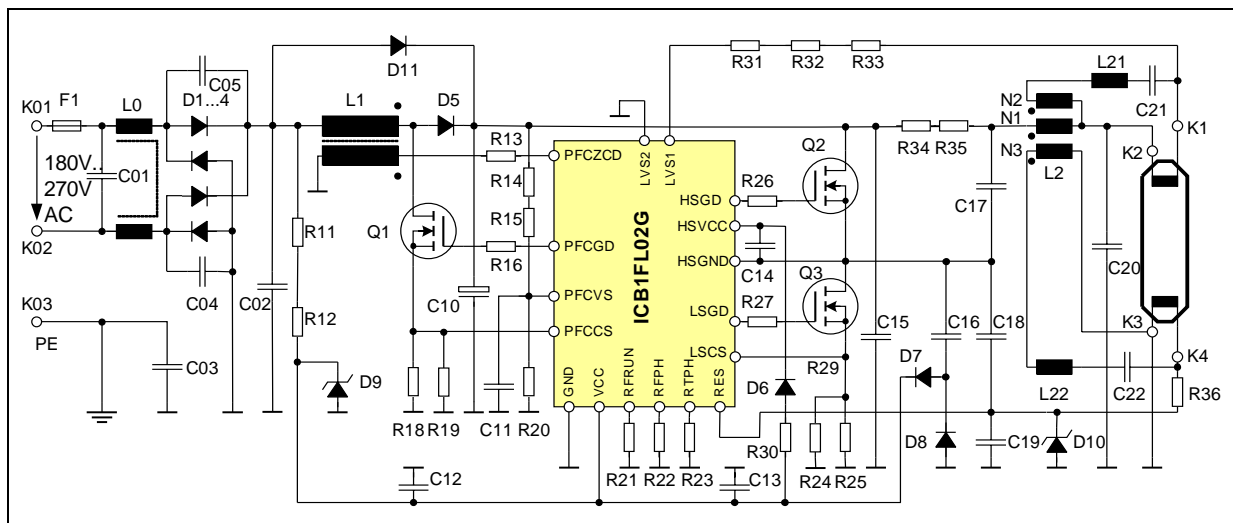

Figure 17 Application circuit of a Ballast for a single Fluorescent Lamp with voltage mode Preheating.

During run mode the lamp voltage is sensed via R31...R33 in order to detect an abnormal increasing of lamp voltage or an rectifier effect that can occur at end-of-life conditions of the lamp. At the pin RES there is also detected a non-ZVS operation, classified into Capmode1 and Capmode2. This will be done by the capacitive divider C18, C19, that transfers the divided AC-part of the inverter output voltage to pin RES. Dependent on the shape of the signal two different time windows can be started at abnormal conditions in order to protect the ballast. Zener diode D10 limits voltage transients at pin RES that can occur during removal of the lamp.

Voltage mode preheating is done by two separate windings on the resonant inductor L2. The bandpass filters L21, C21 and L22, C22 are designed to pass preheating current at preheating frequency only and to block any current during run mode. Ignition is provided by shifting the operating frequency towards the resonant frequency of L2 and C20. The voltage level during ignition is limited by the current sensed at Shunt resistors R24, R25 with a level of 0,8V at pin LSCS. Overcurrents that exceed a voltage level of 1,6V for longer than 400ns will disable the IC at any time and change into fault mode.

The PFC preconverter with L1, Q1 and D5 is starting with a fixed frequent operation and change over to a critical conduction mode (CritCM) as soon as the level at pin PFCZCD is sufficient to trigger the operation. During light load the operation mode changes into discontinuous conduction mode (DCM). Compensation of the voltage control loop is completely integrated with a digital filter and error amplifier. PFC overcurrent is sensed by R18, R19, Bus overvoltage and undervoltage at pin PFCVS. A bypass diode D11 between the DC side of the mains rectifier and BUS capacitor is recommended in order to avoid an overload of the PFC MOSFET Q1.

7.2 Design Equations of a Ballast Application

Subsequent the design equations are listed:

Start-up resistors R11, R12:

$$R_{11} + R_{12} = \frac{V_{INMIN}}{I_{VCCqu2}} = \frac{200V}{150\mu A} = 1,33M\Omega$$

Selected value: R11= 470k; R12= 470k

Current limitation resistor R13 of PFC zero current detector (PFCZCD).
The additional factor 2 is used in order to keep away from limit value.

$$R_{13} = \frac{V_{BUS} \cdot N_{SEC} \cdot 2}{I_{PFCZCD} \cdot N_{PRIM} \cdot 1} = \frac{410V \cdot 13 \cdot 2}{4mA \cdot 128 \cdot 1} = 20,8k\Omega$$

Selected value: R13= 33k.

PFC Voltage sense resistor R20:

$$R_{20} \leq \frac{V_{REF}}{100 \cdot I_{PFCBIAS}} = \frac{2,50V}{100 \cdot 2,5\mu A} = 10k\Omega$$

Selected value: R20= 10k.

PFC Voltage sense resistors R14, R15:

$$R_{14} + R_{15} = \frac{V_{BUS} - V_{REF}}{V_{REF}} \cdot R_{20} = \frac{410V - (2,5V)}{2,5V} \cdot 10k = 1630k\Omega$$

Selected values: R14= 820k; R15= 820k

Low pass capacitor C11:

Selected corner frequency $f_{C1} = 10kHz$.

$$C_{11} = \frac{1 \cdot (R_{20} + R_{14} + R_{15})}{2 \cdot \pi \cdot f_{C1} \cdot R_{20} \cdot (R_{14} + R_{15})} = \frac{1 \cdot (10k + 820k + 820k)}{2 \cdot \pi \cdot 10kHz \cdot 10k \cdot (820k + 820k)} = 1,60nF$$

Selected value C3= 2,2nF

PFC Shunt resistors R18, R19:

$$\frac{R_{18} \cdot R_{19}}{R_{18} + R_{19}} = \frac{V_{PFCCSOFF} \cdot \eta \cdot V_{INACMIN} \cdot \sqrt{2}}{4 \cdot P_{OUTPFC}} = \frac{1V \cdot 0,95 \cdot 180V \cdot \sqrt{2}}{4 \cdot 55W} = 1,1\Omega$$

Selected values: R18= 2,2Ohm; R19= 2,2Ohm

Set resistor R21 for run frequency, at a projected run frequency of 45kHz:

$$R_{21} = R_{FRUN} = \frac{5 \cdot 10^8 \cdot \Omega\text{Hz}}{f_{RUN}} = \frac{5 \cdot 10^8 \cdot \Omega\text{Hz}}{45\text{kHz}} = 11,1\text{k}\Omega$$

Selected value: R21= 11,0k

Set resistor R22 for preheating frequency, at a projected preheating frequency of 105kHz:

$$R_{22} = R_{FPH} = \frac{R_{FRUN}}{\frac{f_{PH} \cdot R_{FRUN}}{5 \cdot 10^8 \cdot \Omega\text{Hz}} - 1} = \frac{11,0\text{k}}{\frac{105\text{kHz} \cdot 11,0\text{k}}{5 \cdot 10^8 \cdot \Omega\text{Hz}} - 1} = 8,4\text{k}\Omega$$

Selected value: R22= 8,2k

Set resistor R23 for preheating time, at a projected preheating time of 900ms:

$$R_{23} = R_{TPH} = \frac{T_{PH}[\text{ms}]}{(112\text{ms})/(\text{k}\Omega)} = \frac{900\text{ms}}{(112\text{ms})/(\text{k}\Omega)} = 8,93\text{k}\Omega$$

Selected value: R23= 8,2k

Gate drive resistors R16, R26, R27 are recommended to be equal or higher than 10Ohm.

Shunt resistors R24, R25:

The selected lamp type 54W-T5 requires an ignition voltage of $V_{IGN} = 800\text{V}$ peak. In our application example the resonant inductor is evaluated to $L_2 = 1,46\text{mH}$ and the resonant capacitor $C_{20} = 4,7\text{nF}$. With this inputs we can calculate the ignition frequency f_{IGN} :

$$f_{IGN} = \sqrt{\frac{1 \pm \frac{V_{BUS} \cdot 2}{\pi \cdot V_{IGN}}}{4 \cdot \pi^2 \cdot L_2 \cdot C_{20}}} = \sqrt{\frac{1 \pm \frac{410\text{V} \cdot 2}{\pi \cdot 800\text{V}}}{4 \cdot \pi^2 \cdot 1,46\text{mH} \cdot 4,7\text{nF}}} = 69759\text{Hz}$$

The second solution of this equation (with the minus sign) leads to a result of 50163Hz, which is on the capacitive side of the resonant rise. This value is no solution, because the operating frequency approaches from the higher frequency level.

In the next step we can calculate the current through the resonant capacitor C20 when reaching a voltage level of 800V peak.

$$I_{C20} = V_{IGN} \cdot 2 \cdot \pi \cdot f_{IGN} \cdot C_{20} = 800\text{V} \cdot 2 \cdot \pi \cdot 69759\text{Hz} \cdot 4,7\text{nF} = 1,65\text{A}$$

Finally the resistors R24, R25 can be calculated from I_{C20} and the current limitation threshold during ignition mode.

$$\frac{R_{24} \cdot R_{25}}{R_{24} + R_{25}} = \frac{V_{LSCSLIMIT}}{I_{C20}} = \frac{0,8\text{V}}{1,65\text{A}} = 0,485\Omega$$

Selected values are R24= 0,82Ohm; R25= 0,82Ohm.

Lamp voltage sense resistors R31, R32, R33:

The selected lamp type 54W-T5 has a typical run voltage of 167V peak. We decide to set the EOL-thresholds at a level of 1,5 times the run voltage level (= 250,5V peak).

$$R_{31} + R_{32} + R_{33} = \frac{V_{LEOL}}{I_{LVSEOL}} = \frac{250,5V}{215\mu A} = 1165k\Omega$$

Selected values: R31= 390k; R32= 390k; R33= 390k (=1170k).

Current source resistors R34, R35 for detection of high-side filament:

$$R_{34} + R_{35} = \frac{V_{INMIN}}{I_{LVSSINKMAX}} - (R_{31} + R_{32} + R_{33}) = \frac{200V}{26\mu A} - (1170k) = 6522k\Omega$$

Selected values: R34= 2,2M; R35= 2,2M;

Current limitation resistor R30 for floating bootstrap capacitor C14:

A factor of 2 is provided in order to keep current level significant below LSCS turn-off threshold.

$$R_{30} \geq \frac{2 \cdot V_{CCON}}{V_{LSCSOVC}} \cdot \frac{R_{24} \cdot R_{25}}{R_{24} + R_{25}} = \frac{2 \cdot 14V}{1,6V} \cdot \frac{0,82 \cdot 0,82}{0,82 + 0,82} = 7,18\Omega$$

Selected value: R30= 10Ohm.

Low-side filament sense resistor R36:

For a single lamp ballast

$$R_{36} \leq \frac{V_{RESC1MIN}}{I_{RES3MIN}} = \frac{1,55V}{27,0\mu A} = 57,4k\Omega$$

Selected value: R36= 56k

$$R_{36A} \geq \frac{V_{RESC1MAX}}{I_{RES3MAX}} = \frac{1,65V}{15,1\mu A} = 109,3k\Omega$$

Selected values in a topology with 2 lamps in parallel: R36A= 110k; R36B= 110k.

Low pass filter capacitor C19:

Capacitor C19 provides a low pass filter together with resistor R36 in order to suppress AC voltage drop at the low-side filament. When we estimate an AC voltage of 10V peak-to-peak at low-side filament during run mode at $f_{RUN} = 40kHz$, we need a suppression of at least a factor $F_{LP} = 100$ (-40dB).

$$C_{19} = \sqrt{\frac{F_{LP}^2 - 1}{(2 \cdot \pi \cdot f_{RUN} \cdot R_{36})}} = \sqrt{\frac{100^2 - 1}{(2 \cdot \pi \cdot 40kHz \cdot 56k)}} = 7,1nF$$

Selected value for better ripple suppression: C19= 22nF.

Detection of capacitive mode operation via C18:

The DC level at pin RES is set by R36 and the source current I_{RES3} . The preferred AC level is in the range between $\Delta V_{ACRES} = 1,5V$ to $2,0V$ at a $\Delta V_{BUS} = 410V$.

$$C_{18} = C_{19} \cdot \frac{\Delta V_{ACRES}}{\Delta V_{BUS}} = 22nF \cdot \frac{2V}{410V} = 107pF$$

Selected value: C18= 82pF.

Bandpass filters L21/C21 and L22/C22 can be used in order to conduct filament currents preferred at preheating frequency and to suppress these currents during run mode.

Inductor L1 of the boost converter:

The inductivity of the boost inductor typically is designed to operate within a specified voltage range above a minimum frequency in order to get an easier RFI suppression. It is well known, that in critical conduction mode (CritCM) there is a minimum operating frequency at low input voltages and another minimum at maximum input voltage. In state-of-the-art CritCM PFC controllers we use the lowest value out of these two criterias:

At minimum AC input voltage:

$$L_A = \frac{(V_{INACMIN} \cdot \sqrt{2})^2 \cdot (V_{BUS} - (V_{INACMIN} \cdot \sqrt{2})) \cdot \eta}{4 \cdot F_{MIN} \cdot P_{OUTPFC} \cdot V_{BUS}}$$

$$L_A = \frac{(180V \cdot \sqrt{2})^2 \cdot (410V - (180V \cdot \sqrt{2})) \cdot 0,95}{4 \cdot 25kHz \cdot 60W \cdot 410V} = 3,89mH$$

At maximum AC input voltage

$$L_B = \frac{(V_{INACMAX} \cdot \sqrt{2})^2 \cdot (V_{BUS} - (V_{INACMAX} \cdot \sqrt{2})) \cdot \eta}{4 \cdot F_{MIN} \cdot P_{OUTPFC} \cdot V_{BUS}}$$

$$L_B = \frac{(270V \cdot \sqrt{2})^2 \cdot (410V - (270V \cdot \sqrt{2})) \cdot 0,95}{4 \cdot 25kHz \cdot 60W \cdot 410V} = 1,58mH$$

With the new control principle for the PFC preconverter we have a third criteria that covers the maximum on-time $t_{PFCOM-MAX} = 23,5\mu s$:

$$L_C = \frac{(V_{INACMIN} \cdot \sqrt{2})^2 \cdot T_{ONMAX} \cdot \eta}{4 \cdot P_{OUTPFC}}$$

$$L_C = \frac{(180 \cdot \sqrt{2})^2 \cdot 23,5\mu s \cdot 0,95}{4 \cdot 60W} = 6,03mH$$

With the assumed conditions the lowest value out of L_A , L_B , L_C is 1,58mH.

Selected value: L1= 1,58mH.

Application Examples

Bill of material for the application circuit of figure 17 and the design equations standing ahead. This design was used as an evaluation board.

Table 1 Bill of Material for a FL-Ballast of a 54W-T5 Lamp

F1	Fuse 1A fast		C17	150nF/630V
IC1	ICB1FL02G		C18	82pF/2KV
Q1	SPP03N60C3 (600V/1,4Ω)		C19	22nF/63V
Q2	SPP03N60C3 (600V/1,4Ω)		C20	4,7nF/1600V DC
Q3	SPP03N60C3 (600V/1,4Ω)		C21	22nF/400V
D1...D4	B250C1000		C22	22nF/400V
D5	MUR160			
D6	MUR160		R11	470k
D7	UF4003		R12	470k
D8	UF4003		R13	33k
D9	BZX79C16		R14	820k
D10	BZX79C4V7			
D11	1N4007		R15	820k
L0	2x68mH/0,65A		R16	22
L1	1,58mH; EFD25/13/9		R18	2,2
	Np/Ns= 128/13		R19	2,2
L2	1,46mH; EFD25/13/9		R20	10k
	Np/Ns= 153/4		R21	11,0k (45,5kHz)
L21	100μH;		R22	8,2k (106,4kHz)
L22	100μH;		R23	8,2k (918ms)
C01	220nF/X2/275V AC		R24	0,82
C02	220nF/X2/275V AC		R25	0,82
C03	3,3nF/Y1/400V AC		R26	22
C10	10μF/450V DC		R27	22
C11	2,2nF/63V		R30	10
C12	470nF/63V		R31	390k
C13	470nF/63V		R32	390k
C14	100nF/63V		R33	390k
C15	150nF/630V		R34	2,2M
C16	1nF/1kV		R35	2,2M
			R36	56k

7.3 Multilamp Ballast Topologies

How to use ICB1FL02G in multi-lamp topologies is demonstrated in the subsequent figures. In figure 18 we see an application for a single lamp with current mode preheating. Compared with figure 17 the difference is the connection of the resonant capacitor in series with the filaments. In respect of operating behaviour the current mode preheating cannot be designed with same variation of operating parameters: the preheating current is typically lower and lamp voltage during preheating higher than in topologies with voltage mode preheating.

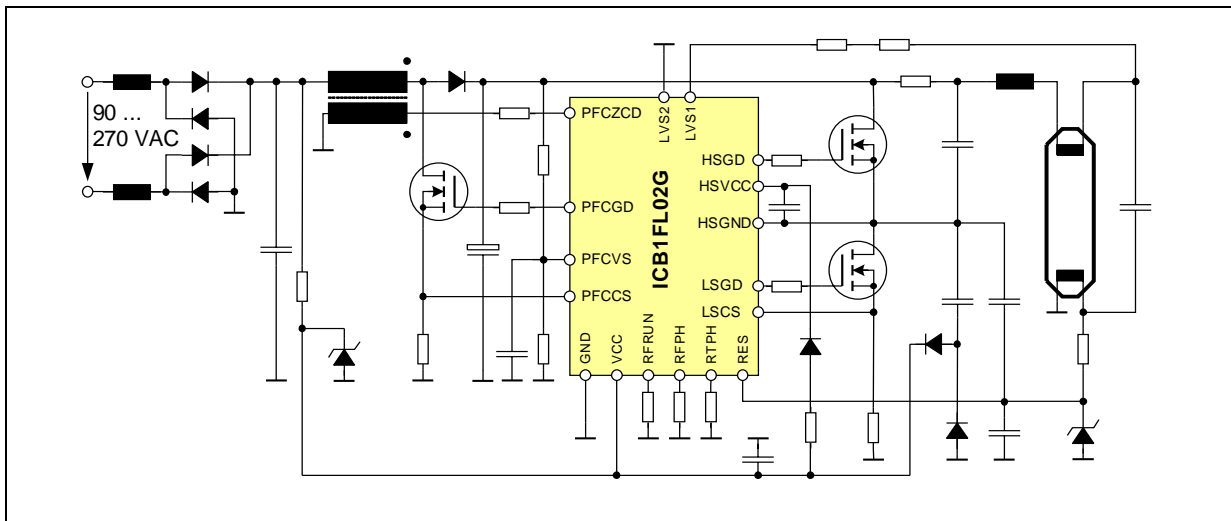

Figure 18 Application Circuit of a Ballast for a single Fluorescent Lamp with current mode Preheating.

A topology for two lamps is shown in figure 19. Both lamps including their individual resonant circuit are operating in parallel at the same inverter output. Such a topology can be done with voltage mode preheating in the same way. As the control IC is designed to operate such a 2-lamp topology without restrictions in respect to the monitoring functions, the IC-specific effort is to activate the second lamp voltage sense (LVS2) and an additional resistor at pin RES in order to sense the lamp removal of the second low-side filament.

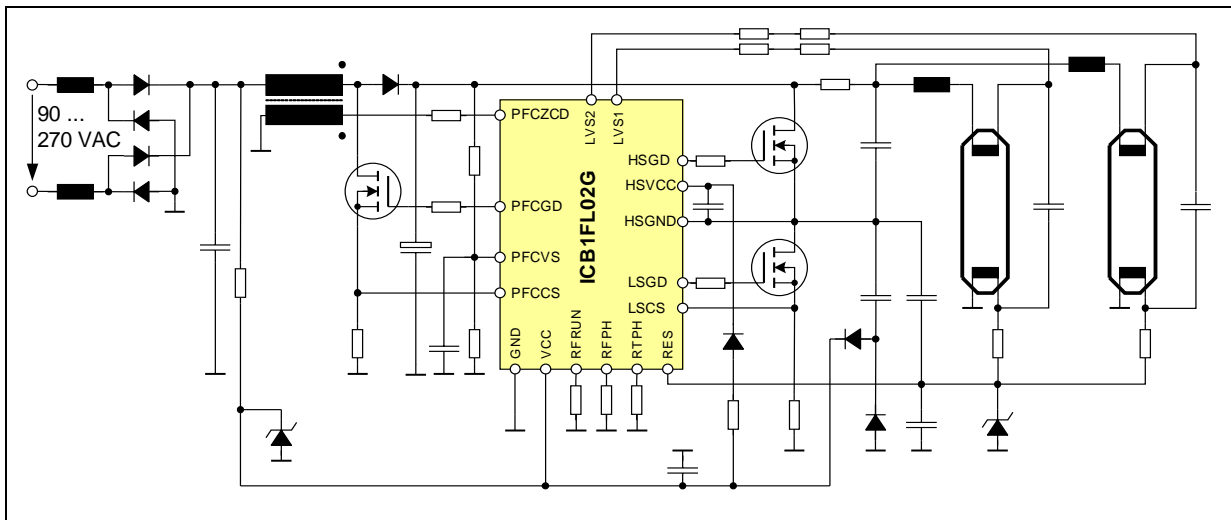

Figure 19 Application circuit of a Ballast for two Fluorescent Lamps in parallel with current mode Preheating.

Beside a topology with paralleled lamps it is possible of course to use two lamps in series. In this way we come to a 4-lamp topology shown in figure 20. The lamp voltage is sensed of each of the two series connections. The lamp removal is detected on the high-side filaments of the high-side lamps and on the low-side filaments of the

low-side lamps. In this way ICB1LB02G supports multi-lamp topologies with all required monitoring functions with a low number of external components.

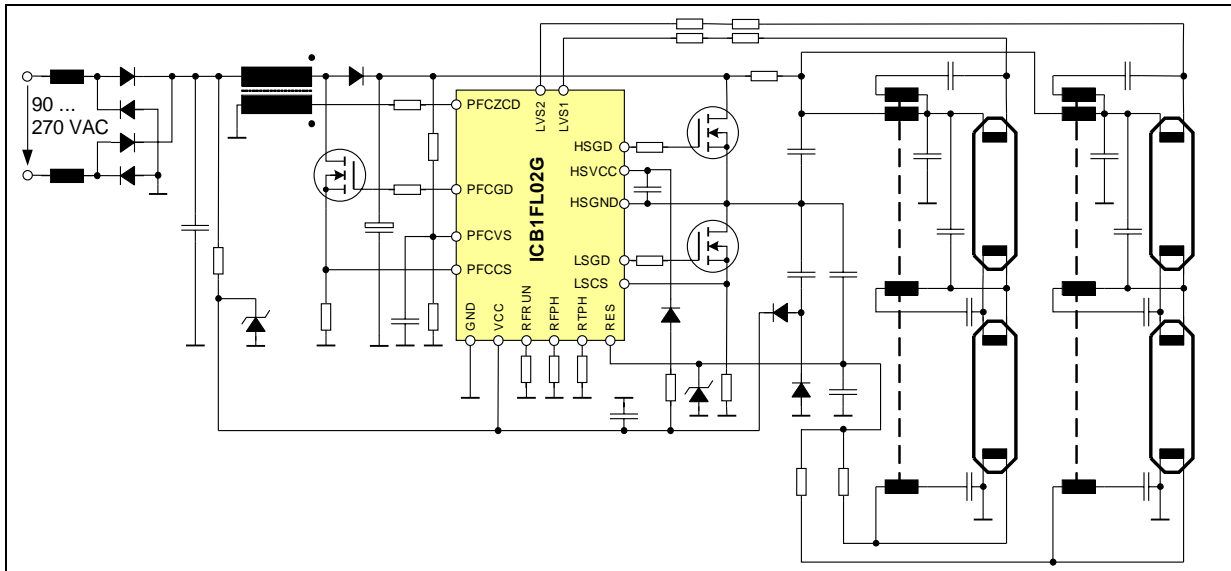

Figure 20 Application circuit of a Ballast for four Fluorescent Lamps with voltage mode Preheating.

8 Package Outlines

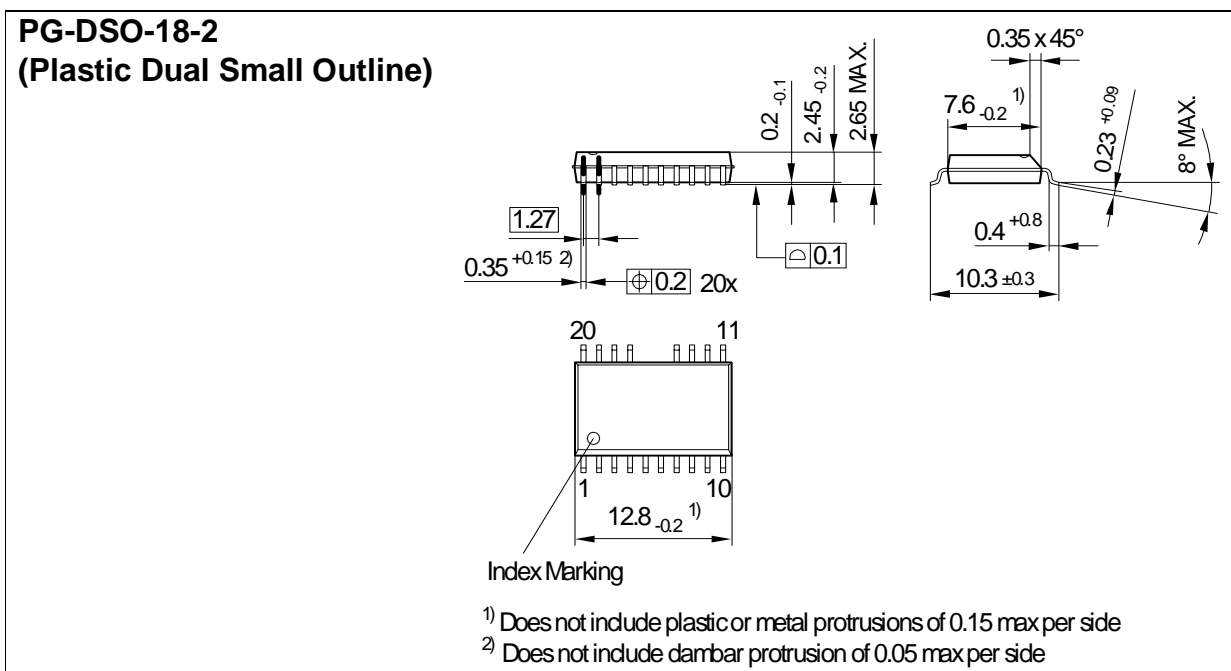

Figure 21 Package dimensions and mechanical data (Dimensions in mm).

Total Quality Management

Qualität hat für uns eine umfassende Bedeutung. Wir wollen allen Ihren Ansprüchen in der bestmöglichen Weise gerecht werden. Es geht uns also nicht nur um die Produktqualität – unsere Anstrengungen gelten gleichermaßen der Lieferqualität und Logistik, dem Service und Support sowie allen sonstigen Beratungs- und Betreuungsleistungen.

Dazu gehört eine bestimmte Geisteshaltung unserer Mitarbeiter. Total Quality im Denken und Handeln gegenüber Kollegen, Lieferanten und Ihnen, unserem Kunden. Unsere Leitlinie ist jede Aufgabe mit „Null Fehlern“ zu lösen – in offener Sichtweise auch über den eigenen Arbeitsplatz hinaus – und uns ständig zu verbessern.

Unternehmensweit orientieren wir uns dabei auch an „top“ (Time Optimized Processes), um Ihnen durch größere Schnelligkeit den entscheidenden Wettbewerbsvorsprung zu verschaffen.

Geben Sie uns die Chance, hohe Leistung durch umfassende Qualität zu beweisen.

Wir werden Sie überzeugen.

Quality takes on an all encompassing significance at Semiconductor Group. For us it means living up to each and every one of your demands in the best possible way. So we are not only concerned with product quality. We direct our efforts equally at quality of supply and logistics, service and support, as well as all the other ways in which we advise and attend to you.

Part of this is the very special attitude of our staff. Total Quality in thought and deed, towards co-workers, suppliers and you, our customer. Our guideline is “do everything with zero defects”, in an open manner that is demonstrated beyond your immediate workplace, and to constantly improve.

Throughout the corporation we also think in terms of Time Optimized Processes (top), greater speed on our part to give you that decisive competitive edge.

Give us the chance to prove the best of performance through the best of quality – you will be convinced.

<http://www.infineon.com>

Published by Infineon Technologies AG