

## IRS2573D HID BALLAST CONTROL IC

Datasheet

### Features

- Buck, full-bridge and lamp control in one IC
- Continuous/critical-conduction mode buck control
- 600V high and low-side full-bridge driver
- 600V high-side buck Driver
- Low-side ignition FET gate driver
- Integrated bootstrap FETs for full-bridge high-side drivers
- Constant lamp power control
- Programmable buck cycle-by-cycle over-current protection
- Programmable buck output voltage limitation
- Programmable lamp current limitation
- Programmable full-bridge frequency
- Fault latch reset input
- Programmable ignition counter (21sec/64sec typical)
- Programmable lamp under-voltage fault counter (197sec typical) for short-circuit or lamp does not warm-up
- Fast transient lamp under-voltage event counter (16384 typical) for arc instability or end-of-life
- Programmable lamp over-voltage fault counter (787sec typical) for open-circuit or lamp extinguishes
- Programmable good fault reset counter (2730sec typical)
- Micro-controller compatible timing thresholds
- Internal 15.6V zener clamp diode on VCC
- Micropower startup (150µA)
- Latch immunity and ESD protection on all pins

### Product Summary

Topology	Full-Bridge & Buck
$V_{\text{OFFSET}}$	600 V
$V_{\text{OUT}}$	$V_{\text{CC}}$
$I_{\text{O+}}, I_{\text{O-}}, I_{\text{O-Buck}}$ (typical)	180mA, 260mA, 400mA
Deadtime (typical)	1.2 µs
Duty Cycle	50% ±1%

### Package Options

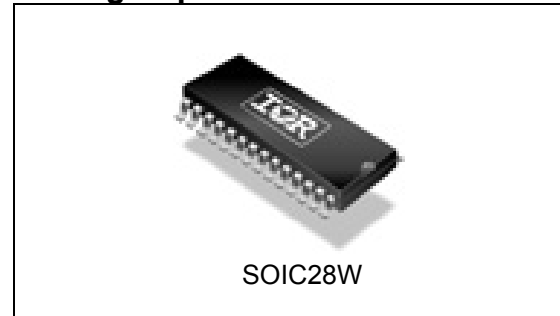

### Typical Application Diagram

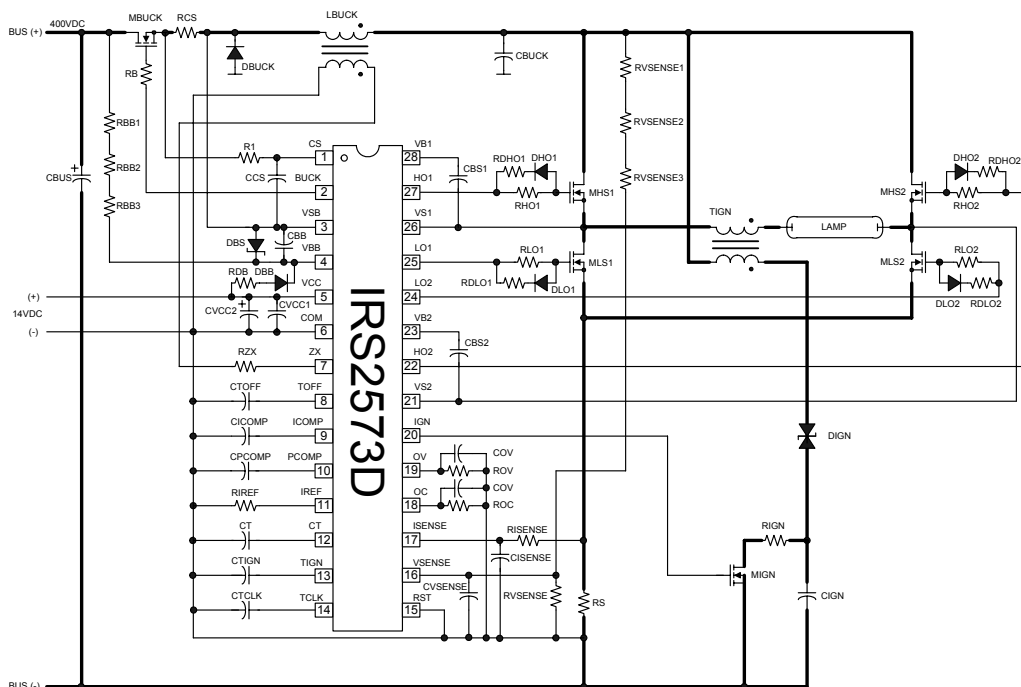

<b>Table of Contents</b>	<b>Page</b>
Typical Application Diagram	1
Qualification Information	4
Absolute Maximum Ratings	5
Recommended Operating Conditions	6
Electrical Characteristics	7
Functional Block Diagram	10
Input / output Pin Equivalent Circuit Diagram	11
Lead Definitions	12
Lead Assignments	13
State Diagram	14
Application Information and Additional Details	15
Parameter Temperature Trends	23
Package Details	25
Package Details, Tape and Reel	26
Part Marking Information	27
Ordering Information	28

## Description

The IRS2573D is a fully-integrated, fully-protected 600V HID control IC designed to drive all types of HID lamps. Internal circuitry provides control for ignition, warm-up, running and fault operating modes. The IRS2573D features include ignition timing control, constant lamp power control, programmable full-bridge running frequency, programmable over and under-voltage protection and programmable over-current protection. Advanced protection features such as failure of a lamp to ignite, open load, short-circuit and a programmable fault counter have also been included in the design.

**Qualification Information<sup>†</sup>**

<b>Qualification Level</b>		Industrial <sup>††</sup>	
		Comments: This family of ICs has passed JEDEC's Industrial qualification. IR's Consumer qualification level is granted by extension of the higher Industrial level.	
<b>Moisture Sensitivity Level</b>		SOIC28W	MSL3 <sup>†††</sup> 260°C (per IPC/JEDEC J-STD-020)
<b>ESD</b>	Machine Model	Class B (per JEDEC standard JESD22-A115)	
	Human Body Model	Class 2 (per EIA/JEDEC standard EIA/JESD22-A114)	
<b>IC Latch-Up Test</b>		Class I, Level A (per JESD78)	
<b>RoHS Compliant</b>		Yes	

† Qualification standards can be found at International Rectifier's web site <http://www.irf.com/>

†† Higher qualification ratings may be available should the user have such requirements. Please contact your International Rectifier sales representative for further information.

††† Higher MSL ratings may be available for the specific package types listed here. Please contact your International Rectifier sales representative for further information.

### Absolute Maximum Ratings

Absolute maximum ratings indicate sustained limits beyond which damage to the device may occur. All voltage parameters are absolute voltages referenced to COM, all currents are defined positive into any lead. The thermal resistance and power dissipation ratings are measured under board mounted and still air conditions.

Symbol	Definition	Min.	Max.	Units	
VB1	High-Side Floating Supply Voltage	-0.3	625	V	
VB2	High-Side Floating Supply Voltage	-0.3	625		
VBB	High-Side Floating Supply Voltage	-0.3	625		
VS1	High-Side Floating Supply Offset Voltage	VB1 - 25	VB1 + 0.3		
VS2	High-Side Floating Supply Offset Voltage	VB2 - 25	VB2 + 0.3		
VSB	High-Side Floating Supply Offset Voltage	VBB - 20	VBB + 0.3		
VHO1	High-Side Floating Output Voltage	VS1 - 0.3	VB1 + 0.3		
VHO2	High-Side Floating Output Voltage	VS2 - 0.3	VB2 + 0.3		
VBUCK	High-Side Floating Output Voltage	VSB - 0.3	VBB + 0.3		
VLO1	Low-Side Output Voltage	-0.3	VCC + 0.3		
VLO2	Low-Side Output Voltage	-0.3	VCC + 0.3		
VIGN	Low-Side Output Voltage	-0.3	VCC + 0.3		
VCS	Buck Current Sense Pin Voltage	VSB - 0.3	VBB + 0.3		
VCT	Full-Bridge Oscillator Timing Pin Voltage	-0.3	VCC + 0.3		
VTIGN	Ignition Timer Pin Voltage	-0.3	VCC + 0.3		
VTCLK	Fault Timer Pin Voltage	-0.3	VCC + 0.3		
VRST	Reset Pin Voltage	-0.3	VCC + 0.3		
VVSENSE	Lamp Voltage Sense Pin Voltage	-0.3	VCC + 0.3		
VISENSE	Lamp Current Sense Pin Voltage	-0.3	VCC + 0.3		
VOC	Current Limitation Pin Voltage	-0.3	VCC + 0.3		
VOV	Voltage Limitation Pin Voltage	-0.3	VCC + 0.3		
IOMAX	Maximum allowable output current (HO1, HO2, BUCK, LO1, LO2, IGN) due to external power transistor miller effect	-500	500	mA	
IBB	Buck High-side Supply Current	-20	20		
ICS	Buck Current Sense Pin Current	-5	5		
IICOMP	Buck Compensation Pin Current	-5	5		
IPCOMP	Buck Compensation Pin Current	-5	5		
IZX	Buck Zero-crossing Detection Pin Current	-5	5		
ITOFF	Buck Off-time Pin Current	-5	5		
ICC	Supply current <sup>†</sup>	-20	20		
IREF	Current Reference Pin Current	-5	5		
dV <sub>S</sub> /dt	Allowable offset voltage slew rate	-50	50		V/ns
P <sub>D</sub>	Package power dissipation @ T <sub>A</sub> ≤ +25 °C	SOIC28W	---	1.6	W
R <sub>ΘJA</sub>	Thermal resistance, junction to ambient	SOIC28W	---	78	°C/W
T <sub>J</sub>	Junction temperature	---	-55	150	°C
T <sub>S</sub>	Storage temperature	---	-55	150	
T <sub>L</sub>	Lead temperature (soldering, 10 seconds)	---	---	300	

† This IC contains a voltage clamp structure between the chip V<sub>CC</sub> and COM which has a nominal breakdown voltage of 15.6 V. Please note that this supply pin should not be driven by a DC, low impedance power source greater than the V<sub>CLAMP</sub> specified in the Electrical Characteristics section.

**Recommended Operating Conditions**

For proper operation the device should be used within the recommended conditions.

Symbol	Definition	Min.	Max.	Units
VB1-VS1	High Side Floating Supply Voltage	VB1UV+	VCLAMP1	V
VB2-VS2	High Side Floating Supply Voltage	VB2UV+	VCLAMP1	
VBB-VSB	High Side Floating Supply Voltage	VBBUV+	VCLAMP1	
VS1,VS2,VS B	Steady State High-side Floating Supply Offset Voltage	-1 <sup>†</sup>	600	
VCC	Supply Voltage	VCCUV+	VCLAMP1	
ICC	VCC Supply Current	††	10	mA
IBB	VBB Supply Current	†††	10	
ICS	Buck Current Sensing Pin Current	-1	1	
IZX	Buck Zero-crossing Sensing Pin Current	-1	1	
CTOFF	Buck Off-time Pin Capacitor	470	---	
CT	Full-bridge Oscillator Timing Pin Capacitor	10	---	nF
CTIGN	Ignition Timer Pin Capacitor	10	---	
CTCLK	Fault Counter Pin Capacitor	10	---	
RIREF	Current Reference Pin Resistor	10	---	kOhm
VRST	Reset Pin Voltage	0	VCC	V
VVSENSE	Voltage Sense Pin Voltage	0	VCC	
VISENSE	Current Sense Pin Voltage	0	VCC	
VOC	Current Limitation Pin Voltage	0	VCC	
VOV	Voltage Limitation Pin Voltage	0	VCC	
TJ	Junction Temperature	-40	125	

- † Care should be taken to avoid output switching conditions where the VS node flies inductively below ground by more than 5 V.
- †† Enough current should be supplied to the V<sub>CC</sub> pin to keep the internal 15.6 V zener diode clamping the voltage at this pin.
- ††† Enough current should be supplied to the V<sub>BB</sub> pin to maintain a V<sub>BBSB</sub> voltage magnitude of VCLAMP1.

**Electrical Characteristics**

VCC = VB1S1 = VB2S2 = VBBSB = VBIAS = 14V +/- 0.25V, CLO1 = CLO2 = CIGN = CHO1 = CHO2 = BUCK = 1000pF, RIREF = 20kOhm, ROC = 10kOhm, ROV = 50kOhm, VRST = COM, CS = VSB, CT = TIGN = TCLK = VSENSE = ISENSE = PCOMP = ICOMP = ZX = TOFF = COM, TA = 25C unless otherwise specified.

Symbol	Definition	Min	Typ	Max	Units	Test Conditions
<b>Supply Characteristics</b>						
VCCUV+	VCC Supply Undervoltage Positive Going Threshold	9.5	10.5	11.5	V	VCC rising from 0V
VCCUV-	VCC Supply Undervoltage Negative Going Threshold	8.5	9.5	10.5		VCC falling from 14V
VUVHYS	VCC Supply Undervoltage Lockout Hysteresis	0.5	1.0	1.5		
IQCCUV	UVLO Mode VCC Quiescent Current	---	150		µA	VCC = 9V
IQCCFLT	Fault Mode VCC Quiescent Current	---	420			
IQCC	Quiescent VCC Supply Current	---	3.5	---	mA	
ICCGM	General Mode VCC Supply Current	---	5.0	---		VICOMP = VPCOMP = 4V, CTOFF=1nF, CT=47nF, CTIGN=1µF, CTCLK=0.12µF, VSENSE=0.8V
VCLAMP1	VCC Zener Clamp Voltage	14.6	15.6	16.6	V	ICC = 10mA
<b>Full-Bridge Floating Supply Characteristics</b>						
IQB1S1_0	Quiescent VBS Supply Current	---	50	---	µA	VHO1 = VS1
IQB1S1_1	Quiescent VBS Supply Current	---	80	---		VHO1 = VB1
VB1S1UV+	VB1S1 Supply Undervoltage Positive Going Threshold	8.0	9.0	10.0	V	VB1S1 rising from 0V
VB1S1UV-	VB1S1 Supply Undervoltage Negative Going Threshold	7.0	8.0	9.0		VB1S1 falling from 14V
ILKVS1	VS1 Offset Supply Leakage Current	---	---	50	µA	VB1 = VS1 = 600V
IQB2S2_0	Quiescent VBS Supply Current	---	50	---		VHO2 = VS2
IQB2S2_1	Quiescent VBS Supply Current	---	80	---		VHO2 = VB2
VB2S2UV+	VB2S2 Supply Undervoltage Positive Going Threshold	8.0	9.0	10.0	V	VB2S2 rising from 0V
VB2S2UV-	VB2S2 Supply Undervoltage Negative Going Threshold	7.0	8.0	9.0		VB2S2 falling from 14V
ILKVS2	VS2 Offset Supply Leakage Current	---	---	50	µA	VB2 = VS2 = 600V
<b>Buck Floating Supply Characteristics</b>						
VCLAMP2	VBB Zener Clamp Voltage	19.8	20.8	21.8	V	IBB = 10mA
IQBBSB_0	Quiescent VBBSB Supply Current	---	360		µA	VBUCK = VSB
IBBSB	VBBSB Supply Current	---	1	---	mA	VICOMP = VPCOMP = 4V, CTOFF = 1nF
VBBSBUV+	VBBSB Supply Undervoltage Positive Going Threshold	8.0	9.0	10.0	V	VBBSB rising from 0V VICOMP = VPCOMP = 0.5V
VBBSBUV-	VBBSB Supply Undervoltage Negative Going Threshold	7.0	8.0	9.0		VBBSB falling from 14V VICOMP = VPCOMP = 0.5V
ILKVSB	VSB Offset Supply Leakage Current	---	---	50	µA	VBB = VSB = 600V
VCS	CS pin over-current threshold	1.03	1.18	1.33	V	VICOMP = VPCOMP = 4V
tBLANK	CS pin current-sensing blank time	50	120	190	ns	

**Electrical Characteristics**

VCC = VB1S1 = VB2S2 = VBBSB = VBIAS = 14V +/- 0.25V, CLO1 = CLO2 = CIGN = CHO1 = CHO2 = BUCK = 1000pF, RIREF = 20kOhm, ROC = 10kOhm, ROV = 50kOhm, VRST = COM, CS = VSB, CT = TIGN = TCLK = VSENSE = ISENSE = PCOMP = ICOMP = ZX = TOFF = COM, TA = 25C unless otherwise specified.

Symbol	Definition	Min	Typ	Max	Units	Test Conditions
<b>Buck Control Characteristics</b>						
IPCOMP SOURCE	OTA1 Error Amplifier Output Current Sourcing	28	40	52	uA	VPCOMP=7V VSENSE = VISENSE = VSENSE <sub>PCOMP=0uA</sub> - 0.3V
IPCOMP SINK	OTA1 Error Amplifier Output Current Sinking	28	40	52		VPCOMP=7V VSENSE = VISENSE = VSENSE <sub>PCOMP=0uA</sub> + 0.3V
IICOMP SOURCE	OTA2 Error Amplifier Output Current Sourcing	28	40	52		VICOMP=7V VISENSE = VISENSE <sub>ICOMP=0uA</sub> - 0.5V
IICOMP SINK	OTA2 Error Amplifier Output Current Sinking	28	40	52		VICOMP=7V VISENSE = VISENSE <sub>ICOMP=0uA</sub> + 0.5V
VCOMPOH	OTA1,2 Error Amplifier Output Voltage Swing (high state)	---	12.5	---	V	IPCOMP = IPCOMP_SOURCE - 10uA, or IICOMP = IICOMP_SOURCE - 10uA
KMULT	Internal Multiplier Gain $K_{MULT} = VIREF / ( 2x VVSENSE x VISENSE )$	---	2.0	---		VVSENSE = VVSENSE <sub>(PCOMP = 0uA)</sub> , VISENSE = 500mV
PSENSE	VVSENSE x VISENSE	0.465	0.50	0.535		VVSENSE = 1V VISENSE = 500mV
VPCOMP <sub>TH</sub>	PCOMP pin buck on/off threshold voltage	---	0.2	---	V	VICOMP = 2V
VICOMP <sub>TH-</sub>	ICOMP pin buck off threshold voltage	---	0.2	---		VPCOMP = 2V
VICOMP <sub>TH+</sub>	ICOMP pin buck on threshold voltage	---	0.5	---		VPCOMP = 2V
VZX	ZX pin Comparator Threshold Voltage	---	2.0	---		VPCOMP = VICOMP = 7V
VZX <sub>hys</sub>	ZX pin Comparator Hysteresis	---	400	---	mV	VPCOMP = VICOMP = 7V
VZX <sub>clamp</sub>	ZX pin Clamp Voltage (high state)	---	6.5	---	V	IZX = 5mA
ITOFF	TOFF pin Output Current	91	110	129	uA	VBUCK = VSB
VTOFF	TOFF pin Comparator Threshold Voltage	1.93	2.05	2.17	V	VPCOMP = VICOMP = 7V CTOFF = 1nF
<b>Full-Bridge Oscillator Characteristics</b>						
fOSC	Full-Bridge oscillator frequency	160	200	240	Hz	CCT = 47nF
d	Oscillator duty cycle	49	50	51	%	
td <sub>LO1,2</sub>	LO1, LO2 output deadtime	0.8	1.2	1.5	us	
td <sub>HO1,2</sub>	HO1, HO2 output deadtime	0.8	1.2	1.5		
VCT+	CT pin upper threshold voltage	---	4.0	---	V	
VCT-	CT pin lower threshold voltage	---	2.0	---		
ICT SOURCE	CT pin sourcing current	---	80	---	uA	VCT = 1.5V
ICT SINK	CT pin sinking current	---	80	---		VCT = 4.5V
<b>Ignition Timer Characteristics</b>						
TIGNON	IGN pin on-time	18	21	24	sec	CTIGN = 1uF MODE = IGN
TIGNOFF	IGN pin off-time	57	64	71		
VTIGN+	TIGN pin upper threshold voltage	---	4.0	---	V	
VTIGN-	TIGN pin lower threshold voltage	---	2.0	---		
ITIGN SOURCE	TIGN pin sourcing current	---	6	---	uA	VTIGN = 1.5V
ITIGN SINK	TIGN pin sinking current	---	6	---		VTIGN = 4.5V



**Electrical Characteristics**

VCC = VB1S1 = VB2S2 = VBBSB = VBIAS = 14V +/- 0.25V, CLO1 = CLO2 = CIGN = CHO1 = CHO2 = BUCK = 1000pF, RIREF = 20kOhm, ROC = 10kOhm, ROV = 50kOhm, VRST = COM, CS = VSB, CT = TIGN = TCLK = VSENSE = ISENSE = PCOMP = ICOMP = ZX = TOFF = COM, TA = 25C unless otherwise specified.

Symbol	Definition	Min	Typ	Max	Units	Test Conditions
<b>Fault Counter Characteristics</b>						
TCLK	CLK pin oscillation period	---	12.0	---	ms	CTCLK = 0.12uF
VTCLK+	TCLK pin upper threshold voltage	---	4.0	---	V	
VTCLK-	TCLK pin lower threshold voltage	---	2.0	---		
ITCLK SOURCE	TCLK pin sourcing current	---	40	---	uA	VTCLK = 1.5V
ITCLK SINK	TCLK pin sinking current	---	40	---		VTCLK = 4.5V
tGOOD	GOOD COUNTER time	---	2850	---	sec	CTIGN = 1uF, VSENSE = 0.8V
tUVFAULT	VSENSE pin under-voltage fault counter time	187	197	207		CTCLK = 0.12uF, VSENSE < VOV(1/7.5)
tOVFAULT	VSENSE pin over-voltage fault counter time	737	787	837		CTCLK = 0.12uF, VSENSE > VOV(2/5)
nEVENTS	VSENSE pin fast transient under-voltage fault events	---	16384	---		VSENSE = pulses (ton=10us, toff=5us, ampl.= 0.8V to COM)
VRST+	RST pin rising threshold voltage	---	---	2.5	V	MODE = FAULT
VRST-	RST pin falling threshold voltage	1.5	---	---		MODE = UVLO
<b>Reference Current Characteristics</b>						
VIREF	IREF pin reference voltage	1.95	2.00	2.05	V	RIREF = 20kOhm
<b>Voltage Sensing Characteristics</b>						
VOV	VSENSE pin buck voltage limitation threshold	2.3	2.55	2.8	V	ROV = 50kOhm
VOV(2/5)	VSENSE pin over-voltage threshold	0.92	1.05	1.18		
VOV(1/7.5)	VSENSE pin under-voltage threshold	0.298	0.35	0.403		
<b>Current Limitation Characteristics</b>						
VISENSE	ISENSE pin current limitation threshold	460	520	580	mV	ROC = 10kOhm
<b>Gate Driver Output Characteristics (HO1, HO2, LO1, LO2, BUCK, IGN pins)</b>						
VOL	Low-Level output voltage	---	COM	---	V	IO = 0
VOH	High-Level output voltage	---	VCC	---		
Tr	Turn-On rise time	---	120	220	ns	
Tf	Turn-Off fall time	---	50	100		
IO+	HO1, HO2, LO1, LO2, IGN Source Current	---	180	---	mA	VICOMP = VPCOMP = 10V
IO-	HO1, HO2, LO1, LO2, IGN Sink Current	---	260	---		
IO+	BUCK Source Current	---	180	---		
IO-	BUCK Sink Current	---	400	---		
<b>Bootstrap MOSFET Characteristics (VB1, VB2 pins)</b>						
VB_ON	VB voltage when BS FET is on	13.0	13.7	---	V	
IB_CAP	VB source current when BS FET is on	---	55	---	mA	VBS=0V
IB_10V	VB source current when BS FET is on	---	12	---		VVB = 10V CT = 0V, CT = 6V

**Functional Block Diagram**

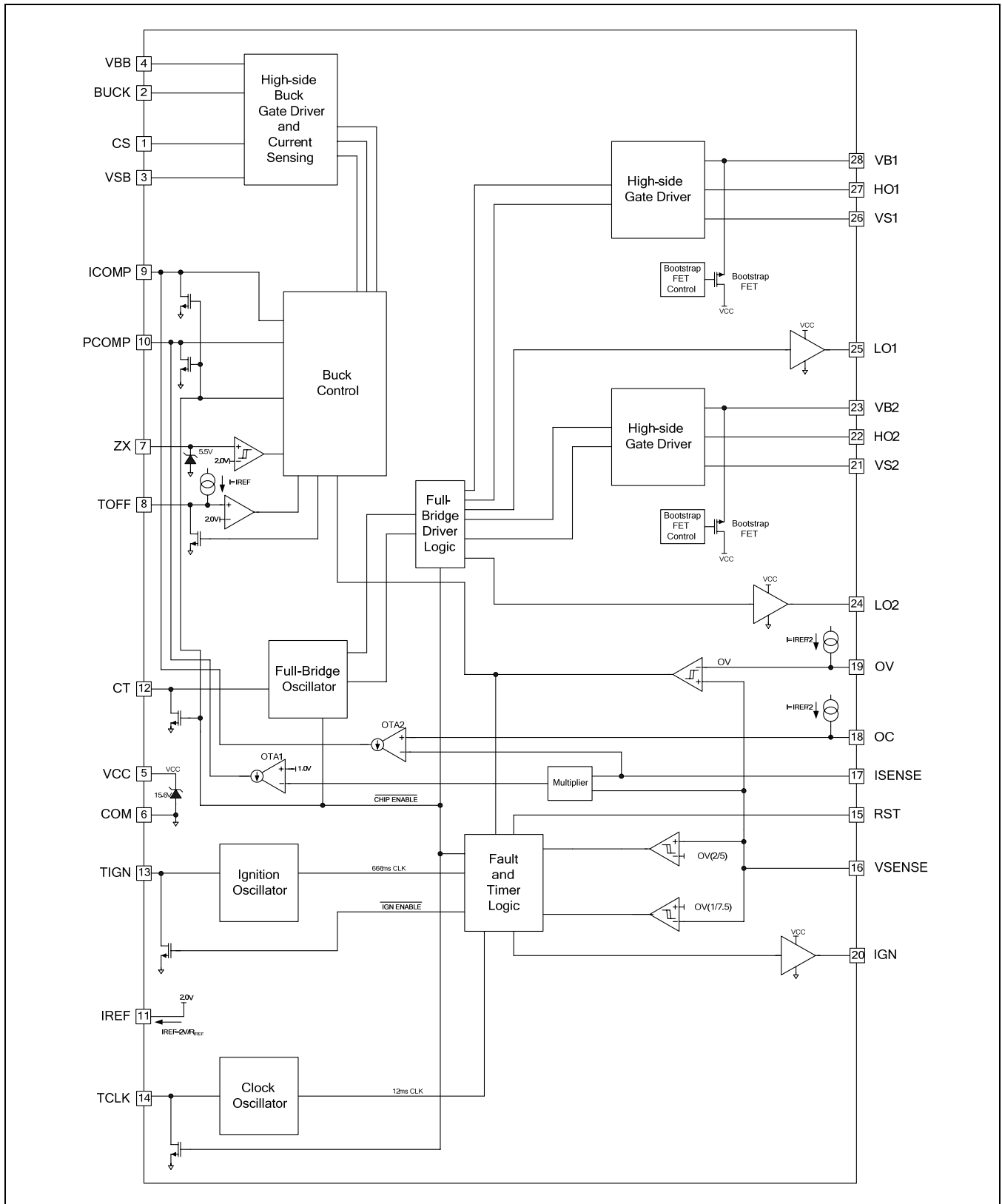

**Input/Output Pin Equivalent Circuit Diagrams: IRS2573D**

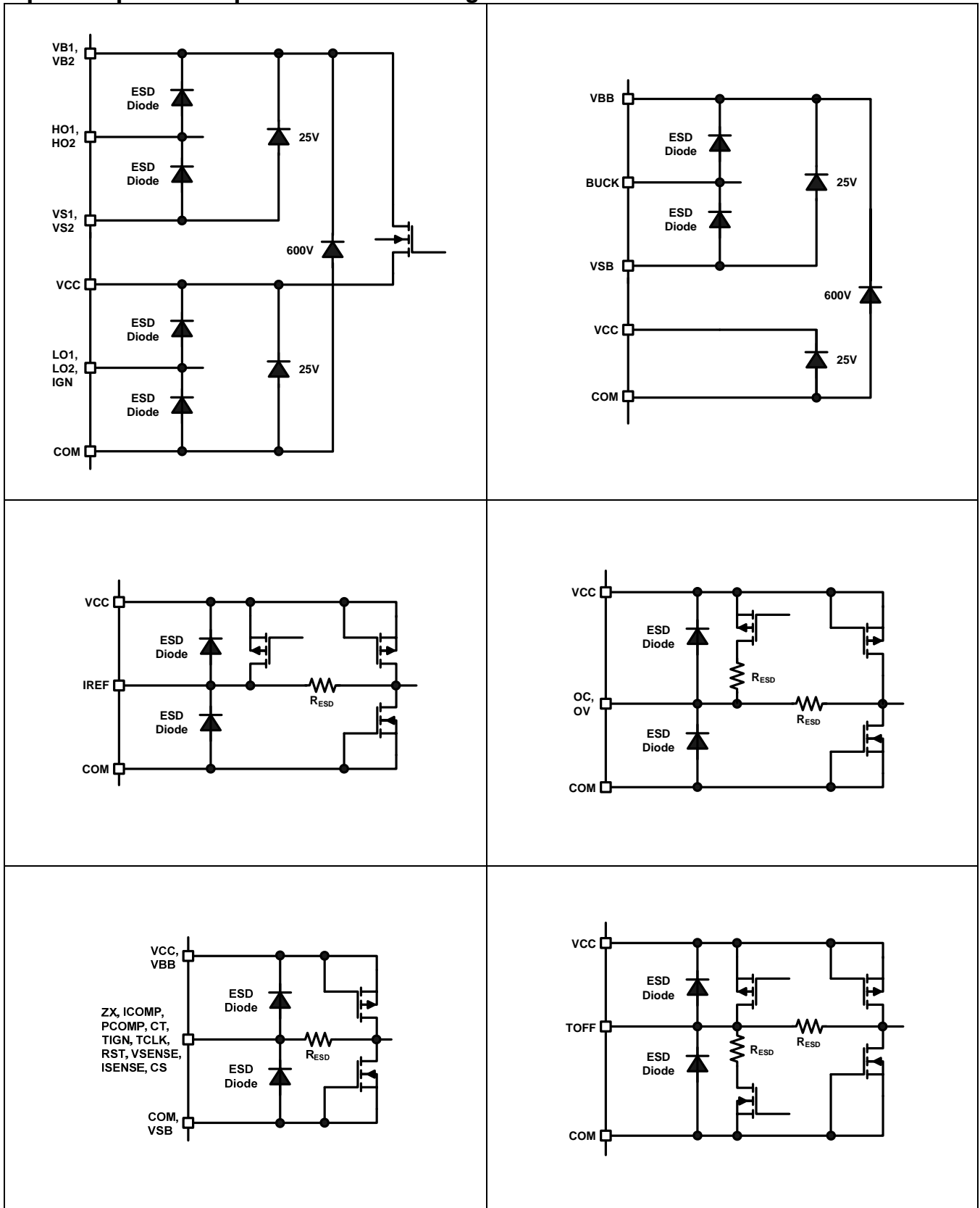

**Lead Definitions**

<b>Symbol</b>	<b>Description</b>
CS	Buck Current-sensing Input
BUCK	Buck High-side Floating Gate Driver Output
VSB	Buck High-side Floating Return
VBB	Buck High-side Floating Gate Driver Supply Voltage
VCC	IC Supply Voltage
COM	IC Power and Signal Ground
ZX	Buck Zero-Crossing Detection Input
TOFF	Buck Off-time Programming Capacitor
ICOMP	Buck On-time Current Limit Compensation Capacitor
PCOMP	Buck On-time Constant Power Compensation Capacitor
IREF	Current Reference Programming Resistor
CT	Full-Bridge Oscillator Timing Capacitor
TIGN	Ignition Timer Programming Capacitor
TCLK	Fault Timer Programming Capacitor
RST	Fault Reset Input
VSENSE	Lamp Voltage Sensing Input
ISENSE	Lamp Current Sensing Input
OV	ISENSE Over-current Threshold Programming Resistor
OV	VSENSE Over-voltage Threshold Programming Resistor
IGN	Igniter Low-side Gate Driver Output
VS2	Full-Bridge High-side Floating Return
HO2	Full-Bridge High-side Floating Gate Driver Output
VB2	Full-Bridge High-side Floating Gate Driver Supply Voltage
LO2	Full-Bridge Low-side Gate Driver Output
LO1	Full-Bridge Low-side Gate Driver Output
VS1	Full-Bridge High-side Floating Return
HO1	Full-Bridge High-side Floating Gate Driver Output
VB1	Full-Bridge High-side Floating Gate Driver Supply Voltage

**Lead Assignments**

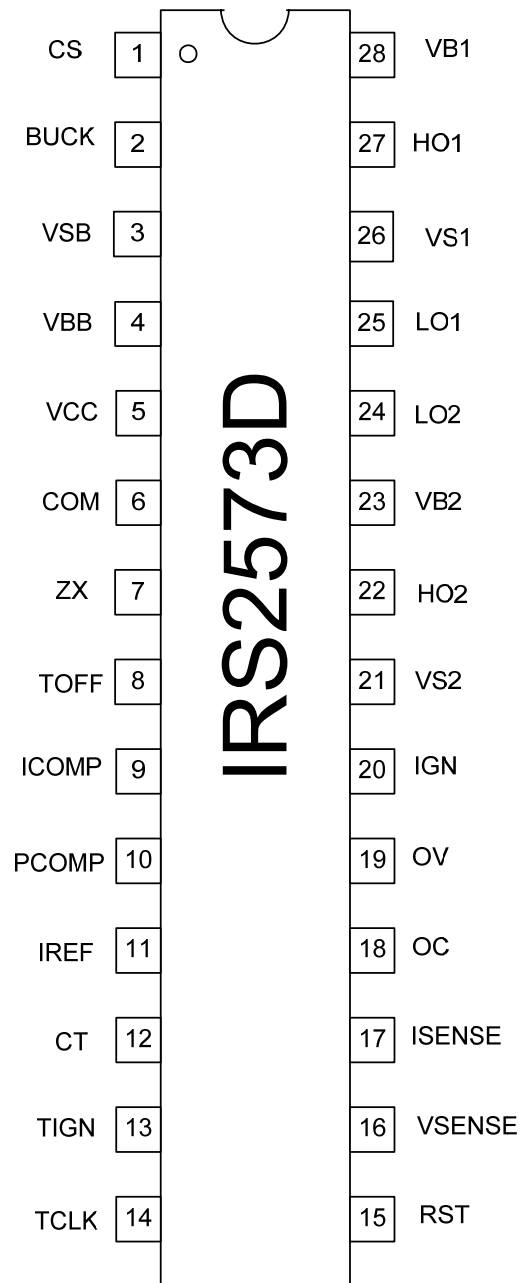

**State Diagram†**

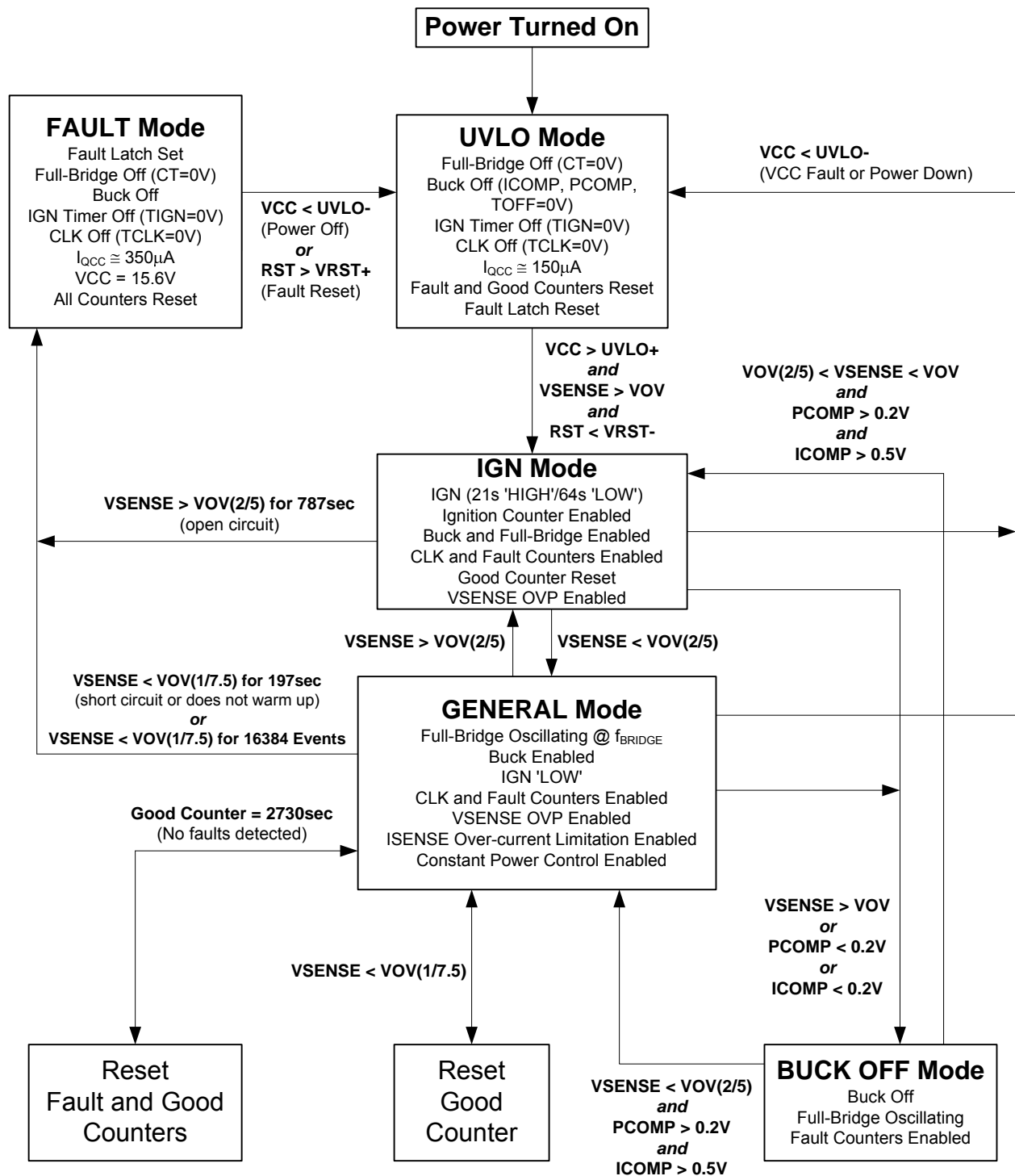

† All values are typical. Applies to application circuit on page 1.

## Application Information and Additional Details

Information regarding the following topics is included as subsections within this section of the datasheet.

- IGBT/MOSFET Gate Drive
- Undervoltage Lockout Protection
- General Mode
- Ignition Timer
- Full-Bridge Control
- Buck Control
- Constant Power Control
- Current Limitation Control
- Over Voltage Fault Counter
- Under Voltage Fault Counter
- Fast Transient Under-Voltage Fault Counter
- Good Counter
- Fault Reset
- PCB Layout Tips
- Additional Documentation

### IGBT/MOSFET Gate Drive

The IRS2573D HVICs are designed to drive up to six MOSFET or IGBT power devices. Figures 1 and 2 illustrate several parameters associated with the gate drive functionality of the HVIC. The output current of the HVIC, used to drive the gate of the power switch, is defined as  $I_O$ . The voltage that drives the gate of the external power switch is defined as  $V_{HO}$  for the high-side power switch and  $V_{LO}$  for the low-side power switch; this parameter is sometimes generically called  $V_{OUT}$  and in this case does not differentiate between the high-side or low-side output voltage.

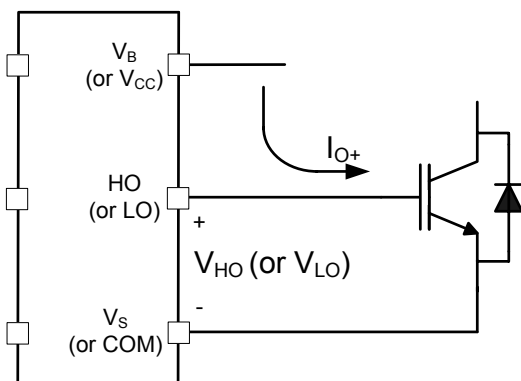

**Figure 1: HVIC sourcing current**

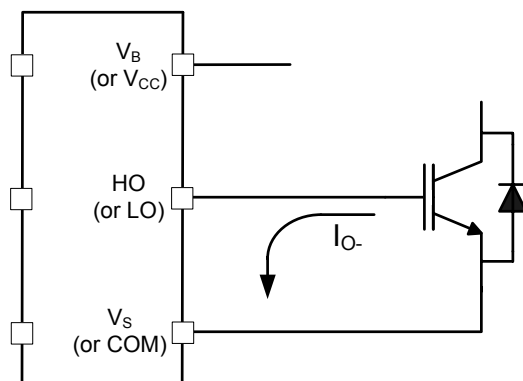
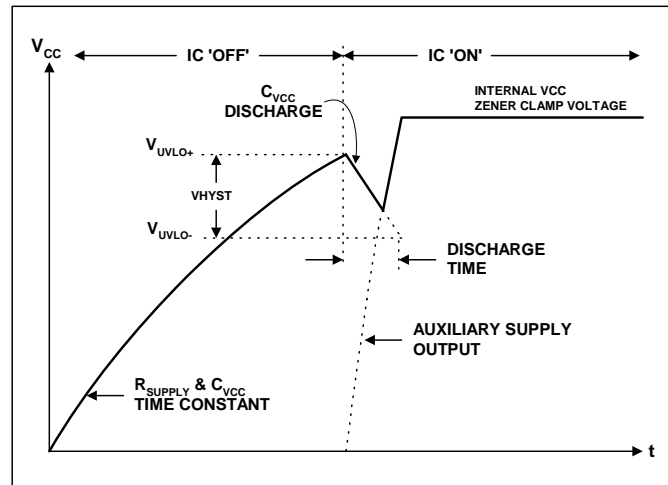

**Figure 2: HVIC sinking current**

### Undervoltage Lock-Out

The under-voltage lockout mode (UVLO) is defined as the state the IC is in when VCC is below the turn-on threshold of the IC. The IC is designed to maintain an ultra-low supply current during UVLO mode of 150uA for reducing power losses across the external start-up resistor, and, to guarantee the IC is fully functional before the buck high-side and full-bridge high and low-side output drivers are activated. The external capacitor from VCC to COM is charged by a current flowing from the rectified AC line or DC bus through an external supply resistor minus the micro-power start-up current drawn by the IC. The external start-up resistor is chosen so that VCC exceeds the IC turn-on threshold at the desired AC line turn-on voltage for the ballast. Once the capacitor voltage

on VCC reaches the start-up threshold (UVLO+), and, the voltage on RST pin is less than 1.5V, the IC turns on and the full-bridge oscillator (CT) and gate driver outputs (HO1, LO1, HO2 and LO2) begin to oscillate. The capacitor from VCC to COM begins to discharge due to the increase in IC operating current. An auxiliary supply (secondary winding, charge pump, etc.) should then take over as the main supply voltage before VCC discharges to the IC turn-off threshold (Figure 3) and charge VCC up to the internal zener clamp diode voltage (15.6V typical). During UVLO mode, the full-bridge and buck are off, the ignition timer and clock are off, the fault and good counters are reset, and the fault latch is reset.



**Figure 3, IC supply voltage during turn-on**

**General Mode**

During General Mode, the IC reacts to the different load conditions (open-circuit, short-circuit, lamp warm-up, constant power running, under-voltage lamp faults, transient under-voltage lamp faults, over-voltage lamp faults, lamp non-strike, etc.) by turning the buck circuit on or off, adjusting the buck circuit on-time, or counting the occurrence of the different fault conditions and turning the complete IC off. The IC senses the different load conditions at the VSENSE and ISENSE pins, compares the voltages at these pins against the programmed thresholds at the OV and OC pins, and determines the correct operating mode of the IC (see State Diagram).

**Ignition Timer**

The ignition timer is enabled when the IC first enters IGN Mode. The ignition timer frequency is programmed with the external capacitor at the TIGN pin. CTIGN charges up and down linearly through internal sink and source currents between a fixed voltage window of 2V and 4V (Figure 4). This sets up an internal clock (666ms typical) that is divided out 128 times and then used to turn the ignition gate driver output (IGN pin) on and off for a given on and off-time (21sec 'high'/64sec 'low' typical). A logic 'high' at the IGN pin will turn the external ignition MOSFET on and enable the external sidac-controlled pulse ignition circuit (see Figure 5, and Typical Application Diagram). The ignition circuit will continuously try to ignite the HID lamp for 21sec 'on' and 64sec 'off' until the lamp ignites. If the lamp does not ignite after 787sec then the IC will enter Fault Mode and latch off. If the lamp ignites successfully, the voltage at the VSENSE pin will fall below VOV(2/5) due to the low impedance of the lamp and the ignition timer will be disabled (logic 'low' at the IGN pin).



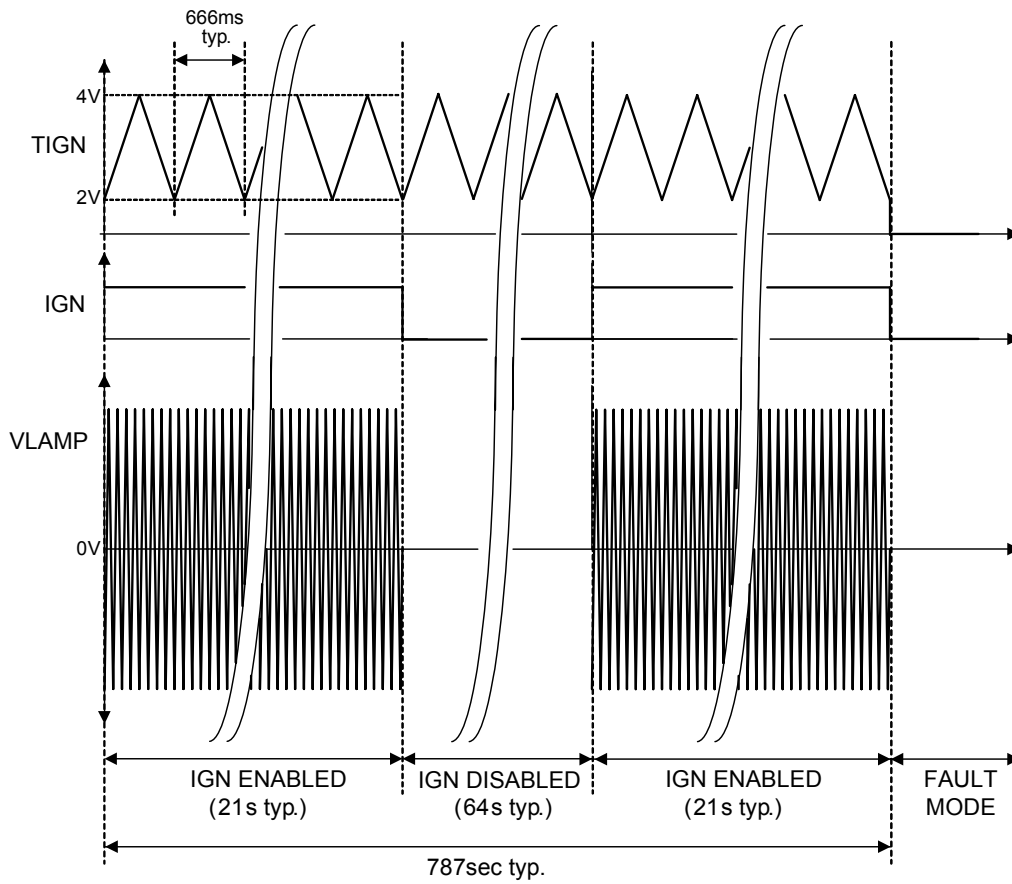

**Figure 4, Ignition timer timing diagram**

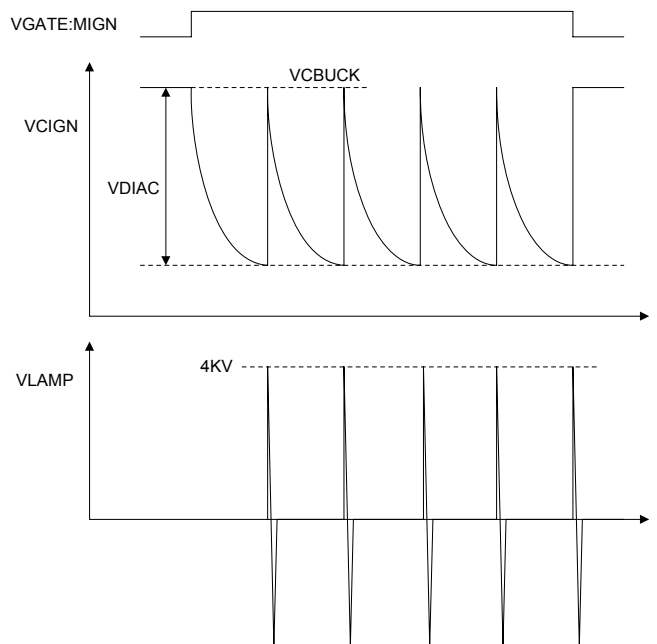

**Figure 5, Ignition circuit timing diagram.**

**Full-Bridge Control**

The IC includes a complete high and low-side full-bridge driver necessary for driving the HID lamp with an AC square-wave voltage. The full-bridge begins oscillating at the programmed frequency immediately when the IC comes out of UVLO Mode and turns on. The full-bridge is typically driven at a low frequency to prevent acoustic resonances from damaging the lamp. The full-bridge frequency is programmed with the external capacitor at the CT pin. CT charges up and down linearly through internal sink and source currents between a fixed voltage window of 2V and 4V. CT reaching 4V initiates the toggling of LO1/HO1, and LO2/HO2 respectively (see Figure 6). The dead-time is fixed internally at 1.0us typical. During the dead-time, all full-bridge MOSFETs are off and the mid-points of each half-bridge are floating or unbiased. Should an external transient occur during the dead-time due to an ignition voltage pulse, each half-bridge mid-point (VS1 and VS2 pins) can slew high or low very quickly and exceed the dv/dt rating of the IC. To prevent this, internal logic guarantees that the IGN pin is set to a logic 'low' during the dead-time. No ignition pulses can occur until the dead-time has ended and the appropriate full-bridge MOSFETs are turned on. This will guarantee that the mid-points are biased to the output voltage of the buck or COM before an ignition pulse occurs. The full-bridge stops oscillating only when the IC enters Fault Mode or UVLO Mode.

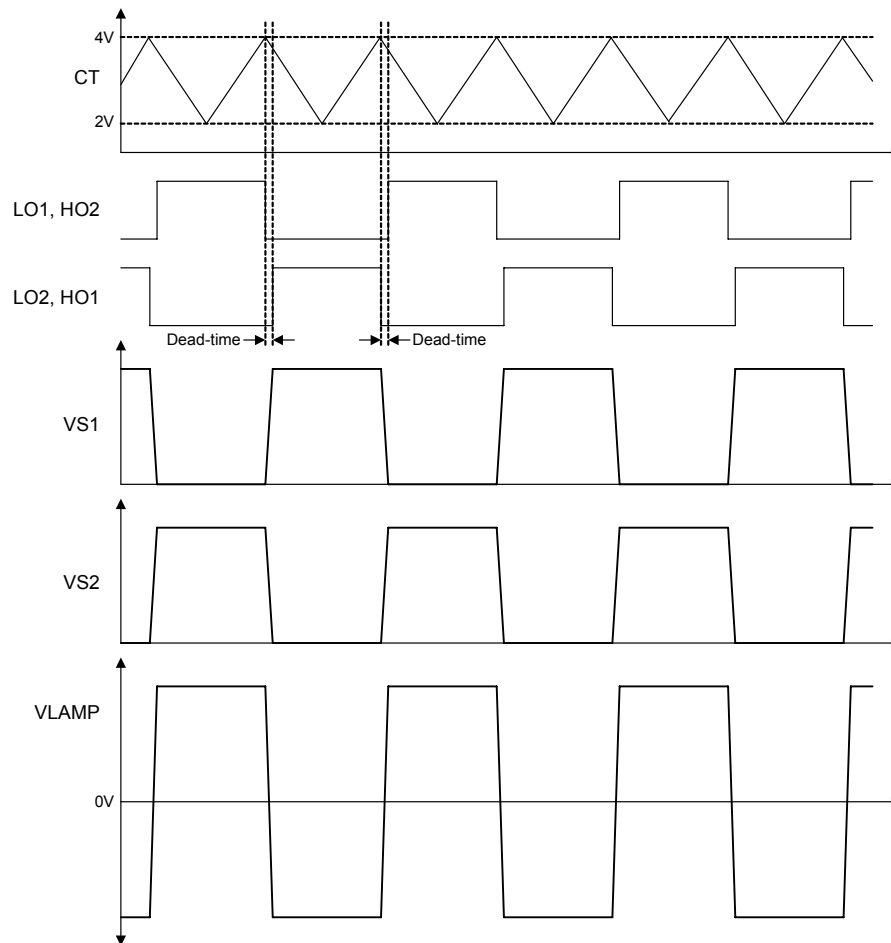

**Figure 6, Full-bridge Timing Diagram**

**Buck Control**

The buck control circuit operates in critical-conduction mode or continuous-conduction mode depending on the off-time of the buck output or the peak current flowing through the buck MOSFET. During normal lamp running conditions, the voltage across the buck current sensing resistor, as measured by the CS pin, is below the internal over-current threshold (1.2V typical). The buck on-time is defined by the time it takes for the internal on-time capacitor to charge up to the voltage level on the PCOMP pin or ICOMP pin, whichever is lower. During the on-

time, the current in the buck inductor charges up to a peak level, depending on the inductance value, and the secondary winding output of the buck inductor is at some negative voltage level, depending on the ratio between the primary and secondary windings. The secondary winding output is measured by the ZX pin, which clamps the negative voltage to a diode drop below COM using the internal ESD diode, and limits the resulting negative current flowing out of the pin with an external resistor, RZX. When the voltage on the internal on-time capacitor exceeds the voltage on the PCOMP pin or ICOMP pin, the on-time has ended and the buck output turns off. The secondary winding output of the buck inductor transitions to some positive voltage level, depending on the ratio between the primary and secondary windings, and causes the ZX pin to exceed the internal 2V threshold. The current in the buck inductor begins to discharge into the lamp full-bridge output stage. When the inductor current reaches zero, the ZX pin decreases back below the 2V threshold. This causes the internal logic of the buck control to start the on-time cycle again. This mode of operation is known as critical-conduction mode because the buck MOSFET is turned on each cycle when the inductor current discharges to zero. The on-time is programmed by the voltage level on the PCOMP pin, and the off-time is determined by the time it takes for the inductor current to discharge to zero, as measured by a negative-going edge on the ZX pin (Figure 7). The resulting shape of the current in the inductor is triangular with a peak value determined by the inductance value and on-time setting.

During lamp warm-up or a short-circuit condition at the output, the inductor current will charge up to an excessive level that can saturate the inductor or damage the buck MOSFET. To prevent this condition, the buck current sensing resistor is set such that the voltage at the CS pin exceeds the internal over-current threshold (1.2V typical) before the inductor saturates. Should the CS pin exceed 1.2V before the internal on-time capacitor reaches the voltage level on the PCOMP pin or ICOMP pin, the on-time will end and the buck output will turn off. The off-time is determined by a negative-going edge on the ZX pin, or, if the maximum off time is reached as programmed by the time it takes for the external capacitor on the TOFF pin to charge up to an internal threshold of 2V. If the maximum off-time is reached before the inductor current discharges to zero, then the inductor will begin charging again from some value above zero. This mode of operation is known as continuous-conduction mode and results in a continuous DC current in the inductor with a ripple bounded above by the over-current threshold and below by the maximum off time setting. Continuous-conduction mode also allows for a higher average current to flow through the buck inductor before saturation occurs than with critical-conduction mode.

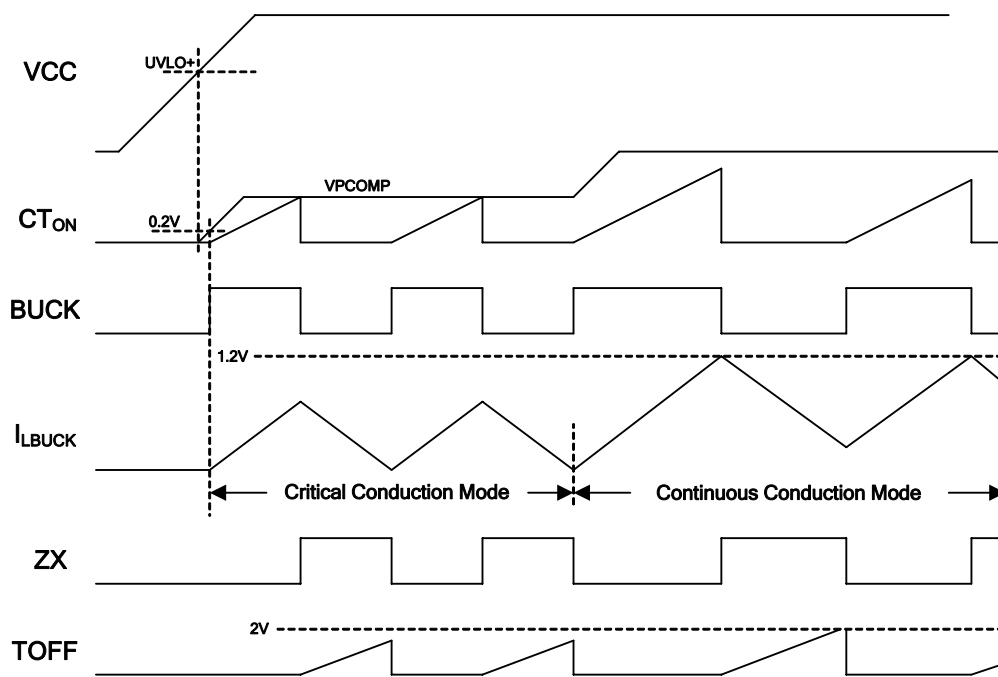

**Figure 7, Buck circuit timing diagram**

### Constant Power Control

During the general mode of operation and after the lamp has ignited, the IC regulates the lamp output power to a constant level. To achieve this, the IC measures the lamp voltage and lamp current at the VSENSE and ISENSE pins, multiplies the voltage and current together using an internal multiplier circuit to calculate power, and regulates the output of the multiplier circuit to a constant reference voltage by increasing or decreasing the buck on-time. If the lamp power is too low then the output of the multiplier will be below the internal reference voltage. The operational trans-conductance amplifier (OTA) will output a sourcing current to the PCOMP pin that will charge up the external capacitor to a higher voltage. This will increase the on-time of buck and increase the output current to the lamp for increasing the output power. If the lamp power is too high, then the opposite will occur. The OTA will output a sinking current to the PCOMP pin that will discharge the external capacitor to a lower voltage. This will decrease the buck on-time and decrease the output current to the lamp for decreasing the output power. The speed of the constant power control loop is set by the value of the external capacitor at the PCOMP pin that determines how fast the loop will react and adjust the buck on-time over the changing load conditions.

### Current Limitation Control

The constant power control loop will increase or decrease the buck current for maintaining constant power in the lamp load. During lamp warm-up, the lamp voltage can be very low (20V typical) and the constant power loop will attempt to increase the buck current to several amps of current to maintain constant power. This high current can exceed the manufacturer's maximum current rating for the HID lamp. To prevent this condition, an additional current limitation control loop has been included in the IC. Should the voltage at the ISENSE pin exceed the voltage level at the OC pin, another OTA will sink current from the ICOMP pin. When the ICOMP pin voltage decreases below the PCOMP pin voltage, then the current limitation loop will override the constant power loop and the ICOMP pin will decrease the buck on-time. The lower of the PCOMP or ICOMP pins will override the other and control the buck on-time. When the lamp eventually warms up and the lamp voltage increases to a level where the lamp current is below the maximum allowable limit (Figure 8), then the ICOMP pin voltage will increase above the PCOMP pin voltage, and the PCOMP pin will control the buck on-time again for maintaining constant power.

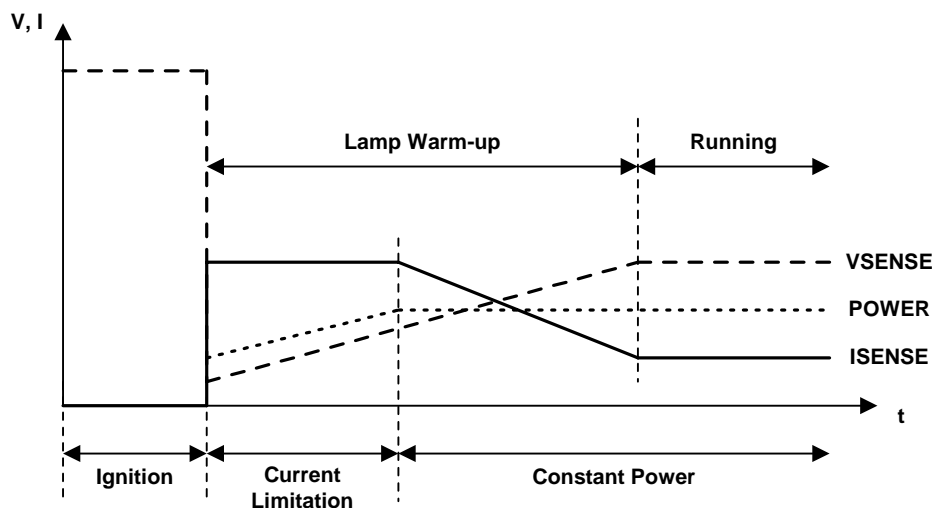

Figure 8, VSENSE and ISENSE pins during ignition, warm-up and running modes.

### Over-Voltage Fault Counter

The IC includes an over-voltage fault counter at the VSENSE pin. The over-voltage fault counter will count the time during which an over-voltage condition at the output of the buck exists due to an open-circuit condition, lamp extinguishes, lamp removal or end-of-life. If the voltage at the VSENSE pin remains above  $VOV(2/5)$  and the over-voltage fault counter times out (787sec typical), then the IC will enter Fault Mode and shutdown. If the voltage at the VSENSE pin decreases below  $VOV(2/5)$  before the over-voltage fault counter times out, then the

lamp has successfully ignited and the IC will enter General Mode. The IGN pin (ignition gate driver output) will remain 'high' until the ignition timer has timed out.

### **Under-Voltage Fault Counter**

The IC also includes an under-voltage fault counter at the VSENSE pin. Once the lamp has ignited, the lamp voltage will decrease sharply to a very low voltage (20V typical). As the lamp warms up, the lamp voltage will slowly increase until the nominal running voltage is reached (100V typical). If the lamp voltage remains too low for too long, then this is a lamp fault condition and the ballast must shutdown. To detect this, the VSENSE pin includes an under-voltage threshold of  $VOV(1/7.5)$ . If the voltage at the VSENSE pin remains below  $VOV(1/7.5)$  and the under-voltage fault counter times out (197sec typical), then the lamp is not warming up properly due to a lamp fault condition (end of life, etc.) and the IC will enter fault mode and shutdown. If the voltage at the VSENSE pin increases above  $VOV(1/7.5)$  before the under-voltage counter times out, then the lamp has successfully warmed up and the IC will remain in general mode. A fast transient under-voltage detection is also included at the VSENSE pin of the IC.

### **Fast Transient Under-Voltage Fault Counter**

During normal running conditions, fast transient under-voltage spikes can occur on the lamp voltage due to instabilities in the lamp arc. The resulting transients on the VSENSE pin will cycle below and above the  $VOV(1/7.5)$  threshold quickly (<50us). If the number of events of these transients exceeds the maximum number of events of the fault counter (16384 events typical), then the IC will enter fault mode and shutdown.

### **Good Counter**

If no faults are detected for a long period of time (2730sec typical), as measured by the good counter, then the fault counter and good counter will both be reset to zero. Also, each time a fault is counted, the good counter is reset to zero.

### **Fault Reset**

To exit Fault Mode and return to UVLO Mode, VCC can be decreased below UVLO- and back above UVLO+, or, the RST pin can be increased above 2.5V.

### **PCB Layout Tips**

Distance between high and low voltage components: It's strongly recommended to place the components tied to the floating voltage pins ( $V_B$  and  $V_S$ ) near the respective high voltage portions of the device.

Ground Plane: In order to minimize noise coupling, the ground plane should not be placed under or near the high voltage floating side.

Gate Drive Loops: Current loops behave like antennas and are able to receive and transmit EM noise (see Figure 9). In order to reduce the EM coupling and improve the power switch turn on/off performance, the gate drive loops must be reduced as much as possible. Moreover, current can be injected inside the gate drive loop via the IGBT collector-to-gate parasitic capacitance. The parasitic auto-inductance of the gate loop contributes to developing a voltage across the gate-emitter, thus increasing the possibility of a self turn-on effect.

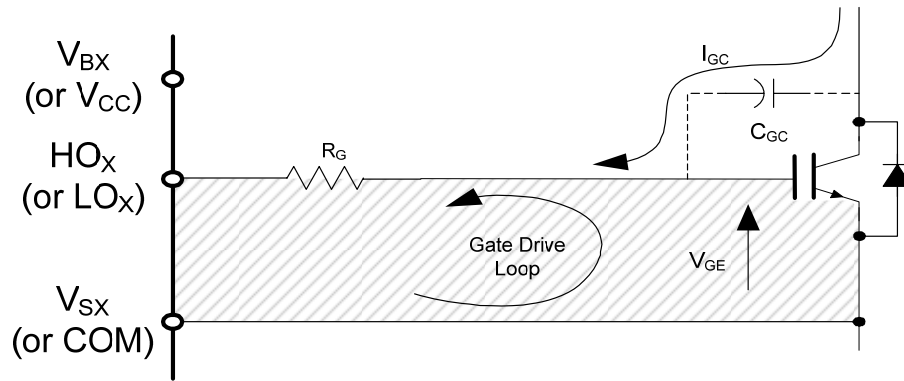

Figure 9: Antenna Loops

**Supply Capacitor:** It is recommended to place a bypass capacitor ( $C_{IN}$ ) between the  $V_{CC}$  and  $V_{SS}$  pins. A ceramic  $1\ \mu\text{F}$  ceramic capacitor is suitable for most applications. This component should be placed as close as possible to the pins in order to reduce parasitic elements.

**Routing and Placement:** Power stage PCB parasitic elements can contribute to large negative voltage transients as the switch node; it is recommended to limit the phase voltage negative transients. In order to avoid such conditions, it is recommended to 1) minimize the high-side emitter to low-side collector distance, and 2) minimize the low-side emitter to negative bus rail stray inductance. However, where negative  $V_S$  spikes remain excessive, further steps may be taken to reduce the spike. This includes placing a resistor ( $5\ \Omega$  or less) between the  $V_S$  pin and the switch node (see Figure 10), and in some cases using a clamping diode between  $V_{SS}$  and  $V_S$  (see Figure 11). See DT04-4 at [www.irf.com](http://www.irf.com) for more detailed information.

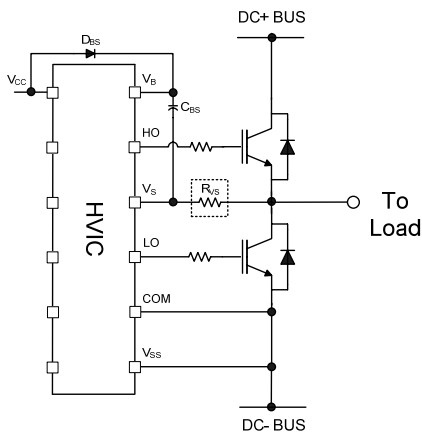

Figure 10:  $V_S$  resistor

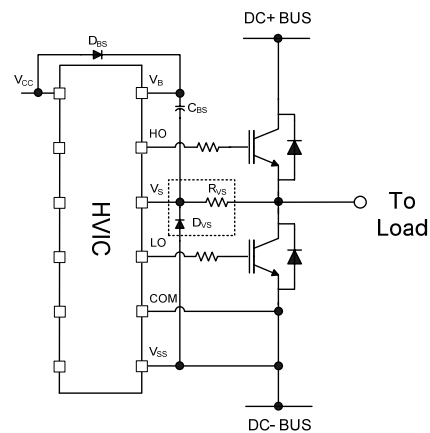

Figure 11:  $V_S$  clamping diode

**Additional Documentation**

Several technical documents related to the use of HVICs are available at [www.irf.com](http://www.irf.com); use the Site Search function and the document number to quickly locate them. Below is a short list of some of these documents.

- DT97-3: Managing Transients in Control IC Driven Power Stages
- AN-1123: Bootstrap Network Analysis: Focusing on the Integrated Bootstrap Functionality
- DT04-4: Using Monolithic High Voltage Gate Drivers
- AN-978: HV Floating MOS-Gate Driver ICs

**Parameter Temperature Trends**

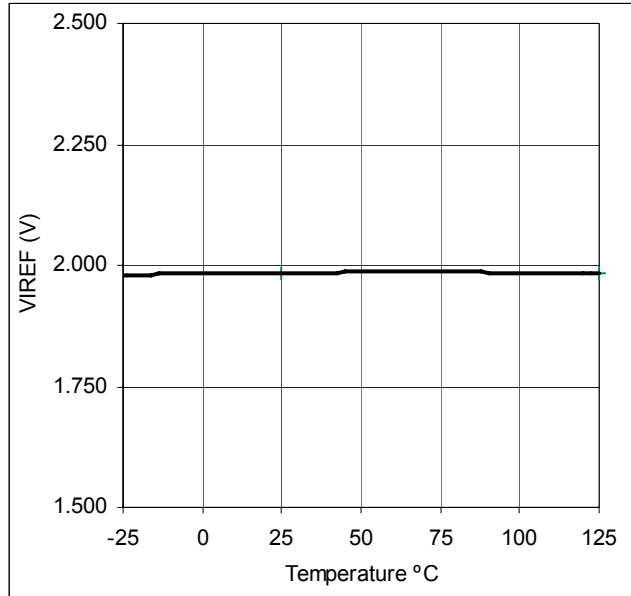

**Fig. 11** VIREF vs. Temperature

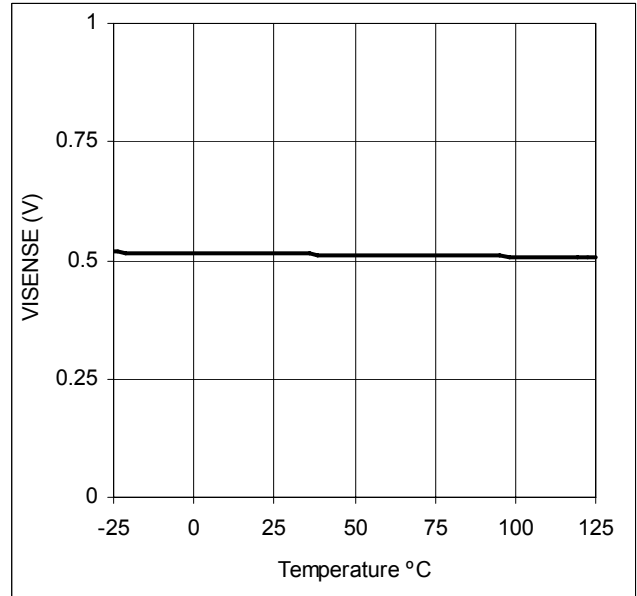

**Fig. 12** VISENSE vs. Temperature

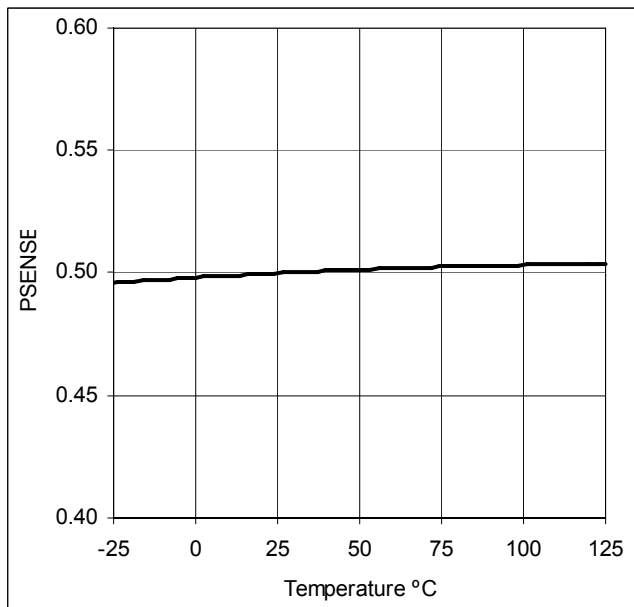

**Fig. 13** PSENSE vs. Temperature

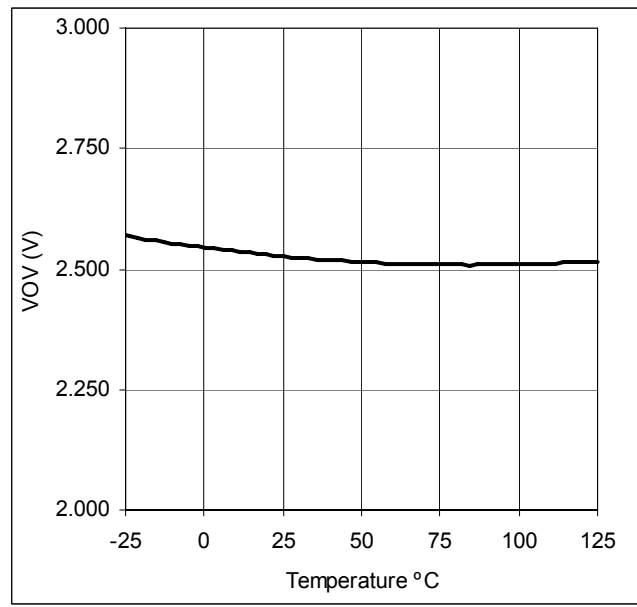

**Fig. 14** VOV vs. Temperature

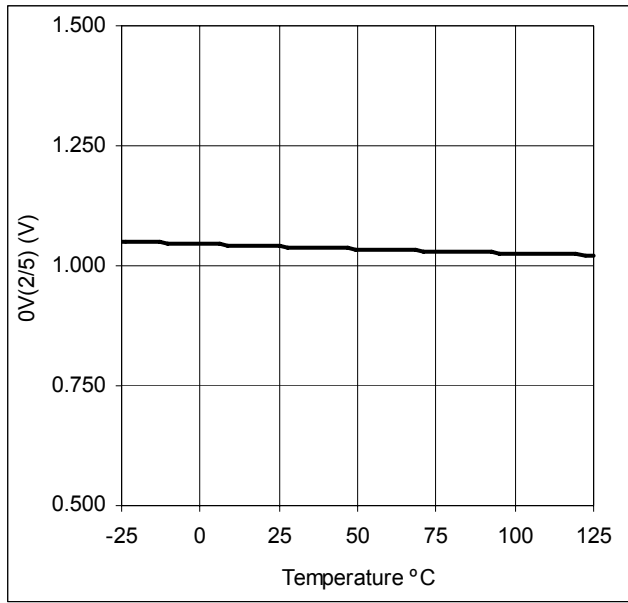

**Fig. 15** OV(2/5) vs. Temperature

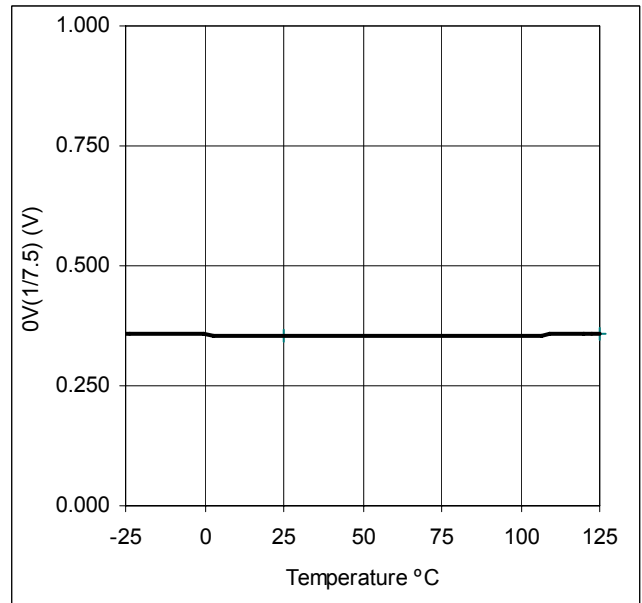

**Fig. 16** OV(1/7.5) vs. Temperature

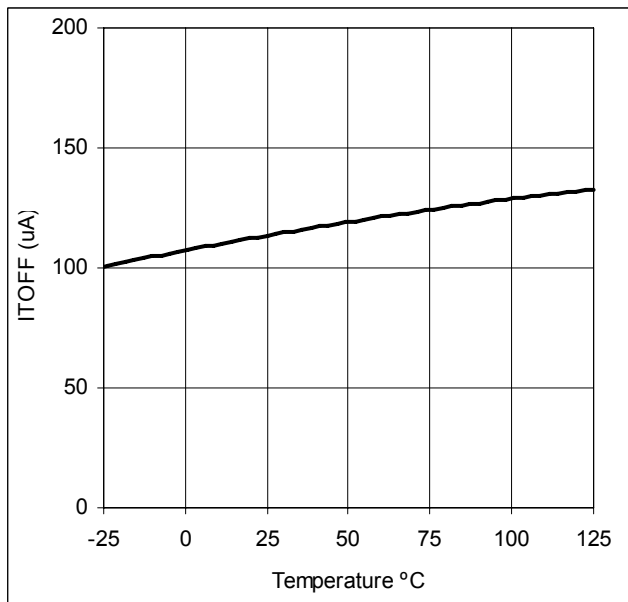

**Fig. 17** ITOFF vs. Temperature

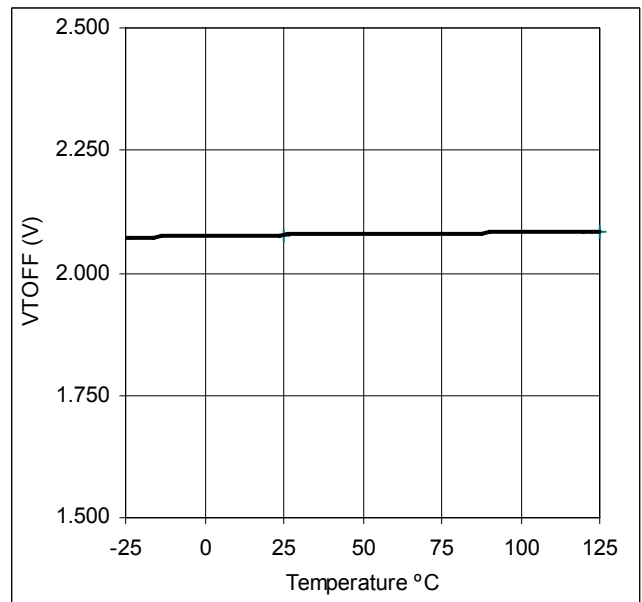

**Fig. 18** VTOFF vs. Temperature



**Package Details: SOIC28W**

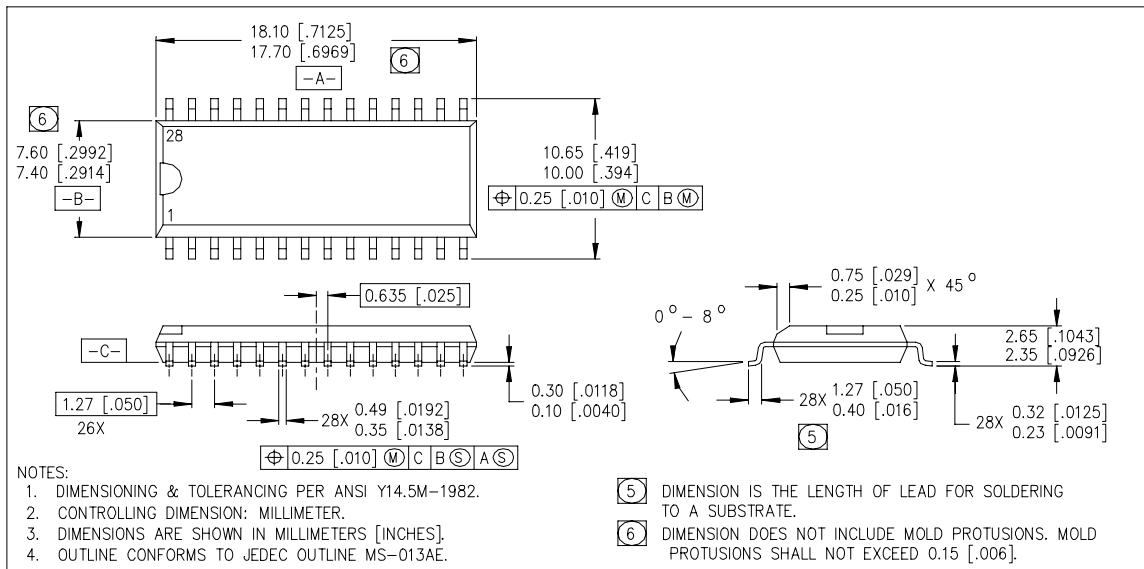

**Package Details: SOIC28W, Tape and Reel**

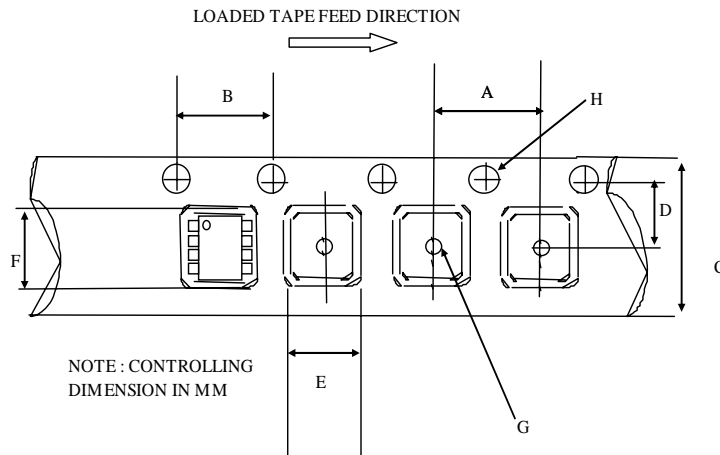

CARRIER TAPE DIMENSION FOR 28SOICW

Code	Metric		Imperial	
	Min	Max	Min	Max
A	11.90	12.10	0.468	0.476
B	3.90	4.10	0.153	0.161
C	23.70	24.30	0.933	0.956
D	11.40	11.60	0.448	0.456
E	10.80	11.00	0.425	0.433
F	18.20	18.40	0.716	0.724
G	1.50	n/a	0.059	n/a
H	1.50	1.60	0.059	0.062

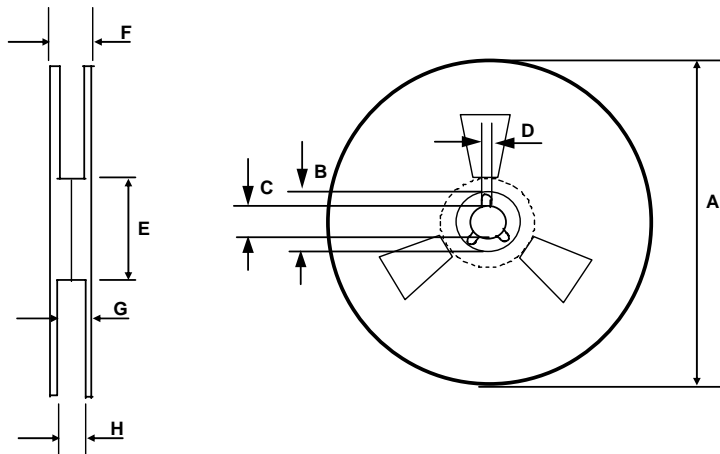

REEL DIMENSIONS FOR 28SOICW

Code	Metric		Imperial	
	Min	Max	Min	Max
A	329.60	330.25	12.976	13.001
B	20.95	21.45	0.824	0.844
C	12.80	13.20	0.503	0.519
D	1.95	2.45	0.767	0.096
E	98.00	102.00	3.858	4.015
F	n/a	30.40	n/a	1.196
G	26.50	29.10	1.04	1.145
H	24.40	26.40	0.96	1.039

**Part Marking Information**

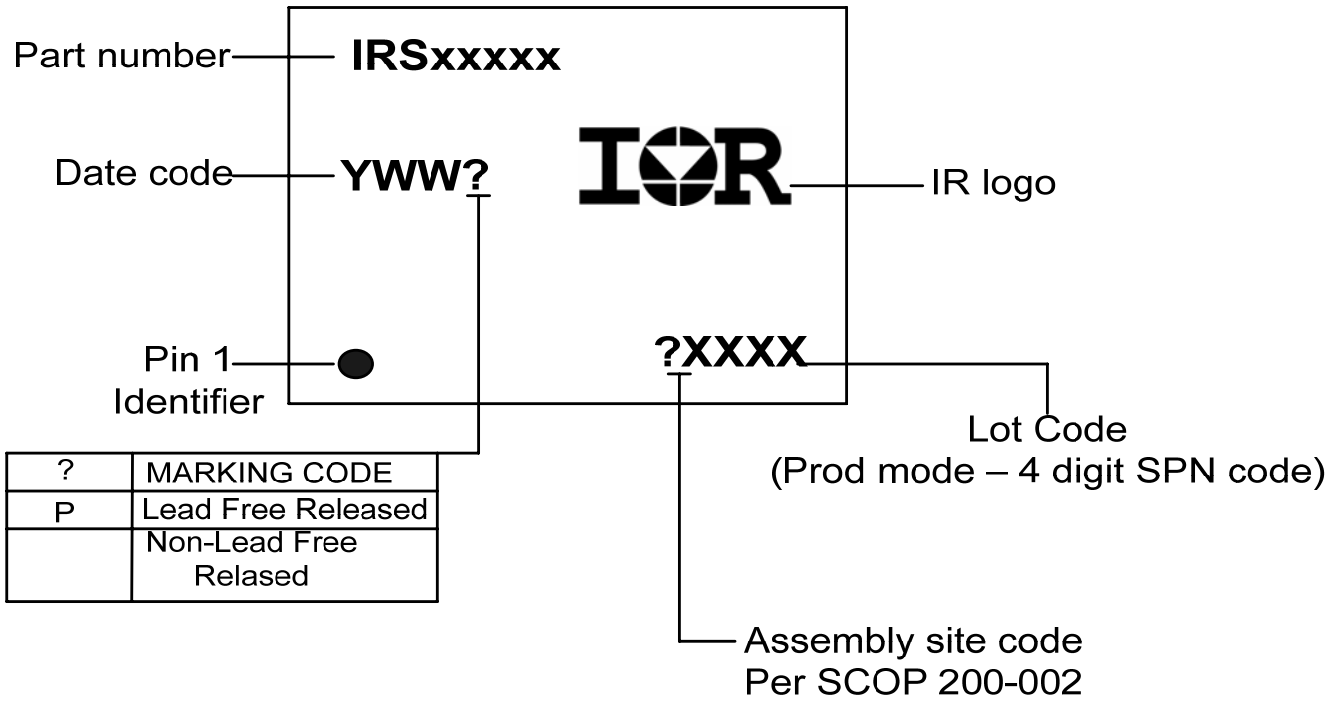

**Ordering Information**

Base Part Number	Package Type	Standard Pack		Complete Part Number
		Form	Quantity	
IRS2573D	SOIC28W	Tube/Bulk	25	IRS2573DSPBF
		Tape and Reel	1000	IRS2573DSTRPBF

The information provided in this document is believed to be accurate and reliable. However, International Rectifier assumes no responsibility for the consequences of the use of this information. International Rectifier assumes no responsibility for any infringement of patents or of other rights of third parties which may result from the use of this information. No license is granted by implication or otherwise under any patent or patent rights of International Rectifier. The specifications mentioned in this document are subject to change without notice. This document supersedes and replaces all information previously supplied.

For technical support, please contact IR's Technical Assistance Center  
<http://www.irf.com/technical-info/>

**WORLD HEADQUARTERS:**  
 233 Kansas St., El Segundo, California 90245  
 Tel: (310) 252-7105