

# Dual-Channel Automotive CCFL Controller

DS3882

## General Description

The DS3882 is a dual-channel cold-cathode fluorescent lamp (CCFL) controller for automotive applications that provides up to 300:1 dimming. It is ideal for driving CCFLs used to backlight liquid crystal displays (LCDs) in navigation and infotainment applications and for driving CCFLs used to backlight instrument clusters. The DS3882 is also appropriate for use in marine and aviation applications.

The DS3882 features EMI suppression functionality and provides a lamp current overdrive mode for rapid lamp heating in cold weather conditions. The DS3882 supports configurations of 1 or 2 lamps with fully independent lamp control and minimal external components. Multiple DS3882 controllers can be cascaded to support applications requiring more than 2 lamps. Control of the DS3882, after initial programming setup, can be completely achieved through I<sup>2</sup>C software communication. Many DS3882 functions are also pin-controllable if software control is not desired.

## Applications

Automotive LCDs  
Instrument Clusters  
Marine and Aviation LCDs

## Pin Configuration

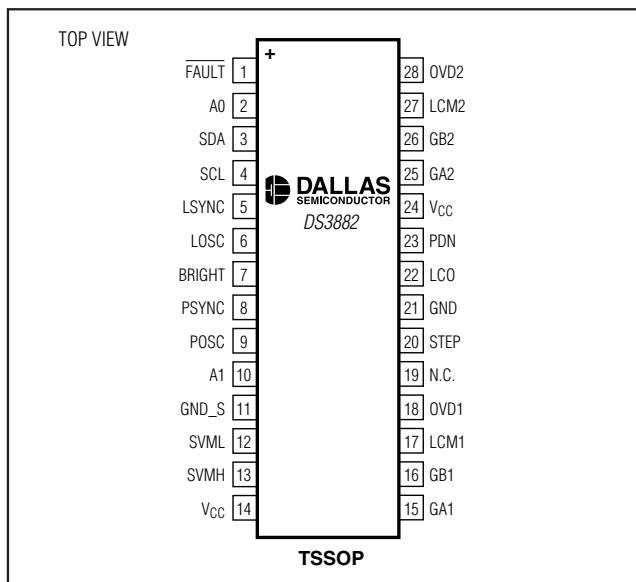

Typical Operating Circuit appears at end of data sheet.

## Features

- ◆ Dual-Channel CCFL Controllers for Backlighting LCD Panels and Instrument Clusters in Automotive Navigation/Infotainment Applications
- ◆ Minimal External Components Required
- ◆ I<sup>2</sup>C Interface
- ◆ Per-Channel Lamp-Fault Monitoring for Lamp-Open, Lamp-Overcurrent, Failure to Strike, and Overvoltage Conditions
- ◆ Status Register Reports Fault Conditions
- ◆ Accurate ( $\pm 5\%$ ) Independent On-Board Oscillators for Lamp Frequency (40kHz to 100kHz) and DPWM Burst-Dimming Frequency (22.5Hz to 440Hz)
- ◆ Lamp and DPWM Frequencies can be Synchronized with External Sources to Reduce Visual LCD Artifacts in Video Applications
- ◆ Optional Spread-Spectrum Lamp Clock Reduces EMI
- ◆ Lamp Frequency can be Stepped Up or Down to Move EMI Spurs Out of Band
- ◆ Lamp Current Overdrive Mode with Automatic Turn-Off Quickly Warms Lamp in Cold Temperatures
- ◆ Analog and Digital Brightness Control
- ◆ 300:1 Dimming Range Possible Using the Digital Brightness Control Option
- ◆ Programmable Soft-Start Minimizes Audible Transformer Noise
- ◆ On-Board Nonvolatile (NV) Memory Allows Device Customization
- ◆ 8-Byte NV User Memory for Storage of Serial Numbers and Date Codes
- ◆ Low-Power Standby Mode
- ◆ 4.75V to 5.25V Single-Supply Operation
- ◆ Temperature Range:  $-40^{\circ}\text{C}$  to  $+105^{\circ}\text{C}$
- ◆ 28-Pin TSSOP Package

## Ordering Information

PART	TEMP RANGE	PIN-PACKAGE
DS3882E+C	$-40^{\circ}\text{C}$ to $+105^{\circ}\text{C}$	28 TSSOP
DS3882E+T&R/C	$-40^{\circ}\text{C}$ to $+105^{\circ}\text{C}$	28 TSSOP

+ Denotes a lead (Pb)-free/RoHS-compliant package.  
T&R = Tape and reel.

# Dual-Channel Automotive CCFL Controller

## ABSOLUTE MAXIMUM RATINGS

Voltage Range on V<sub>CC</sub>, SDA, and  
SCL Relative to Ground .....-0.5V to +6.0V  
Voltage Range on Leads Other than V<sub>CC</sub>, SDA, and  
SCL .....-0.5V to (V<sub>CC</sub> + 0.5V), not to exceed +6.0V  
Continuous Power Dissipation (T<sub>A</sub> = +70°C)  
TSSOP (derate 12.8mW/°C above +70°C) ..... 1025.6mW

Operating Temperature Range .....-40°C to +105°C  
EEPROM Programming Temperature Range .....0°C to +85°C  
Storage Temperature Range .....-55°C to +125°C  
Lead Temperature (soldering, 10s) .....+300°C  
Soldering Temperature (reflow) .....+260°C

Stresses beyond those listed under "Absolute Maximum Ratings" may cause permanent damage to the device. These are stress ratings only, and functional operation of the device at these or any other conditions beyond those indicated in the operational sections of the specifications is not implied. Exposure to absolute maximum rating conditions for extended periods may affect device reliability.

## RECOMMENDED OPERATING CONDITIONS

(T<sub>A</sub> = -40°C to +105°C)

PARAMETER	SYMBOL	CONDITIONS	MIN	TYP	MAX	UNITS
Supply Voltage	V <sub>CC</sub>	(Note 1)	4.75		5.25	V
Input Logic 1	V <sub>IH</sub>		2.0		V <sub>CC</sub> + 0.3	V
Input Logic 0	V <sub>IL</sub>		-0.3		1.0	V
SVML/H Voltage Range	V <sub>SVM</sub>		-0.3		V <sub>CC</sub> + 0.3	V
BRIGHT Voltage Range	V <sub>BRIGHT</sub>		-0.3		V <sub>CC</sub> + 0.3	V
LCM Voltage Range	V <sub>LCM</sub>	(Note 2)	-0.3		V <sub>CC</sub> + 0.3	V
OVD Voltage Range	V <sub>OVD</sub>	(Note 2)	-0.3		V <sub>CC</sub> + 0.3	V
Gate-Driver Output Charge Loading	Q <sub>G</sub>				20	nC

## ELECTRICAL CHARACTERISTICS

(V<sub>CC</sub> = +4.75V to +5.25V, T<sub>A</sub> = -40°C to +105°C.)

PARAMETER	SYMBOL	CONDITIONS	MIN	TYP	MAX	UNITS
Supply Current	I <sub>CC</sub>	G <sub>A</sub> , G <sub>B</sub> loaded with 600pF, 2 channels active		12		mA
Input Leakage (Digital Pins)	I <sub>L</sub>		-1.0		+1.0	μA
Power-Down Current	I <sub>PDN</sub>				2	mA
Output Leakage (SDA, FAULT)	I <sub>LO</sub>	High impedance	-1.0		+1.0	μA
Low-Level Output Voltage (LSYNC, PSYNC)	V <sub>OL</sub>	I <sub>OL</sub> = 4mA			0.4	V
Low-Level Output Voltage (SDA, FAULT)	V <sub>OL1</sub>	I <sub>OL1</sub> = 3mA			0.4	V
	V <sub>OL2</sub>	I <sub>OL2</sub> = 6mA			0.6	
Low-Level Output Voltage (G <sub>A</sub> , G <sub>B</sub> )	V <sub>OL3</sub>	I <sub>OL3</sub> = 4mA			0.4	V
High-Level Output Voltage (LSYNC, PSYNC)	V <sub>OH</sub>	I <sub>OH</sub> = -1mA	2.4			V

# Dual-Channel Automotive CCFL Controller

DS3882

## ELECTRICAL CHARACTERISTICS (continued)

( $V_{CC} = +4.75V$  to  $+5.25V$ ,  $T_A = -40^{\circ}C$  to  $+105^{\circ}C$ .)

PARAMETER	SYMBOL	CONDITIONS	MIN	TYP	MAX	UNITS
High-Level Output Voltage (GA, GB)	$V_{OH1}$	$I_{OH1} = -1mA$	$V_{CC} - 0.4$			V
UVLO Threshold: $V_{CC}$ Rising	$V_{UVLOR}$				4.3	V
UVLO Threshold: $V_{CC}$ Falling	$V_{UVLOF}$		3.7			V
UVLO Hysteresis	$V_{UVLOH}$			200		mV
SVML/H Threshold: Rising	$V_{SVMR}$		2.03	2.08	2.15	V
SVML/H Threshold: Falling	$V_{SVMF}$		1.95	2.02	2.07	V
LCM and OVD DC Bias Voltage	$V_{DCB}$			1.1		V
LCM and OVD Input Resistance	$R_{DCB}$			50		$k\Omega$
Lamp Off Threshold	$V_{LOT}$	(Note 3)	0.22	0.25	0.28	V
Lamp Over Current	$V_{LOC}$	(Note 3)	2.2	2.5	2.8	V
Lamp Regulation Threshold	$V_{LRT}$	(Notes 3, 4)	0.9	1.0	1.1	V
OVD Threshold	$V_{OVDT}$	(Note 3)	0.9	1.0	1.1	V
Lamp Frequency Source Frequency Range	$f_{LFS:OSC}$		40		100	kHz
Lamp Frequency Source Frequency Tolerance	$f_{LFS:TOL}$	LOSC resistor $\pm 2\%$ over temperature	-5		+5	%
Lamp Frequency Receiver Frequency Range	$f_{LFR:OSC}$		40		100	kHz
Lamp Frequency Receiver Duty Cycle	$f_{LFR:DUTY}$		40		60	%
DPWM Source (Resistor) Frequency Range	$f_{DSR:OSC}$		22.5		440.0	Hz
DPWM Source (Resistor) Frequency Tolerance	$f_{DSR:TOL}$	POSC resistor $\pm 2\%$ over temperature	-5		+5	%
DPWM Source (Ext. Clk) Frequency Range	$f_{DSE:OSC}$		22.5		440.0	Hz
DPWM Source (Ext. Clk) Duty Cycle	$f_{DFE:DUTY}$		40		60	%
DPWM Receiver Min Pulse Width	$t_{DR:MIN}$	(Note 5)	25			$\mu s$
BRIGHT Voltage: Minimum Brightness	$V_{BMIN}$				0.5	V
BRIGHT Voltage: Maximum Brightness	$V_{BMAX}$		2.0			V
Gate Driver Output Rise/Fall Time	$t_R / t_F$	$C_L = 600pF$			100	ns
GAn and GBn Duty Cycle		(Note 6)			44	%

# Dual-Channel Automotive CCFL Controller

## I<sup>2</sup>C AC ELECTRICAL CHARACTERISTICS (See Figure 9)

(V<sub>CC</sub> = +4.75V to +5.25V, T<sub>A</sub> = -40°C to +105°C, timing referenced to V<sub>IL(MAX)</sub> and V<sub>IH(MIN)</sub>.)

PARAMETER	SYMBOL	CONDITIONS	MIN	TYP	MAX	UNITS
SCL Clock Frequency	f <sub>SCL</sub>	(Note 7)	0		400	kHz
Bus Free Time Between Stop and Start Conditions	t <sub>BUF</sub>		1.3			μs
Hold Time (Repeated) Start Condition	t <sub>HD:STA</sub>	(Note 8)	0.6			μs
Low Period of SCL	t <sub>LOW</sub>		1.3			μs
High Period of SCL	t <sub>HIGH</sub>		0.6			μs
Data Hold Time	t <sub>HD:DAT</sub>		0		0.9	μs
Data Setup Time	t <sub>SU:DAT</sub>		100			ns
Start Setup Time	t <sub>SU:STA</sub>		0.6			μs
SDA and SCL Rise Time	t <sub>R</sub>	(Note 9)	20+ 0.1C <sub>B</sub>		300	ns
SDA and SCL Fall Time	t <sub>F</sub>	(Note 9)	20+ 0.1C <sub>B</sub>		300	ns
Stop Setup Time	t <sub>SU:STO</sub>		0.6			μs
SDA and SCL Capacitive Loading	C <sub>B</sub>	(Note 9)			400	pF
EEPROM Write Time	t <sub>W</sub>	(Note 10)		20	30	ms

## NONVOLATILE MEMORY CHARACTERISTICS

(V<sub>CC</sub> = +4.75V to 5.25V)

PARAMETER	SYMBOL	CONDITIONS	MIN	TYP	MAX	UNITS
EEPROM Write Cycles		+85°C (Note 11)	30,000			

**Note 1:** All voltages are referenced to ground unless otherwise noted. Currents into the IC are positive, out of the IC negative.

**Note 2:** During fault conditions, the AC-coupled feedback values are allowed to be below the absolute max rating of the LCM or OVD pin for up to 1 second.

**Note 3:** Voltage with respect to V<sub>DCB</sub>.

**Note 4:** Lamp overdrive and analog dimming (based on reduction of lamp current) are disabled.

**Note 5:** This is the minimum pulse width guaranteed to generate an output burst, which generates the DS3882's minimum burst duty cycle. This duty cycle may be greater than the duty cycle of the PSYNC input. Once the duty cycle of the PSYNC input is greater than the DS3882's minimum duty cycle, the output's duty cycle tracks the PSYNC's duty cycle. Leaving PSYNC low (0% duty cycle) disables the GAn and GBn outputs in DPWM receiver mode.

**Note 6:** This is the maximum lamp frequency duty cycle that is generated at any of the GAn or GBn outputs with spread-spectrum modulation disabled.

**Note 7:** I<sup>2</sup>C interface timing shown is for fast-mode (400kHz) operation. This device is also backward compatible with I<sup>2</sup>C standard-mode timing.

**Note 8:** After this period, the first clock pulse can be generated.

**Note 9:** C<sub>B</sub>—total capacitance allowed on one bus line in picofarads.

**Note 10:** EEPROM write time applies to all the EEPROM memory. EEPROM write begins after a stop condition occurs.

**Note 11:** Guaranteed by design.

# Dual-Channel Automotive CCFL Controller

## Typical Operating Characteristics

DS3882

( $V_{CC} = 5.0V$ ,  $T_A = +25^\circ C$ , unless otherwise noted.)

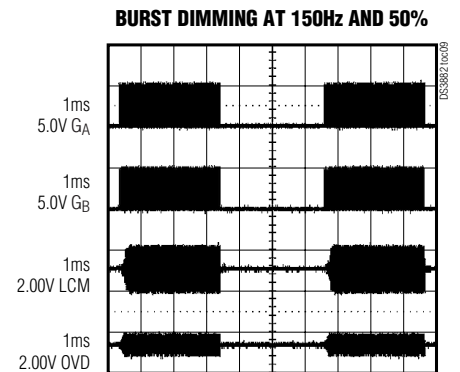
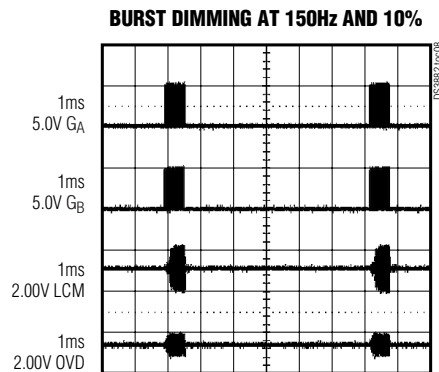
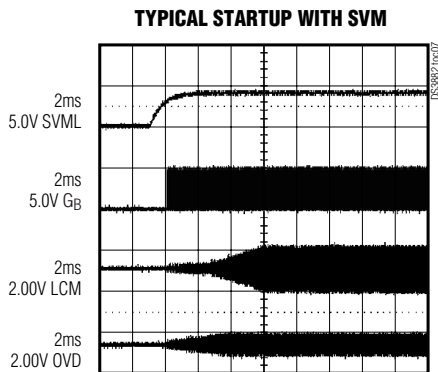
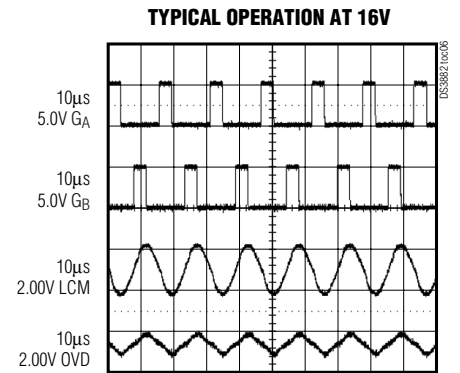
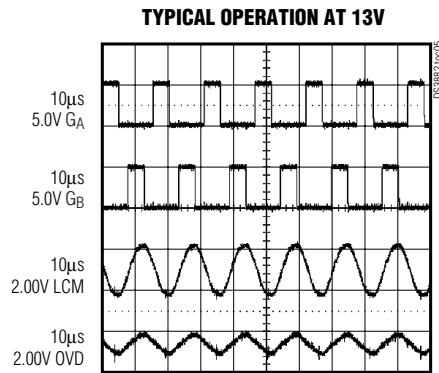
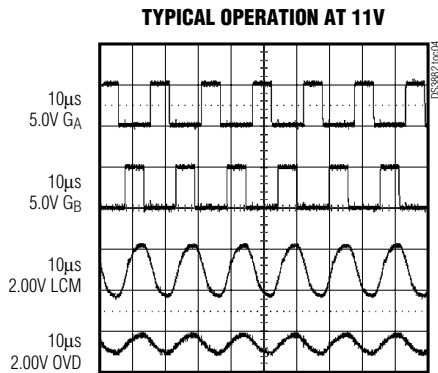
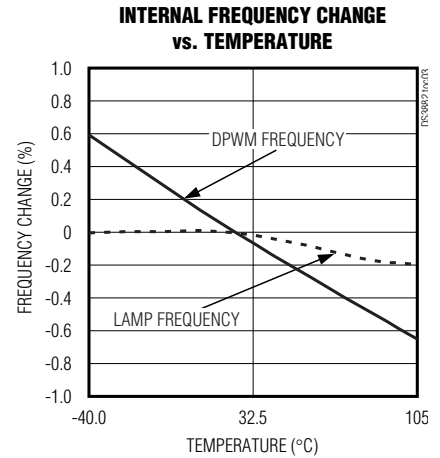
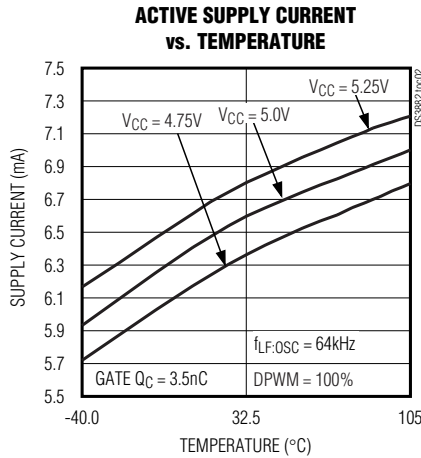
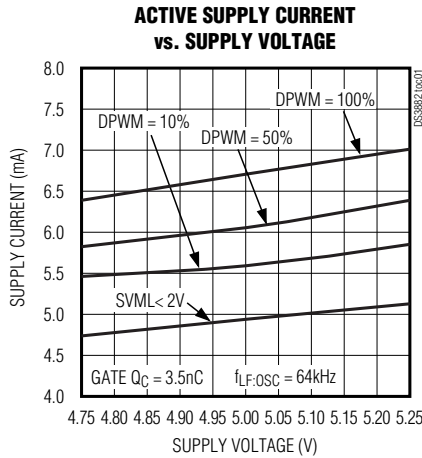

# Dual-Channel Automotive CCFL Controller

## Typical Operating Characteristics (continued)

( $V_{CC} = 5.0V$ ,  $T_A = +25^\circ C$ , unless otherwise noted.)

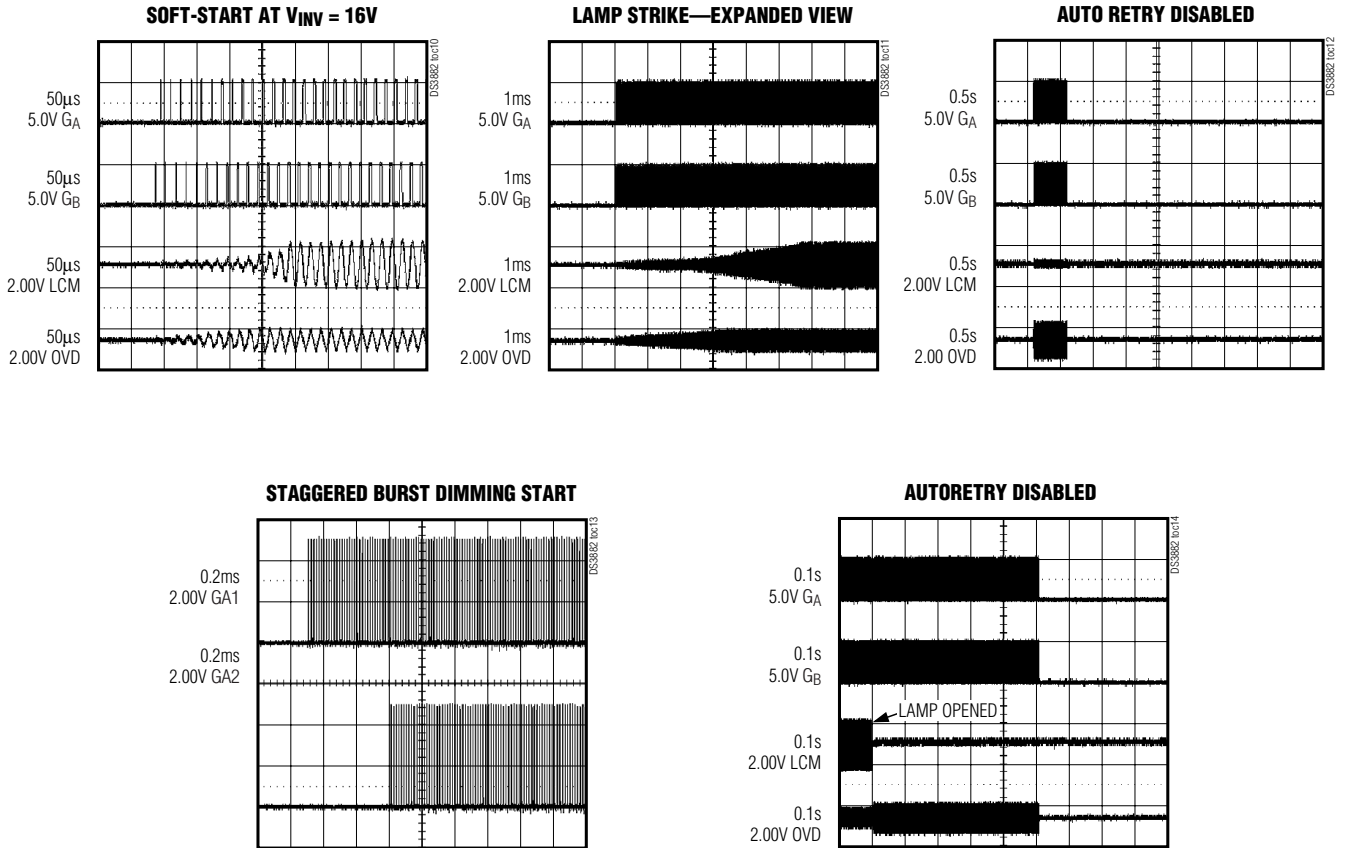

# Dual-Channel Automotive CCFL Controller

## Pin Description

**DS3882**

NAME	PINS BY CHANNEL (n)		FUNCTION
	CH 1	CH 2	
GA <sub>n</sub>	15	25	MOSFET A Gate Drive. Connect directly to logic-level mode n-channel MOSFET. Leave open if channel is unused.
GB <sub>n</sub>	16	26	MOSFET B Gate Drive. Connect directly to logic-level mode n-channel MOSFET. Leave open if channel is unused.
LCM <sub>n</sub>	17	27	Lamp Current Monitor Input. Lamp current is monitored by a resistor placed in series with the low-voltage side of the lamp. Leave open if channel is unused.
OVD <sub>n</sub>	18	28	Overvoltage Detection. Lamp voltage is monitored by a capacitor divider placed on the high-voltage side of the transformer. Leave open if channel is unused.
<b>NAME</b>			
<b>PIN</b>		<b>FUNCTION</b>	
FAULT	1	Active-Low Fault Output. This open-drain pin requires external pullup resistor to realize high logic levels.	
A0	2	Address Select Input. Determines I <sup>2</sup> C slave address.	
SDA	3	Serial-Data Input/Output. I <sup>2</sup> C bidirectional data pin, which requires a pullup resistor to realize high logic levels.	
SCL	4	Serial Clock Input. I <sup>2</sup> C clock input.	
LSYNC	5	Lamp Frequency Input/Output. This pin is the input for an externally sourced lamp frequency when the DS3882 is configured as a lamp frequency receiver. If the DS3882 is configured as a lamp frequency source (i.e., the lamp frequency is generated internally), the frequency is output on this pin for use by other lamp frequency receiver DS3882s.	
LOSC	6	Lamp Oscillator Resistor Adjust. A resistor to ground on this pin sets the frequency of the internal lamp oscillator.	
BRIGHT	7	Analog Brightness Control Input. Used to control the DPWM dimming feature. Ground if unused.	
PSYNC	8	DPWM Input/Output. This pin is the input for an externally generated DPWM signal when the DS3882 is configured as a DPWM receiver. If the DS3882 is configured as a DPWM source (i.e., the DPWM signal is generated internally), the DPWM signal is output on this pin for use by other DPWM receiver DS3882s.	

# Dual-Channel Automotive CCFL Controller

## Pin Description (continued)

NAME	PIN	FUNCTION
POSC	9	DPWM Oscillator Resistor Adjust. A resistor to ground on this lead sets the frequency of the DPWM oscillator. This lead can optionally accept a 22.5Hz to 440Hz clock that will become the source timing of the internal DPWM signal.
A1	10	Address Select Input. Determines I <sup>2</sup> C slave address.
GND_S	11	I <sup>2</sup> C Interface Ground Connection. GND_S must be at the same potential as GND.
SVML	12	Low-Supply Voltage Monitor Input. Used to monitor the inverter voltage for undervoltage conditions.
SVMH	13	High-Supply Voltage Monitor Input. Used to monitor the inverter voltage for overvoltage conditions.
V <sub>CC</sub>	14, 24	Power-Supply Connections. Both pins must be connected.
N.C.	19	No Connection. Do not connect any signal to this pin.
STEP	20	Lamp Frequency Step Input. This active-high digital input moves the lamp oscillator frequency up or down by 1%, 2%, 3%, or 4% as configured in the EMIC register. This pin is logically ORed with the STEPE bit in the EMIC register.
GND	21	Ground Connection
LCO	22	Lamp Current Overdrive Enable Input. A high digital level at this input enables the lamp current overdrive circuit. The amount of overdrive current is configured by the LCOC register. When this input is low, the lamp current is set to its nominal level. This pin is logically ORed with the LCOE bit in the LCOC register.
PDN	23	Lamp On/Off Control Input. A low digital level at this input turns the lamp on. A high digital level turns the lamps off, clears the fault logic, and places the device into the power-down mode. The high-to-low transition on this input issues a controller reset, which clears the fault logic and reinitiates a lamp strike. This pin is logically ORed with the PDNE bit in the CR2 register.



# Dual-Channel Automotive CCFL Controller

## Functional Diagrams

**DS3882**

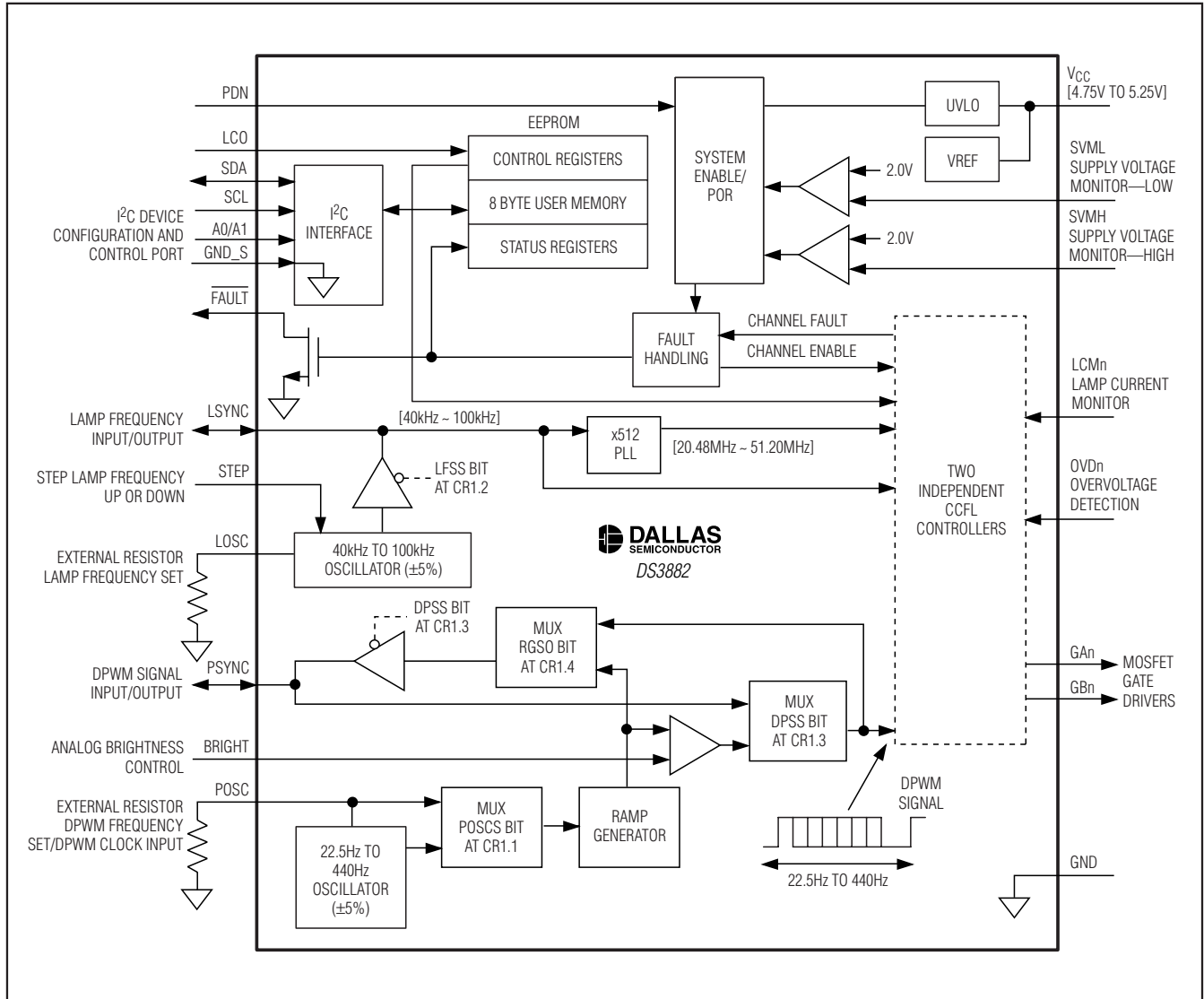

Figure 1. Functional Diagram

# Dual-Channel Automotive CCFL Controller

## Functional Diagrams (continued)

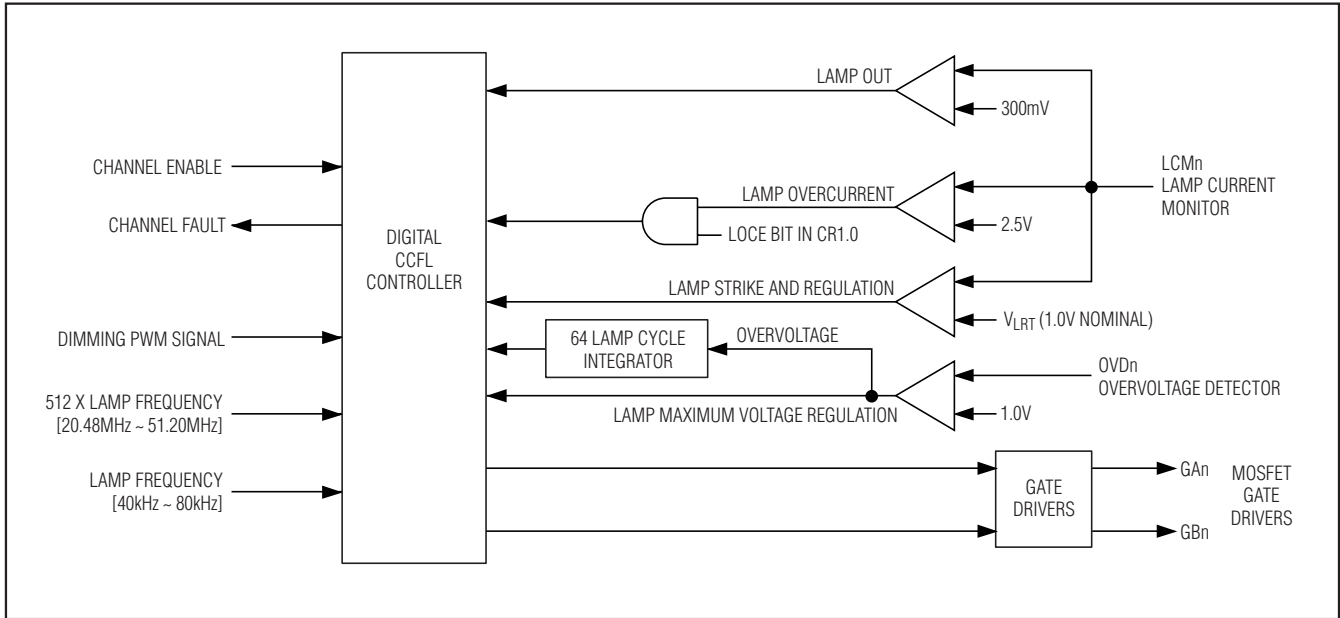

Figure 2. Per Channel Logic Diagram

## Detailed Description

The DS3882 uses a push-pull drive scheme to convert a DC voltage (8V to 16V) to the high-voltage (300V<sub>RMS</sub> to 1000V<sub>RMS</sub>) AC waveform that is required to power the CCFLs. The push-pull drive scheme uses a minimal number of external components, which reduces assembly cost and makes the printed circuit board design easy to implement. The push-pull drive scheme also provides an efficient DC-to-AC conversion and produces near-sinusoidal waveforms.

Each DS3882 channel drives two logic-level n-channel MOSFETs that are connected between the ends of a step-up transformer and ground (see the *Typical Operating Circuit*). The transformer has a center tap on the primary side that is connected to a DC voltage supply. The DS3882 alternately turns on the two MOSFETs to create the high-voltage AC waveform on the secondary side. By varying the duration of the MOSFET turn-on times, the CCFL current is able to be accurately controlled.

A resistor in series with the CCFL's ground connection enables current monitoring. The voltage across this resistor is fed to the lamp current monitor (LCM) input and compared to an internal reference voltage to deter-

mine the duty cycle for the MOSFET gates. Each CCFL receives independent current monitoring and control, which maximizes the lamp's brightness and lifetime.

Block diagrams of the DS3882 are shown in Figures 1 and 2. More operating details of the DS3882 are discussed on the following pages of this data sheet.

## Memory Registers and I<sup>2</sup>C-Compatible Serial Interface

The DS3882 uses an I<sup>2</sup>C-compatible serial interface for communication with the on-board EEPROM and SRAM configuration/status registers as well as user memory. The configuration registers, which are a mixture of shadowed EEPROM and SRAM, allow the user to customize many DS3882 parameters such as the soft-start ramp rate, the lamp and dimming frequency sources, brightness of the lamps, fault-monitoring options, channel enabling/disabling, EMI control, and lamp current overdrive control. The eight bytes of NV user memory can be used to store manufacturing data such as date codes, serial numbers, or product identification numbers. The device is shipped from the factory with the configuration registers programmed to a set of default configuration parameters. To inquire about custom programming, contact the factory.

# Dual-Channel Automotive CCFL Controller

## Shadowed EEPROM

The DS3882 incorporates SRAM-shadowed EEPROM memory locations for all memory that needs to be retained during power cycling. At power-up, SEEB (bit 7 of the BLC register) is low which causes the shadowed locations to act as ordinary EEPROM. Setting SEEB high disables the EEPROM write function and causes the shadowed locations to function as ordinary SRAM cells. This allows an infinite number of write cycles without causing EEPROM damage and also eliminates the EEPROM write time,  $t_{W}$  from the write cycle. Because memory changes made when SEEB is set high are not written to EEPROM, these changes are not retained through power cycles, and the power-up EEPROM values are the last values written with SEEB low.

## Channel Phasing

The lamp-frequency MOSFET gate turn-on times are out of phase between the two channels during the burst period. This reduces the inrush current that would result from all lamps switching simultaneously, and hence eases the design requirements for the DC supply. It is important to note that it is the lamp-frequency signals that are phased, not the DPWM (burst) signals.

## Lamp Dimming Control

The DS3882 provides two independent methods of lamp dimming that can be combined to achieve a dimming ratio of 300:1 or greater. The first method is “burst” dimming, which uses a digital pulse-width-modulated (DPWM) signal (22.5Hz to 440Hz) to control the lamp brightness. The second is “analog” dimming, which is accomplished by adjusting the lamp current. Burst dimming provides 128 linearly spaced brightness steps. Analog dimming provides smaller substeps that allow incremental brightness changes between burst dimming steps. This ability is especially useful for low-brightness dimming changes, where using burst dimming alone would cause visible brightness step changes. Analog dimming also allows the brightness to be reduced below the minimum burst dimming level, which provides for the maximum dimming range.

Burst dimming can be controlled using a user-supplied analog voltage on the BRIGHT pin or through the I<sup>2</sup>C interface. Analog dimming can only be controlled through the I<sup>2</sup>C interface. Therefore, for applications that require the complete dimming range and resolution capability of the DS3882, I<sup>2</sup>C dimming control must be used.

## Burst Dimming

Burst dimming increases/decreases the brightness by adjusting (i.e., modulating) the duty cycle of the DPWM signal. During the high period of the DPWM cycle, the lamps are driven at the selected lamp frequency

(40kHz to 100kHz) as shown in Figure 6. This part of the cycle is called the “burst” period because of the lamp frequency burst that occurs during this time. During the low period of the DPWM cycle, the controller disables the MOSFET gate drivers so the lamps are not driven. This causes the current to stop flowing in the lamps, but the time is short enough to keep the lamps from de-ionizing.

The DS3882 can generate its own DPWM signal internally (set DPSS = 0 in CR1), which can then be sourced to other DS3882s if required, or the DPWM signal can be supplied from an external source (set DPSS = 1 in CR1). To generate the DPWM signal internally, the DS3882 requires a clock (referred to as the dimming clock) to set the DPWM frequency. The user can supply the dimming clock by setting POSCS = 1 in CR1 and applying an external 22.5Hz to 440Hz signal at the POSC pin, or the dimming clock can be generated by the DS3882’s internal oscillator (set POSCS = 0 in CR1), in which case the frequency is set by an external resistor at the POSC pin. These two dimming clock options are shown in Figure 3. Regardless of whether the dimming clock is generated internally or sourced externally, the POSCR0 and POSCR1 bits in CR2 must be set to match the desired dimming clock frequency.

The internally generated DPWM signal can be provided at the PSYNC I/O pin (set RGSO = 0 in CR1) for sourcing to other DS3882s, if any, in the circuit. This allows all DS3882s in the system to be synchronized to the same DPWM signal. A DS3882 that is generating the DPWM signal for other DS3882s in the system is referred to as the DPWM source. When bringing in an externally generated DPWM signal, either from another DS3882 acting as a DPWM source or from some other user-provided source, it is input into the PSYNC I/O pin of the DS3882, and the receiving DS3882 is referred to a DPWM receiver. In this mode, the BRIGHT and POSC inputs are disabled and should be grounded (see Figure 5).

When the DPWM signal is generated internally, its duty cycle (and, thus, the lamp brightness) is controlled either by a user-supplied analog voltage at the BRIGHT input or through the I<sup>2</sup>C interface by varying the 7-bit PWM code in the BPWM register. When using the BRIGHT pin to control burst dimming, a voltage of less than 0.5V causes the DS3882 to operate with the minimum burst duty cycle, providing the lowest brightness setting, while any voltage greater than 2.0V causes a 100% burst duty cycle (i.e., lamps always being driven), which provides the maximum brightness. For voltages between 0.5V and 2V, the duty cycle varies linearly between the minimum and 100%. Writing a

# Dual-Channel Automotive CCFL Controller

non-zero PWM code to the BPWM register disables the BRIGHT pin and enables I<sup>2</sup>C burst dimming control. Setting the 7-bit PWM code to 0000001b causes the DS3882 to operate with the minimum burst duty cycle, while a setting of 1111111b causes a 100% burst duty cycle. For settings between these two codes, the duty cycle varies linearly between the minimum and 100%.

## Analog Dimming

Analog dimming changes the brightness by increasing or decreasing the lamp current. The DS3882 accomplishes this by making small shifts to the lamp regulation voltage, V<sub>LRT</sub> (see Figure 2). Analog dimming is only possible by software communication with the lower five bits (LC4–LC0) in the BLC register. This function is not pin controllable. The default power-on state of the LC bits is 00000b, which corresponds to 100% of the nominal current level. Therefore on power-up, analog dimming does not interfere with burst dimming functionality if it is not desired. Setting the LC bits to 11111b reduces the lamp current to 35% of its nominal level. For LC values between 11111b and 00000b, the lamp current varies linearly between 35% and 100% of nominal.

## Lamp Frequency Configuration

The DS3882 can generate its own lamp frequency clock internally (set LFSS = 0 in CR1), which can then be sourced to other DS3882s if required, or the lamp clock can be supplied from an external source (set LFSS = 1 in CR1). When the lamp clock is internally generated, the frequency (40kHz to 100kHz) is set by

an external resistor at the LOSC. In this case, the DS3882 can act as a lamp frequency source because the lamp clock is output at the LSYNC I/O pin for synchronizing any other DS3882s configured as lamp frequency receivers. While DS3882 is sourcing lamp frequency to other DS3882's and spread-spectrum modulation or frequency step features are enabled, the LSYNC output is not affected by either EMI suppression features. The DS3882 acts as a lamp frequency receiver when the lamp clock is supplied externally. In this case, a 40kHz to 100kHz clock must be supplied at the LSYNC I/O. The external clock can originate from the LSYNC I/O of a DS3882 configured as a lamp frequency source or from some other source.

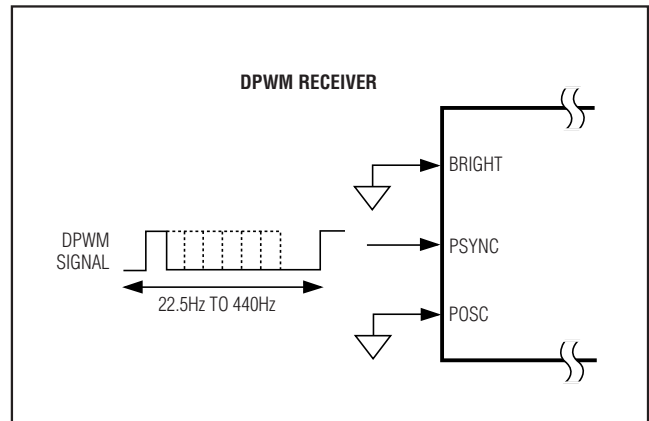

Figure 4. DPWM Receiver Configuration

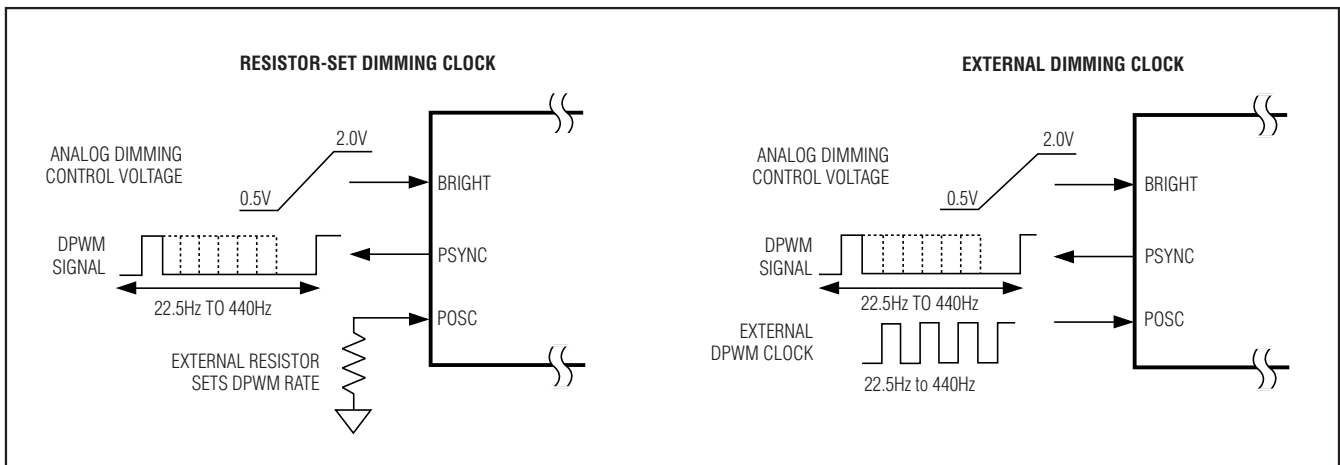

Figure 3. DPWM Source Configuration Options

# Dual-Channel Automotive CCFL Controller

DS3882

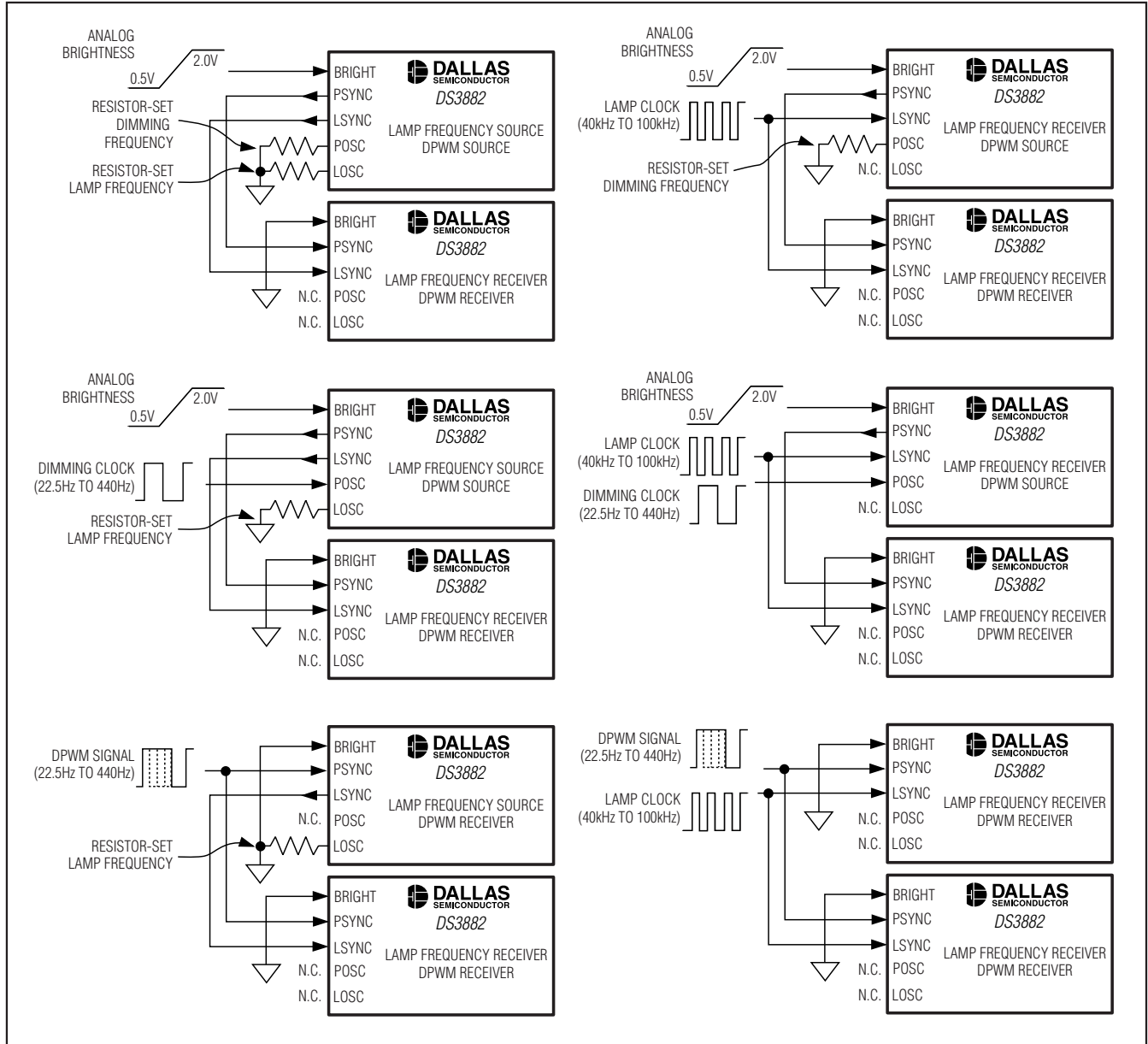

Figure 5. Frequency Configuration Options for Designs Using Multiple DS3882s

# Dual-Channel Automotive CCFL Controller

## Configuring Systems with Multiple DS3882s

The source and receiver options for the lamp frequency clock and DPWM signal allow multiple DS3882s to be synchronized in systems requiring more than two lamps. The lamp and dimming clocks can either be generated on board the DS3882 using external resistors to set the frequency, or they can be sourced by the host system to synchronize the DS3882 to other system resources. Figure 5 shows various multiple DS3882 configurations that allow both lamp and/or DPWM synchronization for all DS3882s in the system.

## DPWM Soft-Start

At the beginning of each lamp burst, the DS3882 provides a soft-start that slowly increases the MOSFET

gate-driver duty cycle (see Figure 6). This minimizes the possibility of audible transformer noise that could result from current surges in the transformer primary. The soft-start length is fixed at 16 lamp cycles, but the soft-start ramp profile is programmable through the four soft-start profile registers (SSP1/2/3/4) and can be adjusted to match the application. There are seven different driver duty cycles to select from to customize the soft-start ramp (see Tables 5a and 5b). The available duty cycles range from 0% to 19% in ~3% increments. In addition, the MOSFET duty cycle from the last lamp cycle of the previous burst can be used as part of the soft-start ramp by using the most recent value duty cycle code. Each programmed MOSFET gate duty cycle repeats twice to make up the 16 soft-start lamp cycles.

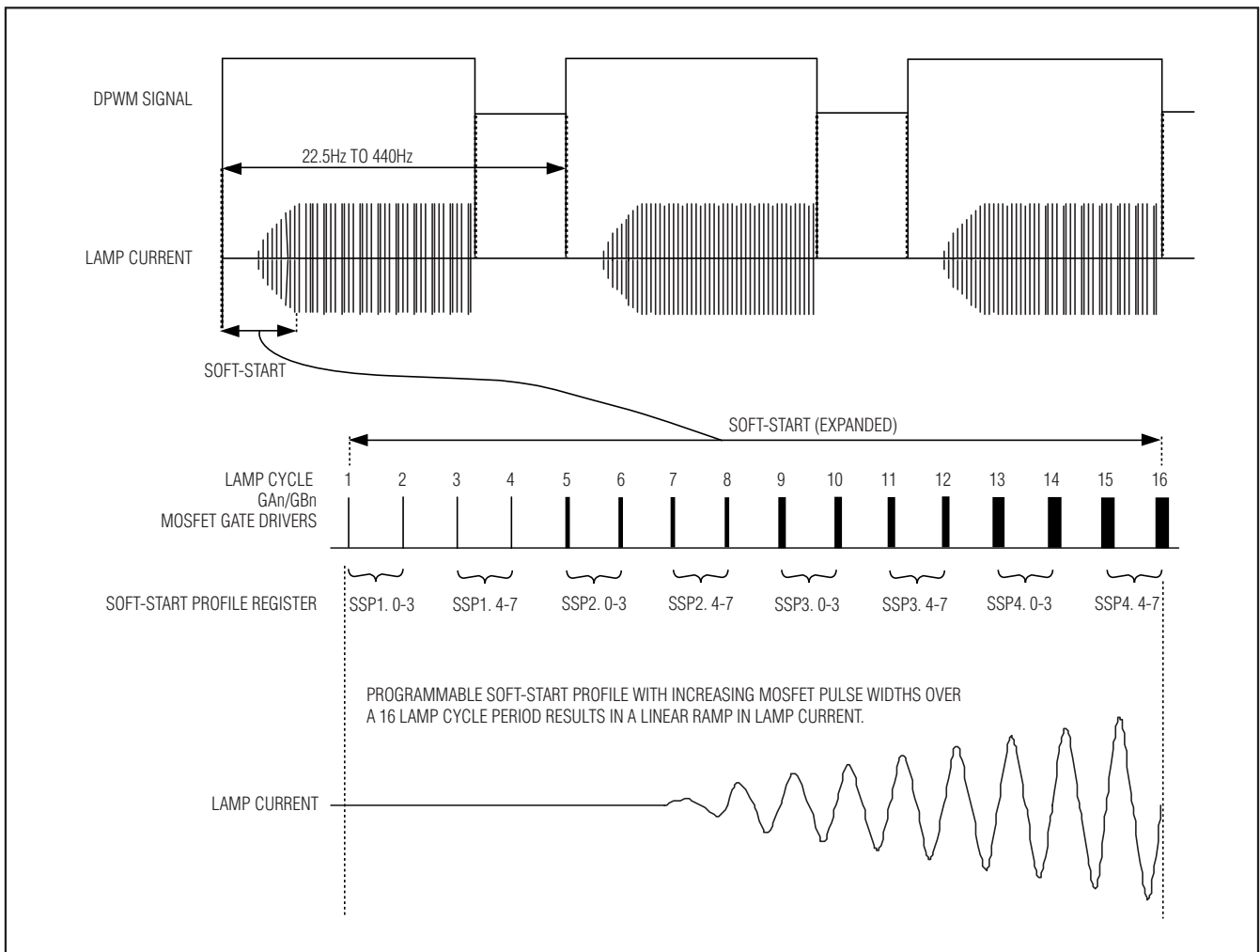

Figure 6. Digital PWM Dimming and Soft-Start

# Dual-Channel Automotive CCFL Controller

## Setting the Lamp and Dimming Clock (DPWM) Frequencies Using External Resistors

Both the lamp and dimming clock frequencies can be set using external resistors. The resistance required for either frequency can be determined using the following formula:

$$R_{OSC} = \frac{K}{f_{OSC}}$$

where  $K = 1600k\Omega \cdot kHz$  for lamp frequency calculations. When calculating the resistor value for the dimming clock frequency,  $K$  will be one of four values as determined by the desired frequency and the POSCR0 and POSCR1 bit settings as shown in the Control Register 2 (CR2) Table 7 in the *Detailed Register Descriptions* section.

Example: Selecting the resistor values to configure a DS3882 to have a 50kHz lamp frequency and a 160Hz dimming clock frequency: For this configuration, POSCR0 and POSCR1 must be programmed to 1 and 0, respectively, to select 90Hz to 220Hz as the dimming clock frequency range. This sets  $K$  for the dimming clock resistor ( $R_{POSC}$ ) calculation to  $4k\Omega \cdot kHz$ . For the lamp frequency resistor ( $R_{LOSC}$ ) calculation,  $K = 1600k\Omega \cdot kHz$ , which sets the lamp frequency  $K$  value regardless of the frequency. The formula above can now be used to calculate the resistor values for  $R_{LOSC}$  and  $R_{POSC}$  as follows:

$$R_{LOSC} = \frac{1600k\Omega \cdot kHz}{50kHz} = 32.0k\Omega$$

$$R_{POSC} = \frac{4k\Omega \cdot kHz}{0.160kHz} = 25.0k\Omega$$

## Supply Monitoring

The DS3882 has supply voltage monitors (SVMs) for both the inverter's transformer DC supply ( $V_{INV}$ ) and its own  $V_{CC}$  supply to ensure that both voltage levels are adequate for proper operation. The transformer supply is monitored for overvoltage conditions at the SVMH pin and undervoltage conditions at the SVML pin. External resistor-dividers at each SVM input feed into two comparators (see Figure 7), both having 2V thresholds. Using the equation below to determine the resistor values, the SVMH and SVML trip points ( $V_{TRIP}$ ) can be customized to shut off the inverter when the transformer's supply voltage rises above or drops below specified values. Operating with the transformer's supply at too low of a level can prevent the inverter from

reaching the strike voltage and could potentially cause numerous other problems. Operating with the transformer voltage at too high of a level can be damaging to the inverter components. Proper use of the SVMs can prevent these problems. If desired, the high and/or low SVMs can be disabled by connecting the SVMH pin to GND and the SVML pin to  $V_{CC}$ .

$$V_{TRIP} = 2.0 \left( \frac{R_1 + R_2}{R_1} \right)$$

The  $V_{CC}$  monitor is used as a 5V supply undervoltage lockout (UVLO) that prevents operation when the DS3882 does not have adequate voltage for its analog circuitry to operate or to drive the external MOSFETs. The  $V_{CC}$  monitor features hysteresis to prevent  $V_{CC}$  noise from causing spurious operation when  $V_{CC}$  is near the trip point. This monitor cannot be disabled by any means.

## Fault Monitoring

The DS3882 provides extensive fault monitoring for each channel. It can detect open-lamp, lamp overcurrent, failure to strike, and overvoltage conditions. The DS3882 can be configured to disable all channels if one or more channels enter a fault state or it can be configured to disable only the channel where the fault occurred. Once a fault state has been entered, the  $\overline{FAULT}$  output is asserted and the channel(s) remains disabled until it is reset by a user or host control event. See *Step 4, Fault Handling* for more detail. The DS3882 can also be configured to automatically attempt to clear a detected fault (except lamp overcurrent) by re-striking the lamp. Configuration bits for the fault monitoring options are located in CR1 and CR2. The DS3882 also has real-time status indicators bits located in the SR1 and SR2 register (SRAM) that assert whenever a corresponding fault occurs.

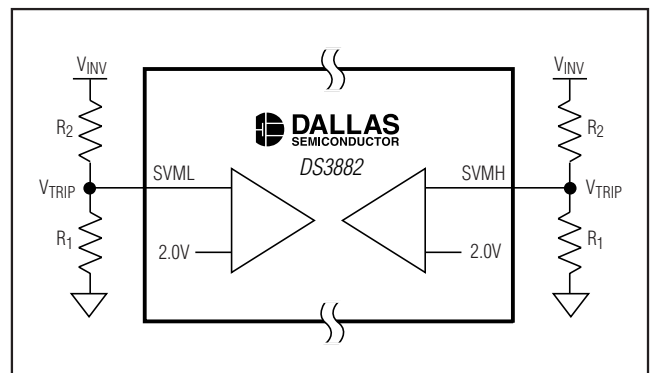

Figure 7. Setting the SVM Threshold Voltage

## Dual-Channel Automotive CCFL Controller

Figure 8 shows a flowchart of how the DS3882 controls and monitors each lamp. The steps are as follows:

- 1) **Supply Check**—The lamps do not turn on unless the DS3882 supply voltage is above 4.3V and the voltage at the supply voltage monitors, SVML and SVMH, are respectively above 2.0V and below 2.0V.
- 2) **Strike Lamp**—When both the DS3882 and the DC inverter supplies are at acceptable levels, the DS3882 attempts to strike each enabled lamp. The DS3882 slowly ramps up the MOSFET gate duty cycle until the lamp strikes. The controller detects that the lamp has struck by detecting current flow in the lamp, detected by the LCMn pin. If during the strike ramp, the maximum allowable voltage is reached on the OVDn pin, the controller stops increasing the MOSFET gate duty cycle to keep from overstressing the system. The DS3882 goes into a fault handling state (step 4) if the lamp has not struck after the timeout period as defined by the LST0 and LST1 control bits in the SSP1 register. If an overvoltage event is detected during the strike attempt, the DS3882 disables the MOSFET gate drivers and go into the fault handling state.
- 3) **Run Lamp**—Once the lamp is struck, the DS3882 adjusts the MOSFET gate duty cycle to optimize the lamp current. The gate duty cycle is always constrained to keep the system from exceeding the maximum allowable lamp voltage. The lamp current sampling rate is user-selectable using the LSR0 and LSR1 bits in CR2. If lamp current ever drops below the lamp out reference point for the period as defined by the LST0 and LST1 control bits in the SSP1 register, then the lamp is considered extinguished. In this case, the MOSFET gate drivers are disabled and the device moves to the fault handling stage.
- 4) **Fault Handling**—During fault handling, the DS3882 performs an optional (user-selectable) automatic retry to attempt to clear all faults except a lamp overcurrent. The automatic retry makes 14 additional attempts to rectify the fault before declaring the channel in a fault state and permanently disabling the channel. Between each of the 14 attempts, the controller waits 1024 lamp cycles. In the case of a lamp overcurrent, the DS3882 instantaneously declares the channel to be in a fault state and permanently disables the channel. The DS3882 can be configured to disable all channels if one or more channels enter a fault state or it can be configured to disable only the channel where the fault occurred. Once a fault state is entered, the channel remains in that state until one of the following occurs:
  - VCC drops below the UVLO threshold.
  - The SVML or SVMH thresholds are crossed.
  - The PDN pin goes high.
  - The PDNE software bit is written to a logic 1.
  - The channel is disabled by the CH1D or CH2D control bit.



# Dual-Channel Automotive CCFL Controller

DS3882

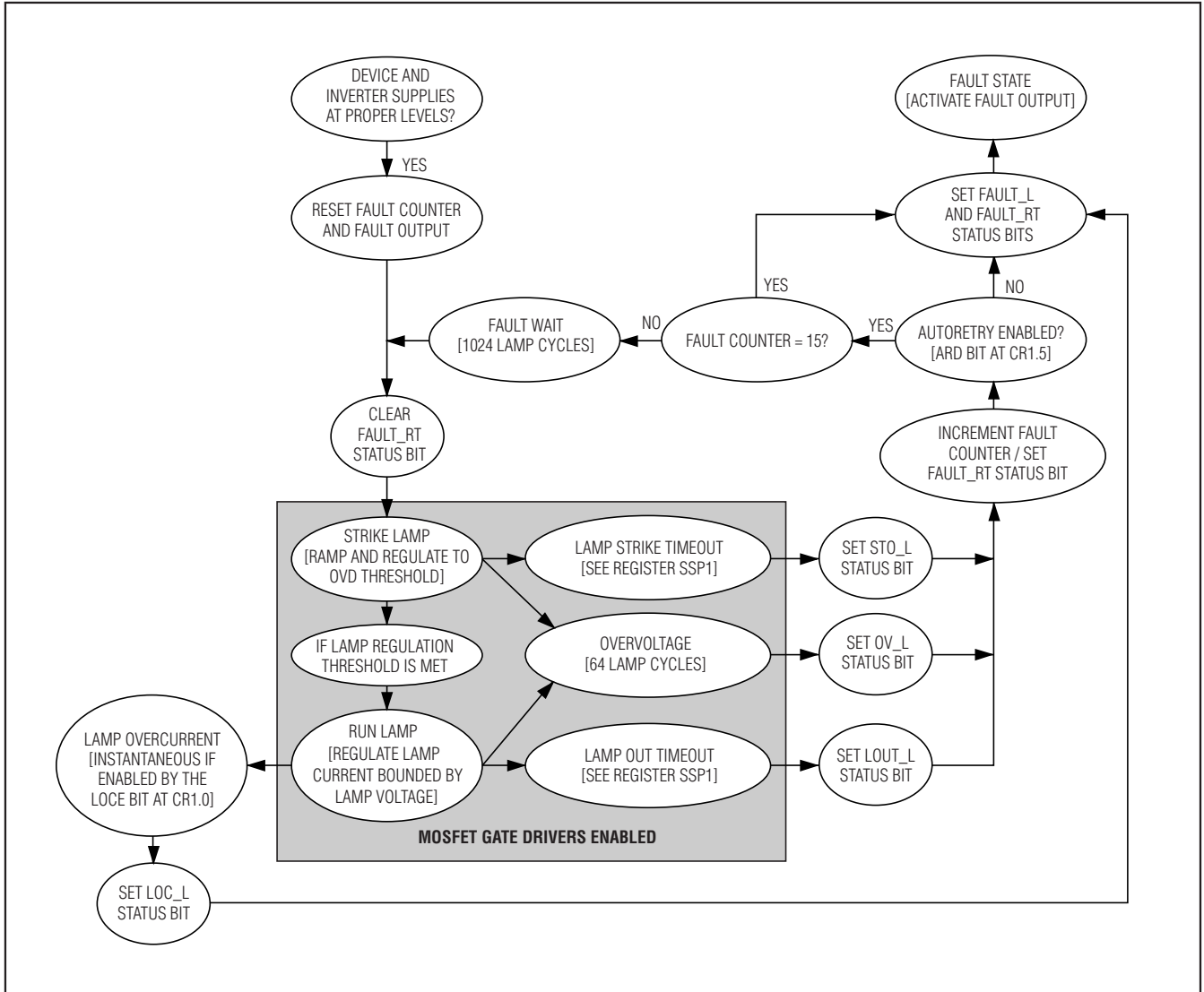

Figure 8. Fault-Handling Flowchart

# Dual-Channel Automotive CCFL Controller

## EMI Suppression Functionality

The DS3882 contains two electromagnetic interference suppression features: spread-spectrum modulation and lamp oscillator frequency stepping. The first is the ability to spread the spectrum of the lamp frequency. By setting either SS0 and/or SS1 in EMIC register, the controller can be configured to dither the lamp frequency by  $\pm 1.5\%$ ,  $\pm 3\%$ , or  $\pm 6\%$ . By setting a non-zero value in SS0/1, spread-spectrum modulation is enabled and oscillator frequency stepping is disabled. In spread-spectrum modulation mode the dither modulation rate is also selectable by setting FS0/1/2, and has either a triangular (SSM = 0) or a pseudorandom profile (SSM = 1). Users have the flexibility to choosing the best modulation rate (through FS0/1/2) for the application.

The second EMI suppression scheme is the ability to move the lamp frequency up or down by 1%, 2%, 3%, or 4%. In this scheme, the actual radiated EMI is not reduced but it is moved out of a sensitive frequency region. STEPE bit and/or STEP pin is used to enable lamp frequency stepping (SS0/1 must be 0). Once enabled, the FS0/1/2 value controls the lamp oscillator frequency shift. For example, if the lamp frequency creates EMI disturbing an audio radio station, it can be moved up or down slightly to slide the spurious interferer out of band.

## Lamp Current Overdrive Functionality

Another feature the DS3882 offers is the ability to overdrive the lamps to allow them to heat up quickly in cold environments. After setting the LCO0/1/2 bits in the LCOC register and enabling the LCOE bit or LCO pin, the DS3882 overdrives the nominal current settings in 12.5% steps from 112.5% up to 200%. The DS3882 accomplishes this by automatically shifting the lamp regulation threshold,  $V_{LRT}$ , upward to allow more current to flow in the lamps (Figure 2). This multilevel adjustment makes it possible to slowly decrease the current overdrive (through  $I^2C$ ) after the lamps have warmed up, so the end user does not see any change in brightness when the overdrive is no longer needed. The DS3882 also features an optional timer capable of automatically turning off the current overdrive. This timer is adjustable from approximately 1.5 minutes to 21 minutes (if a 50kHz lamp frequency is used).

## Detailed Register Descriptions

The DS3882's register map is shown in Table 1. Detailed register and bit descriptions follow in the subsequent tables.

**Table 1. Register Map**

BYTE ADDRESS	BYTE NAME	FACTORY DEFAULT	BIT 7	BIT 6	BIT 5	BIT 4	BIT 3	BIT 2	BIT 1	BIT 0
E0h	SR1	00h	SVMH_RT	SVML_RT	LOC_L1	LOUT_L1	OV_L1	STO_L1	FAULT_L1	FAULT_RT1
E1h	SR2	00h	RSVD	RSVD	LOC_L1	LOUT_L2	OV_L2	STO_L2	FAULT_L2	FAULT_RT2
E2h	BPWM	00h	RSVD	PWM6	PWM5	PWM4	PWM3	PWM2	PWM1	PWM0
E3h	BLC	1Fh	SEEB	CH2D	CH1D	LC4	LC3	LC2	LC1	LC0
F0h	SSP1	21h	LST1	MDC code for soft-start lamp cycles 3, 4			LST0	MDC code for soft-start lamp cycles 1, 2		
F1h	SSP2	43h	MDC code for soft-start lamp cycles 7, 8				MDC code for soft-start lamp cycles 5, 6			
F2h	SSP3	65h	MDC code for soft-start lamp cycles 11, 12				MDC code for soft-start lamp cycles 9, 10			
F3h	SSP4	77h	MDC code for soft-start lamp cycles 15, 16				MDC code for soft-start lamp cycles 13, 14			
F4h	CR1	00h	DPD	FRS	ARD	RGSO	DPSS	LFSS	POSCS	LOCE
F5h	CR2	08h	PDNE	RSVD	RSVD	LSR1	LSR0	POSCR1	POSCR0	UMWP
F6h	EMIC	00h	FS2	FS1	FS0	STEPE	RSVD	SSM	SS1	SS0
F7h	LCOC	00h	TO3	TO2	TO1	TO0	LCOE	LCO2	LCO1	LCO0
F8h–FFh	USER	00h	EE	EE	EE	EE	EE	EE	EE	EE

**Note 1:** E0h–E3h are SRAM locations, and F0h–FFh are SRAM-shadowed EEPROM.

**Note 2:** Altering DS3882 configuration during active CCFL operation can cause serious adverse effects.

**Note 3:** The BPWM, BLC, and LCOC registers control both channels of the DS3882.

# Dual-Channel Automotive CCFL Controller

**Table 2. Status Register 1 (SR1) [SRAM, E0h]**

BIT	R/W	POWER-UP DEFAULT	NAME	FUNCTION
0	R	0	FAULT_RT	Fault Condition—Real Time. A real-time bit that indicates the current operating status of channel 1. 0 = Normal condition 1 = Fault condition
1	R	0	FAULT_L	Fault Condition—Latched. A latched bit that is set when the channel enters a fault condition. This bit is cleared when read, regardless of the current state of fault.
2	R	0	STO_L	Lamp Strike Timeout—Latched. A latched bit that is set when the lamp fails to strike. This bit is cleared when read.
3	R	0	OV_L	Overvoltage—Latched. A latched bit that is set when a lamp overvoltage is present for at least 64 lamp cycles. This bit is cleared when read.
4	R	0	LOUT_L	Lamp Out—Latched. A latched bit that is set when a lamp out is detected. This bit is cleared when read.
5	R	0	LOC_L	Lamp Overcurrent—Latched. A latched bit that is set when a lamp overcurrent is detected. This bit is cleared when read.
6	R	0	SVML_RT	Supply Voltage Monitor Low—Real Time. A real-time bit that reports the comparator output of the SVML pin.
7	R	0	SVMH_RT	Supply Voltage Monitor High—Real Time. A real-time bit that reports the comparator output of the SVMH pin.

**Note 1:** Writing to this register has no effect on it.

**Note 2:** See Figure 8 for more details on how the status bits are set.

**Note 3:** SR1 is cleared when any of the following occurs:

- VCC drops below the UVLO threshold
- the SVML or SVMH thresholds are crossed
- the PDN hardware pin goes high
- the PDNE software bit is written to a logic 1
- the channel is disabled by the CH1D control bit

# Dual-Channel Automotive CCFL Controller

**Table 3. Status Register 2 (SR2) [SRAM, E1h]**

BIT	R/W	POWER-UP DEFAULT	NAME	FUNCTION
0	R	0	FAULT_RT	Fault Condition—Real Time. A real-time bit that indicates the current operating status of channel 2. 0 = Normal condition 1 = Fault condition
1	R	0	FAULT_L	Fault Condition—Latched. A latched bit that is set when the channel enters a fault condition. This bit is cleared when read regardless of the current state of fault.
2	R	0	STO_L	Lamp Strike Time Out—Latched. A latched bit that is set when the lamp fails to strike. This bit is cleared when read.
3	R	0	OV_L	Overvoltage—Latched. A latched bit that is set when a lamp overvoltage is present for at least 64 lamp cycles. This bit is cleared when read.
4	R	0	LOUT_L	Lamp Out—Latched. A latched bit that is set when a lamp out is detected. This bit is cleared when read.
5	R	0	LOC_L	Lamp Overcurrent—Latched. A latched bit that is set when a lamp overcurrent is detected. This bit is cleared when read.
6	R	0	RSVD	Reserved. Could be either 0 or 1 when read.
7	R	0	RSVD	Reserved. Could be either 0 or 1 when read.

**Note 1:** Writing to this register has no effect on it.

**Note 2:** See Figure 8 for more details on how the status bits are set.

**Note 3:** SR2 is cleared when any of the following occurs:

- V<sub>CC</sub> drops below the UVLO threshold
- the SVM<sub>L</sub> or SVM<sub>H</sub> thresholds are crossed
- the PDN hardware pin goes high
- the PDNE software bit is written to a logic 1
- the channel is disabled by the CH2D control bit

**Table 4. Brightness Lamp Current Register (BLC) [SRAM, E3h]**

BIT	R/W	FACTORY DEFAULT	NAME	FUNCTION
0	R/W	0	LC0	These five control bits determine the target value for the lamp current. 11111b is 35% of the nominal level and 00000b is 100% of the nominal level. These control bits are used for fine adjustment of the lamp brightness.
1	R/W	0	LC1	
2	R/W	0	LC2	
3	R/W	0	LC3	
4	R/W	0	LC4	
5	R/W	0	CH1D	Channel 1 Disable 0 = Channel 1 enabled 1 = Channel 1 disabled
6	R/W	0	CH2D	Channel 2 Disable. Useful for dimming in two lamp applications. 0 = Channel 2 enabled 1 = Channel 2 disabled
7	R/W	0	SEEB	SRAM-Shadowed EEPROM Write Control 0 = Enables writes to EEPROM 1 = Disables writes to EEPROM

# Dual-Channel Automotive CCFL Controller

DS3882

**Table 5a. Soft-Start Protocol Registers (SSPx) [Shadowed-EEPROM, F0h, F1h, F2h, F3h]**

SSP#	ADDR	FACTORY DEFAULT	MSB				LSB			
			7	6	5	4	3	2	1	0
SSP1	F0h	21h	LST1	Lamp Cycles 3 and 4		LST0	Lamp Cycles 1 and 2			
SSP2	F1h	43h	RSVD	Lamp Cycles 7 and 8		RSVD	Lamp Cycles 5 and 6			
SSP3	F2h	65h	RSVD	Lamp Cycles 11 and 12		RSVD	Lamp Cycles 9 and 10			
SSP4	F3h	77h	RSVD	Lamp Cycles 15 and 16		RSVD	Lamp Cycles 13 and 14			

**Table 5b. MOSFET Duty Cycle (MDC)—Codes for Soft-Start Settings**

BIT	R/W	NAME	FUNCTION			
0	R/W	MDC0	MDC0/1/2: These bits determine a MOSFET duty cycle that will repeat twice in the 16 lamp cycle soft-start.			
1	R/W	MDC1				
2	R/W	MDC2	<b>MDC CODE</b>	<b>MOSFET DUTY CYCLE</b>	<b>MDC CODE</b>	<b>MOSFET DUTY CYCLE</b>
			0h	Fixed at 0%	4h	Fixed at 13%
			1h	Fixed at 3%	5h	Fixed at 16%
			2h	Fixed at 6%	6h	Fixed at 19%
3	R/W	LST0 / RSVD	3h	Fixed at 9%	7h	Most Recent Value
4	R/W	MDC0	LST0/1: These bits select strike and lamp-out timeout. LST0 and LST1 control fault behavior for all lamps.			
5	R/W	MDC1	<b>LST1</b>	<b>LST0</b>	<b>STRIKE AND LAMP-OUT TIMEOUT (LAMP FREQUENCY CYCLES)</b>	<b>EXAMPLE TIMEOUT IF LAMP FREQUENCY IS 50kHz</b>
6	R/W	MDC2	0	0	32,768	0.66 Seconds
			0	1	65,536	1.31 Seconds
			1	0	98,304	1.97 Seconds
7	R/W	LST1 / RSVD	1	1	Reserved	—

# Dual-Channel Automotive CCFL Controller

DS3882

**Table 6. Control Register 1 (CR1) [Shadowed-EEPROM, F4h]**

BIT	R/W	FACTORY DEFAULT	NAME	FUNCTION
0	R/W	0	LOCE	Lamp Overcurrent Enable 0 = Lamp overcurrent detection disabled. 1 = Lamp overcurrent detection enabled.
1	R/W	0	POSCS	POSC Select. See POSCR0 and POSCR1 control bits in Control Register 2 to select the oscillator range. 0 = POSC input is connected with a resistor to ground to set the frequency of the internal PWM oscillator. 1 = POSC input is a 22.5Hz to 440Hz clock.
2	R/W	0	LFSS	Lamp Frequency Source Select 0 = Lamp frequency generated internally and sourced from the LSYNC output. 1 = Lamp frequency generated externally and supplied to the LSYNC input.
3	R/W	0	DPSS	DPWM Signal Source Select 0 = DPWM signal generated internally and sourced from the PSYNC output. 1 = DPWM signal generated externally and supplied to the PSYNC input.
4	R/W	0	RGSO	Ramp Generator Source Option 0 = Source DPWM at the PSYNC output. 1 = Source internal ramp generator at the PSYNC output.
5	R/W	0	ARD	Autoretry Disable 0 = Autoretry function enabled. 1 = Autoretry function disabled.
6	R/W	0	FRS	Fault Response Select 0 = Disable only the malfunctioning channel. 1 = Disable both channels upon fault detection on any channel.
7	R/W	0	DPD	DPWM Disable 0 = DPWM function enabled. 1 = DPWM function disabled.

# Dual-Channel Automotive CCFL Controller

DS3882

**Table 7. Control Register 2 (CR2) [Shadowed-EEPROM, F5h]**

BIT	R/W	DEFAULT	NAME	FUNCTION																				
0	R/W	0	UMWP	User Memory Write Protect 0 = Write access blocked. 1 = Write access permitted.																				
1	R/W	0	POSCR0	<p>DPWM Oscillator Range Select. When using an external source for the dimming clock, these bits must be set to match the external oscillator's frequency. When using a resistor to set the dimming frequency, these bits plus the external resistor control the frequency.</p> <table border="1"> <thead> <tr> <th>POSCR1</th> <th>POSCR0</th> <th>DIMMING CLOCK (DPWM) FREQUENCY RANGE (Hz)</th> <th>k (kΩ • kHz)</th> </tr> </thead> <tbody> <tr> <td>0</td> <td>0</td> <td>22.5 to 55.0</td> <td>1</td> </tr> <tr> <td>0</td> <td>1</td> <td>45 to 110</td> <td>2</td> </tr> <tr> <td>1</td> <td>0</td> <td>90 to 220</td> <td>4</td> </tr> <tr> <td>1</td> <td>1</td> <td>180 to 440</td> <td>8</td> </tr> </tbody> </table>	POSCR1	POSCR0	DIMMING CLOCK (DPWM) FREQUENCY RANGE (Hz)	k (kΩ • kHz)	0	0	22.5 to 55.0	1	0	1	45 to 110	2	1	0	90 to 220	4	1	1	180 to 440	8
POSCR1	POSCR0	DIMMING CLOCK (DPWM) FREQUENCY RANGE (Hz)	k (kΩ • kHz)																					
0	0	22.5 to 55.0	1																					
0	1	45 to 110	2																					
1	0	90 to 220	4																					
1	1	180 to 440	8																					
2	R/W	0	POSCR1																					
3	R/W	1	LSR0	<p>Lamp Sample Rate Select. Determines the feedback sample rate of the LCM inputs.</p> <table border="1"> <thead> <tr> <th>LSR1</th> <th>LSR0</th> <th>SELECTED LAMP SAMPLE RATE</th> <th>EXAMPLE SAMPLE RATE IF LAMP FREQUENCY IS 50kHz</th> </tr> </thead> <tbody> <tr> <td>0</td> <td>0</td> <td>4 Lamp Frequency Cycles</td> <td>12,500Hz</td> </tr> <tr> <td>0</td> <td>1</td> <td>8 Lamp Frequency Cycles</td> <td>6,250Hz</td> </tr> <tr> <td>1</td> <td>0</td> <td>16 Lamp Frequency Cycles</td> <td>3,125Hz</td> </tr> <tr> <td>1</td> <td>1</td> <td>32 Lamp Frequency Cycles</td> <td>1,563Hz</td> </tr> </tbody> </table>	LSR1	LSR0	SELECTED LAMP SAMPLE RATE	EXAMPLE SAMPLE RATE IF LAMP FREQUENCY IS 50kHz	0	0	4 Lamp Frequency Cycles	12,500Hz	0	1	8 Lamp Frequency Cycles	6,250Hz	1	0	16 Lamp Frequency Cycles	3,125Hz	1	1	32 Lamp Frequency Cycles	1,563Hz
LSR1	LSR0	SELECTED LAMP SAMPLE RATE	EXAMPLE SAMPLE RATE IF LAMP FREQUENCY IS 50kHz																					
0	0	4 Lamp Frequency Cycles	12,500Hz																					
0	1	8 Lamp Frequency Cycles	6,250Hz																					
1	0	16 Lamp Frequency Cycles	3,125Hz																					
1	1	32 Lamp Frequency Cycles	1,563Hz																					
4	R/W	0	LSR1																					
5	—	0	RSVD	Reserved. This bit should be set to zero.																				
6	—	0	RSVD	Reserved. This bit should be set to zero.																				
7	R/W	0	PDNE	Power-Down. Logically ORed with the PDN pin. Setting this bit high resets the controller, clears the fault logic, and places the part in power-down mode. 0 = Normal. All circuitry is off, except I <sup>2</sup> C interface.																				

# Dual-Channel Automotive CCFL Controller

**Table 8. EMI Control Register (EMIC) [Shadowed-EEPROM, F6h]**

BIT	R/W	FACTORY DEFAULT	NAME	FUNCTION				
0	R/W	0	SS0	<b>LAMP OSCILLATOR SPREAD-SPECTRUM MODULATION SELECT</b>				
				<b>SS1</b>	<b>SS0</b>	<b>SELECTED LAMP FREQUENCY SPREAD</b>		
				0	0	Spread-Spectrum Disabled		
1	R/W	0	SS1	0	1	±1.5%		
				1	0	±3.0%		
				1	1	±6.0%		
2	R/W	0	SSM	Lamp Oscillator Spread-Spectrum Modulation Select 0 = Triangular modulation. 1 = Pseudorandom modulation.				
3	—	—	RSVD	Reserved. This bit should be set to zero.				
4	R/W	0	STEPE	Lamp Frequency Step Enable. Logically ORed with the Step Invoked. 0 = Lamp operates at nominal frequency. 1 = Frequency step invoked.				
5	R/W	0	FS0	<b>LAMP OSCILLATOR FREQUENCY STEP SELECT</b>				
				<b>FS2</b>	<b>FS1</b>	<b>FS0</b>	<b>SELECTED LAMP FREQUENCY STEP (SS0 = 0 AND SS1 = 0)</b>	<b>SPREAD-SPECTRUM MODULATION RATE (SS0 AND/OR SS1 = 1)</b>
				0	0	0	Step Up 1%	Lamp Frequency x4
6	R/W	0	FS1	0	0	1	Step Up 2%	Lamp Frequency x2
				0	1	0	Step Up 3%	Lamp Frequency x1
				0	1	1	Step Up 4%	Lamp Frequency x1/2
				1	0	0	Step Down 1%	Lamp Frequency x1/4
				1	0	1	Step Down 2%	Lamp Frequency x1/8
7	R/W	0	FS2	1	1	0	Step Down 3%	Lamp Frequency x1/16
				1	1	1	Step Down 4%	Lamp Frequency x1/32



# Dual-Channel Automotive CCFL Controller

DS3882

**Table 9. Lamp Current Overdrive Control Register (LCOC) [Shadowed-EEPROM, F7h]**

BIT	R/W	FACTORY DEFAULT	NAME	FUNCTION					
0	R/W	0	LCO0	LAMP CURRENT OVERDRIVE SELECT					
				LCO2	LCO1	LCO0	SELECTED LAMP CURRENT OVERDRIVE		
				0	0	0	Nominal Current + 12.50%		
				0	0	1	Nominal Current + 25.00%		
1	R/W	0	LCO1	0	1	0	Nominal Current + 37.50%		
				0	1	1	Nominal Current + 50.00%		
				1	0	0	Nominal Current + 62.50%		
2	R/W	0	LCO2	1	0	1	Nominal Current + 75.00%		
				1	1	0	Nominal Current + 87.50%		
				1	1	1	Nominal Current + 100.00%		
3	R/W	0	LCOE	Lamp Current Overdrive Enable. Logically ORed with the LCO pin. 0 = Lamp operated with nominal current setting. 1 = Lamp overdrive invoked.					
4	R/W	0	TO0	AUTOMATIC LAMP CURRENT OVERDRIVE TIMEOUT SELECT					
				TO3	TO2	TO1	TO0	SELECTED TIMEOUT IN LAMP FREQUENCY CYCLES	EXAMPLE TIMEOUT IF LAMP FREQUENCY IS 50kHz
5	R/W	0	TO1	0	0	0	1	$1 \times 2^{22}$	1.4 min
				0	0	1	0	$2 \times 2^{22}$	2.8 min
				0	0	1	1	$3 \times 2^{22}$	4.2 min
				0	1	0	0	$4 \times 2^{22}$	5.6 min
				0	1	0	1	$5 \times 2^{22}$	7.0 min
6	R/W	0	TO2	0	1	1	0	$6 \times 2^{22}$	8.4 min
				0	1	1	1	$7 \times 2^{22}$	9.8 min
				1	0	0	0	$8 \times 2^{22}$	11.2 min
				1	0	0	1	$9 \times 2^{22}$	12.6 min
				1	0	1	0	$10 \times 2^{22}$	14.0 min
7	R/W	0	TO3	1	0	1	1	$11 \times 2^{22}$	15.4 min
				1	1	0	0	$12 \times 2^{22}$	16.8 min
				1	1	0	1	$13 \times 2^{22}$	18.2 min
				1	1	1	0	$14 \times 2^{22}$	19.6 min
				1	1	1	1	$15 \times 2^{22}$	21.0 min

# Dual-Channel Automotive CCFL Controller

## I<sup>2</sup>C Definitions

The following terminology is commonly used to describe I<sup>2</sup>C data transfers:

**Master Device:** The master device controls the slave devices on the bus. The master device generates SCL clock pulses, start, and stop conditions.

**Slave Devices:** Slave devices send and receive data at the master's request.

**Bus Idle or Not Busy:** Time between stop and start conditions when both SDA and SCL are inactive and in their logic-high states.

**Start Condition:** A start condition is generated by the master to initiate a new data transfer with a slave. Transitioning SDA from high to low while SCL remains high generates a start condition. See the timing diagram for applicable timing.

**Stop Condition:** A stop condition is generated by the master to end a data transfer with a slave. Transitioning SDA from low to high while SCL remains high generates a stop condition. See the timing diagram for applicable timing.

**Repeated Start Condition:** The master can use a repeated start condition at the end of one data transfer to indicate that it will immediately initiate a new data transfer following the current one. Repeated starts are commonly used during read operations to identify a specific memory address to begin a data transfer. A repeated start condition is issued identically to a normal start condition. See the timing diagram for applicable timing.

**Bit Write:** Transitions of SDA must occur during the low state of SCL. The data on SDA must remain valid and unchanged during the entire high pulse of SCL plus the setup and hold time requirements (see Figure 9). Data is shifted into the device during the rising edge of the SCL.

**Bit Read:** At the end of a write operation, the master must release the SDA bus line for the proper amount of setup time (see Figure 9) before the next rising edge of SCL during a bit read. The device shifts out each bit of data on SDA at the falling edge of the previous SCL pulse and the data bit is valid at the rising edge of the current SCL pulse. Remember that the master generates all SCL clock pulses including when it is reading bits from the slave.

**Acknowledgement (ACK and NACK):** An acknowledgement (ACK) or not acknowledge (NACK) is always the 9th bit transmitted during a byte transfer. The device receiving data (the master during a read or the slave during a write operation) performs an ACK by transmitting a zero during the 9th bit. A device performs a NACK by transmitting a one during the 9th bit. Timing (Figure 9) for the ACK and NACK is identical to all other bit writes. An ACK is the acknowledgment that the device is properly receiving data. A NACK is used to terminate a read sequence or as an indication that the device is not receiving data.

**Byte Write:** A byte write consists of 8 bits of information transferred from the master to the slave (most significant bit first) plus a 1-bit acknowledgement from the slave to the master. The 8 bits transmitted by the master are done according to the bit-write definition and the acknowledgement is read using the bit-read definition.

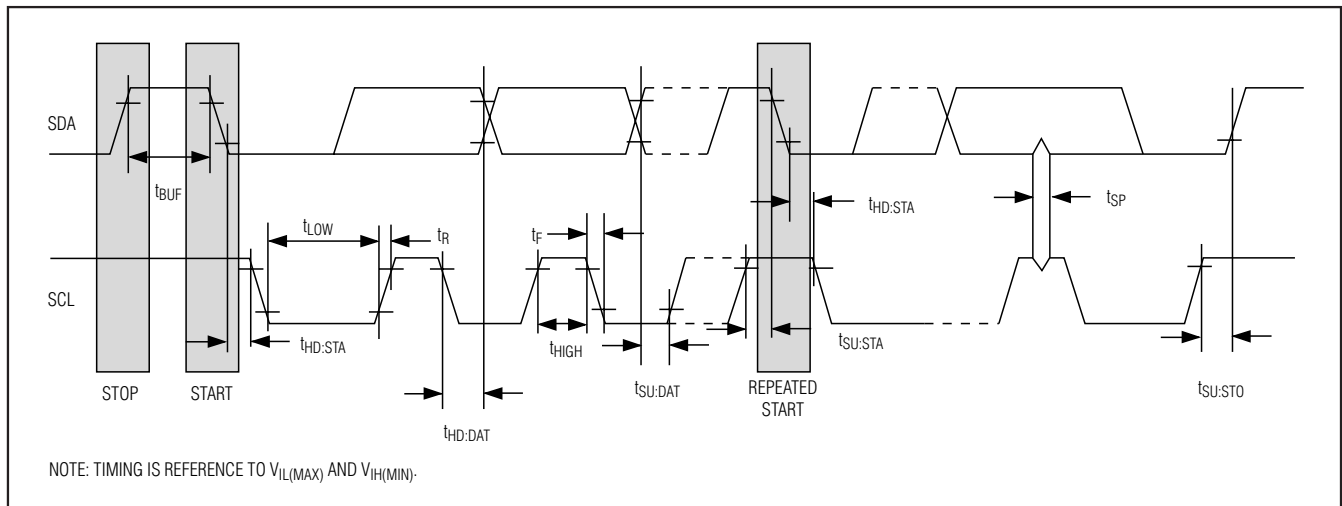

Figure 9. I<sup>2</sup>C Timing Diagram

# Dual-Channel Automotive CCFL Controller

**Byte Read:** A byte read is an 8-bit information transfer from the slave to the master plus a 1-bit ACK or NACK from the master to the slave. The 8 bits of information that are transferred (most significant bit first) from the slave to the master are read by the master using the bit read definition above, and the master transmits an ACK using the bit write definition to receive additional data bytes. The master must NACK the last byte read to terminate communication so the slave will return control of SDA to the master.

**Slave Address Byte:** Each slave on the I<sup>2</sup>C bus responds to a slave addressing byte sent immediately following a start condition. The slave address byte (Figure 10) contains the slave address in the most significant seven bits and the  $\overline{R/W}$  bit in the least significant bit. The DS3882's slave address is 10100A<sub>1</sub>A<sub>0</sub>0 (binary), where A<sub>0</sub> and A<sub>1</sub> are the values of the address pins (A0 and A1). The address pin allows the device to respond to one of four possible slave addresses. By writing the correct slave address with  $\overline{R/W} = 0$ , the master indicates it will write data to the slave. If  $\overline{R/W} = 1$ , the master will read data from the slave. If an incorrect slave address is written, the DS3882 will assume the master is communicating with another I<sup>2</sup>C device and ignore the communications until the next start condition is sent.

**Memory Address:** During an I<sup>2</sup>C write operation, the master must transmit a memory address to identify the memory location where the slave is to store the data. The memory address is always the second byte transmitted during a write operation following the slave address byte.

## I<sup>2</sup>C Communication

**Writing a Data Byte to a Slave:** The master must generate a start condition, write the slave address byte ( $\overline{R/W} = 0$ ), write the memory address, write the byte of data, and generate a stop condition. Remember the master must read the slave's acknowledgement during all byte write operations. See Figure 11 for more detail.

**Acknowledge Polling:** Any time EEPROM is written, the DS3882 requires the EEPROM write time ( $t_{W}$ ) after the stop condition to write the contents to EEPROM. During the EEPROM write time, the DS3882 will not acknowledge its slave address because it is busy. It is possible to take advantage of that phenomenon by repeatedly addressing the DS3882, which allows the next byte of data to be written as soon as the DS3882 is ready to receive the data. The alternative to acknowledge polling is to wait for a maximum period of  $t_{W}$  to elapse before attempting to write again to the DS3882.

**EEPROM Write Cycles:** The number of times the DS3882's EEPROM can be written before it fails is specified in the *Nonvolatile Memory Characteristics* table. This specification is shown at the worst-case write temperature. The DS3882 is typically capable of handling many additional write cycles when the writes are performed at room temperature.

**Reading a Data Byte from a Slave:** To read a single byte from the slave the master generates a start condition, writes the slave address byte with  $\overline{R/W} = 0$ , writes the memory address, generates a repeated start condition, writes the slave address with  $\overline{R/W} = 1$ , reads the data byte with a NACK to indicate the end of the transfer, and generates a stop condition. See Figure 11 for more detail.

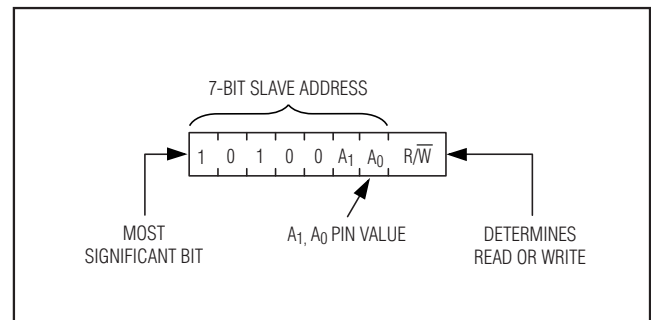

Figure 10. DS3882's Slave Address Byte

# Dual-Channel Automotive CCFL Controller

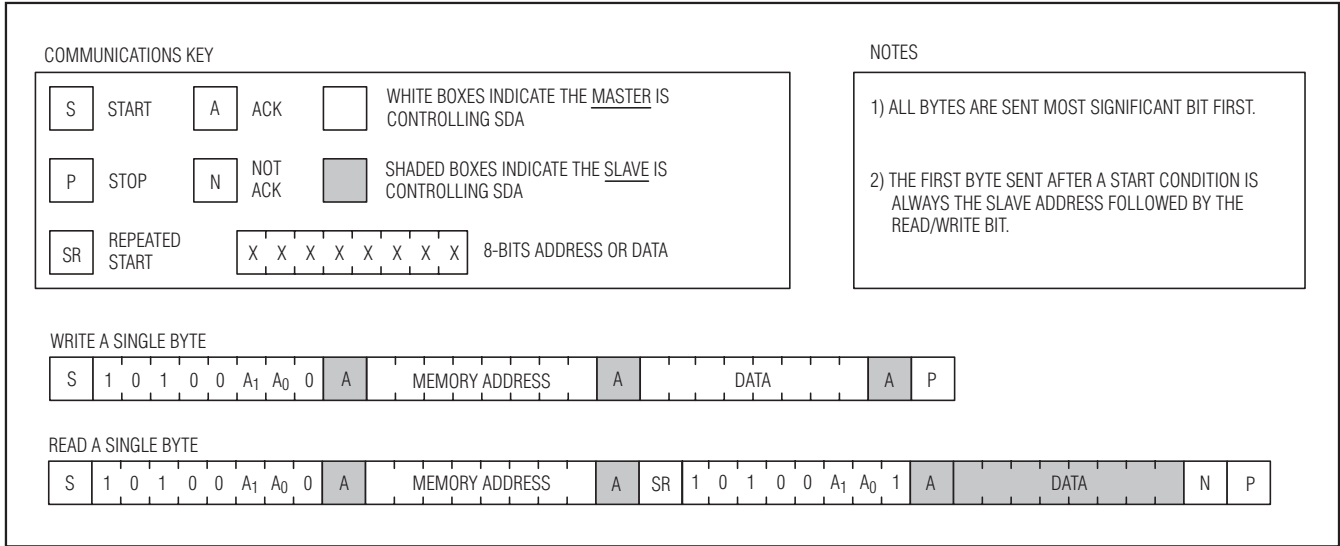

Figure 11. I<sup>2</sup>C Communications Examples

## Applications Information

### Addressing Multiple DS3882s On a Common I<sup>2</sup>C Bus

Each DS3882 responds to one of four possible slave addresses based on the state of the address input pins (A0 and A1). For information about device addressing, see the *I<sup>2</sup>C Communication* section.

### Setting the RMS Lamp Current

Resistor R7 and R8 in the *Typical Operating Circuit* set the lamp current. R7 and R8 = 140Ω corresponds to a 5mA<sub>RMS</sub> lamp current as long as the current waveform is approximately sinusoidal. The formula to determine the resistor value for a given sinusoidal lamp current is:

$$R_{7/8} = \frac{1}{I_{LAMP(RMS)} \times \sqrt{2}}$$

### Component Selection

External component selection has a large impact on the overall system performance and cost. The two most important external components are the transformers and n-channel MOSFETs.

The transformer should be able to operate in the 40kHz to 80kHz frequency range of the DS3882, and the turns

ratio should be selected so the MOSFET drivers run at 28% to 35% duty cycle during steady state operation. The transformer must be able to withstand the high open-circuit voltage that is used to strike the lamp. Additionally, its primary/secondary resistance and inductance characteristics must be considered because they contribute significantly to determining the efficiency and transient response of the system. Table 10 shows a transformer specification that has been used for a 12V inverter supply, 438mm x 2.2mm lamp design.

The n-channel MOSFET must have a threshold voltage that is low enough to work with logic-level signals, a low on-resistance to maximize efficiency and limit the n-channel MOSFET's power dissipation, and a breakdown voltage high enough to handle the transient. The breakdown voltage should be a minimum of 3x the inverter voltage supply. Additionally, the total gate charge must be less than Q<sub>G</sub>, which is specified in the *Recommended Operating Conditions* table. These specifications are easily met by many of the dual n-channel MOSFETs now available in 8-pin SO packages.

Table 11 lists suggested values for the external resistors and capacitors used in the *Typical Operating Circuit*.

# Dual-Channel Automotive CCFL Controller

DS3882

**Table 10. Transformer Specifications (as Used in the Typical Operating Circuit)**

PARAMETER	CONDITIONS	MIN	TYP	MAX	UNITS
Turns Ratio (Secondary/Primary)	(Notes 1, 2, 3)		40		
Frequency		40		80	kHz
Output Power				6	W
Output Current			5	8	mA
Primary DCR	Center tap to one end		200		mΩ
Secondary DCR			500		Ω
Primary Leakage			12		μH
Secondary Leakage			185		mH
Primary Inductance			70		μH
Secondary Inductance			500		mH
Secondary Output Voltage	100ms minimum	2000			V <sub>RMS</sub>
	Continuous	1000			

**Note 1:** Primary should be Bifilar wound with center tap connection.

**Note 2:** Turns ratio is defined as secondary winding divided by the sum of both primary windings.

**Note 3:** 40:1 is the nominal turns ratio for driving a 438mm x 2.2mm lamp with a 12V supply. Refer to Application Note 3375 for more information.

**Table 11. Resistor and Capacitor Selection Guide**

DESIGNATOR	QTY	VALUE	TOLERANCE (%) AT +25°C	TEMPERATURE COEFFICIENT	NOTES
R5, R6	1	10kΩ	1	—	—
R3, R4	1	12.5kΩ to 105kΩ	1	—	See the <i>Setting the SVM Threshold Voltage</i> section.
R9	1	20kΩ to 40kΩ	1	≤153ppm/°C	2% or less total tolerance. See the <i>Lamp Frequency Configuration</i> section to determine value.
R10	1	18kΩ to 45kΩ	1	≤153ppm/°C	2% or less total tolerance. See the <i>Lamp Frequency Configuration</i> section to determine value.
R1	1	4.7kΩ	5	Any grade	—
R2	1	4.7kΩ	5	Any grade	—
R11	1	4.7kΩ	5	Any grade	—
R7, R8	1/Chan	140Ω	1	—	See the <i>Setting the RMS Lamp Current</i> section.
C6, C8	1/Chan	100nF	10	X7R	Capacitor value will also affect LCM bias voltage during power-up. A larger capacitor may cause a longer time for V <sub>DCB</sub> to reach its normal operating level.
C2	1/Chan	10pF	5	±1000ppm/°C	2kV to 4kV breakdown voltage required.
C3	1/Chan	27nF	5	X7R	Capacitor value will also affect LCM bias voltage during power-up. A larger capacitor may cause a longer time for V <sub>DCB</sub> to reach its normal operating level.
C1	1/Chan	33μF	20	Any grade	—
C7	2/DS3882	0.1μF	10	X7R	Place close to V <sub>CC</sub> and GND on DS3882.

# Dual-Channel Automotive CCFL Controller

## Typical Operating Circuit

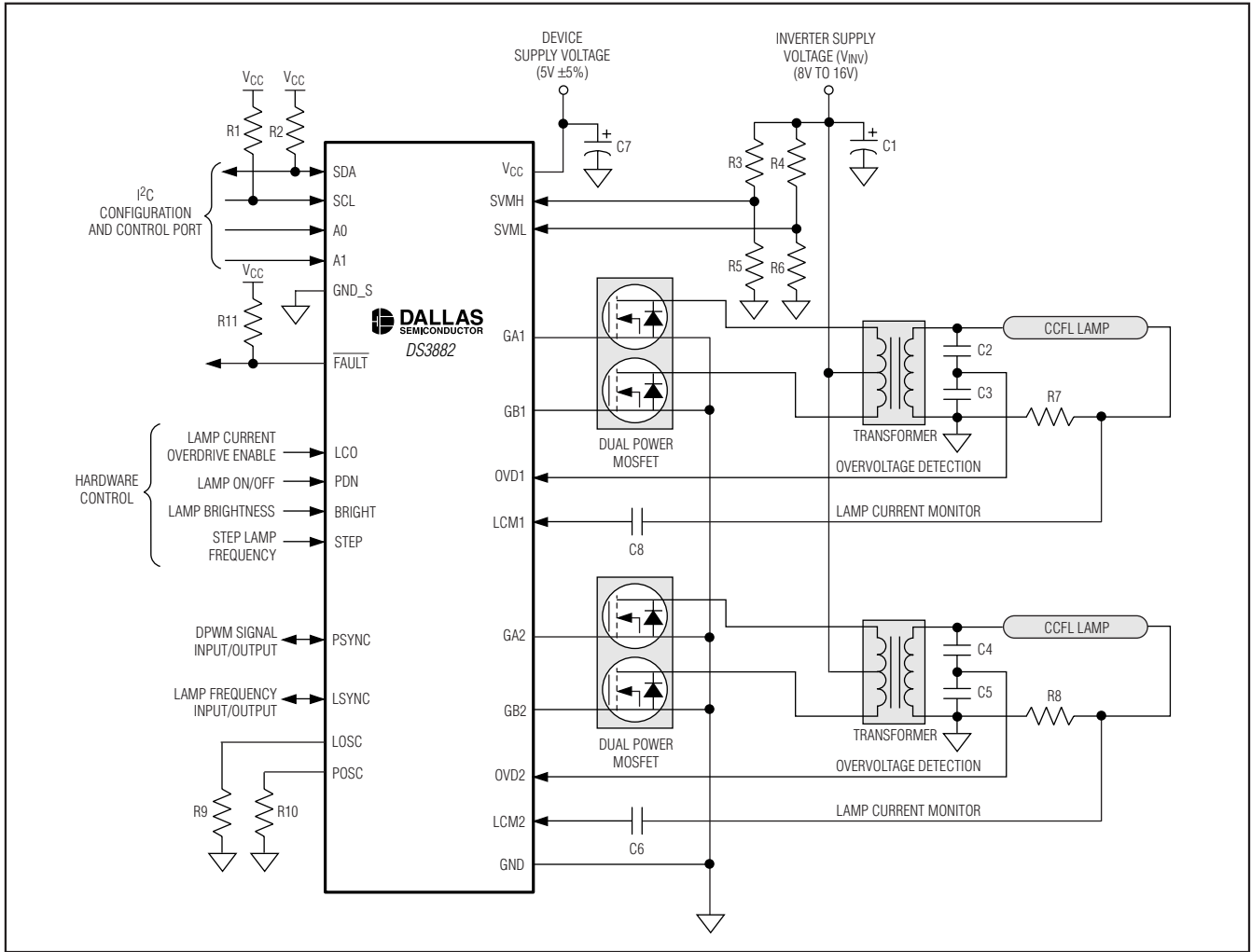

### Power-Supply Decoupling

To achieve best results, it is highly recommended that a decoupling capacitor is used on the IC power-supply pin. Typical values of decoupling capacitors are 0.01 $\mu$ F or 0.1 $\mu$ F. Use a high-quality, ceramic, surface-mount capacitor, and mount it as close as possible to the VCC and GND pins of the IC to minimize lead inductance.

### Chip Information

SUBSTRATE CONNECTED TO GROUND

### Package Information

For the latest package outline information and land patterns, go to [www.maxim-ic.com/packages](http://www.maxim-ic.com/packages). Note that a "+", "#", or "-" in the package code indicates RoHS status only. Package drawings may show a different suffix character, but the drawing pertains to the package regardless of RoHS status.

PACKAGE TYPE	PACKAGE CODE	OUTLINE NO.	LAND PATTERN NO.
28 TSSOP (173 mils)	U28+2	<a href="#">21-0066</a>	<a href="#">90-0171</a>

# Dual-Channel Automotive CCFL Controller

## Revision History

REVISION NUMBER	REVISION DATE	DESCRIPTION	PAGES CHANGED
0	3/06	Initial release	—
1	8/07	Updated Table 5b to change bit 7 LST[1:0] at 1:1 from 131,072 lamp frequency cycles to reserved	21
2	12/10	Updated the <i>Ordering Information</i> table part numbers; added the continuous power dissipation numbers for a single-layer board and the lead and soldering temperature information to the <i>Absolute Maximum Ratings</i> section; added the <i>Package Information</i> table	1, 2, 30

DS3882

Maxim cannot assume responsibility for use of any circuitry other than circuitry entirely embodied in a Maxim product. No circuit patent licenses are implied. Maxim reserves the right to change the circuitry and specifications without notice at any time.

**Maxim Integrated Products, 120 San Gabriel Drive, Sunnyvale, CA 94086 408-737-7600** \_\_\_\_\_ 31

© 2010 Maxim Integrated Products

Maxim is a registered trademark of Maxim Integrated Products, Inc.

 **DALLAS** SEMICONDUCTOR is a registered trademark of Maxim Integrated Products, Inc.