



STP08CDC596

8-Bit constant current Led sink driver with full outputs detection

General features

- 8 constant current output channels
- Adjustable output current through one external resistor
- Open and short line, short to GND, short to V-LED supply error detection
- Serial data in/parallel data out
- Serial out change state on the falling edges of clock
- Output current: 20-120mA
- 3.3V micro driver-able
- 25MHz clock frequency
- Available in high thermal TSSOP exposed pad.

Description

The STP08CDC596 is a monolithic, medium-voltage, low current power 8-bit shift register designed for LED panel display. The STP08CDC596 contains a 8-bit serial-in, parallel-out shift register that feeds a 8-bit D-type storage register. In the output stage, eight regulated current sources were designed to provide 15-120mA constant current to drive the LEDs. The STP08CDC596 contains the built-IN error detection feature. The device performs this additional function without any increase of the pin number and any change of the pin function, if compared to the standard device without error detection. Consequently, choosing this device does not mean to change the footprint on the board.

Order codes

Part Number	Temperature range	Package	Packaging
STP08CDC596B1	-40°C to 125°C	DIP-16	25 part per tube
STP08CDC596M	-40°C to 125°C	SO-16 (Tube)	50 parts per tube
STP08CDC596MTR	-40°C to 125°C	SO-16 (Tape & Reel)	2500 parts per reel
STP08CDC596TTR	-40°C to 125°C	TSSOP16 (Tape & Reel)	2500 parts per reel
STP08CDC596XTTR	-40°C to 125°C	TSSOP16 Exposed pad (Tape & Reel)	2500 parts per reel

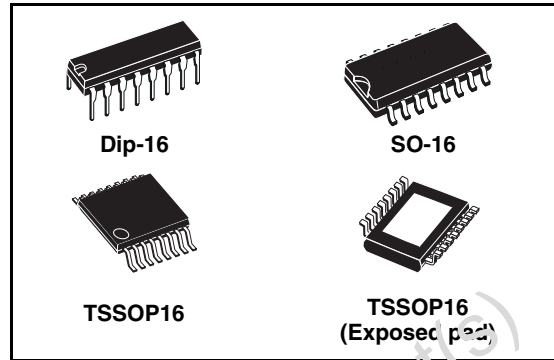

To perform this functionality mode, the device needs a digital key coming from the Microprocessor. The STP08CDC596 is able to detect: open and short on the LED line, short to GND, short to LED voltage supply. The data mapping of output channels status detection is provided by a feedback from the serial output to the Microprocessor.

Through an external resistor, users may adjust the STP08CDC596 output current, controlling the light intensity of LEDs.

The STP08CDC596 guarantees 16V output driving capability, allowing users to connect more LEDs in series. The high clock frequency, 25 MHz, also satisfies the system requirement of high volume data transmission.

The device is offered in DIP-16, SO-16, TSSOP-16 and TSSOP-16 Exposed Pad packages.

The STP08CDC596 is well suitable for traffic display signs where the detection feature is strongly required.

Contents

1	Summary description	3
1.1	Pin connection and description	3
2	Block diagram	4
3	Maximum rating	5
3.1	Absolute maximum ratings	5
3.2	Thermal data	5
3.3	Recommended operating conditions	6
4	Electrical characteristics	7
5	Switching characteristics	8
6	Equivalent circuit of inputs and outputs	9
7	Timing diagram	11
8	Test circuit	14
9	Running the detection mode	16
9.1	Phase one: “entering in detection mode”	16
9.2	Phase two: “error detection”	17
9.3	Phase three: “resuming to normal mode”	18
9.4	Condition in order to get a successfully detection condition	19
10	Typical characteristics	20
11	Package mechanical data	21
12	Revision history	28

1 Summary description

Table 1. Current accuracy

Output voltage	Current accuracy		Output current
	Between bits	Between ICs	
$\geq 0.7V$	(Typ) $\pm 3\%$	$\pm 10\%$	20 to 120mA

1.1 Pin connection and description

Figure 1. Connections diagram

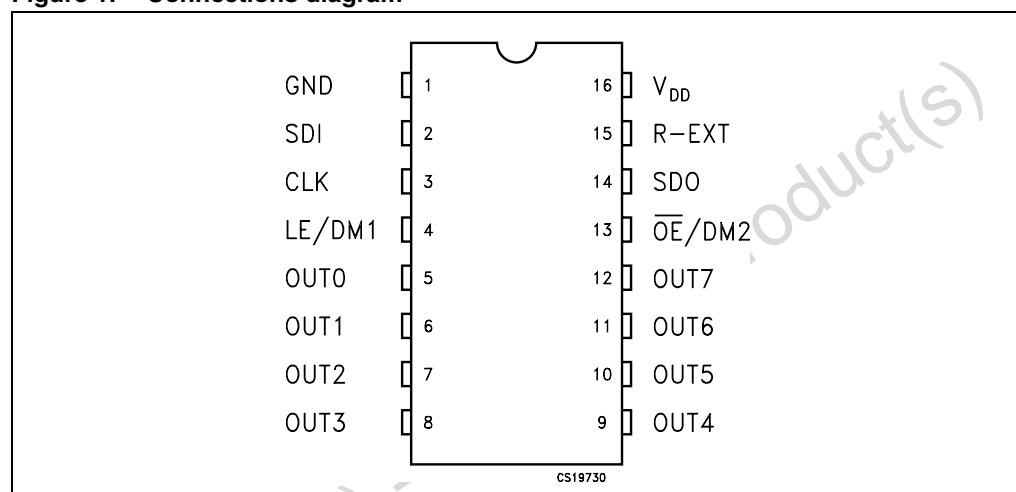
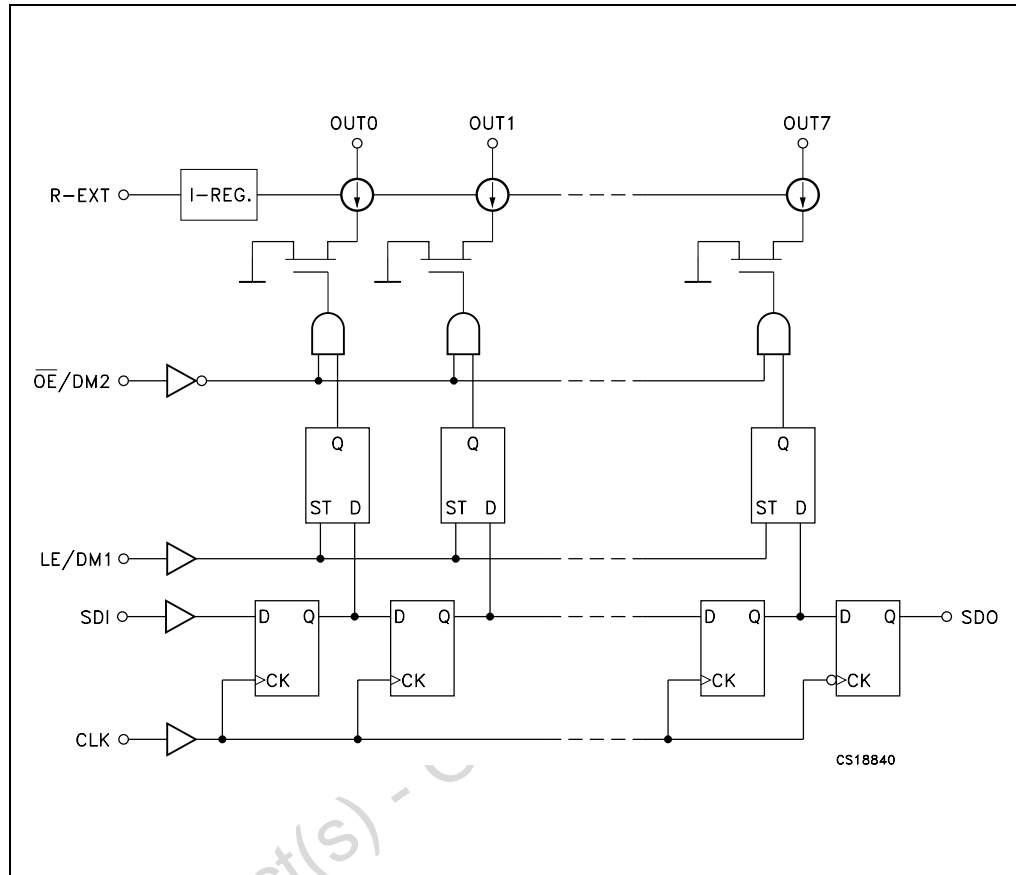

Table 2. Pin description

PIN N°	Symbol	Name and function
1	GND	Ground terminal
2	SDI	Serial data input terminal
3	CLK	Clock input terminal
4	LE/DM1	Latch input terminal
5-12	OUT 0-7	Output terminal
13	$\overline{OE}/DM2$	Output enable input terminal (active low)
14	SDO	Serial data out terminal
15	R-EXT	Constant current programming
16	V_{DD}	5V Supply voltage terminal

2 Block diagram

Figure 2. Block diagram



3 Maximum rating

Stressing the device above the rating listed in the “Absolute Maximum Ratings” table may cause permanent damage to the device. These are stress ratings only and operation of the device at these or any other conditions above those indicated in the Operating sections of this specification is not implied. Exposure to Absolute Maximum Rating conditions for extended periods may affect device reliability. Refer also to the STMicroelectronics SURE Program and other relevant quality documents.

3.1 Absolute maximum ratings

Table 3. Absolute maximum ratings

Symbol	Parameter	Value	Unit
V_{DD}	Supply voltage I_{GND}	0 to 7	V
V_O	Output voltage	-0.5 to 16	V
I_O	Output current	120	mA
V_I	Input voltage	-0.4 to $V_{DD}+0.4$	V
I_{GND}	GND terminal current	980	mA
f_{CLK}	Clock frequency	25	MHz
T_{OPR}	Operating temperature range	-40 to +125	°C
T_{STG}	Storage temperature range	-55 to +150	°C

3.2 Thermal data

Table 4. Thermal data

Symbol	Parameter	Package	Value	Unit
R_{thJA}	Thermal resistance junction-ambient	DIP-16	90	°C/W
		SO-16	125	
		TSSOP-16	140	
		TSSOP-16 Exposed Pad	38 ⁽¹⁾	

1. The exposed pad should be soldered directly to the PCB to realize the thermal benefits.

3.3 Recommended operating conditions

Table 5. Recommended operating conditions

Symbol	Parameter	Test conditions	Min	Typ	Max	Unit
V_{DD}	Supply voltage		3.3		5.5	V
V_O	Output voltage				16.0	V
I_O	Output current	OUTn	15		120	mA
I_{OH}	Output current	SERIAL-OUT			+1	mA
I_{OL}	Output current	SERIAL-OUT			-1	mA
V_{IH}	Input voltage		$0.7V_{DD}$		$V_{DD}+0.3$	V
V_{IL}	Input voltage		-0.3		$0.3V_{DD}$	V
t_{wLAT}	LE/DM1 pulse width	$V_{DD} = 3.0$ to $5.0V$		10	20	ns
t_{wCLK}	CLK pulse width			10	20	ns
t_{wEN}	$\overline{OE}/DM2$ pulse width ⁽¹⁾			120	400	ns
$t_{SETUP(D)}$	Setup time for DATA			5	20	ns
$t_{HOLD(D)}$	Hold time for DATA			4	15	ns
$t_{SETUP(L)}$	Setup time for LATCH			8	15	ns
f_{CLK}	Clock frequency ⁽²⁾					25

1. If the device is connected in cascade, it may not be possible to achieve the maximum data transfer. Please consider the timings carefully.
2. In normal mode the $\overline{OE}/DM2$ must remain low at least two clock cycles.

4 Electrical characteristics

Table 6. Electrical characteristics ($V_{DD} = 5V$, $T = 25^{\circ}C$, unless otherwise specified.)

Symbol	Parameter	Test conditions	Min	Typ	Max	Unit
V_{IH}	Input voltage high level		$0.7V_{DD}$		V_{DD}	V
V_{IL}	Input voltage low level		GND		$0.3V_{DD}$	V
I_{OH}	Output leakage current	$V_{OH} = 16V$			10	μA
V_{OL}	Output voltage (Serial-OUT)	$I_{OL} = 1mA$			0.4	V
V_{OH}	Output voltage (Serial-OUT)	$I_{OH} = -1mA$	$V_{DD}-0.4V$			V
I_{OL1}	Output current	$V_O = 0.7VR_{EXT} = 910 \Omega$	18.8	20.9	24.00	mA
I_{OL2}		$V_O = 0.7VR_{EXT} = 360 \Omega$	46.00	51.5	56.5	
ΔI_{OL1}	Output current error between bit (All Output ON)	$V_O = 0.7VR_{EXT} = 910 \Omega$		± 2	± 5	%
ΔI_{OL2}		$V_O = 0.7VR_{EXT} = 360 \Omega$		± 1	± 4	
$R_{SIN(up)}$	Pull-up resistor		150	300	600	$K\Omega$
$R_{SIN(down)}$	Pull-down resistor		100	200	400	$K\Omega$
$I_{DD(OFF1)}$	Supply current (OFF)	$R_{EXT} = OPEN$ OUT 0 to 7 = OFF		0.45	0.7	mA
$I_{DD(OFF2)}$		$R_{EXT} = 910 \Omega$ OUT 0 to 7 = OFF		3.0	6.0	
$I_{DD(OFF3)}$		$R_{EXT} = 360 \Omega$ OUT 0 to 7 = OFF		8.2	12.0	
$I_{DD(ON1)}$	Supply current (ON)	$R_{EXT} = 910 \Omega$ OUT 0 to 7 = ON		3.1	6.2	
$I_{DD(ON2)}$		$R_{EXT} = 360 \Omega$ OUT 0 to 7 = ON		8.4	12.8	

5 Switching characteristics

Table 7. Switching Characteristics ($V_{DD} = 3.3V$ to $5.5V$, $T = 25^{\circ}C$, unless otherwise specified.)

Symbol	Parameter	Test conditions	Min	Typ	Max	Unit	
t_{PLH1}	Propagation delay time, CLK- \overline{OUTn} , $\overline{LE}/DM1 = H$, $\overline{OE}/DM2 = L$	$V_{DD} = 3V$ $V_{IL} = GND$ $I_O = 40mA$ $R_{EXT} = 470\Omega$ $V_{IH} = V_{DD}$ $C_L = 13pF$ $V_L = 3V$ $R_L = 65\Omega$		180	280	ns	
t_{PLH2}	Propagation delay time, $\overline{LE}/DM1-\overline{OUTn}$, $\overline{OE}/DM2 = L$			150	280	ns	
t_{PLH3}	Propagation delay time, $\overline{OE}/DM2-\overline{OUTn}$, $\overline{LE}/DM1 = H$			140	280	ns	
t_{PLH}	Propagation delay time, CLK-SDO			25	35	ns	
t_{PHL1}	Propagation delay time, CLK- \overline{OUTn} , $\overline{LE}/DM1 = H$, $\overline{OE}/DM2 = L$			30	60	ns	
t_{PHL2}	Propagation delay time, $\overline{LE}/DM1-\overline{OUTn}$, $\overline{OE}/DM2 = L$			30	50	ns	
t_{PHL3}	Propagation delay time, $\overline{OE}/DM2-\overline{OUTn}$, $\overline{LE}/DM1 = H$			35	70	ns	
t_{PHL}	Propagation delay time, CLK-SDO			30	40	ns	
t_r	Output rise time				220		ns
t_f	Output fall time				20		ns

6 Equivalent circuit of inputs and outputs

Figure 3. $\overline{\text{OE}}$ terminal

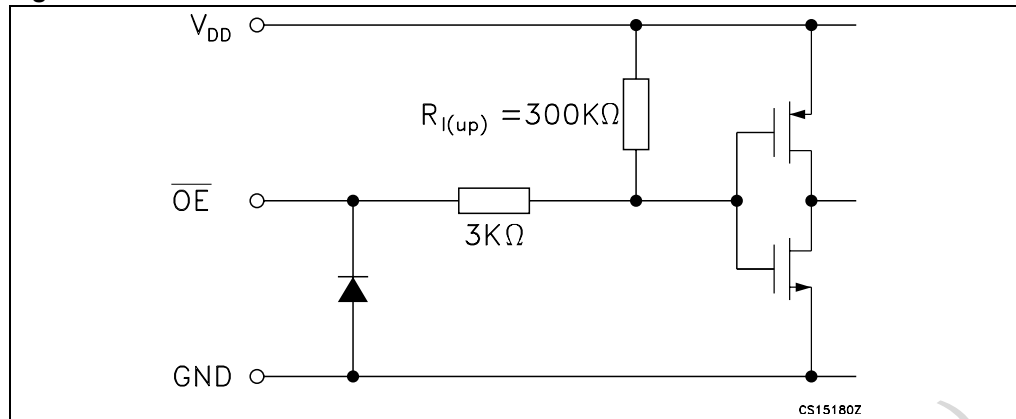

Figure 4. LE terminal

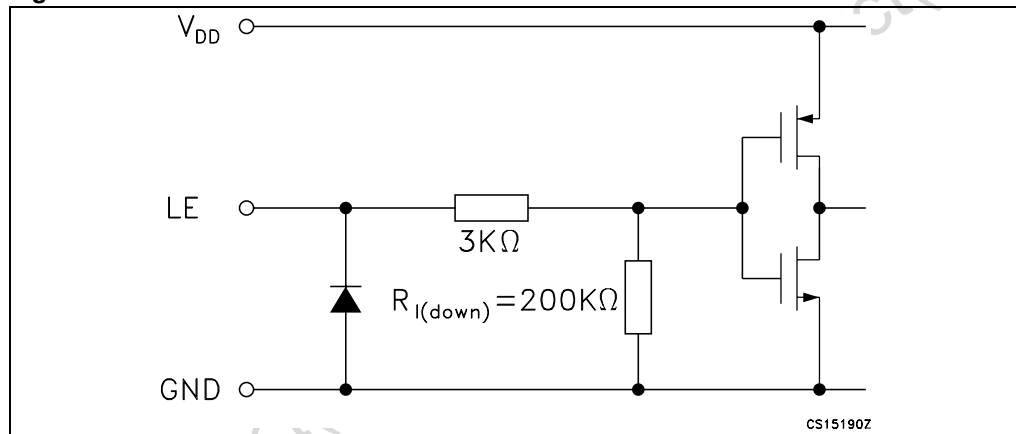

Figure 5. CLK, SDI terminal

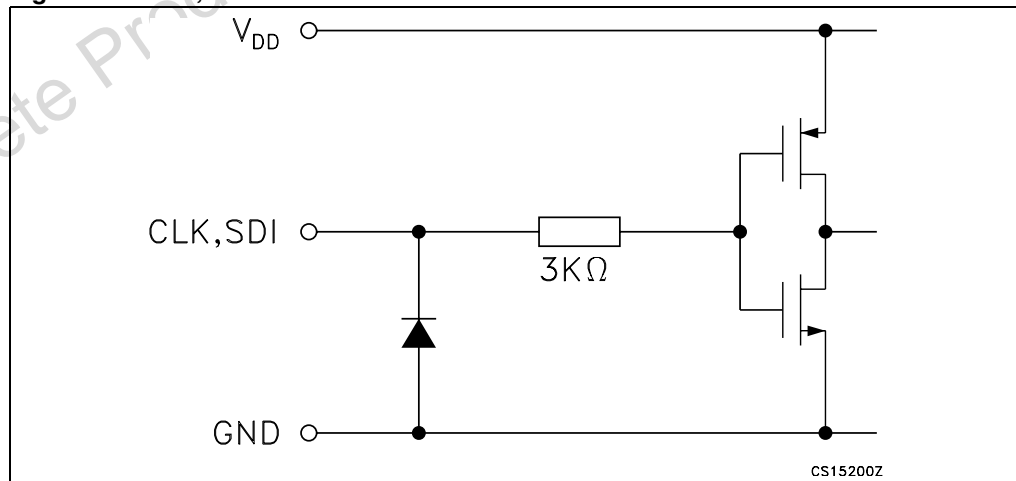
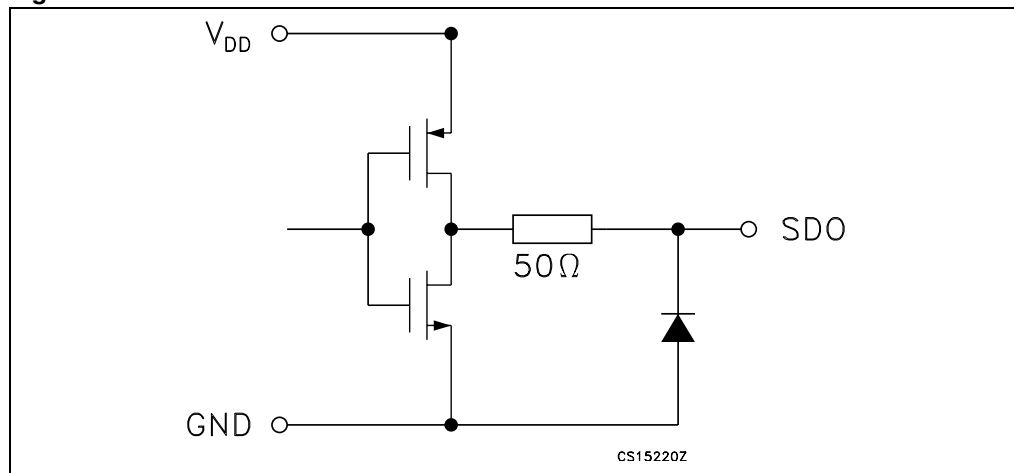
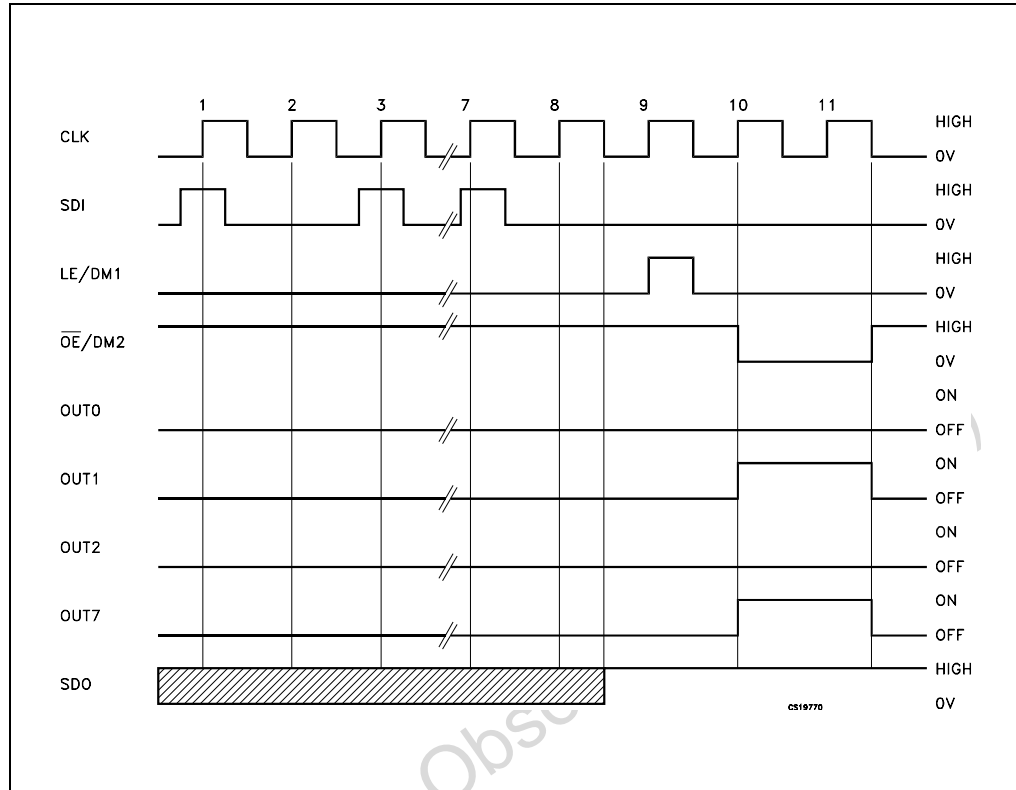

Figure 6. SDO terminal



7 Timing diagram

Figure 7. Timing diagram



Note: In normal mode the $\overline{OE}/DM2$ must remain low at least two clock cycles. In case of \overline{OE} signal enabled ($\overline{OE} = \text{LOW}$) during no clock activity (clock stopped), after the CLK restarts, 3 full CLK cycles are necessary before disabling the \overline{OE} signal ($\overline{OE} = \text{High}$).

Figure 8. Clock, serial-in, serial-out

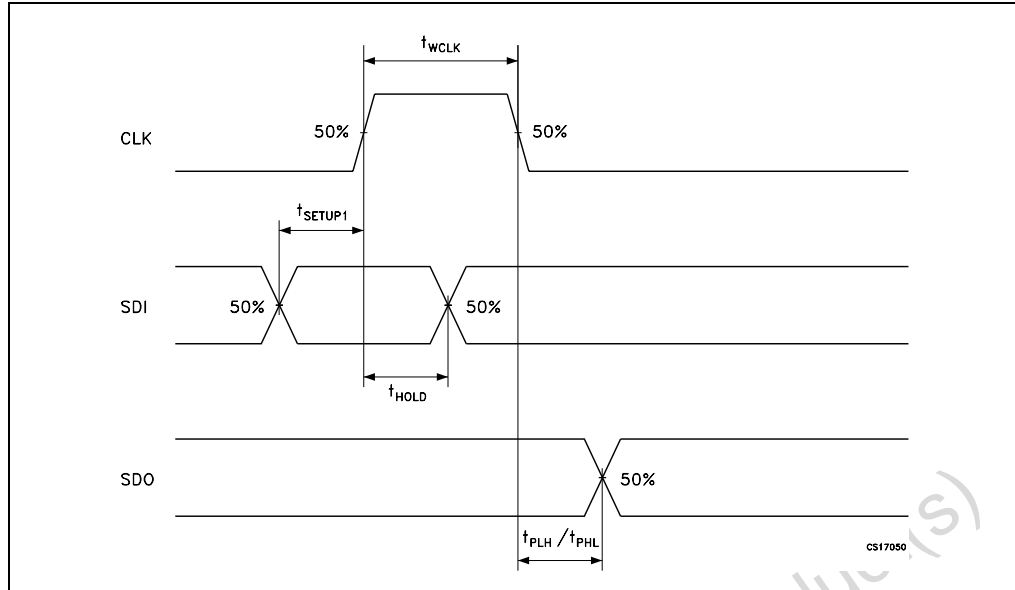

Figure 9. Clock, serial-in, latch, enable, outputs

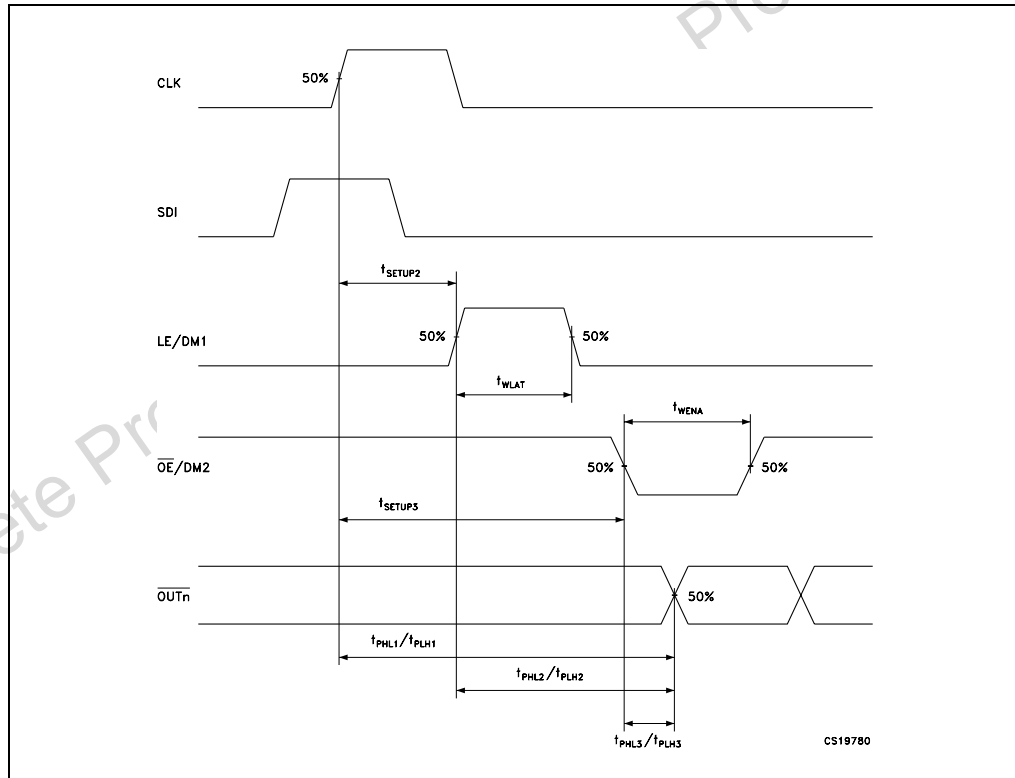
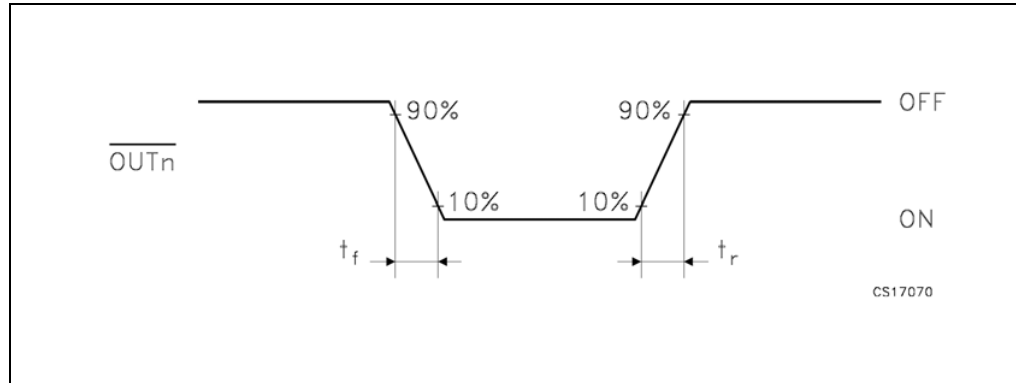

Figure 10. Outputs



Obsolete Product(s) - Obsolete Product(s)

8 Test circuit

Figure 11. DC characteristics

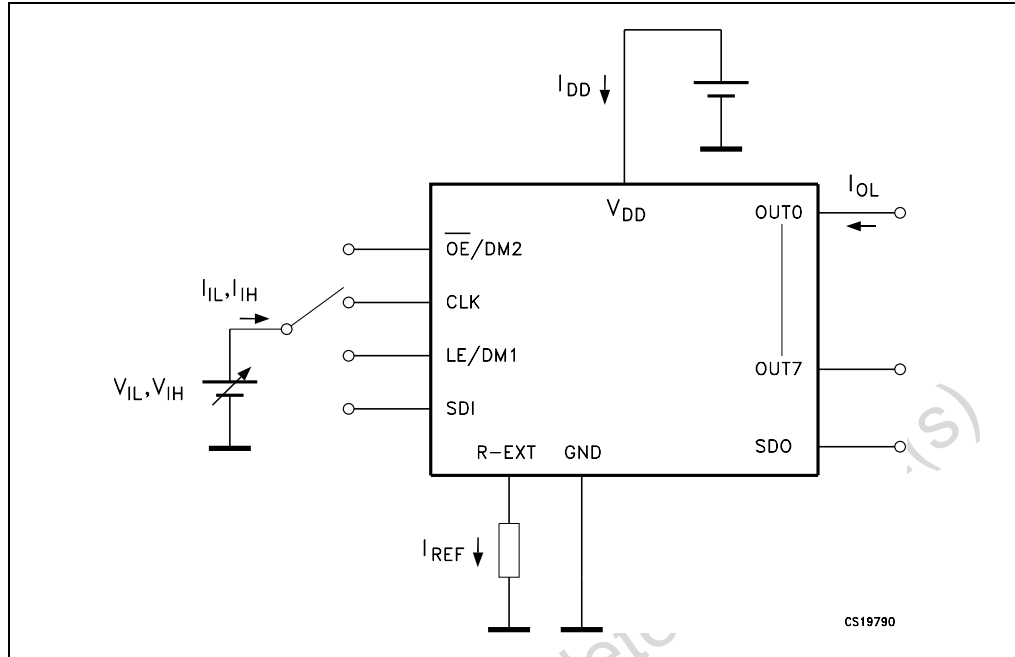

Figure 12. AC characteristics

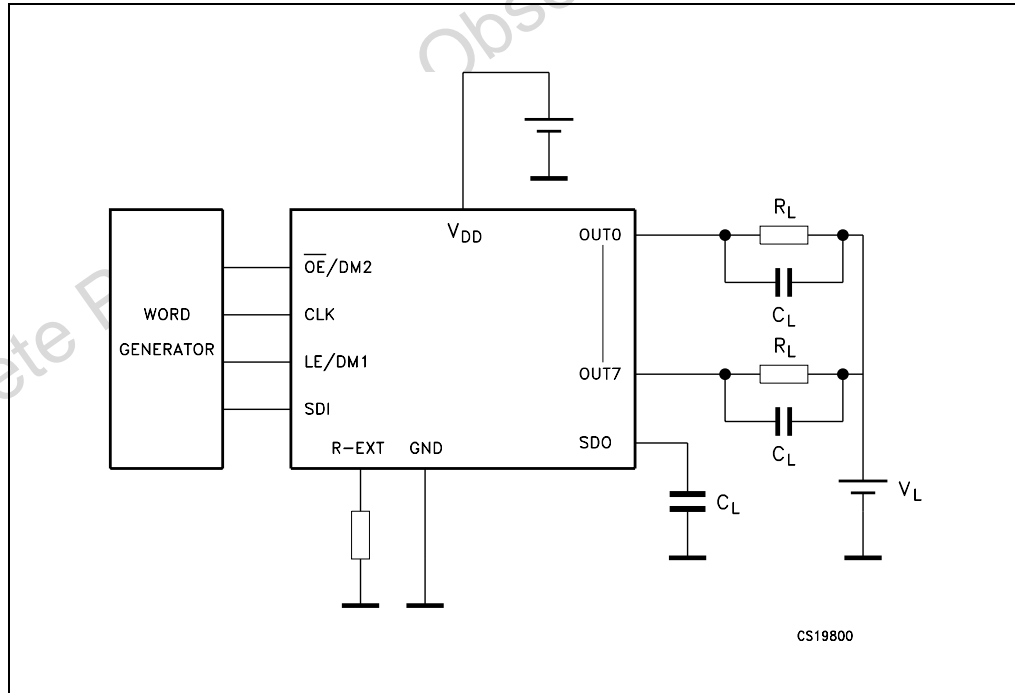
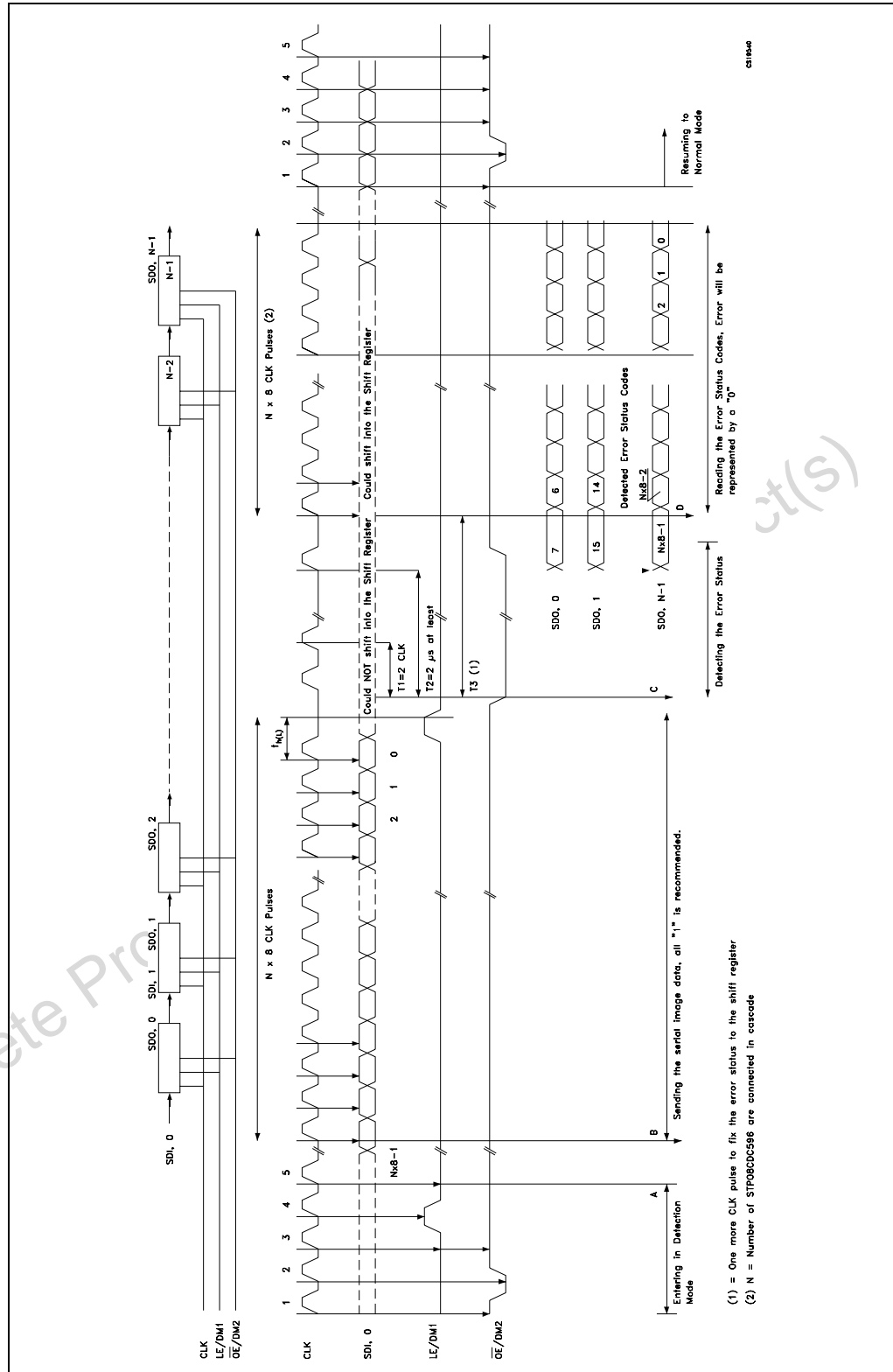

Figure 13. Timing example for open and/or short detection



9 Running the detection mode

9.1 Phase one: “entering in detection mode“

From the “Normal Mode” condition the device can switch to the “Error Mode” by a logic sequence on the OE/DM2 and LE/DM1 pins as showed in the following table and diagram:

Table 8. Entering in detection truth table

CLK	1°	2°	3°	4°	5°
OE/DM2	H	L	H	H	H
LE/DM1	L	L	L	H	L

Table 9. Entering in detection timing diagram

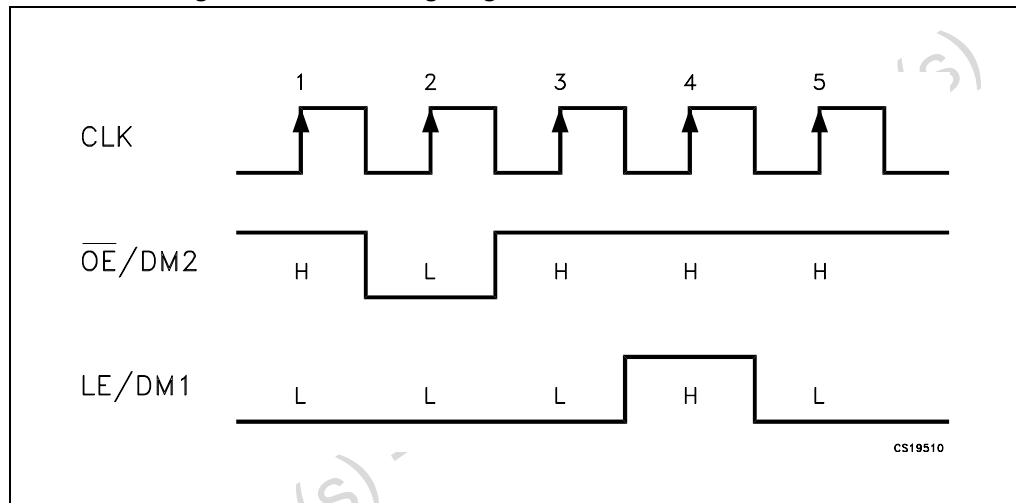

After these five CLK cycles the device goes into the “Error Detection Mode” and at the 6th rise front of CLK the SDI data are ready for the sampling.

9.2 Phase two: “error detection“

The eight data bits must be set “1“ in order to set ON all the outputs during the detection. The data are latched by LE/DM1 and after that the outputs are ready for the detection process. When the Micro controller switches the OE/DM2 to LOW, the device drives the LEDs in order to analyze if an OPEN or SHORT condition has occurred.

Table 10. Detection diagram

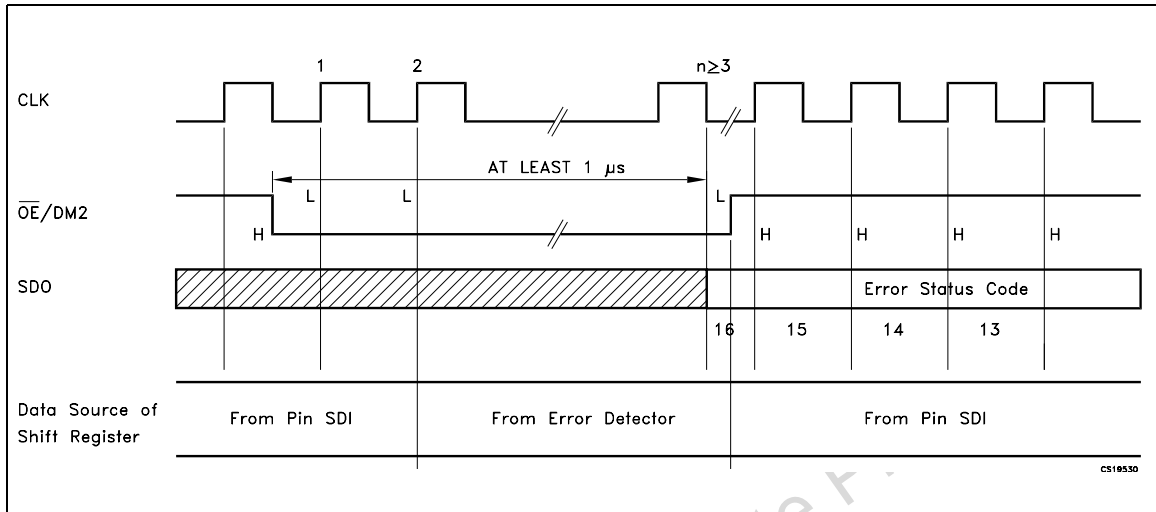

The LEDs status will be detected at least in 2 microseconds and after this time the microcontroller puts OE in HIGH state and the output data detection result will go to the microprocessor via SDO.

The detection data format is the same of data in normal mode. As soon as all the detection data bits are available on the serial line, the device may go back to normal mode operation.

9.3 Phase three: “resuming to normal mode”

The sequence for re-entering in normal mode is showed in the following Table and diagram:

Table 11. Resuming to normal mode timing diagram

CLK	1°	2°	3°	4°	5°
OE/DM2	H	L	H	H	H
LE/DM1	L	L	L	L	L

Table 12. Resuming to normal mode timing diagram

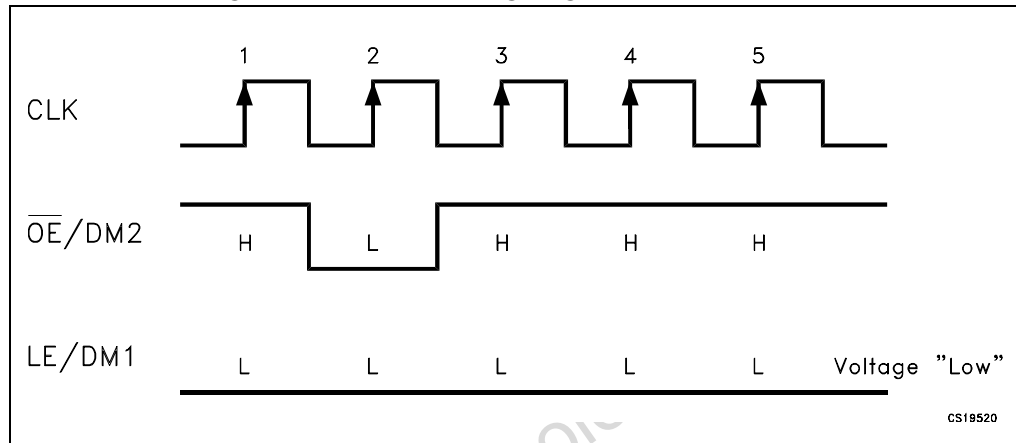

Note: For proper device operation the "Entering in detection" sequence must be follow by a "Resume Mode" sequence, isn't possible to insert consecutive equal sequence.

9.4 Condition in order to get a successfully detection condition

Table 13. Detection condition ($V_{DD} = 3.3$ to 5 V Temp. Range -40 to 85°C)

SW-1 or SW-3b	Open line or output short to GND detected	$\Rightarrow I_{ODEC} \leq 0.5 \times I_O$	No error detected	$\Rightarrow I_{ODEC} \geq 0.5 \times I_O$
SW-2 or SW-3a	Short on LED or short to V-LED detected	$\Rightarrow V_O \geq 2.4$ V	No error detected	$\Rightarrow V_O \leq 2.2$ V

Note: Where: I_O = the output current programmed by the R_{EXT} , I_{ODEC} = the detected output current in detection mode.

Figure 14. Detection circuit

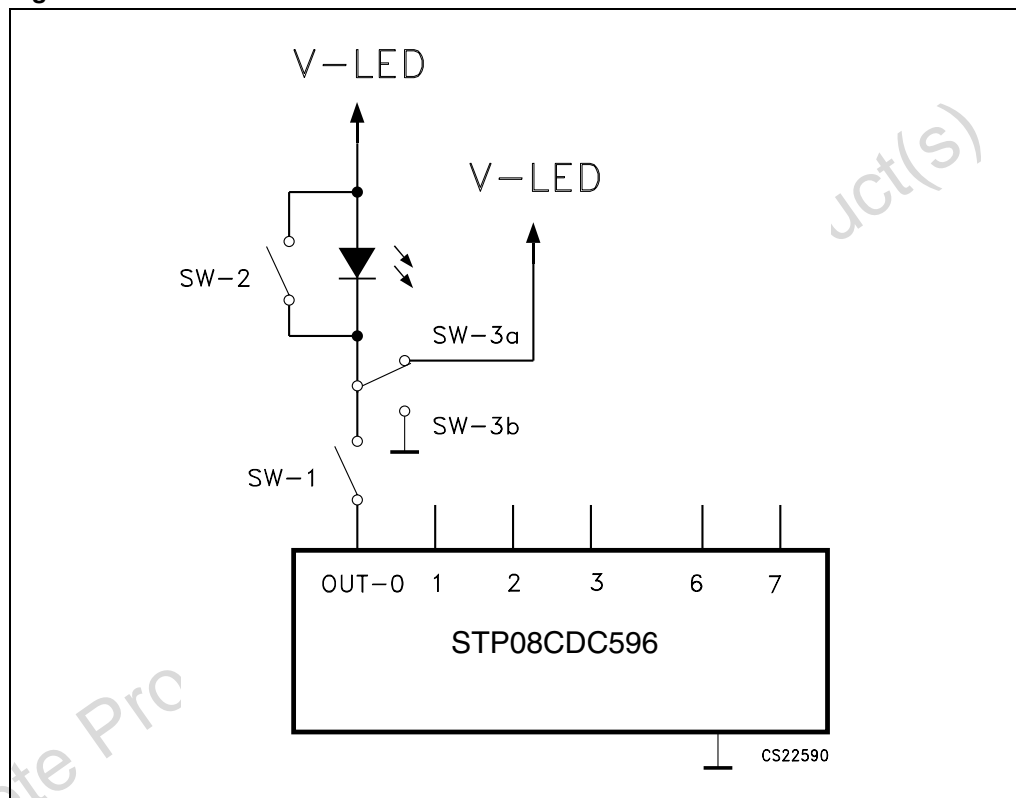

10 Typical characteristics

Figure 15. Output current-REXT resistor **Figure 16. Dropout voltage vs output current**

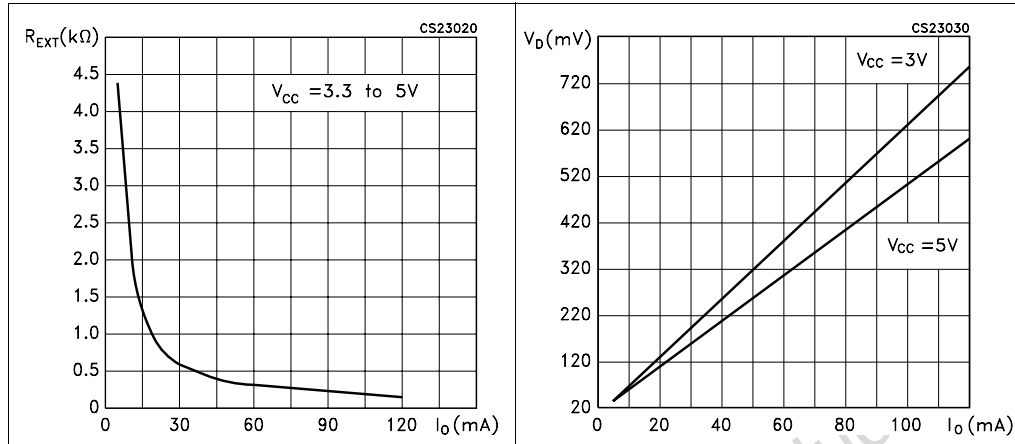
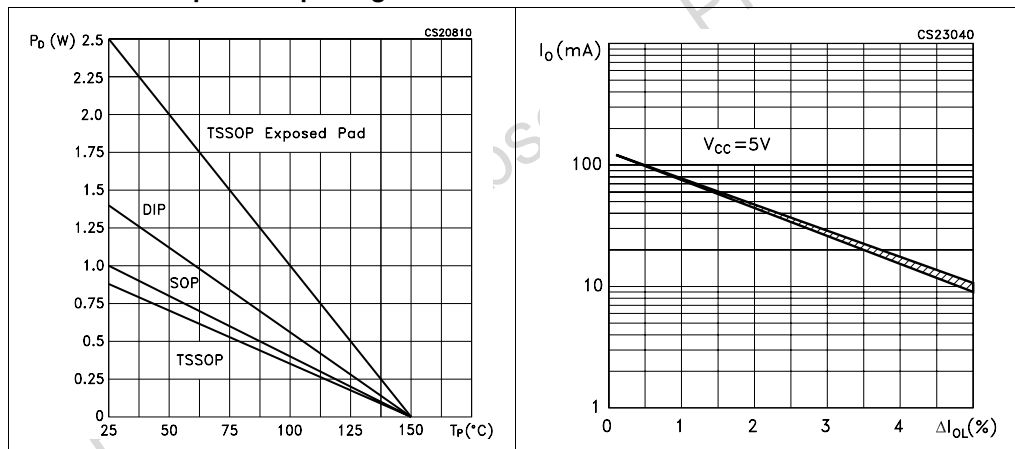

Figure 17. Power dissipation vs temperature package **Figure 18. Output current vs $\pm\Delta I_{OL}$ (%)**



11 Package mechanical data

In order to meet environmental requirements, ST offers these devices in ECOPACK® packages. These packages have a Lead-free second level interconnect. The category of second Level Interconnect is marked on the package and on the inner box label, in compliance with JEDEC Standard JESD97. The maximum ratings related to soldering conditions are also marked on the inner box label. ECOPACK is an ST trademark. ECOPACK specifications are available at: www.st.com.

Obsolete Product(s) - Obsolete Product(s)

Plastic DIP-16 (0.25) MECHANICAL DATA

DIM.	mm.			inch		
	MIN.	TYP	MAX.	MIN.	TYP.	MAX.
a1	0.51			0.020		
B	0.77		1.65	0.030		0.065
b		0.5			0.020	
b1		0.25			0.010	
D			20			0.787
E		8.5			0.335	
e		2.54			0.100	
e3		17.78			0.700	
F			7.1			0.280
I			5.1			0.201
L		3.3			0.130	
Z			1.27			0.050

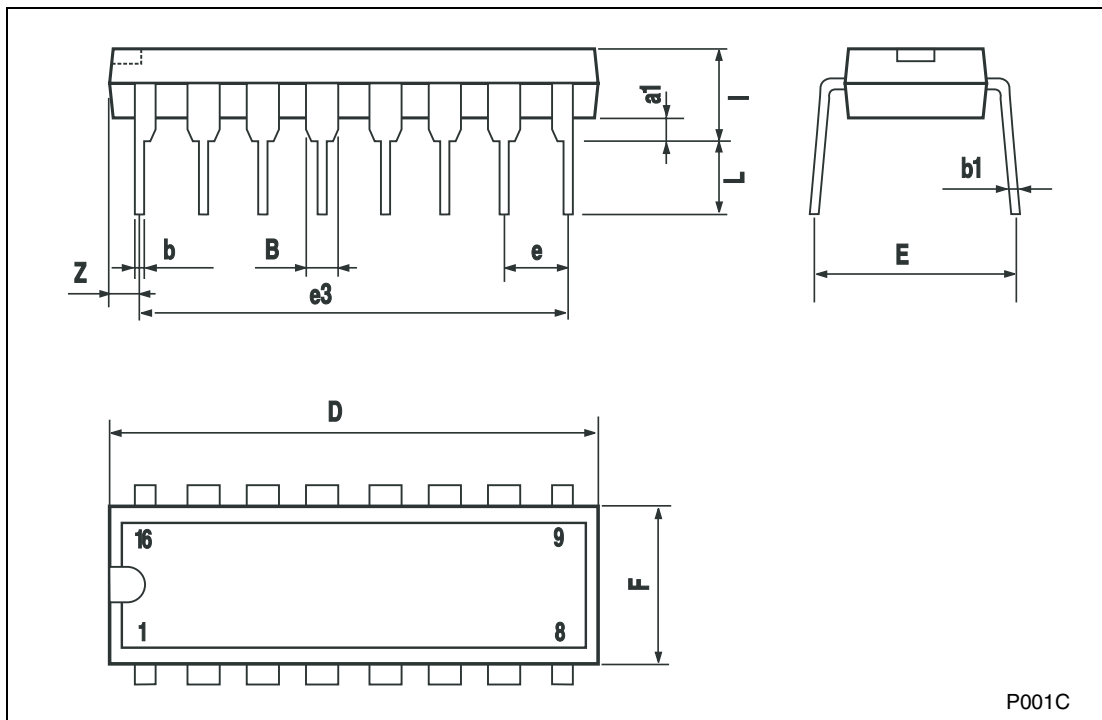

P001C

SO-16 MECHANICAL DATA

DIM.	mm.			inch		
	MIN.	TYP	MAX.	MIN.	TYP.	MAX.
A			1.75			0.068
a1	0.1		0.25	0.004		0.010
a2			1.64			0.063
b	0.35		0.46	0.013		0.018
b1	0.19		0.25	0.007		0.010
C		0.5			0.019	
c1	45° (typ.)					
D	9.8		10	0.385		0.393
E	5.8		6.2	0.228		0.244
e		1.27			0.050	
e3		8.89			0.350	
F	3.8		4.0	0.149		0.157
G	4.6		5.3	0.181		0.208
L	0.5		1.27	0.019		0.050
M			0.62			0.024
S	8° (max.)					

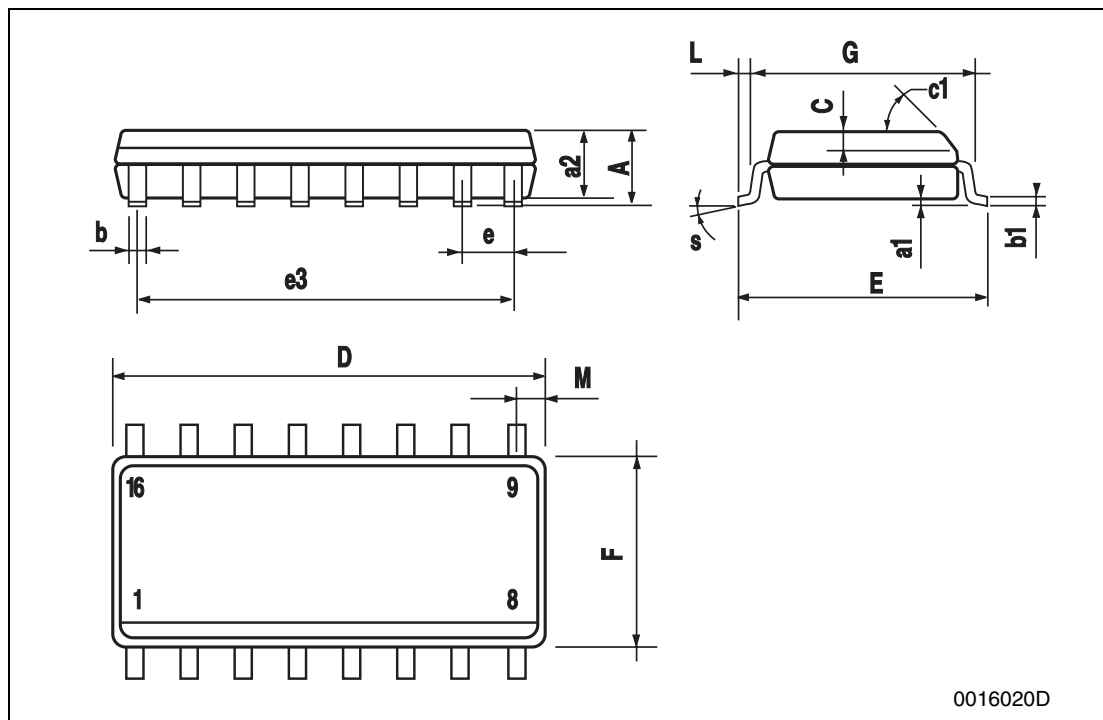

TSSOP16 MECHANICAL DATA

DIM.	mm.			inch		
	MIN.	TYP	MAX.	MIN.	TYP.	MAX.
A			1.2			0.047
A1	0.05		0.15	0.002	0.004	0.006
A2	0.8	1	1.05	0.031	0.039	0.041
b	0.19		0.30	0.007		0.012
c	0.09		0.20	0.004		0.0079
D	4.9	5	5.1	0.193	0.197	0.201
E	6.2	6.4	6.6	0.244	0.252	0.260
E1	4.3	4.4	4.48	0.169	0.173	0.176
e		0.65 BSC			0.0256 BSC	
K	0°		8°	0°		8°
L	0.45	0.60	0.75	0.018	0.024	0.030

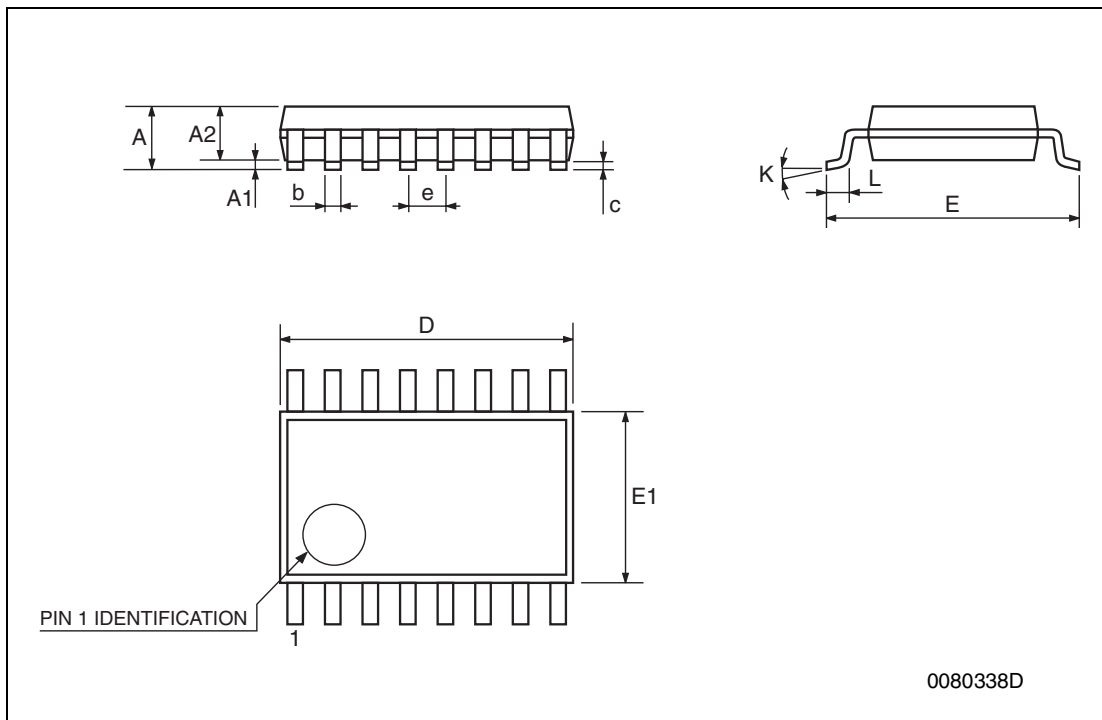

TSSOP16 EXPOSED PAD MECHANICAL DATA

DIM.	mm.			inch		
	MIN.	TYP	MAX.	MIN.	TYP.	MAX.
A			1.2			0.047
A1			0.15		0.004	0.006
A2	0.8	1	1.05	0.031	0.039	0.041
b	0.19		0.30	0.007		0.012
c	0.09		0.20	0.004		0.0089
D	4.9	5	5.1	0.193	0.197	0.201
D1	1.7			0.067		
E	6.2	6.4	6.6	0.244	0.252	0.260
E1	4.3	4.4	4.5	0.169	0.173	0.177
E2	1.5			0.059		
e		0.65			0.0256	
K	0°		8°	0°		8°
L	0.45	0.60	0.75	0.018	0.024	0.030

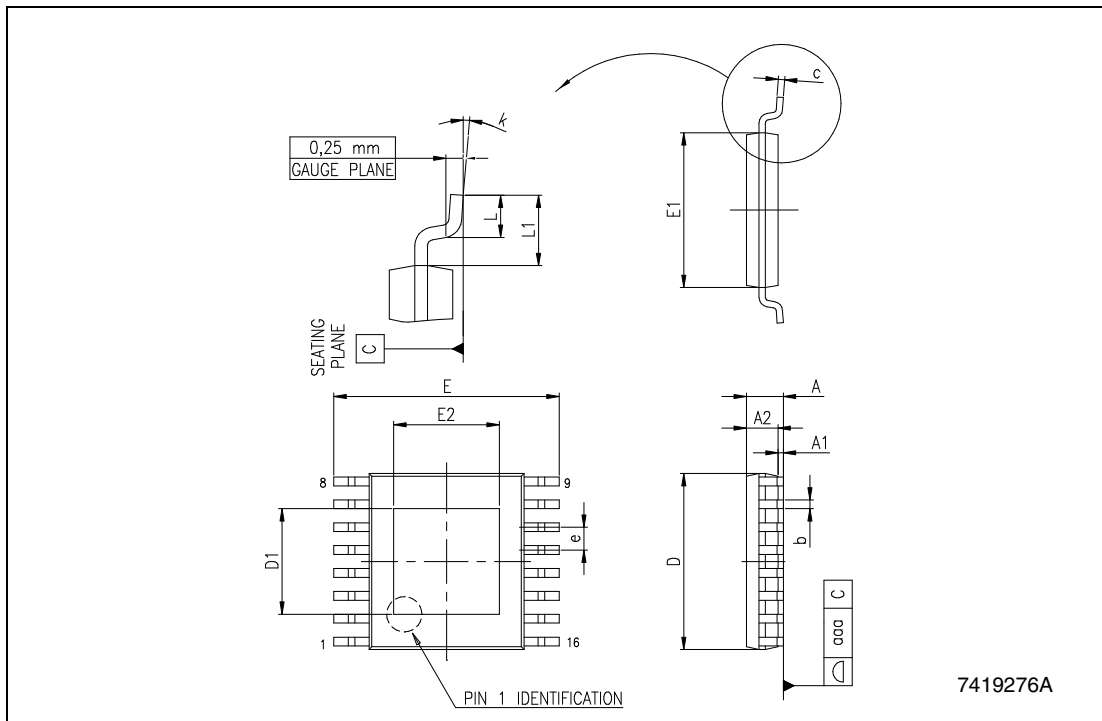

Tape & Reel TSSOP16 MECHANICAL DATA

DIM.	mm.			inch		
	MIN.	TYP	MAX.	MIN.	TYP.	MAX.
A			330			12.992
C	12.8		13.2	0.504		0.519
D	20.2			0.795		
N	60			2.362		
T			22.4			0.882
Ao	6.7		6.9	0.264		0.272
Bo	5.3		5.5	0.209		0.217
Ko	1.6		1.8	0.063		0.071
Po	3.9		4.1	0.153		0.161
P	7.9		8.1	0.311		0.319

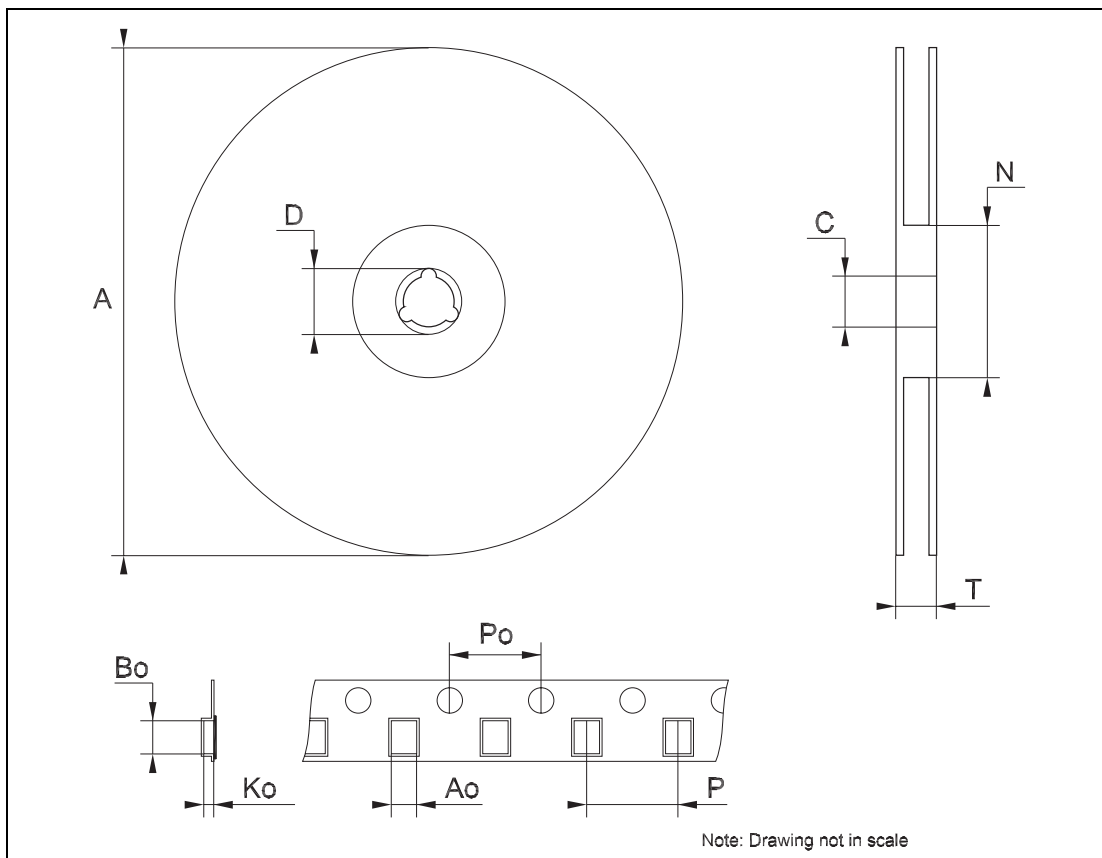

Tape & Reel SO-16 MECHANICAL DATA

DIM.	mm.			inch		
	MIN.	TYP	MAX.	MIN.	TYP.	MAX.
A			330			12.992
C	12.8		13.2	0.504		0.519
D	20.2			0.795		
N	60			2.362		
T			22.4			0.882
Ao	6.45		6.65	0.254		0.262
Bo	10.3		10.5	0.406		0.414
Ko	2.1		2.3	0.082		0.090
Po	3.9		4.1	0.153		0.161
P	7.9		8.1	0.311		0.319

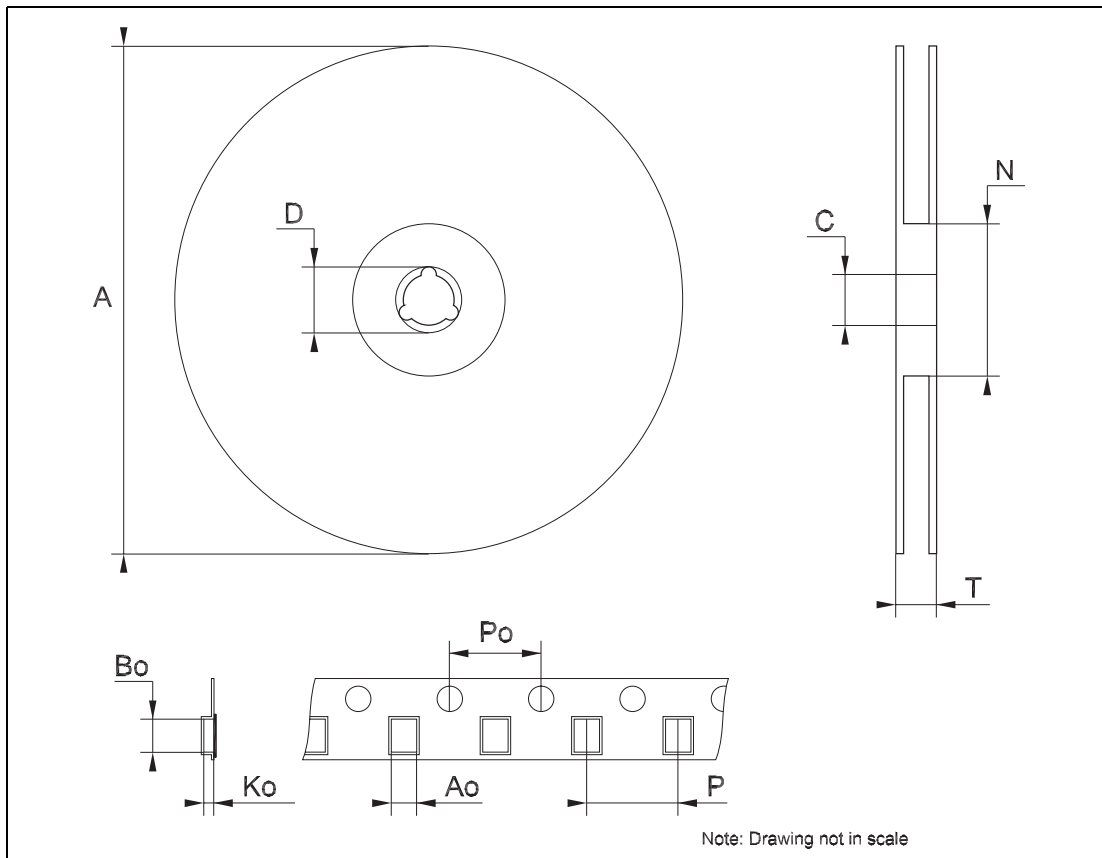

12 Revision history

Table 1. Revision history

Date	Revision	Changes
15-Jun-2005	1	First release
11-Oct-2005	2	Minor revision, no content change
2-Aug-2006	3	New template, block diagram <i>Figure 2 on page 4</i> and equivalent circuit <i>Section 6 on page 9</i> updated, added TSSOP-16 Exposed Pad package.

Obsolete Product(s) - Obsolete Product(s)

Please Read Carefully:

Information in this document is provided solely in connection with ST products. STMicroelectronics NV and its subsidiaries ("ST") reserve the right to make changes, corrections, modifications or improvements, to this document, and the products and services described herein at any time, without notice.

All ST products are sold pursuant to ST's terms and conditions of sale.

Purchasers are solely responsible for the choice, selection and use of the ST products and services described herein, and ST assumes no liability whatsoever relating to the choice, selection or use of the ST products and services described herein.

No license, express or implied, by estoppel or otherwise, to any intellectual property rights is granted under this document. If any part of this document refers to any third party products or services it shall not be deemed a license grant by ST for the use of such third party products or services, or any intellectual property contained therein or considered as a warranty covering the use in any manner whatsoever of such third party products or services or any intellectual property contained therein.

UNLESS OTHERWISE SET FORTH IN ST'S TERMS AND CONDITIONS OF SALE ST DISCLAIMS ANY EXPRESS OR IMPLIED WARRANTY WITH RESPECT TO THE USE AND/OR SALE OF ST PRODUCTS INCLUDING WITHOUT LIMITATION IMPLIED WARRANTIES OF MERCHANTABILITY, FITNESS FOR A PARTICULAR PURPOSE (AND THEIR EQUIVALENTS UNDER THE LAWS OF ANY JURISDICTION), OR INFRINGEMENT OF ANY PATENT, COPYRIGHT OR OTHER INTELLECTUAL PROPERTY RIGHT.

UNLESS EXPRESSLY APPROVED IN WRITING BY AN AUTHORIZED ST REPRESENTATIVE, ST PRODUCTS ARE NOT RECOMMENDED, AUTHORIZED OR WARRANTED FOR USE IN MILITARY, AIR CRAFT, SPACE, LIFE SAVING, OR LIFE SUSTAINING APPLICATIONS, NOR IN PRODUCTS OR SYSTEMS WHERE FAILURE OR MALFUNCTION MAY RESULT IN PERSONAL INJURY, DEATH, OR SEVERE PROPERTY OR ENVIRONMENTAL DAMAGE. ST PRODUCTS WHICH ARE NOT SPECIFIED AS "AUTOMOTIVE GRADE" MAY ONLY BE USED IN AUTOMOTIVE APPLICATIONS AT USER'S OWN RISK.

Resale of ST products with provisions different from the statements and/or technical features set forth in this document shall immediately void any warranty granted by ST for the ST product or service described herein and shall not create or extend in any manner whatsoever, any liability of ST.

ST and the ST logo are trademarks or registered trademarks of ST in various countries.

Information in this document supersedes and replaces all information previously supplied.

The ST logo is a registered trademark of STMicroelectronics. All other names are the property of their respective owners.



© 2006 STMicroelectronics - All rights reserved

STMicroelectronics group of companies

Australia - Belgium - Brazil - Canada - China - Czech Republic - Finland - France - Germany - Hong Kong - India - Israel - Italy - Japan - Malaysia - Malta - Morocco - Singapore - Spain - Sweden - Switzerland - United Kingdom - United States of America

www.st.com

