

### Features

- Adjustable constant output current
- Wide input voltage range
- Low drop voltage
- Open load detection
- Overtemperature protection
- Short circuit proof
- Reverse polarity proof
- Wide temperature range:  $-40\text{ °C} < T_j < 150\text{ °C}$
- Very small SMD-Package

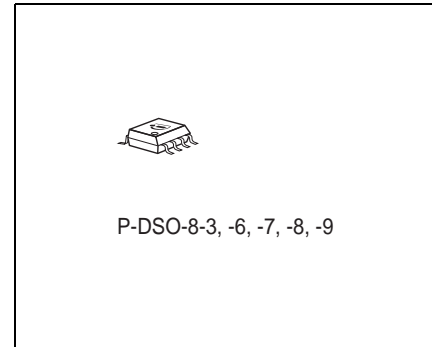

### Functional Description

The **TLE 4241 GM** is an integrated adjustable constant current source. It provides an output current adjustable via different means (SET, PWM, reference resistor) which is kept nearly independent from load and supply voltage changes. The IC is designed to supply LEDs under the severe conditions of automotive applications resulting in constant brightness and extended LED lifetime. It is provided in the very small P-DSO-8-9 (Micro 8) package. Protection circuits prevent damage to the device in case of overload, short circuit, reverse polarity and overtemperature. The connected LEDs are protected against reverse polarity as well as excess voltages up to 45 V. A status output allows handling of open load and short circuit at the main output.

A PWM input offers the possibility to adjust the LED brightness by pulse width modulation.

With an implemented high/low current switch the output current level can be reduced e.g. for brake/tail light application.

The implemented features such as adjustable output current, the high/low current switch and the provided PWM input make the device well suited for a broad range of LED and other applications.

Type	Ordering Code	Package
TLE 4241 GM	Q67006-A9644	P-DSO-8-9

### Circuit Description

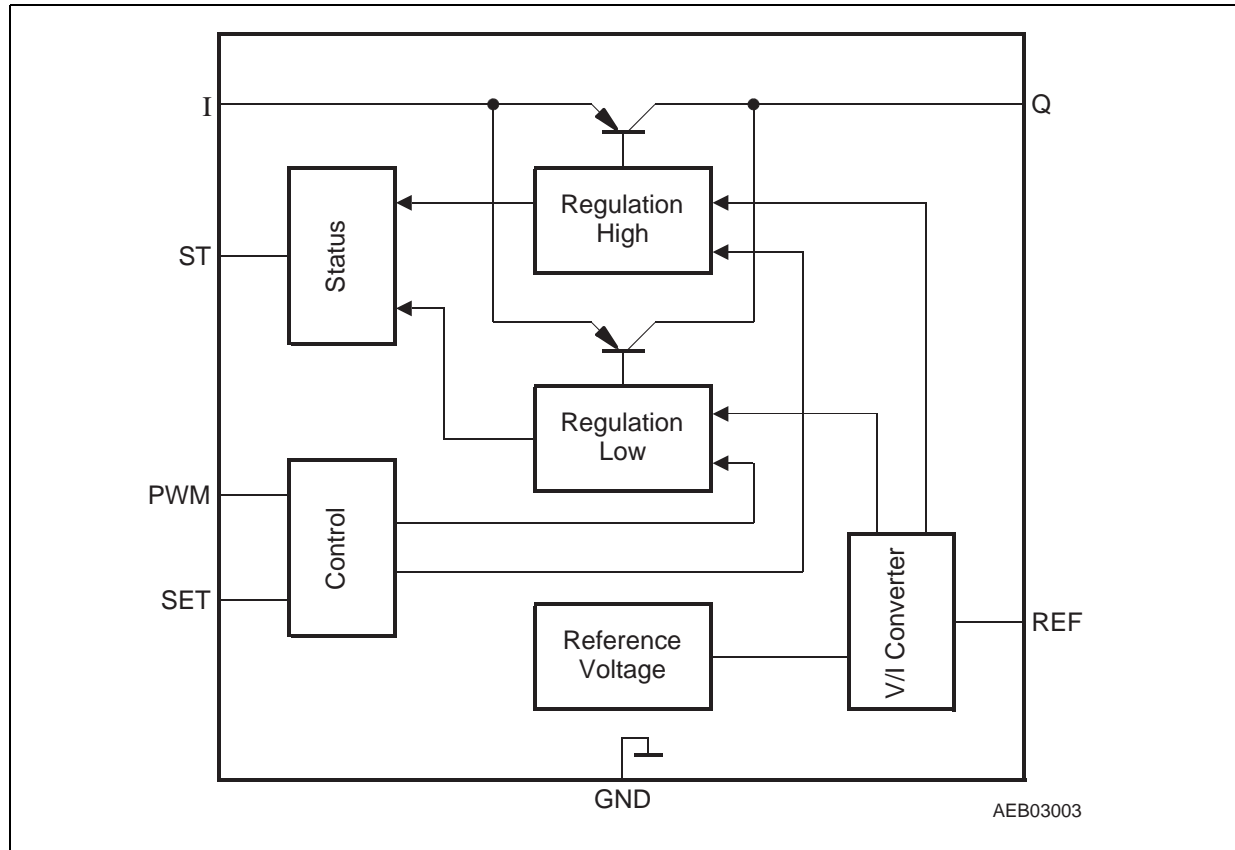

**Figure 1 Block Diagram**

An internal reference voltage of typ. 1.20 V supplies the REF pin which is connected to GND via an external resistor. In the SET = H mode the reference current flowing on the REF pin is mirrored with an amplification to form the desired output current. The typ. output current in the SET = H mode calculates:

$$I_{Q, \text{typ}}/\text{mA} = \frac{1.20}{R_{\text{REF}}/\text{k}\Omega} \times 487 + 0.1 \quad (1)$$

The output current is shown as a function of the reference resistance on [Page 10](#) for the high as well as for the low current mode.

With the PWM input the LED brightness can be regulated via duty cycle. Also PWM = L sets the TLE 4241 in sleep mode resulting in a very low current consumption of  $\ll 1 \mu\text{A}$  typ. Due to the high impedance of the PWM input (see timing diagram  $I_{\text{PWM}}$  versus  $V_{\text{PWM}}$  on [Page 12](#)) the PWM pin can thus also be used as an Enable input.

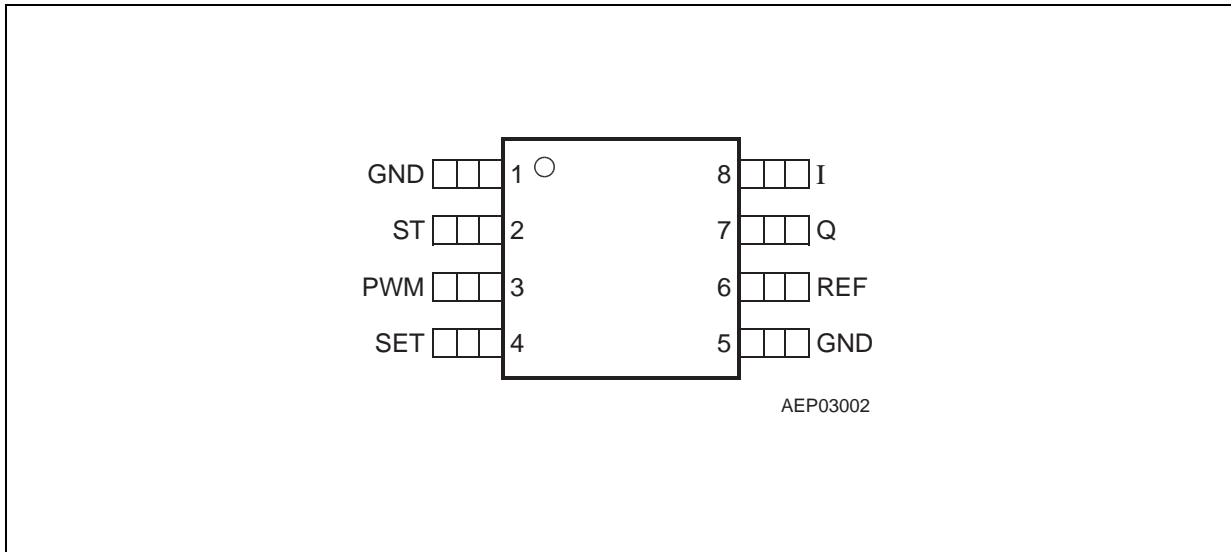
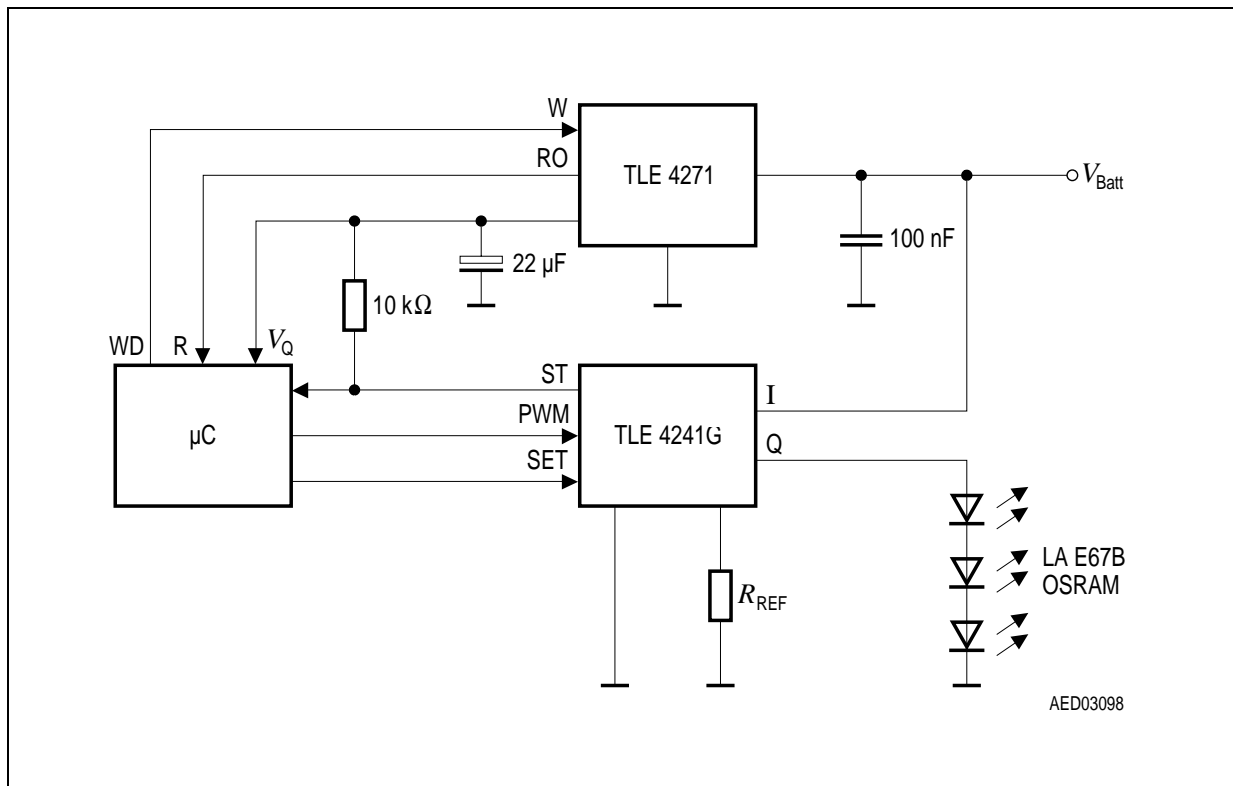

**Figure 2 Pin Configuration (top view)**

**Table 1 Pin Definitions and Functions**

Pin No.	Symbol	Function
1	GND	<b>Ground</b> ; internally connected to pin 5
2	ST	<b>Status Output</b> ; open collector output, connect to external pull-up resistor (10 kΩ or higher)
3	PWM	<b>Pulse Width Modulation Input</b> ; if not needed connect to $V_I$
4	SET	<b>High/Low Current Input</b> ; choice of current level
5	GND	<b>Ground</b> ; internally connected to pin 1
6	REF	<b>Reference Input</b> ; connect to GND via an external resistor to adjust the output current
7	Q	<b>Output</b>
8	I	<b>Input</b> ; block to GND directly at the IC with a 100 nF ceramic capacitor

## Application Information



**Figure 3 Application Circuit**

**Figure 3** shows a typical application with the TLE 4241 GM LED driver. The 3 LEDs are driven with an adequate supply current adjusted by the resistor  $R_{REF}$ . Thus brightness variations due to forward voltage spread of the LEDs are prevented. The luminosity spread arising from the LED production process can be compensated via software by an appropriate duty cycle applied to the PWM pin. Hence selection of the LEDs to forward voltage as well as to luminosity classes can be spared. The slightly negative temperature coefficient of the TLE 4241 GM output current protects the LEDs against over-temperature stress if the IC is placed nearby the LEDs.

The voltage drop ( $V_I - V_Q$ ) across the TLE 4241 GM is monitored in order to detect an open load condition indicated at the status output pin ST. In case of open load, the voltage drop will decrease below the lower status switching threshold  $V_{dr,L}$ . Hence, the status output ST will be driven low. In normal operation, the voltage drop is above the upper status threshold  $V_{dr,H}$ , thus the open collector output ST is in high-ohmic state (see also section Status Output at the Electrical Characteristics).

The function of ST, SET and PWM as well as their timings are shown in **Figure 4**.

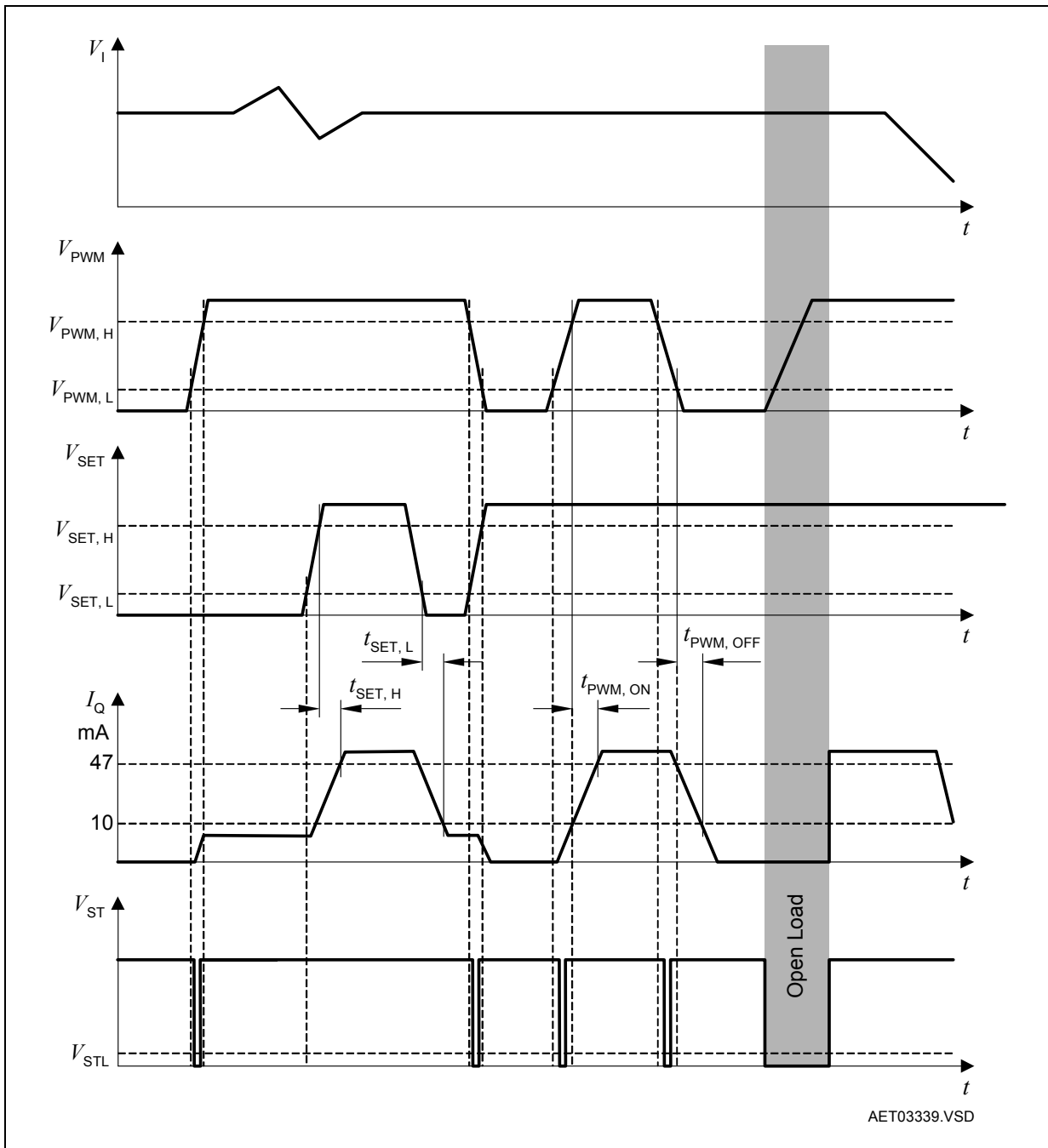

Figure 4 Function and Timing Diagram

**Table 2 Absolute Maximum Ratings**
 $-40\text{ °C} < T_j < 150\text{ °C}$ 

Parameter	Symbol	Limit Values		Unit	Remarks
		Min.	Max.		
<b>Input</b>					
Voltage	$V_I$	-42	45	V	–
Current	$I_I$	–	–	mA	internally limited
<b>Output</b>					
Voltage	$V_Q$	-1	40	V	–
Current	$I_Q$	–	–	mA	internally limited
<b>Status Output</b>					
Voltage	$V_{ST}$	-0.3	40	V	–
Current	$I_{ST}$	– 5	5	mA	internally limited
<b>Reference Input</b>					
Voltage	$V_{REF}$	-0.3	7	V	–
Current	$I_{REF}$	-2	2	mA	–
<b>Pulse Width Modulation Input</b>					
Voltage	$V_{PWM}$	-40	40	V	–
Current	–	-1	1	mA	–
<b>High/Low Current Input</b>					
Voltage	$V_{SET}$	-40	40	V	–
Current	$I_{SET}$	-1	1	mA	–
<b>Temperatures</b>					
Junction temperature	$T_j$	-40	150	°C	–
Storage temperature	$T_{stg}$	-50	150	°C	–
<b>Thermal Resistances</b>					
Junction ambient	$R_{thja}$	–	105	K/W	1)

1) Worst case regarding peak temperature; mounted on PCB  $80 \times 80 \times 1.5\text{ mm}^3$ ,  $35\text{ }\mu\text{m}$  Cu,  $300\text{ mm}^2$  heat sink area.

*Note: Maximum ratings are absolute ratings; exceeding any one of these values may cause irreversible damage to the integrated circuit.*

**Table 3      Operating Range**

Parameter	Symbol	Limit Values		Unit	Remarks
		Min.	Max.		
Input voltage	$V_I$	4	45	V	–
Status output voltage	$V_{ST}$	–	16	V	–
SET voltage	$V_{SET}$	0	40	V	–
PWM voltage	$V_{PWM}$	0	40	V	–
Junction temperature	$T_j$	-40	150	°C	–
Reference Resistor	$R_{REF}$	7	100	kΩ	SET = H
		4.7	18	kΩ	SET = L

**Table 4 Electrical Characteristics**

9 V ≤ V<sub>I</sub> ≤ 16 V; R<sub>REF</sub> = 10 kΩ; V<sub>PWM</sub> ≥ V<sub>PWM,H</sub>; -40 °C < T<sub>j</sub> < 150 °C; all voltages with respect to ground; positive current defined flowing into pin; unless otherwise specified

Parameter	Symbol	Limit Values			Unit	Test Condition
		Min.	Typ.	Max.		
Current consumption off mode	I <sub>qOFF</sub>	–	0.1	2	μA	PWM = L, T <sub>j</sub> < 85 °C; V <sub>I</sub> ≤ 13.5 V
Current consumption	I <sub>qL</sub>	–	5	10	mA	SET = L; V <sub>Q</sub> = 6 V
Current consumption	I <sub>qH</sub>	–	6	10	mA	SET = H; V <sub>Q</sub> = 6 V
Current consumption open load	I <sub>qL,O</sub>	–	–	10	mA	SET = L; V <sub>Q</sub> open
Current consumption open load	I <sub>qH,O</sub>	–	–	10	mA	SET = H; V <sub>Q</sub> open

**Output**

Output current	I <sub>Q</sub>	6.7	8.4	10	mA	SET = L, V <sub>Q</sub> = 6 V
		–	8.6	–	mA	SET = L, V <sub>Q</sub> = 4 V
Output current	I <sub>Q</sub>	47	58.5	70	mA	SET = H, V <sub>Q</sub> = 6 V
		–	60.0	–	mA	SET = H, V <sub>Q</sub> = 4 V
Current Ratio	I <sub>qH</sub> /I <sub>qL</sub>	6	7	8	–	–
Output current limit	I <sub>Qmax</sub>	–	83	–	mA	SET = L; R <sub>REF</sub> = 0 Ω
Output current limit	I <sub>Qmax</sub>	–	83	–	mA	SET = H; R <sub>REF</sub> = 0 Ω
Drop voltage	V <sub>dr</sub>	–	0.2	0.5	V	SET = L; I <sub>Q</sub> = 80% of I <sub>Q,nom,L</sub>
Drop voltage	V <sub>dr</sub>	–	0.3	0.5	V	SET = H; I <sub>Q</sub> = 80% of I <sub>Q,nom,H</sub>

**PWM Input**

PWM high level	V <sub>PWM,H</sub>	2.0	–	–	V	–
PWM low level	V <sub>PWM,L</sub>	–	–	0.5	V	–
PWM input current high level	I <sub>PWM,H</sub>	–	220	500	μA	V <sub>PWM</sub> = 5.0 V
PWM input current low level	I <sub>PWM,L</sub>	-10	–	10	μA	V <sub>PWM</sub> = 0.0 V
Turn on delay time	t <sub>PWM,ON</sub>	0	5	30	μs	20%/80% I <sub>Q</sub> , see <a href="#">Figure 4</a>



**Table 4 Electrical Characteristics (cont'd)**

9 V ≤ V<sub>I</sub> ≤ 16 V; R<sub>REF</sub> = 10 kΩ; V<sub>PWM</sub> ≥ V<sub>PWM,H</sub>; -40 °C < T<sub>j</sub> < 150 °C; all voltages with respect to ground; positive current defined flowing into pin; unless otherwise specified

Parameter	Symbol	Limit Values			Unit	Test Condition
		Min.	Typ.	Max.		
Turn off delay time	t <sub>PWM,OFF</sub>	0	10	30	μs	20%/80% I <sub>Q</sub> , see <a href="#">Figure 4</a>
<b>SET Input</b>						
SET high level	V <sub>SET,H</sub>	2.0	–	–	V	–
SET low level	V <sub>SET,L</sub>	–	–	0.5	V	–
SET input current high level	I <sub>SET,H</sub>	–	220	500	μA	V <sub>SET</sub> = 5.0 V
SET input current low level	I <sub>SET,L</sub>	-10	–	10	μA	V <sub>SET</sub> = 0.0 V
Delay time L -> H	t <sub>SET,H</sub>	–	–	30	μs	20%/80% I <sub>Q</sub> , see <a href="#">Figure 4</a>
Delay time H -> L	t <sub>SET,L</sub>	–	–	30	μs	20%/80% I <sub>Q</sub> , see <a href="#">Figure 4</a>
<b>Status Output</b>						
Lower status switching threshold	V <sub>dr,L</sub>	0.15	–	–	V	(V <sub>I</sub> - V <sub>Q</sub> ) decreasing SET = L
		0.15	–	–	V	(V <sub>I</sub> - V <sub>Q</sub> ) decreasing SET = H
Upper status switching threshold	V <sub>dr,H</sub>	–	–	0.7	V	(V <sub>I</sub> - V <sub>Q</sub> ) increasing SET = L
		–	–	0.7	V	(V <sub>I</sub> - V <sub>Q</sub> ) increasing SET = H
Status low voltage	V <sub>STL</sub>	–	–	0.4	V	(V <sub>I</sub> - V <sub>Q</sub> ) < V <sub>dr,L</sub> I <sub>ST</sub> = 1.0 mA
Leakage current	I <sub>STLK</sub>	–	–	10	μA	(V <sub>I</sub> - V <sub>Q</sub> ) > V <sub>dr,H</sub> V <sub>ST</sub> = 5.0 V

**Typical Performance Characteristics**

**Output Current versus External Resistor, SET = H**

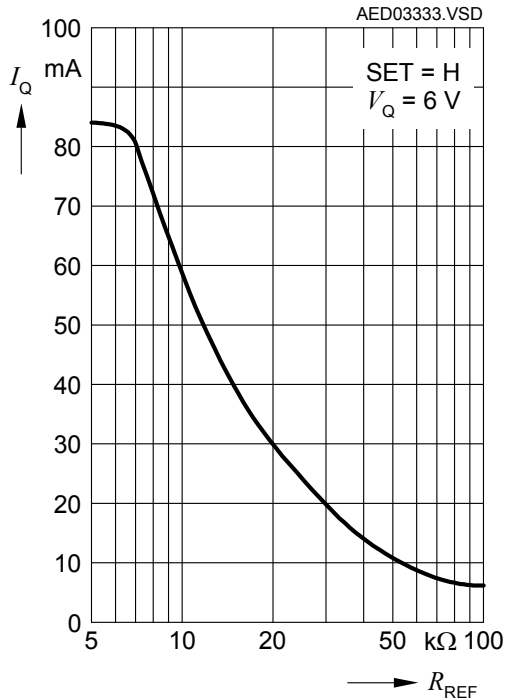

**Output Current versus External Resistor, SET = L**

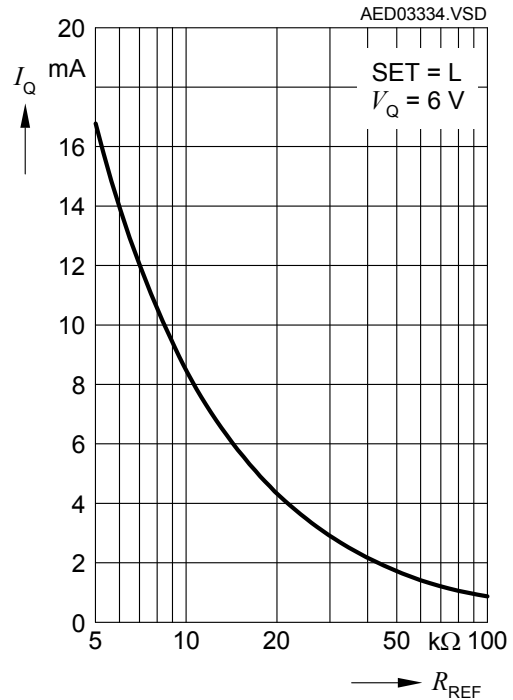

**Output Current versus Supply Voltage, SET = H**

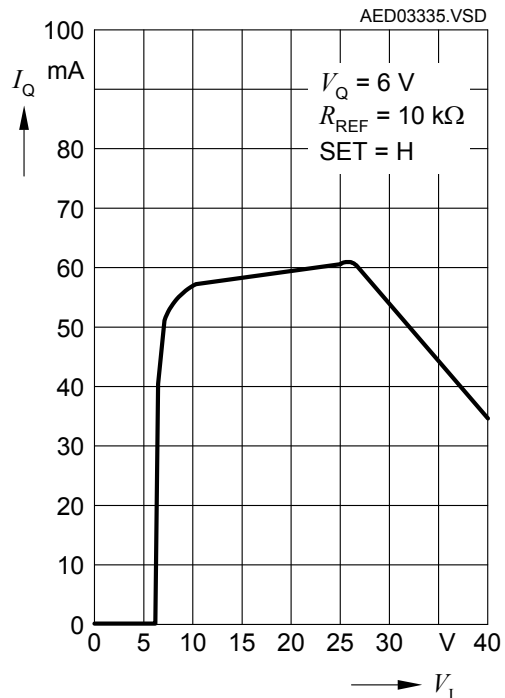

**Output Current versus Supply Voltage, SET = L**

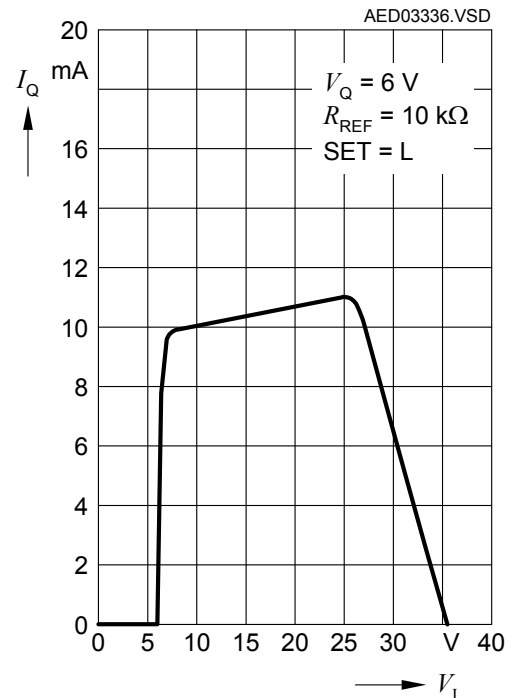

### Reference Voltage versus Junction Temperature

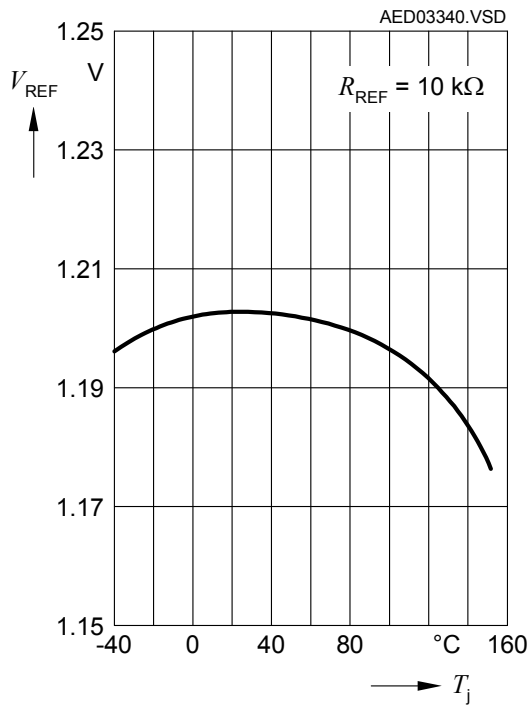

**PWM Pin Input Current versus PWM Voltage**

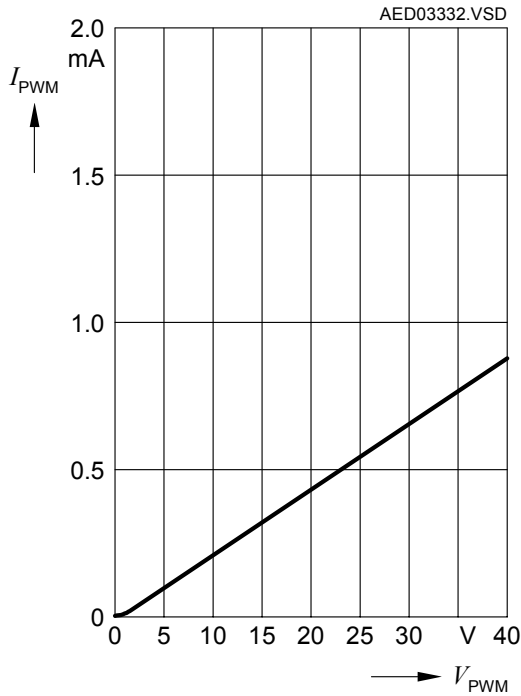

**PWM Pin Input Current versus PWM Voltage**

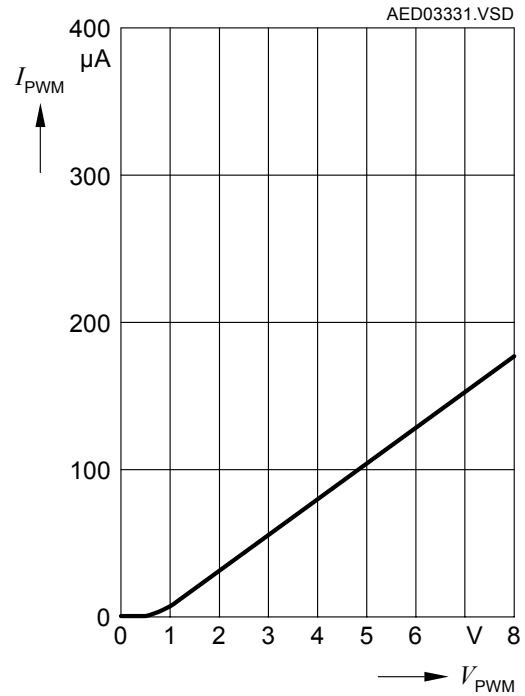

**SET Pin Input Current versus SET Voltage**

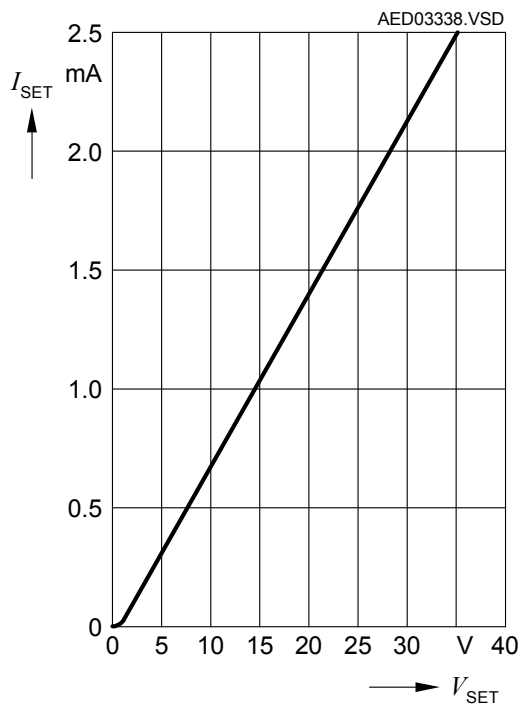

**SET Pin Input Current versus SET Voltage**

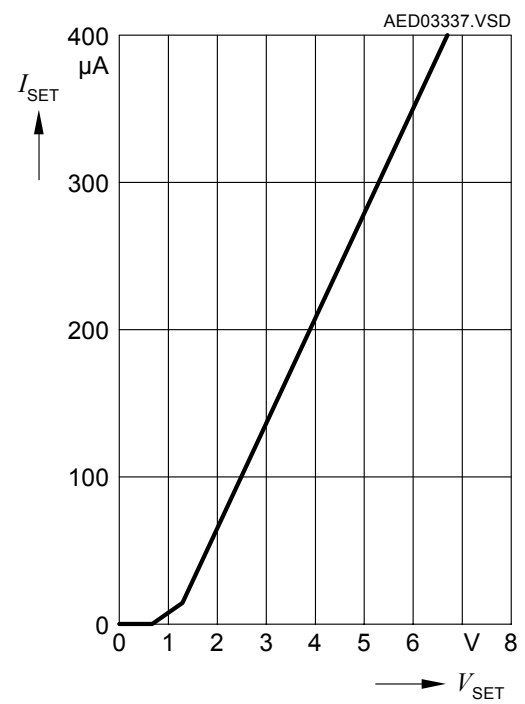

Package Outlines

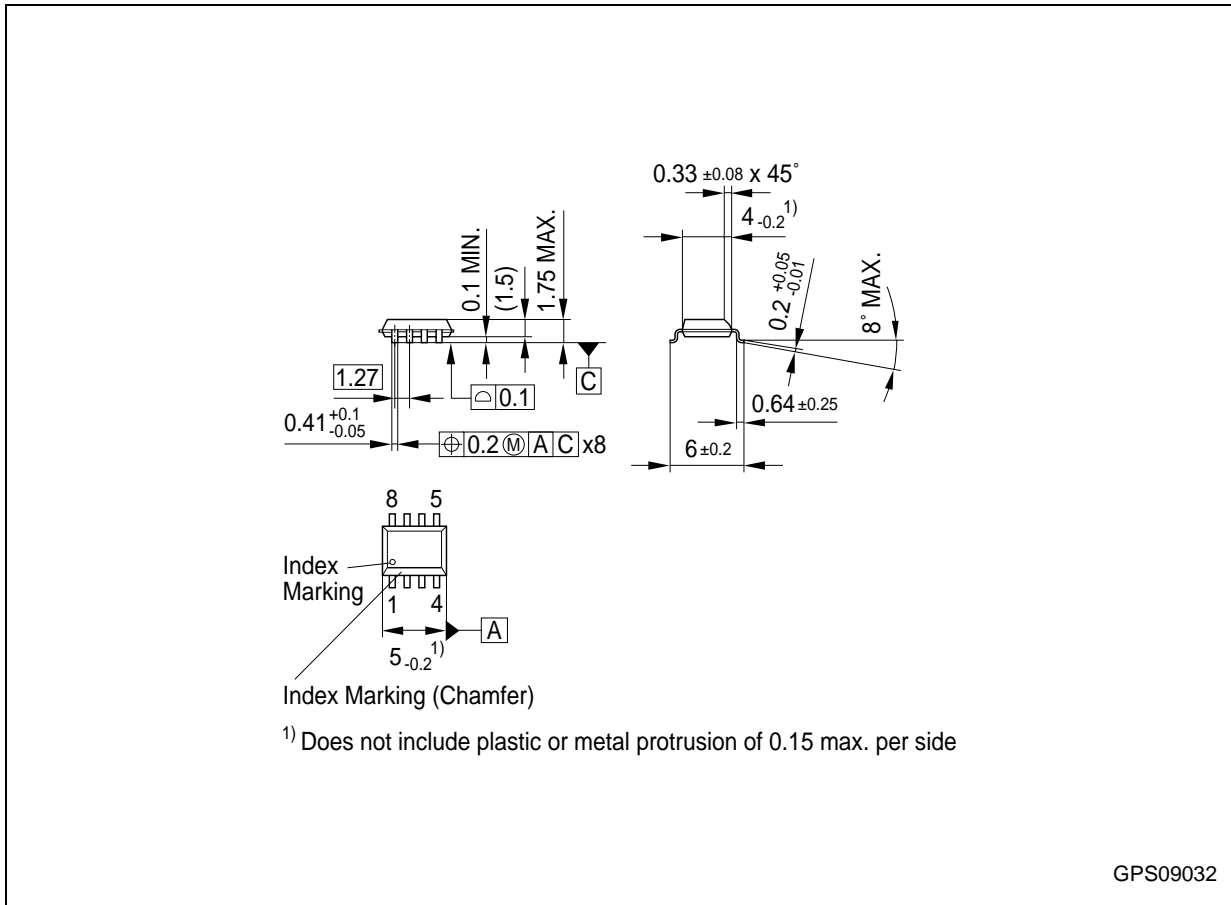

Figure 5 P-DSO-8-9 (Plastic Dual Small Outline)

You can find all of our packages, sorts of packing and others in our Infineon Internet Page "Products": <http://www.infineon.com/products>.

SMD = Surface Mounted Device

Dimensions in mm

---

**Revision History**

<b>Version</b>	<b>Date</b>	<b>Changes</b>
Rev. 1.2	2004-04-13	Page 4, 9: Improved indication and explanation of the open load detection function.

**Edition 2004-04-13**

**Published by Infineon Technologies AG,  
St.-Martin-Strasse 53,  
81669 München, Germany**

**© Infineon Technologies AG 2004.  
All Rights Reserved.**

**Attention please!**

The information herein is given to describe certain components and shall not be considered as a guarantee of characteristics.

Terms of delivery and rights to technical change reserved.

We hereby disclaim any and all warranties, including but not limited to warranties of non-infringement, regarding circuits, descriptions and charts stated herein.

**Information**

For further information on technology, delivery terms and conditions and prices please contact your nearest Infineon Technologies Office ([www.infineon.com](http://www.infineon.com)).

**Warnings**

Due to technical requirements components may contain dangerous substances. For information on the types in question please contact your nearest Infineon Technologies Office.

Infineon Technologies Components may only be used in life-support devices or systems with the express written approval of Infineon Technologies, if a failure of such components can reasonably be expected to cause the failure of that life-support device or system, or to affect the safety or effectiveness of that device or system. Life support devices or systems are intended to be implanted in the human body, or to support and/or maintain and sustain and/or protect human life. If they fail, it is reasonable to assume that the health of the user or other persons may be endangered.