

LED Driver

Features

- LED drive current of 20mA
- Output current adjustable up to 60mA with external resistor
- Supply voltage up to 18V
- Easy paralleling of drivers to increase current
- Low voltage overhead of 1.2V
- High current accuracy at supply voltage variation
- No EMI
- Reduced output current at higher temperatures - negative thermal coefficient of -0.3% / K
- RoHS compliant (pb-free) small SOT343 package
- Qualified according AEC Q101

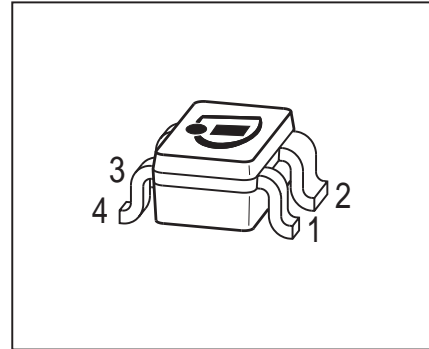

Applications

- Channel letters for advertising, LED strips for decorative lighting
- Aircraft, train, ship illumination
- Retrofits for general lighting, white goods like refrigerator lighting
- Medical lighting

General Description

The BCR402W is a cost efficient LED driver to drive low power LED's. The advantages towards resistor biasing are:

- homogenous light output despite varying forward voltages in different LED strings
- homogenous light output of LED's despite voltage drop across long supply lines
- homogenous light output independent from supply voltage variations
- longer lifetime of the LED's due to reduced output current at higher temperatures (negative thermal coefficient)

The advantages towards discrete solutions are:

- lower assembly cost
- smaller form factor
- better quality due to less soldering points
- higher output current accuracy due to pretested LED drivers

Dimming is possible by using an external digital transistor at the ground pin.

The BCR402W can be operated at higher supply voltages by putting LED's between the power supply +VS and the power supply pin of the LED driver. You can find further details in the application note AN182.

The BCR402W is a perfect fit for numerous low power LED applications by combining small form factor with low cost. These LED drivers offer several advantages to resistors like significantly higher current control at very low voltage drop ensuring high lifetime of LED's.

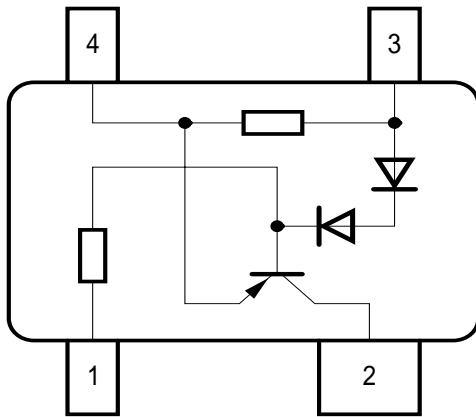
Pin Configuration

EHA07188

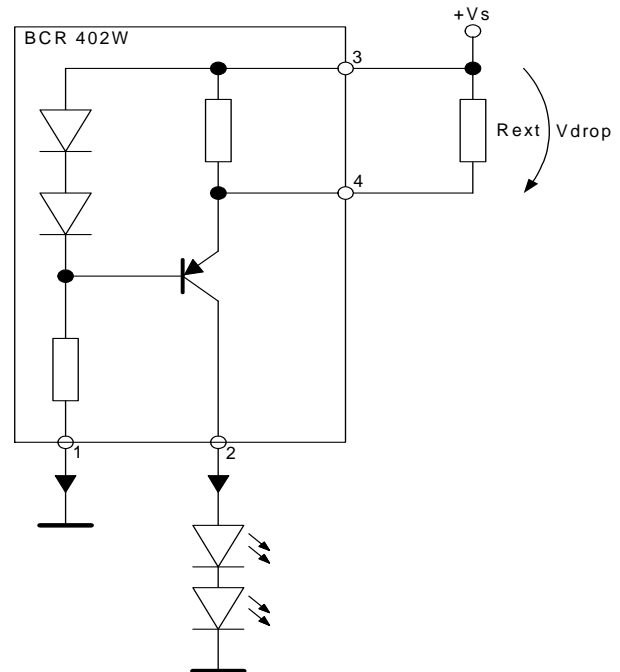
Typical Application

Type	Marking	Pin Configuration				Package
BCR402W	W6s	1 = GND	2 = I_{out}	3 = V_S	4 = R_{ext}	SOT343

Maximum Ratings

Parameter	Symbol	Value	Unit
Supply voltage	V_S	18	V
Output current	I_{out}	60	mA
Output voltage	V_{out}	16	V
Reverse voltage between all terminals	V_R	0.5	
Total power dissipation, $T_S \leq 95\text{ °C}$	P_{tot}	500	mW
Junction temperature	T_j	150	°C
Storage temperature	T_{stg}	-65 ... 150	

Thermal Resistance

Parameter	Symbol	Value	Unit
Junction - soldering point ¹⁾	R_{thJS}	110	K/W

¹⁾For calculation of R_{thJA} please refer to Application Note Thermal Resistance

Electrical Characteristics at $T_A=25^\circ\text{C}$, unless otherwise specified

Parameter	Symbol	Values			Unit
		min.	typ.	max.	
Characteristics					
Collector-emitter breakdown voltage $I_C = 100 \mu\text{A}$, $I_B = 0$	$V_{BR(CEO)}$	18	-	-	-
Supply current $V_S = 10 \text{ V}$	I_S	350	440	540	μA
DC current gain $I_C = 50 \text{ mA}$, $V_{CE} = 1 \text{ V}$	h_{FE}	-	150	-	-
Internal resistor $I_{Rint} = 10 \text{ mA}$	R_{int}	33	38	47	Ω
Output current $V_S = 10 \text{ V}$, $V_{out} = 7.6 \text{ V}$	I_{out}	18	20	22	mA
Voltage drop ($V_S - V_E$) $I_{out} = 20 \text{ mA}$	V_{drop}	-	0.76	-	V
DC Characteristics with stabilized LED load					
Lowest sufficient supply voltage overhead $I_{out} > 8\text{mA}$	V_{Smin}	-	1.2	-	V
Output current change versus T_A $V_S = 10 \text{ V}$	$\Delta I_{out}/I_{out}$	-	-0.3	-	$\%/K$
Output current change versus V_S $V_S = 10 \text{ V}$	$\Delta I_{out}/I_{out}$	-	2	-	$\%/V$

Total power dissipation $P_{tot} = f(T_S)$

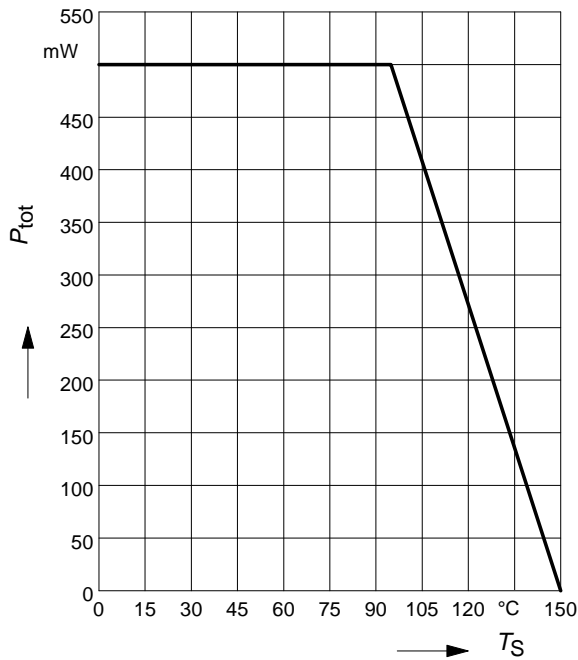

Permissible Pulse Load $R_{thJS} = f(t_p)$

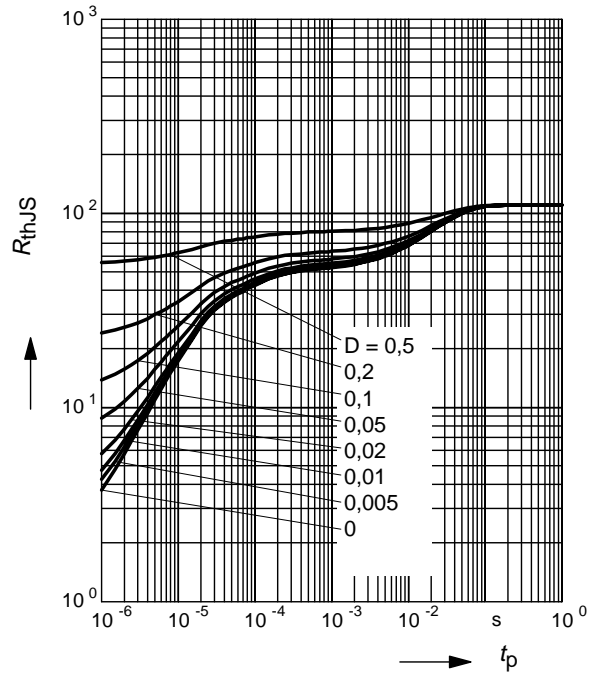

Permissible Pulse Load

$$P_{totmax} / P_{totDC} = f(t_p)$$

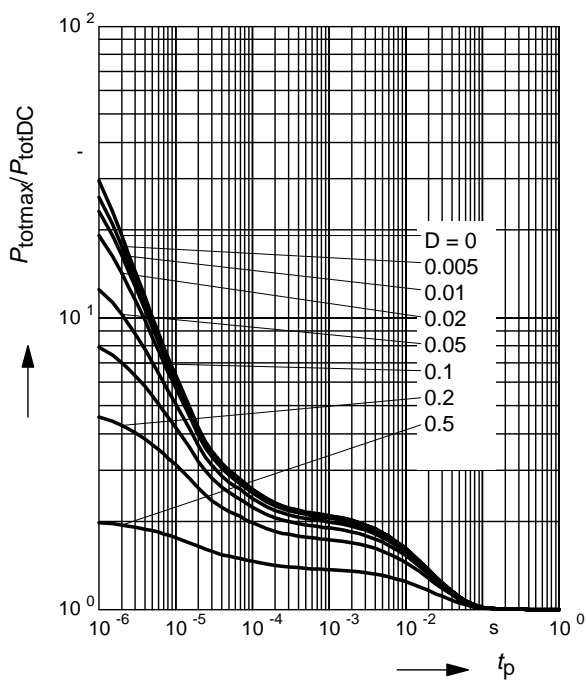

Output current versus supply voltage

$I_{out} = f(V_S); R_{ext} = \text{Parameter}$

Load: two LEDs with $V_F = 3.8V$ in series

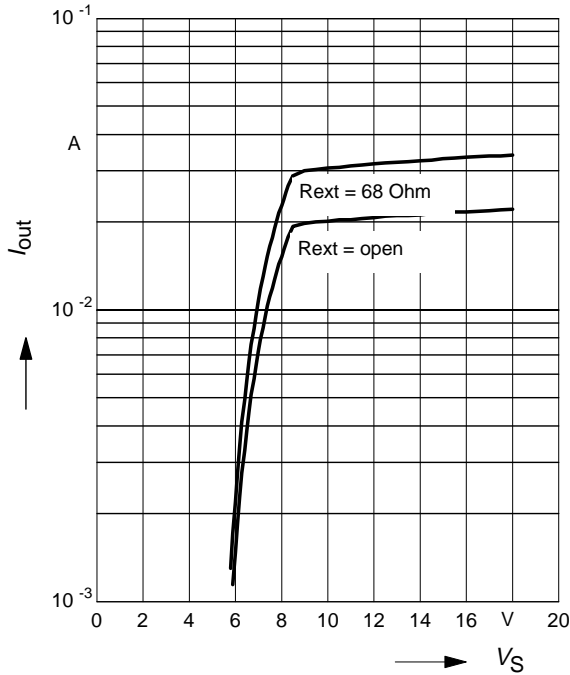

Supply current versus supply voltage

$I_S = f(V_S)$

Load: two LEDs with $V_F = 3.8V$ in series

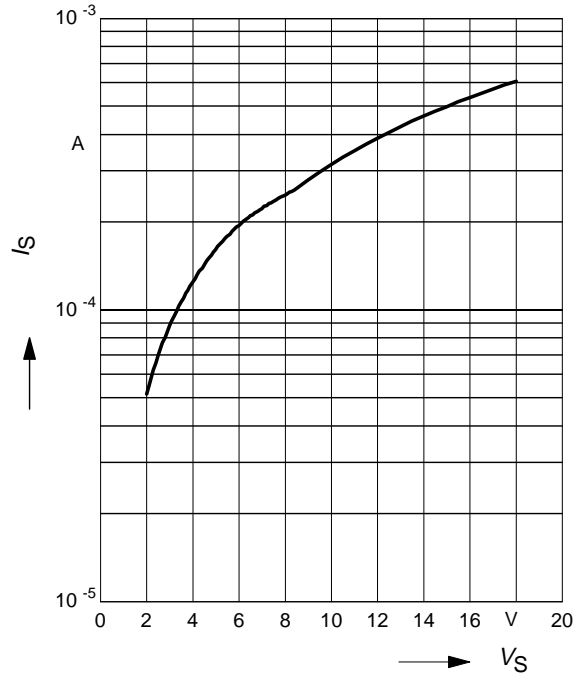

Output current versus external resistor

$I_{out} = f(R_{ext}); V_S = 10V; V_{out} = 7.6V$

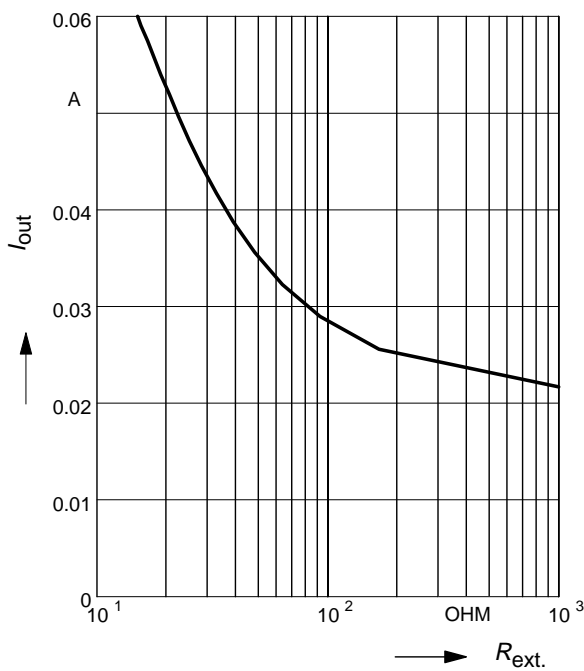

Output current versus reference voltage

$I_{out} = f(V_{DROP}); V_S = 10V; V_{out} = 7.6V$

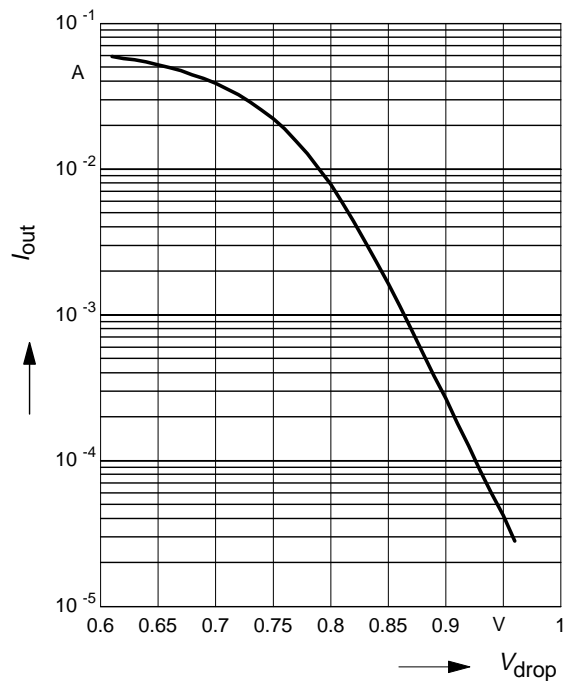

Standard Application Circuit:

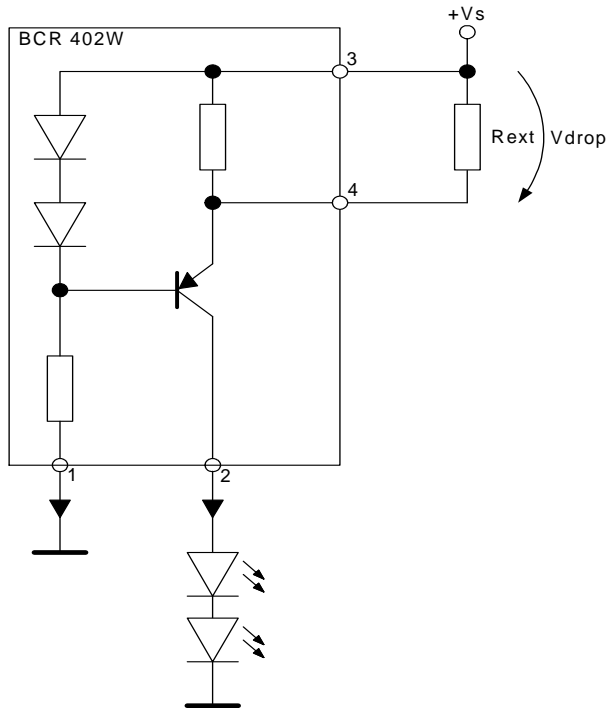

Application Circuit:
supply voltages >18V

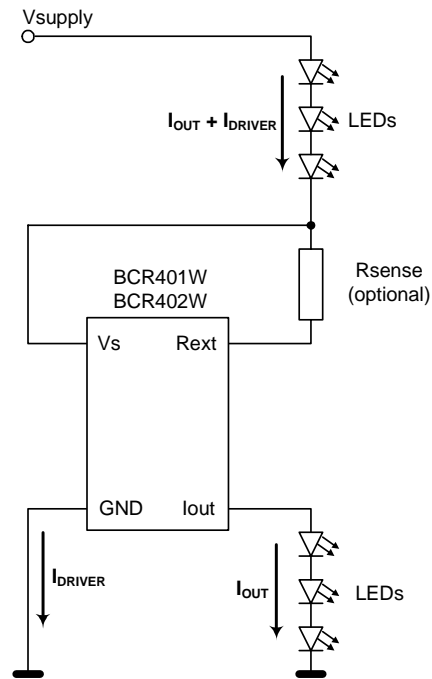

Application hints

BCR402W serves as an easy to use constant current source for LEDs. In stand alone application an external resistor can be connected to adjust the current from 20 mA to 60 mA. Rext can be determined by using the diagram 'Output current versus external resistor', or by referring to diagram 'Output current versus reference voltage'. Look for your desired output current on the y axis and read out the corresponding Vdrop. Calculate Rext:

$$R_{ext} = V_{drop} / (I_{out} - (V_{drop}/R_{int}))$$

Please take into account that the resulting output currents will be slightly lower due to the self heating of the component and the negative thermal coefficient.

Please visit our web site for application notes: www.infineon.com/lowcostleddriver

- AN077 gives hints to thermal design
- AN182 provides a guideline for replacing resistor biasing with BCR401W / BCR402W constant current sources in 12 & 24V striplight applications

Package Outline

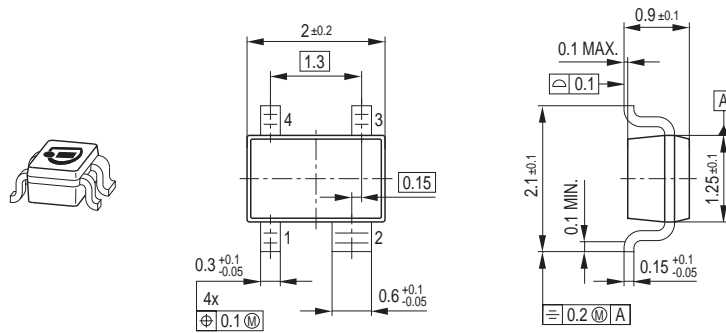

Foot Print

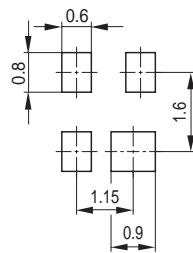

Marking Layout (Example)

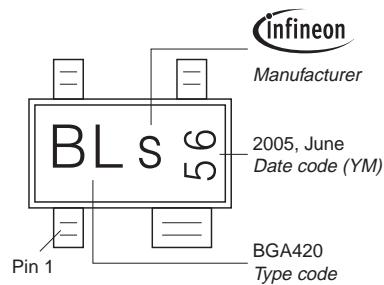

Standard Packing

Reel ø180 mm = 3.000 Pieces/Reel
 Reel ø330 mm = 10.000 Pieces/Reel

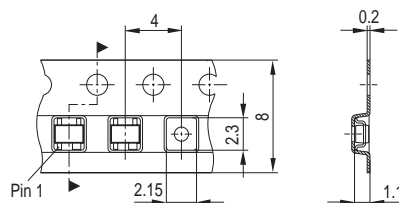

Edition 2009-11-16

**Published by
Infineon Technologies AG
81726 Munich, Germany**

**© 2009 Infineon Technologies AG
All Rights Reserved.**

Legal Disclaimer

The information given in this document shall in no event be regarded as a guarantee of conditions or characteristics. With respect to any examples or hints given herein, any typical values stated herein and/or any information regarding the application of the device, Infineon Technologies hereby disclaims any and all warranties and liabilities of any kind, including without limitation, warranties of non-infringement of intellectual property rights of any third party.

Information

For further information on technology, delivery terms and conditions and prices, please contact the nearest Infineon Technologies Office (www.infineon.com).

Warnings

Due to technical requirements, components may contain dangerous substances. For information on the types in question, please contact the nearest Infineon Technologies Office.

Infineon Technologies components may be used in life-support devices or systems only with the express written approval of Infineon Technologies, if a failure of such components can reasonably be expected to cause the failure of that life-support device or system or to affect the safety or effectiveness of that device or system. Life support devices or systems are intended to be implanted in the human body or to support and/or maintain and sustain and/or protect human life. If they fail, it is reasonable to assume that the health of the user or other persons may be endangered.