

# LM2758

## Switched Capacitor Flash LED Driver in micro SMD

### General Description

LM2758 is an integrated low-noise, high-current switched capacitor DC/DC converter with a regulated current sink. The device is capable of driving loads up to 700 mA from a single-cell Li-Ion battery. Maximum efficiency is achieved over the input voltage range by actively selecting the proper gain based on the LED forward voltage and current requirements.

One external low-power resistor sets the desired current for Indicator, Torch and Flash modes. To protect the devices and the flash LED, internal Time-out circuitry turns off the LM2758 in case of a faulty prolonged Flash mode. Internal soft-start circuitry limits the amount of inrush current during start-up.

LM2758 is offered in National's tiny 12-bump thin micro SMD package.

### Features

- Up to 700 mA Output Current
- Ultra-Small Solution Size
  - No Inductor, Only 4 Capacitors and a resistor Required
  - 1.514 mm x 1.996 mm x 0.6 mm thin micro SMD package
- 90% Peak Efficiency
- Indicator, Torch and Flash Modes
- Time-Out Circuitry Limits Flash Duration to 814 msec. (typ.)
- Adaptive 1x and 1.5x Gains for Maximum Efficiency
- True Shutdown
- Internal Soft-Start Eliminates Inrush Current

### Applications

- Camera Flash in Mobile Phones
- Flash for Digital Cameras

### Typical Application Circuit

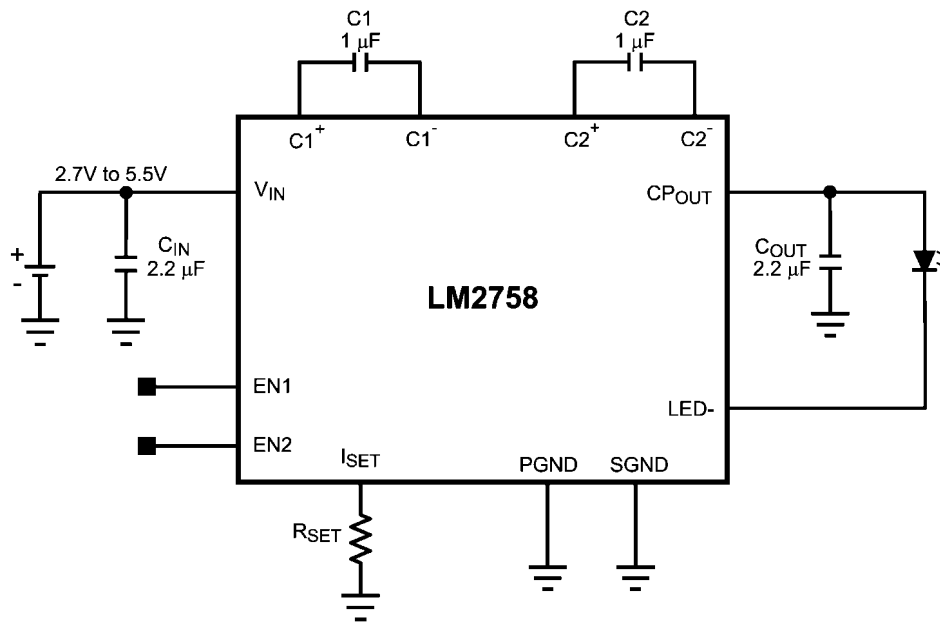

30045301

## Connection Diagram

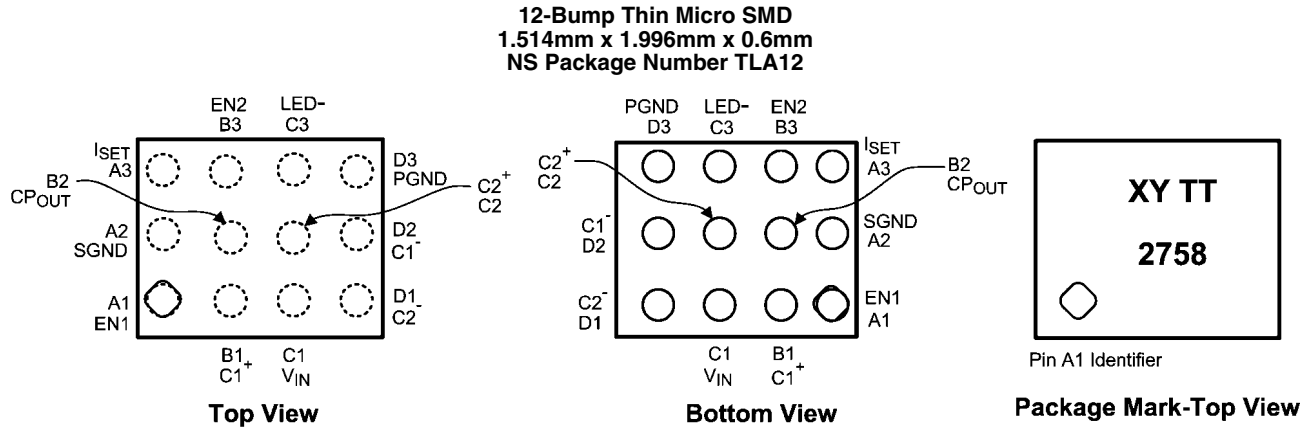

30045302

## Pin Descriptions

Pin	Name	Description
C1	V <sub>IN</sub>	Supply voltage connection.
B2	CP <sub>OUT</sub>	Charge pump regulated output. A 2.2 μF ceramic capacitor is required from CP <sub>OUT</sub> to GND. Connect flash LED anode to this pin.
B1	C1 <sup>+</sup>	Flying capacitor pins. A 1 μF ceramic capacitor should be connected from C1 <sup>+</sup> to C1 <sup>-</sup> and from C2 <sup>+</sup> to C2 <sup>-</sup> .
D2	C1 <sup>-</sup>	
C2	C2 <sup>+</sup>	
D1	C2 <sup>-</sup>	
A2	SGND	Analog and control ground for charge pump. This pin should be connected directly to a low impedance ground plane.
C3	LED-	Regulated current source output. Connect flash LED cathode to this pin.
A1	EN1	The EN1 and EN2 pins are used to select the modes (Torch, Indicator, Flash), as well as to put the part into Shutdown mode.
B3	EN2	
A3	I <sub>SET</sub>	LED current programming resistor pin. A resistor connected between this pin and GND are used to set Torch, Flash and Indicator currents.
D3	PGND	Power ground for the charge pump and the current source. This pin should be connected directly to a low impedance ground plane.

## Ordering Information

Order Number	Supplied as Tape and Reel (Units)
LM2758TL	250 units, tape and reel
LM2758TLX	3000 units, tape and reel

## Absolute Maximum Ratings (Note 1, Note 2)

2)

If Military/Aerospace specified devices are required, please contact the National Semiconductor Sales Office/Distributors for availability and specifications.

$V_{IN}$ , CP <sub>OUT</sub> pins: Voltage to GND	-0.3V to 6.0V
EN1, EN2 pins: Voltage to GND	-0.3V to ( $V_{IN} + 0.3V$ ) w/ 6.0V max

Continuous Power Dissipation  
(Note 3) Internally Limited

Junction Temperature ( $T_{J-MAX}$ ) 150°C

Storage Temperature Range -65°C to 150°C

Maximum Lead Temp. (Soldering) (Note 5)

ESD Ratings (Note 4)

Human Body Model 2kV

Machine Model 200V

## Operating Ratings (Note 1, Note 2)

Input Voltage Range 2.7V to 5.5V

Junction Temperature Range ( $T_J$ ) -40°C to +125°C

Ambient Temperature Range ( $T_A$ )  
(Note 6) -40°C to +85 °C

## Thermal Information

Junction-to-Ambient Thermal Resistance 56°C/W

Resistance ( $\theta_{JA}$ ), micro SMD package  
(Note 7)

## ESD Caution Notice

National Semiconductor recommends that all integrated circuits be handled with appropriate ESD precautions. Failure to observe proper ESD handling techniques can result in damage to the device.

## Electrical Characteristics (Note 2, Note 8)

Limits in standard typeface are for  $T_J = 25^\circ\text{C}$ . Limits in **boldface** type apply over the full operating junction temperature range ( $-40^\circ\text{C} \leq T_J \leq +125^\circ\text{C}$ ). Unless otherwise noted, specifications apply to the LM2758 Typical Application Circuit (pg.1) with  $V_{IN} = 3.6V$ ,  $V_{EN1} = V_{IN}$ ,  $V_{EN2} = 0V$ ,  $C1 = C2 = 1 \mu\text{F}$ ,  $C_{IN} = C_{OUT} = 2.2 \mu\text{F}$ ,  $R_{SET} = 20 \text{ k}\Omega$  (Note 9).

Symbol	Parameter	Conditions	Min	Typ	Max	Units
$I_{LED}$	LED Current Accuracy	$I_{LED} = 500 \text{ mA}$ , Flash Mode	<b>450</b>	500	<b>550</b>	mA
$V_{SET}$	$I_{SET}$ Pin Voltage			1.3		V
$I_D/I_{SET}$	LED Current to Set Current Ratio	Flash Mode		7650		
		Torch Mode		1639		
$I_{LED-IND}$	Indicator Current Level	Indicator Mode 32 kHz PWM Mode		$1/32 \times I_{LED-TORCH}$		mA
$V_{GDX}$	1x to 1.5x Gain Transition Voltage Threshold on $V_{LED^-}$	$I_{OUT} = 500 \text{ mA}$		300		mV
$V_{OUT}$	Output Voltage	1x Mode, $I_{OUT} = 0 \text{ mA}$		$V_{IN}$		V
		1.5x Mode, $I_{OUT} = 0 \text{ mA}$ (Note 10)		4.8	<b>5.3</b>	
$R_{OUT}$	1x Mode Output Impedance	$I_{OUT} = 200 \text{ mA}$ , $V_{IN} = 3.3V$		0.33	<b>0.53</b>	$\Omega$
	1.5x Mode Output Impedance	$I_{OUT} = 500 \text{ mA}$ , $V_{IN} = 3.3V$ (Note 11)		1.5	2.0	
$F_{SW}$	Switching Frequency		<b>0.8</b>	1.25	<b>1.5</b>	MHz
$I_Q$	Quiescent Current	$I_{OUT} = 0 \text{ mA}$ 1x Mode		0.7	<b>0.8</b>	mA
		$I_{OUT} = 0 \text{ mA}$ 1.5x Mode		4	<b>5</b>	
$I_{SD}$	Shutdown Current	Device Disabled (Note 12)		0.01	<b>1</b>	$\mu\text{A}$
$T_{OUT}$	Time-out Duration	(Note 13)	<b>640</b>	814	<b>1000</b>	msec
$V_{IH}$	Input Logic High	Pins: EN1, EN2	<b>1.2</b>			V
$V_{IL}$	Input Logic Low	Pins: EN1, EN2			<b>0.4</b>	V

**Note 1:** Absolute Maximum Ratings indicate limits beyond which damage to the component may occur. Operating Ratings are conditions under which operation of the device is guaranteed. Operating Ratings do not imply guaranteed performance limits. For guaranteed performance limits and associated test conditions, see the Electrical Characteristics tables.

**Note 2:** All voltages are with respect to the potential to the GND pin.

**Note 3:** Internal thermal shutdown circuitry protects the device from permanent damage. Thermal shutdown engages at  $T_J=150^{\circ}\text{C}$  (typ.) and disengages at  $T_J = 140^{\circ}\text{C}$  (typ.).

**Note 4:** The Human body model is a 100 pF capacitor discharged through a 1.5 k $\Omega$  resistor into each pin. The machine model is a 200pF capacitor discharged directly into each pin. MIL-STD-883 3015.7

**Note 5:** For detailed soldering specifications and information, please refer to National Semiconductor Application Note AN-1112.

**Note 6:** In applications where high power dissipation and/or poor package thermal resistance is present, the maximum ambient temperature may have to be derated. Maximum ambient temperature ( $T_{A-MAX}$ ) is dependent on the maximum operation junction temperature ( $T_{J-MAX-OP} = 125^{\circ}\text{C}$ ), the maximum power dissipation of the device in the application ( $P_{D-MAX}$ ), and the junction-to ambient thermal resistance of the part/package in the application ( $\theta_{JA}$ ), as given by the following equation:  $T_{A-MAX} = T_{J-MAX-OP} - (\theta_{JA} \times P_{D-MAX})$ .

**Note 7:** Junction-to-ambient thermal resistance ( $\theta_{JA}$ ) is taken from a thermal modeling result, performed under the conditions and guidelines set forth in the JEDEC standard JESD51-7. The test board is a 4-layer FR-4 board measuring 102 mm x 76 mm x 1.6 mm with a 2x1 array of thermal vias. The ground plane on the board is 50 mm x 50 mm. Thickness of copper layers are 53 $\mu\text{m}/35\mu\text{m}/35\mu\text{m}/53\mu\text{m}$  (1.5oz/1oz/1oz/1.5oz). Ambient temperature in simulation is 22 $^{\circ}\text{C}$ , still air. Power dissipation is 1W.

The value of  $\theta_{JA}$  of this product in this micro SMD could fall in a range as wide as 50 $^{\circ}\text{C}/\text{W}$  to 150 $^{\circ}\text{C}/\text{W}$  (if not wider), depending on PWB material, layout, and environmental conditions. In applications where high maximum power dissipation exists (high  $V_{IN}$ , high  $I_{OUT}$ ), special care must be paid to thermal dissipation issues.

**Note 8:** Min and Max limits are guaranteed by design, test, or statistical analysis. Typical (Typ) numbers are not guaranteed, but do represent the most likely norm. Unless otherwise specified, conditions for Typ specifications are:  $V_{IN} = 3.6\text{V}$  and  $T_A = 25^{\circ}\text{C}$ .

**Note 9:**  $C_{IN}$ ,  $C_{OUT}$ , C1, C2: Low-ESR Surface-Mount Ceramic Capacitors (MLCCs) used in setting electrical characteristics.

**Note 10:** Output voltage is internally limited not to exceed maximum specified value.

**Note 11:** These specification table entries are guaranteed by design. These parameters are not guaranteed by production testing. The temperature limits for test are ( $-40^{\circ}\text{C} \leq T_A \leq +85^{\circ}\text{C}$ ).

**Note 12:** The temperature limits for  $I_{SD}$  (shutdown current) test are  $-40^{\circ}\text{C} \leq T_A \leq +85^{\circ}\text{C}$ , as in Shutdown mode ambient temperature is equal to junction temperature.

**Note 13:** The time-out specifications are calculated values based on the switching frequency spread.

## Block Diagram

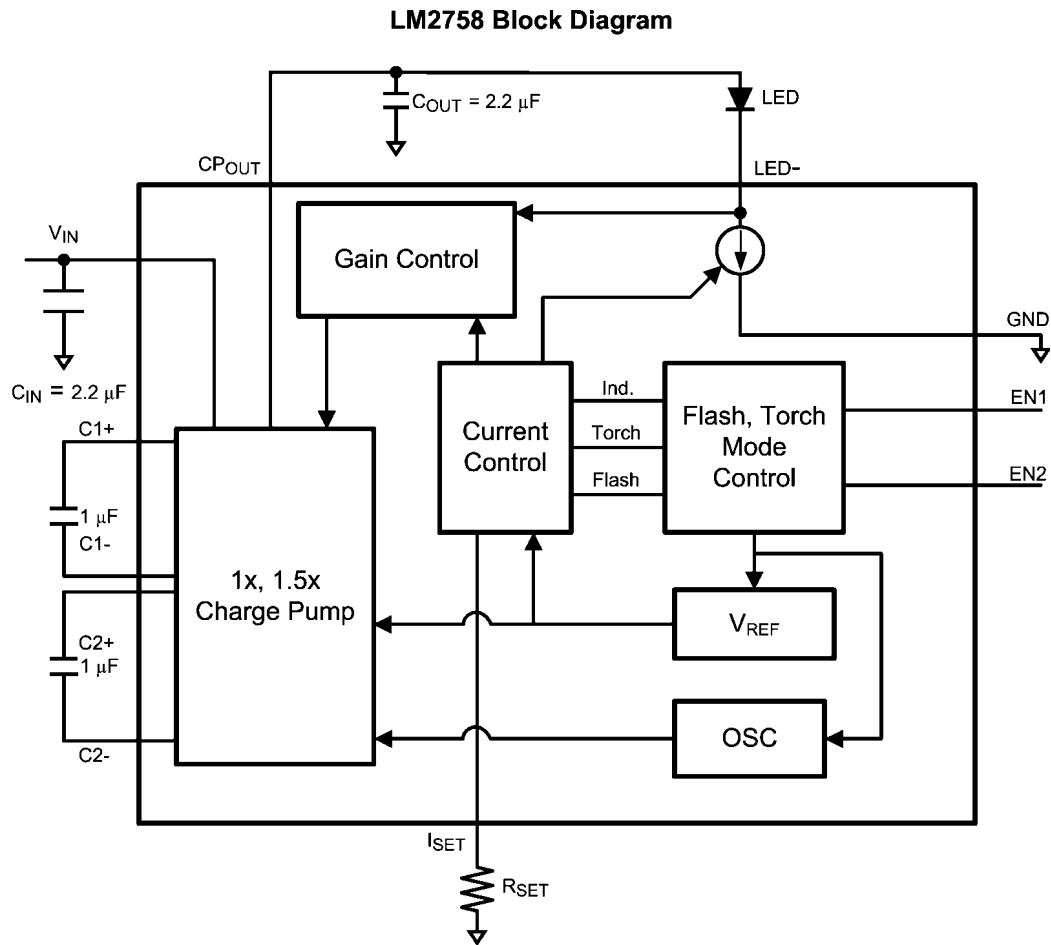

30045319

## Typical Performance Characteristics

Unless otherwise specified:  $T_A = 25^\circ\text{C}$ ,  $V_{IN} = 3.6\text{V}$ ,  $C_{IN} = C_{OUT} = 2.2\ \mu\text{F}$ ,  $C1 = C2 = 1\ \mu\text{F}$ . Capacitors are low-ESR multi-layer ceramic capacitors (MLCC's). Luxeon PWF1 Flash LED.

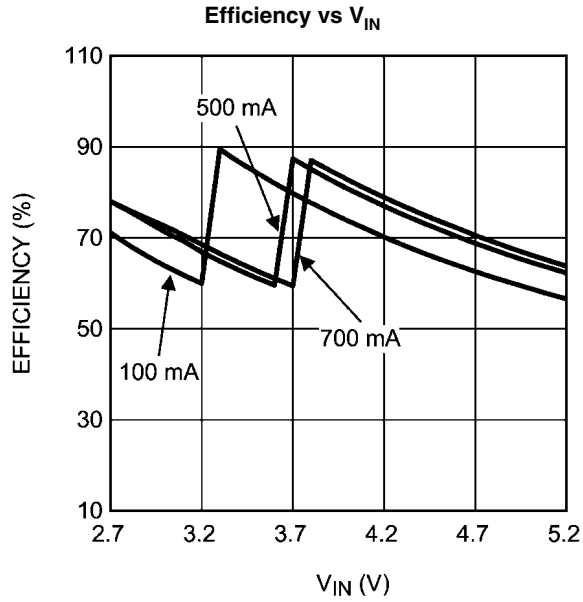

30045304

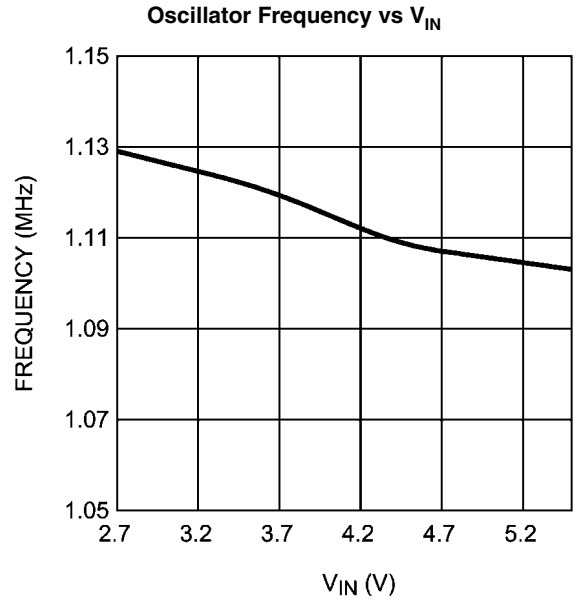

30045305

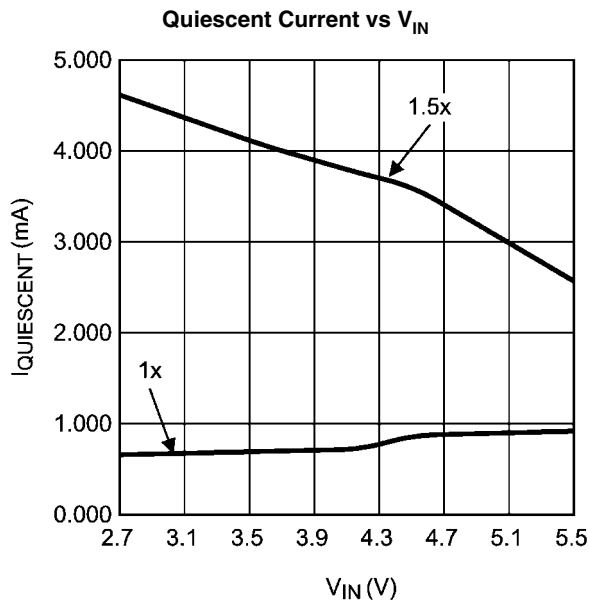

30045306

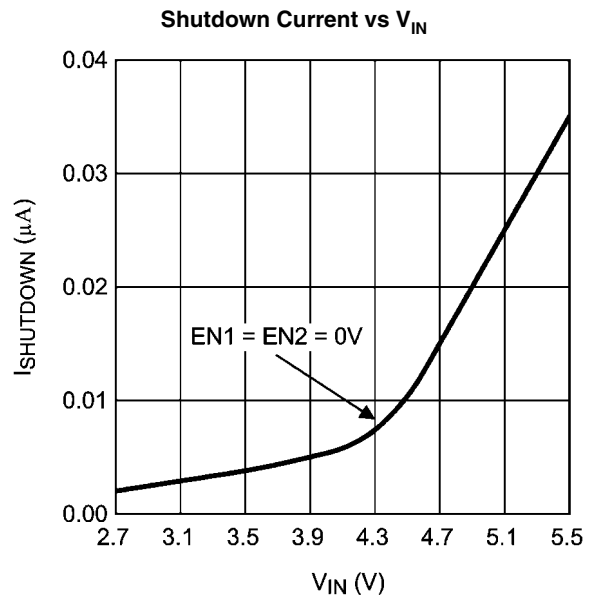

30045307

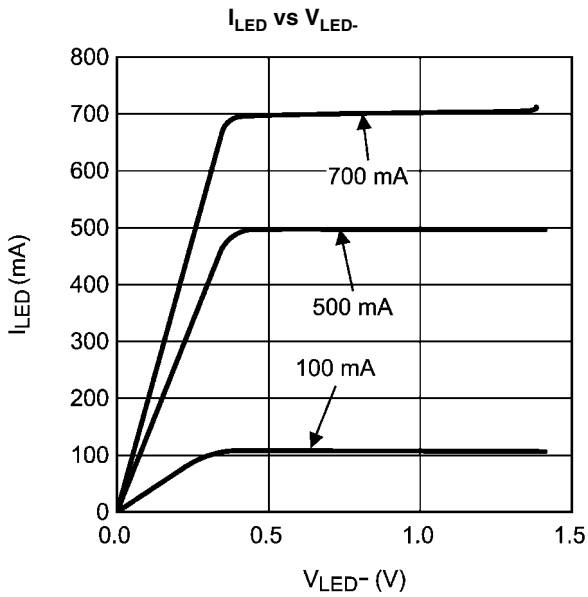

30045308

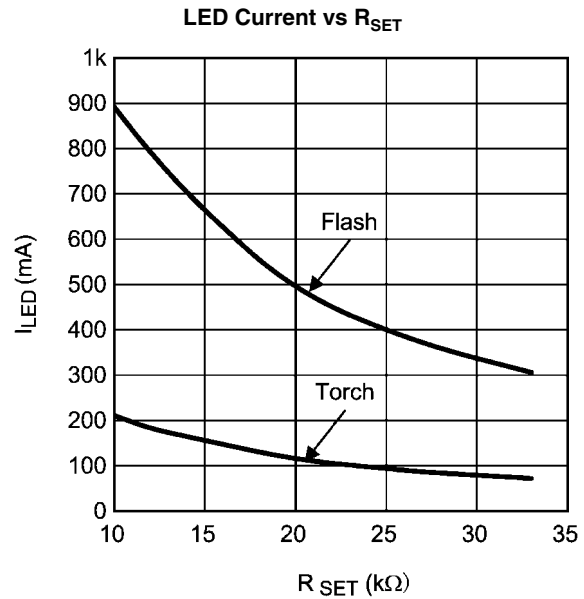

30045309

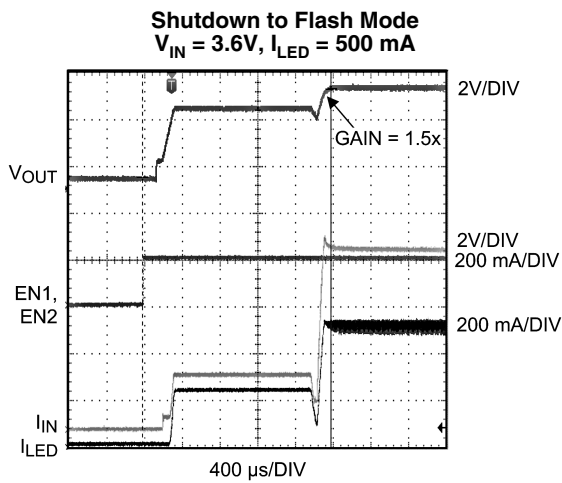

30045310

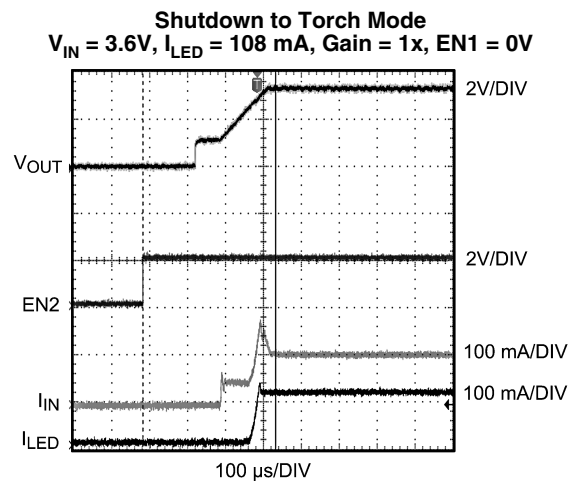

30045311

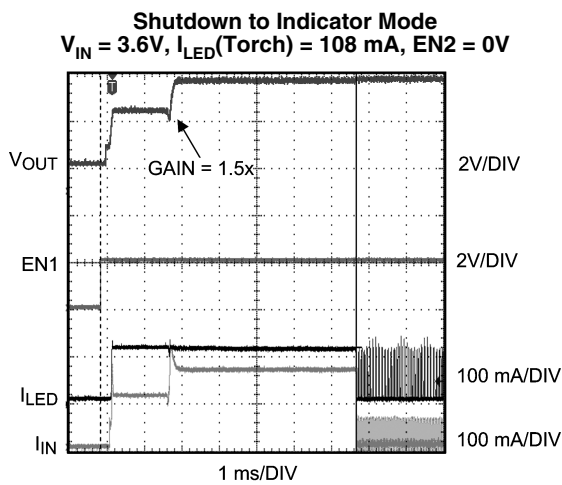

30045312

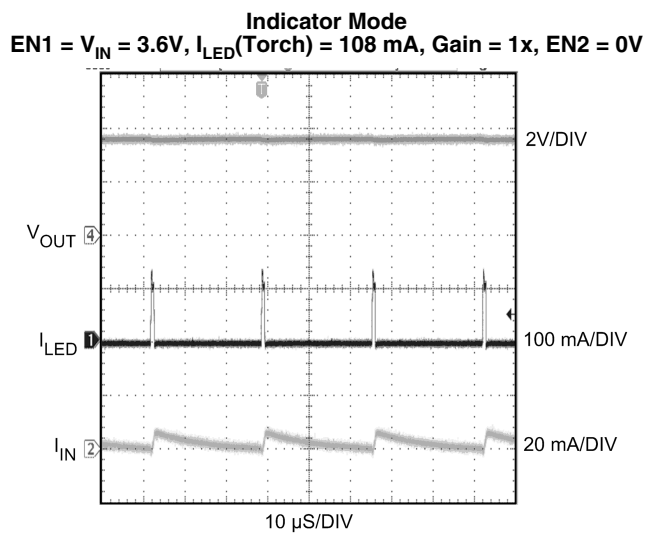

30045313

**Torch to Flash Mode Transition**  
 $EN2 = V_{IN} = 3.6V, I_{LED(Flash)} = 500\text{ mA}, \text{Gain} = 1.5x$

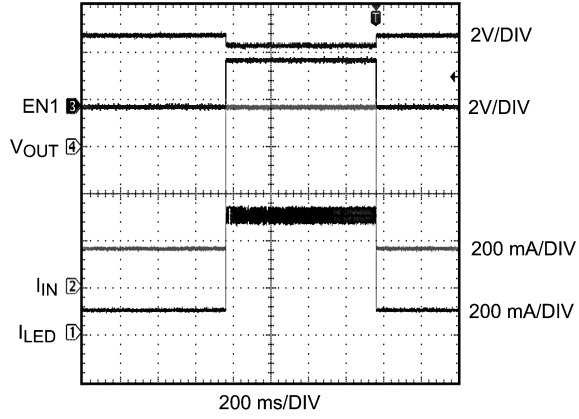

30045314

**Indicator to Flash Mode Transition**  
 $EN1 = V_{IN} = 3.6V, I_{LED(Flash)} = 500\text{ mA}, \text{Gain} = 1.5x$

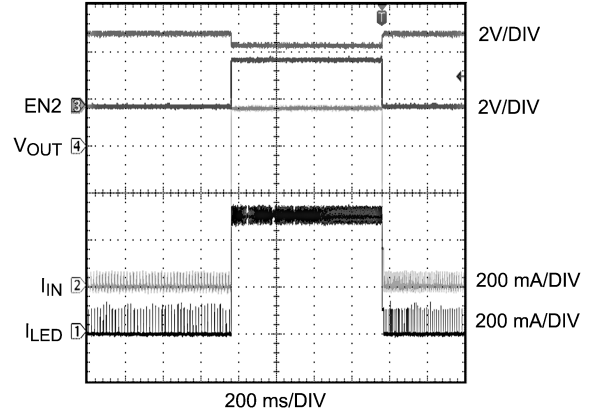

30045315



## Application Information

### CIRCUIT DESCRIPTION

The LM2758 is an adaptive 1x and 1.5x CMOS charge pump, optimized for driving Flash LEDs in camera phone and other portable applications. It provides a constant current of 500 mA (typ.) for Flash mode and 107 mA (typ.) for Torch mode with  $R_{SET} = 20\text{ k}\Omega$ . These current can change, see [SETTING LED CURRENTS](#).

There are four modes of operation for LM2758: the Flash Mode, Torch Mode, Indicator Mode and Shutdown Mode (see EN1 and EN2 truth table). Torch and Flash modes sink a constant DC current while Indicator mode operates in pulsating DC at 1/32 positive duty cycle with same current magnitude as Torch mode. The LED is driven from  $CP_{OUT}$  and connected to the current sink. LED drive current mode is programmed by connecting a resistor,  $R_{SET}$ , to the current set pin,  $I_{SET}$ . LM2758 also controls  $CP_{OUT}$  with variable gain (1x or 1.5x) and adjustable impedance ( $R_{OUT}$ ) to provide an output voltage that would account for LED forward voltage drop and headroom for the current sink to drive desired current through LED.

### CHARGE PUMP AND GAIN TRANSITIONS

The input to the 1x/1.5x charge pump is connected to the  $V_{IN}$  pin, and the loosely regulated output of the charge pump is connected to the  $CP_{OUT}$  pin. In 1x mode, as long as the input voltage is less than 4.7V, the output voltage is approximately equal to the input voltage. When input voltage is over 4.7V the output voltage gets regulated to 4.7V. In 1.5x mode, the output voltage is always less than or equal to 4.7V over entire input voltage range.

The charge pump's gain is selected depending on the headroom voltage across the current sink of LM2758. When headroom voltage  $V_{LED}$  (at LED pin) drops below 300 mV (typ.) the charge pump gain transition happens from 1x to 1.5x to maintain current regulation across the LED. Once the charge pump transition to a higher gain, it will remain at that gain for as long as the device remains enabled. Shutting down and then re-enabling the device will resets the gain mode to the minimum gain required to maintain the load.

### SOFT START

The LM2758 contains internal soft-start circuitry to limit inrush currents when the part is enabled. Soft start is implemented internally with a controlled turn-on of the internal voltage reference.

### CURRENT LIMIT PROTECTION

The LM2758 charge pump contains current limit protection circuitry that protects the device during  $V_{OUT}$  fault conditions

where excessive current is drawn. Output current is limited to 1.2A typically.

### LOGIC CONTROL PINS

LM2758 has two logic pins, EN1 and EN2. The operating modes of the part function according to the tables below:

EN1	EN2	Mode
0	0	Shutdown
1	0	Indicator
0	1	Torch
1	1	Flash

### FLASH TIME-OUT FEATURE

Flash Time-out Protection Circuitry disables the current sinks when the signal on EN1 and EN2 is held high for more than 814 msec (typ.). This prevents the device from self-heating due to the high power dissipation during Flash conditions. During the time-out condition, voltage will still be present on  $CP_{OUT}$  but the current sinks will be shut off, resulting in no current through the Flash LED. When the device goes into a time-out condition, placing a logic Low signal on EN1 and EN2 will reset the time-out; a subsequent logic High signal on EN1 or EN2 will return the device to normal operation.

### SETTING LED CURRENTS

The current through the LED can be set by connecting an appropriately sized resistor  $R_{SET}$  between the  $I_{SET}$  pin of the LM2758 and GND.

The LED current in Torch mode is approximately 1639 times greater than the current of  $I_{SET}$ , while the LED current in Flash mode is approximately 7650 times of the same  $I_{SET}$  current. The feedback loop of an internal amplifier sets the voltage of the  $I_{SET}$  pin to 1.3V (typ.). The statements above are simplified in the equations below:

$$I_{LED} = \text{GAIN}_{FLASH/TORCH} \times (1.3/R_{SET})$$

The maximum recommended current through LED is 500 mA in Torch mode / 700 mA in Flash mode. Note: If the  $I_{SET}$  for Torch Mode setting at 500 mA, the Flash mode would be over 700 mA (max). See the graph LED Current vs  $R_{SET}$ . Using the part in conditions where the junction temperature might rise above the rated maximum requires that the operating ranges and/or conditions be de-rated. The printed circuit board also must be carefully laid out to account for high thermal dissipation in the part.

## ANALOG BRIGHTNESS CONTROL

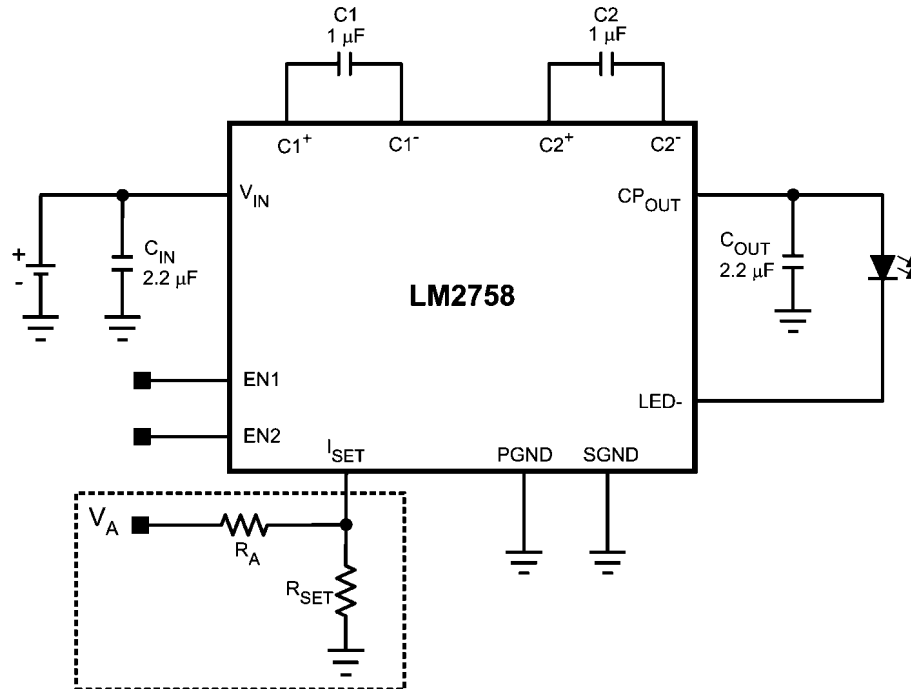

The current through the LED could be varied dynamically by changing the  $I_{SET}$  current. The above figure shows the circuit. The current through the LED can be calculated as follows.

$$I_{LED} = Gain_{TORCH/FLASH} \left[ \frac{1.3V}{R_{SET}} - \frac{V_A - 1.3V}{R_A} \right]$$

30045317

## CAPACITOR SELECTION

The LM2758 requires 4 external capacitors for proper operation. Surface-mount multi-layer ceramic capacitors are recommended. These capacitors are small, inexpensive and have very low equivalent series resistance (ESR <20 mΩ typ.). Tantalum capacitors, OS-CON capacitors, and aluminum electrolytic capacitors are not recommended for use with the LM2758 due to their high ESR, as compared to ceramic capacitors. For most applications, ceramic capacitors with X7R or X5R temperature characteristic are preferred for use with the LM2758. These capacitors have tight capaci-

30045318  
 tance tolerance (as good as  $\pm 10\%$ ) and hold their value over temperature (X7R:  $\pm 15\%$  over  $-55^\circ\text{C}$  to  $125^\circ\text{C}$ ; X5R:  $\pm 15\%$  over  $-55^\circ\text{C}$  to  $85^\circ\text{C}$ ). Capacitors with Y5V or Z5U temperature characteristic are generally not recommended for use with the LM2758. Capacitors with these temperature characteristics typically have wide capacitance tolerance ( $+80\%$ ,  $-20\%$ ) and vary significantly over temperature (Y5V:  $+22\%$ ,  $-82\%$  over  $-30^\circ\text{C}$  to  $+85^\circ\text{C}$  range; Z5U:  $+22\%$ ,  $-56\%$  over  $+10^\circ\text{C}$  to  $+85^\circ\text{C}$  range). Under some conditions, a nominal  $1 \mu\text{F}$  Y5V or Z5U capacitor could have a capacitance of only  $0.1 \mu\text{F}$ . Such detrimental deviation is likely to cause Y5V and Z5U capacitors to fail to meet the minimum capacitance requirements of the LM2758. The voltage rating of the output capacitor should be 6.3V or more. For example, a 6.3V 0603 2.2  $\mu\text{F}$  output capacitor (TDK C1608X5R0J225) is acceptable for use with the LM2758, as long as the capacitance on the output does not fall below a minimum of  $1 \mu\text{F}$  in the intended application. All other capacitors should have a voltage rating at or above the maximum input voltage of the application and should have a minimum capacitance of  $1 \mu\text{F}$ .

## Suggested Capacitors and Suppliers

MFG Part No.	Type	MFG	Voltage Rating	Case Size Inch (mm)
<b>2.2 <math>\mu\text{F}</math> for <math>C_{IN}</math> and <math>C_{OUT}</math></b>				
C1608X5R0J225	Ceramic X5R	TDK	6.3V	0603 (1608)
JMK107BJ225	Ceramic X5R	Taiyo-Yuden	6.3V	0603 (1608)
<b>1 <math>\mu\text{F}</math> for <math>C_1</math> and <math>C_2</math></b>				
C1608X5R0J105	Ceramic X5R	TDK	6.3V	0603 (1608)
JMK107BJ105M	Ceramic X5R	Taiyo-Yuden	6.3V	0603 (1608)

## POWER EFFICIENCY

Efficiency of LED drivers is commonly taken to be the ratio of power consumed by the LEDs ( $P_{LED}$ ) to the power drawn at the input of the part ( $P_{IN}$ ). With a 1x/1.5x charge pump, the input current is equal to the charge pump gain times the output current (total LED current). The efficiency of the LM2758 can be predicted as follows:

$$\begin{aligned} P_{LED} &= V_{LED} \times I_{LED} \\ P_{IN} &= V_{IN} \times I_{IN} \\ P_{IN} &= V_{IN} \times (\text{Gain} \times I_{LED} + I_Q) \\ E &= (P_{LED} \div P_{IN}) \end{aligned}$$

For a simple approximation, the current consumed by internal circuitry ( $I_Q$ ) can be neglected, and the resulting efficiency will become:

$$E = V_{LED} \div (V_{IN} \times \text{Gain})$$

Neglecting  $I_Q$  will result in a slightly higher efficiency prediction, but this impact will be negligible due to the value of  $I_Q$  being very low compared to the typical Torch and Flash current levels (100-500 mA). It is also worth noting that efficiency as defined here is in part dependent on LED voltage. Variation in LED voltage does not affect power consumed by the circuit and typically does not relate to the brightness of the LED. For an advanced analysis, it is recommended that power consumed by the circuit ( $V_{IN} \times I_{IN}$ ) be evaluated rather than power efficiency.

## THERMAL PROTECTION

Internal thermal protection circuitry disables the LM2758 when the junction temperature exceeds 150°C (typ.). This feature protects the device from being damaged by high die temperatures that might otherwise result from excessive power dissipation. The device will recover and operate normally when the junction temperature falls below 140°C (typ.). It is important that the board layout provide good thermal conduction to keep the junction temperature within the specified operating ratings.

## POWER DISSIPATION

The power dissipation ( $P_{DISSIPATION}$ ) and junction temperature ( $T_J$ ) can be approximated with the equations below.  $P_{IN}$  is the power generated by the 1x/1.5x charge pump,  $P_{LED}$  is the power consumed by the LEDs,  $T_A$  is the ambient temperature, and  $\theta_{JA}$  is the junction-to-ambient thermal resistance for the 12-bump micro SMD package.  $V_{IN}$  is the input voltage to the LM2758,  $V_{LED}$  is the nominal LED forward voltage, and  $I_{LED}$  is the programmed LED current.

$$\begin{aligned} P_{DISSIPATION} &= P_{IN} - P_{LED} \\ &= (\text{Gain} \times V_{IN} \times I_{LED}) - (V_{LED} \times I_{LED}) \\ T_J &= T_A + (P_{DISSIPATION} \times \theta_{JA}) \end{aligned}$$

The junction temperature rating takes precedence over the ambient temperature rating. The LM2758 may be operated outside the ambient temperature rating, so long as the junction

temperature of the device does not exceed the maximum operating rating of 125°C. The maximum ambient temperature rating must be derated in applications where high power dissipation and/or poor thermal resistance causes the junction temperature to exceed 125°C.

## MICRO SMD PACKAGE ASSEMBLY AND USE

Use of the micro SMD package requires specialized board layout, precision mounting and careful re-flow techniques as detailed in National Semiconductor Application Note 1112. Refer to the section "Surface Mount Technology (SMD) Assembly Considerations". For best results in assembly, alignment ordinals on the PC board should be used to facilitate placement of the device. The pad style used with the micro SMD package must be the NSMD (non-solder mask defined) type. This means that the solder-mask opening is larger than the pad size. This prevents a lip that otherwise forms if the solder mask and pad overlap, from holding the device off the surface of the board and interfering with mounting. See Application Note 1112 for specific instructions how to do this. The 12-bump package used for LM2758 has 300 micron solder balls and requires 10.82 mils pads for mounting on the circuit board. The trace to each pad should enter the pad with a 90° entry angle to prevent debris from being caught in deep corners. Initially, the trace to each pad should be 7 mil. wide, for a section approximately 7 mil. long or longer, as a thermal relief. Then each trace should neck up or down to its optimal width. The important criteria is symmetry. This ensures the solder bumps on the LM2758 re-flow evenly and that the device solders level to the board. In particular, special attention must be paid to the pads for bumps C1 and D3, because  $V_{IN}$  and GND are typically connected to large copper planes, thus inadequate thermal relief can result in late or inadequate re-flow of these bumps.

The micro SMD package is optimized for the smallest possible size in applications with red or infrared opaque cases. Because the micro SMD package lacks the plastic encapsulation characteristic of larger devices, it is vulnerable to light. Backside metallization and/or epoxy coating, along with front side shading by the printed circuit board, reduce this sensitivity. However, the package has exposed die edges. In particular, micro SMD devices are sensitive to light, in the red and infrared range, shining on the package's exposed die edges.

## BOARD LAYOUT CONSIDERATIONS

PC board layout is an important part of DC-DC converter design. Poor board layout can disrupt the performance of a DC-DC converter and surrounding circuitry by contributing to EMI, ground bounce, and resistive voltage loss in the traces. These can send erroneous signals to the DC-DC converter IC, resulting in poor regulation or instability. Poor layout can also result in re-flow problems leading to poor solder joints between the micro SMD package and board pads. Poor solder joints can result in erratic or degraded performance.

**Physical Dimensions** inches (millimeters) unless otherwise noted

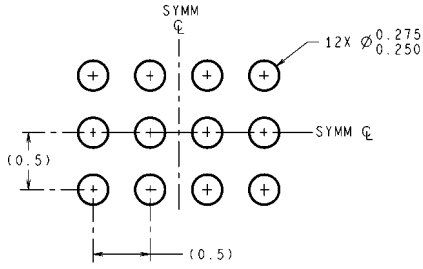

DIMENSIONS ARE IN MILLIMETERS  
DIMENSIONS IN ( ) FOR REFERENCE ONLY

**LAND PATTERN RECOMMENDATION**

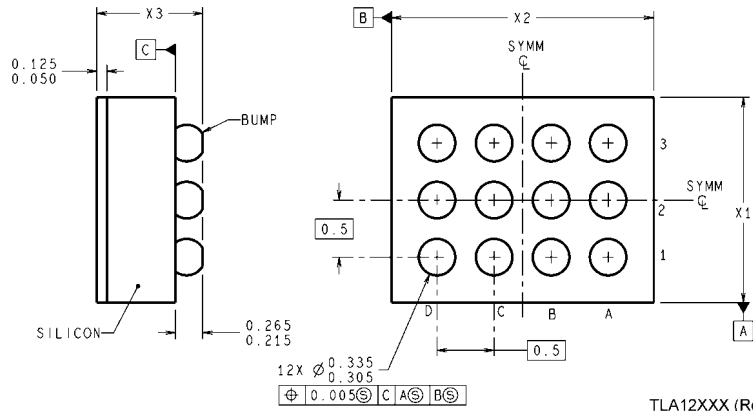
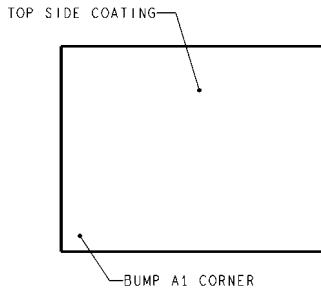

TLA12XXX (Rev C)

**12-bump micro SMD**  
**NS Package Number TLA12**  
**X1 = 1.514 mm ± 30 μm**  
**X2 = 1.996 mm ± 30 μm**  
**X3 = 0.600 mm ± 75 μm**

# Notes

LM2758

## Notes

For more National Semiconductor product information and proven design tools, visit the following Web sites at:

Products		Design Support	
Amplifiers	<a href="http://www.national.com/amplifiers">www.national.com/amplifiers</a>	WEBENCH® Tools	<a href="http://www.national.com/webench">www.national.com/webench</a>
Audio	<a href="http://www.national.com/audio">www.national.com/audio</a>	App Notes	<a href="http://www.national.com/appnotes">www.national.com/appnotes</a>
Clock and Timing	<a href="http://www.national.com/timing">www.national.com/timing</a>	Reference Designs	<a href="http://www.national.com/refdesigns">www.national.com/refdesigns</a>
Data Converters	<a href="http://www.national.com/adc">www.national.com/adc</a>	Samples	<a href="http://www.national.com/samples">www.national.com/samples</a>
Interface	<a href="http://www.national.com/interface">www.national.com/interface</a>	Eval Boards	<a href="http://www.national.com/evalboards">www.national.com/evalboards</a>
LVDS	<a href="http://www.national.com/lvds">www.national.com/lvds</a>	Packaging	<a href="http://www.national.com/packaging">www.national.com/packaging</a>
Power Management	<a href="http://www.national.com/power">www.national.com/power</a>	Green Compliance	<a href="http://www.national.com/quality/green">www.national.com/quality/green</a>
Switching Regulators	<a href="http://www.national.com/switchers">www.national.com/switchers</a>	Distributors	<a href="http://www.national.com/contacts">www.national.com/contacts</a>
LDOs	<a href="http://www.national.com/ldo">www.national.com/ldo</a>	Quality and Reliability	<a href="http://www.national.com/quality">www.national.com/quality</a>
LED Lighting	<a href="http://www.national.com/led">www.national.com/led</a>	Feedback/Support	<a href="http://www.national.com/feedback">www.national.com/feedback</a>
Voltage Reference	<a href="http://www.national.com/vref">www.national.com/vref</a>	Design Made Easy	<a href="http://www.national.com/easy">www.national.com/easy</a>
PowerWise® Solutions	<a href="http://www.national.com/powerwise">www.national.com/powerwise</a>	Solutions	<a href="http://www.national.com/solutions">www.national.com/solutions</a>
Serial Digital Interface (SDI)	<a href="http://www.national.com/sdi">www.national.com/sdi</a>	Mil/Aero	<a href="http://www.national.com/milaero">www.national.com/milaero</a>
Temperature Sensors	<a href="http://www.national.com/tempensors">www.national.com/tempensors</a>	SolarMagic™	<a href="http://www.national.com/solarmagic">www.national.com/solarmagic</a>
Wireless (PLL/VCO)	<a href="http://www.national.com/wireless">www.national.com/wireless</a>	PowerWise® Design University	<a href="http://www.national.com/training">www.national.com/training</a>

THE CONTENTS OF THIS DOCUMENT ARE PROVIDED IN CONNECTION WITH NATIONAL SEMICONDUCTOR CORPORATION ("NATIONAL") PRODUCTS. NATIONAL MAKES NO REPRESENTATIONS OR WARRANTIES WITH RESPECT TO THE ACCURACY OR COMPLETENESS OF THE CONTENTS OF THIS PUBLICATION AND RESERVES THE RIGHT TO MAKE CHANGES TO SPECIFICATIONS AND PRODUCT DESCRIPTIONS AT ANY TIME WITHOUT NOTICE. NO LICENSE, WHETHER EXPRESS, IMPLIED, ARISING BY ESTOPPEL OR OTHERWISE, TO ANY INTELLECTUAL PROPERTY RIGHTS IS GRANTED BY THIS DOCUMENT.

TESTING AND OTHER QUALITY CONTROLS ARE USED TO THE EXTENT NATIONAL DEEMS NECESSARY TO SUPPORT NATIONAL'S PRODUCT WARRANTY. EXCEPT WHERE MANDATED BY GOVERNMENT REQUIREMENTS, TESTING OF ALL PARAMETERS OF EACH PRODUCT IS NOT NECESSARILY PERFORMED. NATIONAL ASSUMES NO LIABILITY FOR APPLICATIONS ASSISTANCE OR BUYER PRODUCT DESIGN. BUYERS ARE RESPONSIBLE FOR THEIR PRODUCTS AND APPLICATIONS USING NATIONAL COMPONENTS. PRIOR TO USING OR DISTRIBUTING ANY PRODUCTS THAT INCLUDE NATIONAL COMPONENTS, BUYERS SHOULD PROVIDE ADEQUATE DESIGN, TESTING AND OPERATING SAFEGUARDS.

EXCEPT AS PROVIDED IN NATIONAL'S TERMS AND CONDITIONS OF SALE FOR SUCH PRODUCTS, NATIONAL ASSUMES NO LIABILITY WHATSOEVER, AND NATIONAL DISCLAIMS ANY EXPRESS OR IMPLIED WARRANTY RELATING TO THE SALE AND/OR USE OF NATIONAL PRODUCTS INCLUDING LIABILITY OR WARRANTIES RELATING TO FITNESS FOR A PARTICULAR PURPOSE, MERCHANTABILITY, OR INFRINGEMENT OF ANY PATENT, COPYRIGHT OR OTHER INTELLECTUAL PROPERTY RIGHT.

#### LIFE SUPPORT POLICY

**NATIONAL'S PRODUCTS ARE NOT AUTHORIZED FOR USE AS CRITICAL COMPONENTS IN LIFE SUPPORT DEVICES OR SYSTEMS WITHOUT THE EXPRESS PRIOR WRITTEN APPROVAL OF THE CHIEF EXECUTIVE OFFICER AND GENERAL COUNSEL OF NATIONAL SEMICONDUCTOR CORPORATION.** As used herein:

Life support devices or systems are devices which (a) are intended for surgical implant into the body, or (b) support or sustain life and whose failure to perform when properly used in accordance with instructions for use provided in the labeling can be reasonably expected to result in a significant injury to the user. A critical component is any component in a life support device or system whose failure to perform can be reasonably expected to cause the failure of the life support device or system or to affect its safety or effectiveness.

National Semiconductor and the National Semiconductor logo are registered trademarks of National Semiconductor Corporation. All other brand or product names may be trademarks or registered trademarks of their respective holders.

Copyright© 2009 National Semiconductor Corporation

For the most current product information visit us at [www.national.com](http://www.national.com)



**National Semiconductor  
Americas Technical  
Support Center**  
Email: [support@nsc.com](mailto:support@nsc.com)  
Tel: 1-800-272-9959

**National Semiconductor Europe  
Technical Support Center**  
Email: [europe.support@nsc.com](mailto:europe.support@nsc.com)

**National Semiconductor Asia  
Pacific Technical Support Center**  
Email: [ap.support@nsc.com](mailto:ap.support@nsc.com)

**National Semiconductor Japan  
Technical Support Center**  
Email: [jpn.feedback@nsc.com](mailto:jpn.feedback@nsc.com)