

# Ultra-Efficient Charge Pumps for Six White/RGB LEDs in 3mm x 3mm Thin QFN

## General Description

The MAX8647/MAX8648 drive up to six white LEDs or two sets of RGB LEDs with regulated constant current for display backlight and fun light applications. By utilizing an inverting charge pump and extremely low-dropout adaptive current regulators, these ICs achieve very high efficiency over the full 1-cell Li+ battery voltage range and even with large LED forward voltage mismatch. The 1MHz fixed-frequency switching allows for tiny external components. The regulation scheme is optimized to ensure low EMI and low input ripple. The MAX8647/MAX8648 include thermal shutdown, open- and short-circuit protection.

The MAX8647 features an I<sup>2</sup>C serial port, while the MAX8648 features a three-wire serial-pulse logic interface. Both devices support independent on/off and dimming for main and subbacklights. The dimming ranges are pseudo-logarithmic from 24mA to 0.1mA and off in 32 steps. Both devices include a temperature derating function to safely allow bright 24mA full-scale output current setting while automatically reducing current to protect LEDs at high ambient temperatures above +60°C.

The MAX8647/MAX8648 are available in a 16-pin, 3mm x 3mm thin QFN package (0.8mm max height).

## Applications

White LED Backlighting, Single or Dual Display  
Wide-Gamut RGB LED Display Backlighting  
Camera Flash or RGB Indicators  
Cellular Phones and Smartphones  
PDAs, Digital Cameras, and Camcorders

## Pin Configuration

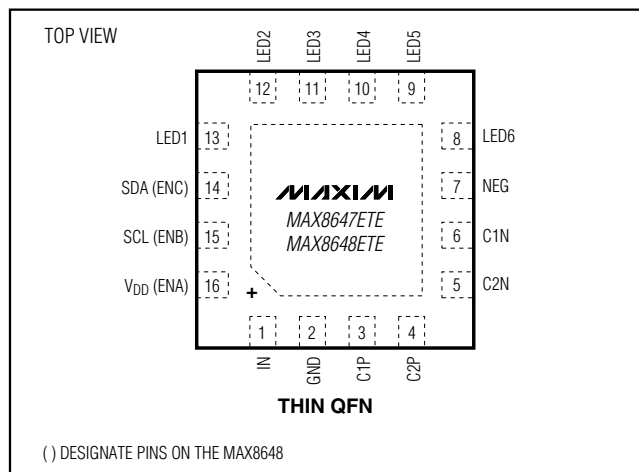

## Features

- ◆ Six Adaptive Current Regulators
- ◆ Independent Voltage Supply for Each LED
- ◆ Individual LED Brightness Control (MAX8647)
- ◆ 24mA to 0.1mA Dimming Range I<sup>2</sup>C Interface (MAX8647)  
Serial-Pulse Dimming Logic (MAX8648)
- ◆ ±2% Accuracy, ±0.4% Matching (typ)
- ◆ Low 70µA Quiescent Current
- ◆ Low 1µA Shutdown Current
- ◆ Inrush Current Limit
- ◆ T<sub>A</sub> Derating Function Protects LEDs
- ◆ 16-Pin, 3mm x 3mm Thin QFN Package

## Ordering Information

PART	DIMMING	PIN PACKAGE	TOP MARK	PKG CODE
MAX8647ETE+	I <sup>2</sup> C interface	16 Thin QFN-EP*	AFD	T1633-5
MAX8648ETE+	Serial-pulse logic	16 Thin QFN-EP*	AFE	T1633-5

**Note:** All devices are specified over the -40°C to +85°C extended temperature range.

+ Denotes a lead-free package.

\* EP = Exposed paddle.

## Typical Operating Circuit

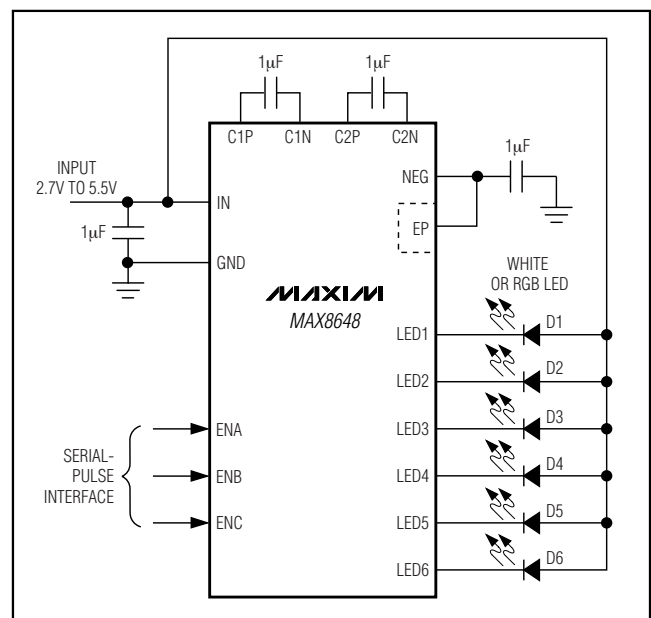

# Ultra-Efficient Charge Pumps for Six White/RGB LEDs in 3mm x 3mm Thin QFN

## ABSOLUTE MAXIMUM RATINGS

V<sub>DD</sub>, IN, SCL, SDA, ENA, ENB, ENC to GND.....-0.3V to +6.0V  
 V<sub>DD</sub>, IN, SCL, SDA, ENA, ENB, ENC to NEG.....-0.3V to +6.0V  
 NEG to GND .....-6V to +0.3V  
 C2N to GND .....-6V to +0.3V  
 C1P, C2P to GND .....-0.3V to (V<sub>IN</sub> + 0.3V)  
 C2P to C1N.....-0.3V to (V<sub>IN</sub> + 0.3V)  
 LED<sub>-</sub>, C1N, C2N to NEG .....-0.3V to (V<sub>IN</sub> + 0.3V)

Continuous Power Dissipation (T<sub>A</sub> = +70°C)  
 16-Pin Thin QFN 3mm x 3mm (derate 20.8mW/°C  
 above +70°C).....1667mW  
 Junction Temperature .....+150°C  
 Storage Temperature Range .....-65°C to +150°C  
 Lead Temperature (soldering, 10s) .....+300°C

Stresses beyond those listed under "Absolute Maximum Ratings" may cause permanent damage to the device. These are stress ratings only, and functional operation of the device at these or any other conditions beyond those indicated in the operational sections of the specifications is not implied. Exposure to absolute maximum rating conditions for extended periods may affect device reliability.

## ELECTRICAL CHARACTERISTICS

(V<sub>VDD</sub> = V<sub>IN</sub> = 3.6V, V<sub>GND</sub> = 0V, T<sub>A</sub> = -40°C to +85°C, unless otherwise noted. Typical values are at T<sub>A</sub> = +25°C.) (Note 1)

PARAMETER	CONDITIONS	MIN	TYP	MAX	UNITS
IN Operating Voltage		2.7		5.5	V
V <sub>DD</sub> Operating Voltage		1.7		5.5	V
Undervoltage-Lockout (UVLO) Threshold	V <sub>IN</sub> rising	2.35	2.45	2.55	V
Undervoltage-Lockout Hysteresis			100		mV
IN Shutdown Supply Current (All Outputs Off)	V <sub>SCL</sub> = V <sub>SDA</sub> = V <sub>DD</sub> (MAX8647), V <sub>EN<sub>-</sub></sub> = 0V (MAX8648)		T <sub>A</sub> = +25°C 0.4 T <sub>A</sub> = +85°C 0.4	2.5	μA
V <sub>DD</sub> Shutdown Supply Current	T <sub>A</sub> = +25°C T <sub>A</sub> = +85°C		0.1 0.1	1.0	μA
IN Operating Supply Current	Charge pump inactive, two LEDs enabled at 0.1mA setting		70	100	μA
	Charge pump active, 1MHz switching, all LEDs enabled at 0.1mA setting		1.6		mA
V <sub>DD</sub> Operating Supply Current	Charge pump inactive, two LEDs enabled at 0.1mA setting, T <sub>A</sub> = +25°C Charge pump active, 1MHz switching, all LEDs enabled at 0.1mA setting, T <sub>A</sub> = +85°C		0.1 0.1	1.0	μA
Thermal-Shutdown Threshold			+160		°C
Thermal-Shutdown Hysteresis			20		°C
<b>I<sup>2</sup>C INTERFACE (MAX8647)</b>					
Logic-Input High Voltage (SDA, SCL)	V <sub>DD</sub> = 1.7V to 5.5V, hysteresis = 0.2 x V <sub>DD</sub> (typ)	0.7 x V <sub>DD</sub>			V
Logic-Input Low Voltage (SDA, SCL)	V <sub>DD</sub> = 1.7V to 5.5V, hysteresis = 0.2 x V <sub>DD</sub> (typ)			0.3 x V <sub>DD</sub>	V
Filtered Pulse Width (t <sub>SP</sub> )	V <sub>IN</sub> = 2.7V to 5.5V, V <sub>DD</sub> = 1.7V to 5.5V (Note 2)			50	ns
Logic-Input Current (SDA, SCL)	V <sub>IL</sub> = 0V or V <sub>IH</sub> = 5.5V		T <sub>A</sub> = +25°C -1 T <sub>A</sub> = +85°C 0.1	+1	μA

# Ultra-Efficient Charge Pumps for Six White/RGB LEDs in 3mm x 3mm Thin QFN

MAX8647/MAX8648

## ELECTRICAL CHARACTERISTICS (continued)

( $V_{DD} = V_{IN} = 3.6V$ ,  $V_{GND} = 0V$ ,  $T_A = -40^{\circ}C$  to  $+85^{\circ}C$ , unless otherwise noted. Typical values are at  $T_A = +25^{\circ}C$ .) (Note 1)

PARAMETER	CONDITIONS	MIN	TYP	MAX	UNITS	
SDA Output Low Voltage	$I_{SDA} = 3mA$ , for acknowledge (Note 2)		0.03	0.40	V	
I <sup>2</sup> C Clock Frequency				400	kHz	
Bus Free Time Between START and STOP ( $t_{BUF}$ )	(Note 2)	1.3			$\mu s$	
Hold Time Repeated START Condition ( $t_{HD\_STA}$ )	(Note 2)	0.6	0.1		$\mu s$	
SCL Low Period ( $t_{LOW}$ )	(Note 2)	1.3	0.2		$\mu s$	
SCL High Period ( $t_{HIGH}$ )	(Note 2)	0.6	0.2		$\mu s$	
Setup Time Repeated START Condition ( $t_{SU\_STA}$ )	(Note 2)	0.6	0.1		$\mu s$	
SDA Hold Time ( $t_{HD\_DAT}$ )	(Note 2)	0	-0.01		$\mu s$	
SDA Setup Time ( $t_{SU\_DAT}$ )	(Note 2)	100	50		ns	
Setup Time for STOP Condition ( $t_{SU\_STO}$ )	(Note 2)	0.6	0.1		$\mu s$	
<b>SERIAL-PULSE LOGIC (EN_) (MAX8648)</b>						
Logic-Input High Voltage	$V_{IN} = 2.7V$ to $5.5V$	1.4			V	
Logic-Input Low Voltage	$V_{IN} = 2.7V$ to $5.5V$			0.4	V	
Logic-Input Current	$V_{IL} = 0V$ or $V_{IH} = 5.5V$	$T_A = +25^{\circ}C$	-1	0.01	+1	$\mu A$
		$T_A = +85^{\circ}C$		0.1		
EN Low Shutdown Delay $t_{SHDN}$	See Figure 3 and the <i>Shutdown Mode</i> section; EN <sub>+</sub> needs to be longer than 4ms to ensure LED is powered off	4			ms	
$t_{LO}$ (Figure 3)		1		500	$\mu s$	
$t_{HI}$ (Figure 3)		1			$\mu s$	
Initial $t_{HI}$ (Figure 3)	First EN <sub>+</sub> high pulse	120			$\mu s$	
<b>CHARGE PUMP</b>						
Switching Frequency			1		MHz	
Soft-Start Time			0.5		ms	
Charge-Pump Regulation Voltage	$(V_{IN} - V_{NEG})$	4.3	5.0		V	
Open-Loop NEG Output Resistance	$(V_{NEG} - 0.5 \times V_{IN}) / I_{NEG}$		2.5	5	$\Omega$	
NEG Discharge Resistance in Shutdown or When the Charge Pump is Inactive	All LEDs off, EN <sub>+</sub> = GND		10		k $\Omega$	
<b>LED1-LED6 CURRENT REGULATOR</b>						
Current Setting Range	Through an I <sup>2</sup> C or serial-pulse interface	0.1		24.0	mA	
Current Accuracy	$V_{LED\_+} = 0.5V$ for charge-pump inactive, $V_{LED\_+} = -0.9V$ , $V_{NEG\_+} = -1.4V$	24mA setting, $T_A = +25^{\circ}C$	-2	$\pm 1$	+2	%
		24mA setting, $T_A = -40^{\circ}C$ to derating function start temperature (Note 2)	-5		+5	
		1.6mA setting, $T_A = +25^{\circ}C$	-15	$\pm 5$	+15	

# Ultra-Efficient Charge Pumps for Six White/RGB LEDs in 3mm x 3mm Thin QFN

## ELECTRICAL CHARACTERISTICS (continued)

( $V_{DD} = V_{IN} = 3.6V$ ,  $V_{GND} = 0V$ ,  $T_A = -40^{\circ}C$  to  $+85^{\circ}C$ , unless otherwise noted. Typical values are at  $T_A = +25^{\circ}C$ .) (Note 1)

PARAMETER	CONDITIONS		MIN	TYP	MAX	UNITS
Derating-Function Start Temperature				+60		$^{\circ}C$
Derating-Function Slope	From derating-function start temperature			-2.5		$\%/^{\circ}C$
LED_ R <sub>DSON</sub>	Not utilizing the charge pump			3		$\Omega$
	Utilizing the charge pump			4		
LED_ Dropout	24mA setting (Note 3)	Not utilizing the charge pump		60	120	mV
		Utilizing the charge pump		90	200	
LED_ Current Regulator Switchover Threshold (Inactive to Active)	V <sub>LED_</sub> falling		125	150	175	mV
LED_ Current Regulator Switchover Hysteresis				100		mV
LED_ Leakage in Shutdown	All LEDs off	$T_A = +25^{\circ}C$		0.01	5	$\mu A$
		$T_A = +85^{\circ}C$		0.1		

**Note 1:** Limits are 100% production tested at  $T_A = +25^{\circ}C$ . Specifications over the operating temperature range are guaranteed by design.

**Note 2:** Guaranteed by design.

**Note 3:** LED dropout voltage is defined as the LED\_ to GND voltage at which current into LED\_ drops 10% from the value at  $V_{LED_} = 0.5V$ .

## Typical Operating Characteristics

( $V_{IN} = 3.6V$ ,  $V_{EN_} = V_{IN}$ , circuit of Figure 1,  $T_A = +25^{\circ}C$ , unless otherwise noted.)

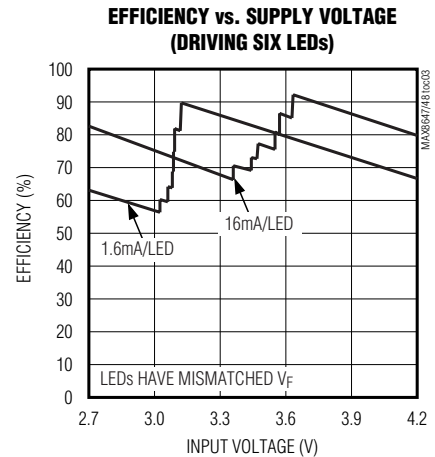
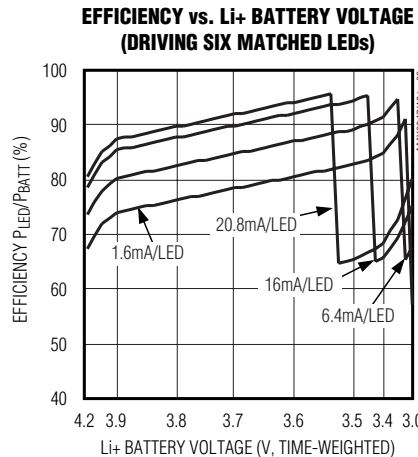
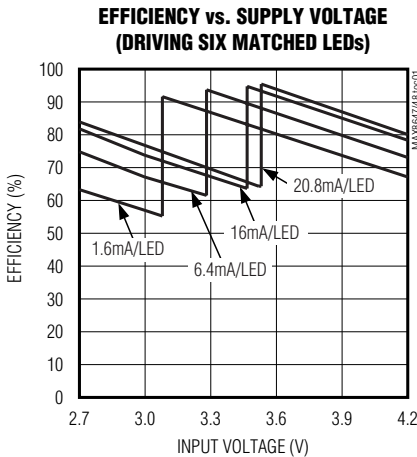

# Ultra-Efficient Charge Pumps for Six White/RGB LEDs in 3mm x 3mm Thin QFN

## Typical Operating Characteristics (continued)

( $V_{IN} = 3.6V$ ,  $V_{EN-} = V_{IN}$ , circuit of Figure 1,  $T_A = +25^{\circ}C$ , unless otherwise noted.)

MAX8647/MAX8648

**EFFICIENCY vs. SUPPLY VOLTAGE (DRIVING SIX LEDs)**

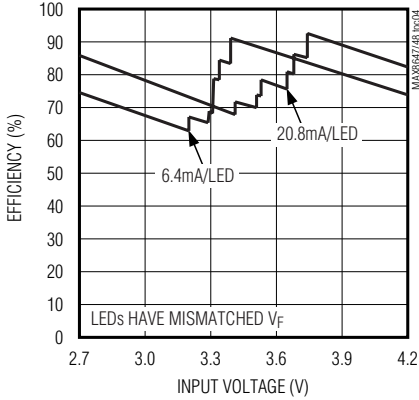

**EFFICIENCY vs. Li+ BATTERY VOLTAGE (DRIVING SIX LEDs)**

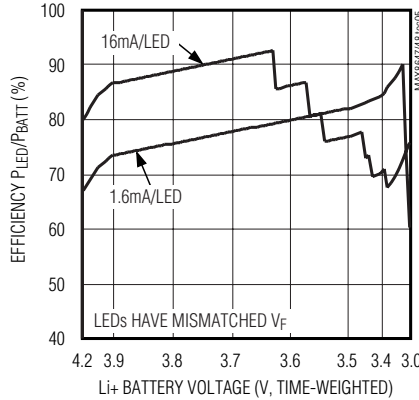

**EFFICIENCY vs. Li+ BATTERY VOLTAGE (DRIVING SIX LEDs)**

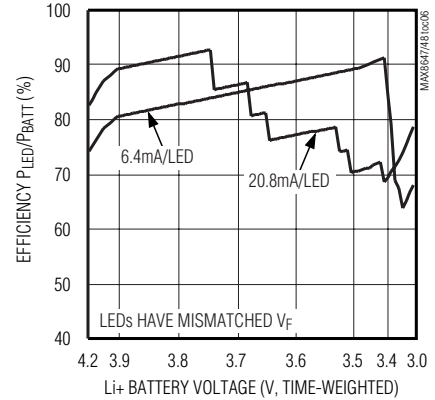

**INPUT CURRENT vs. INPUT VOLTAGE (DRIVING SIX LEDs)**

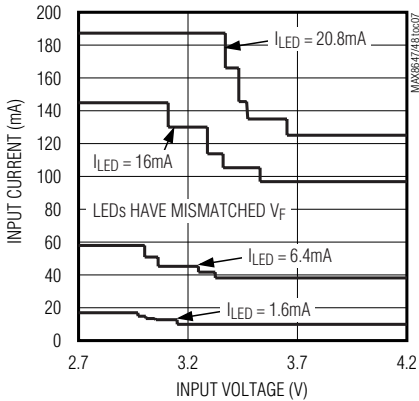

**INPUT CURRENT vs. Li+ BATTERY VOLTAGE (DRIVING SIX LEDs)**

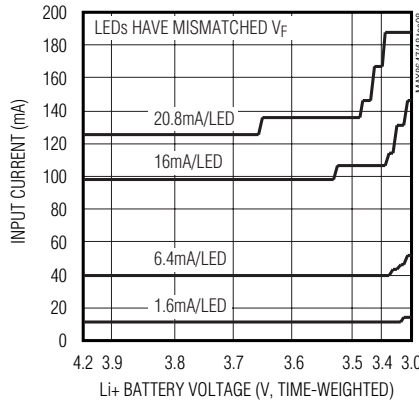

**INPUT CURRENT vs. INPUT VOLTAGE (RGB MODULE)**

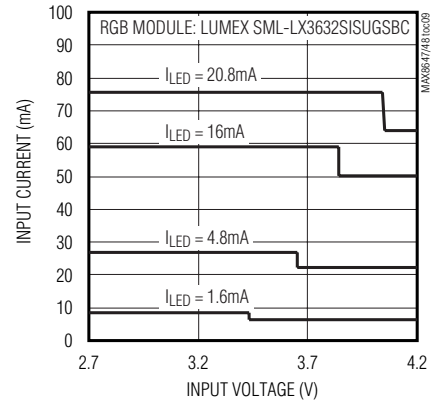

**INPUT CURRENT vs. Li+ BATTERY VOLTAGE (RGB MODULE)**

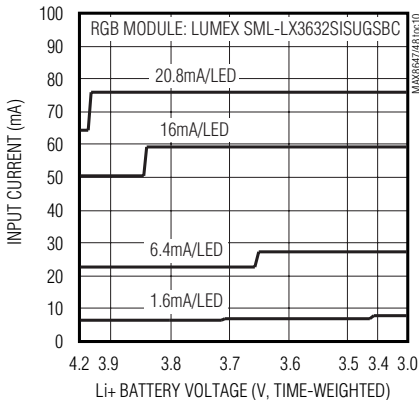

**INPUT RIPPLE VOLTAGE vs. SUPPLY VOLTAGE (DRIVING SIX WHITE LEDs)**

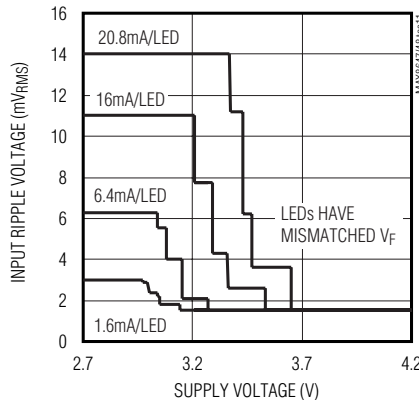

**LED CURRENT MATCHING vs. INPUT VOLTAGE (16mA/LED)**

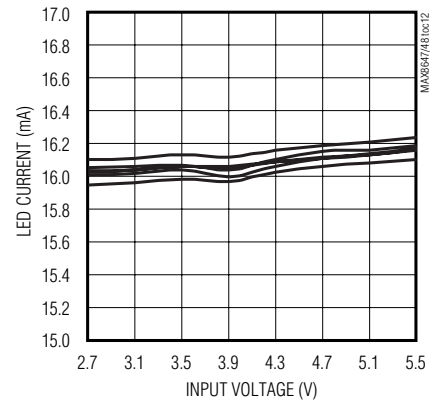

# Ultra-Efficient Charge Pumps for Six White/RGB LEDs in 3mm x 3mm Thin QFN

## Typical Operating Characteristics (continued)

( $V_{IN} = 3.6V$ ,  $V_{EN\_} = V_{IN}$ , circuit of Figure 1,  $T_A = +25^\circ C$ , unless otherwise noted.)

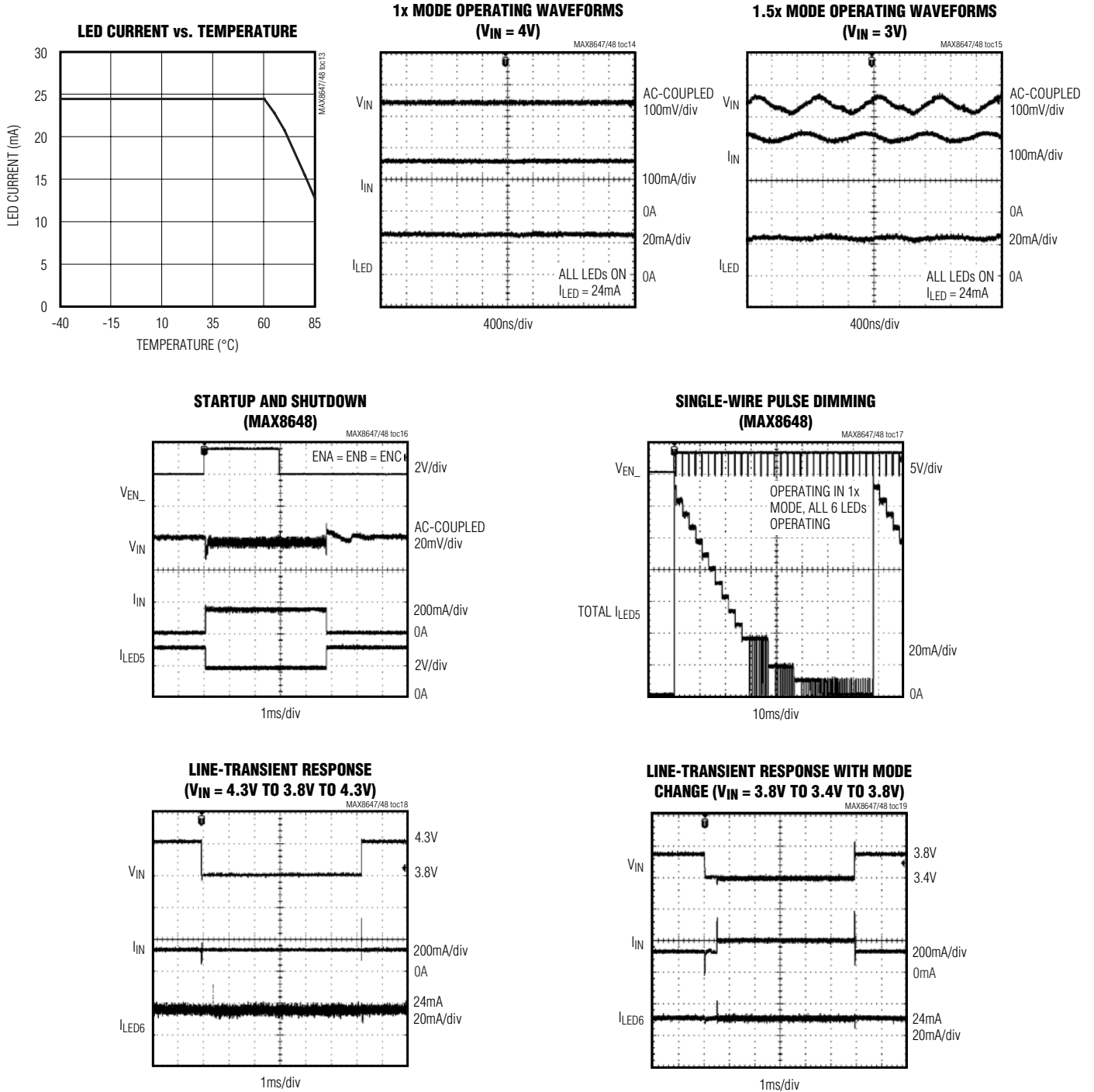

# Ultra-Efficient Charge Pumps for Six White/RGB LEDs in 3mm x 3mm Thin QFN

## Pin Description

MAX8647/MAX8648

PIN		NAME	FUNCTION
MAX8647	MAX8648		
1	1	IN	Supply Voltage Input. The input voltage range is 2.7V to 5.5V. Bypass IN to GND with a 1µF ceramic capacitor as close as possible to the IC. IN is high impedance during shutdown. Connect IN to the anodes of all the LEDs.
2	2	GND	Ground. Connect GND to system ground and the input bypass capacitor as close as possible to the IC.
3	3	C1P	Transfer Capacitor 1 Positive Connection. Connect a 1µF ceramic capacitor from C1P to C1N.
4	4	C2P	Transfer Capacitor 2 Positive Connection. Connect a 1µF ceramic capacitor from C2P to C2N.
5	5	C2N	Transfer Capacitor 2 Negative Connection. Connect a 1µF ceramic capacitor from C2P to C2N. An internal 10kΩ resistor pulls C2N to GND during shutdown.
6	6	C1N	Transfer Capacitor 1 Negative Connection. Connect a 1µF ceramic capacitor from C1P to C1N.
7	7	NEG	Charge-Pump Negative Output. Connect a 1µF ceramic capacitor from NEG to GND. In shutdown, an internal 10kΩ resistor pulls NEG to GND. Connect the exposed paddle to NEG directly under the IC.
8–13	8–13	LED6–LED1	LED Current Regulators. Current flowing into LED_ is based on the internal registers. Connect LED_ to the cathodes of the external LEDs. LED_ is high impedance during shutdown. For the MAX8647, program any unused LED_ to off and LED_ can be shorted to ground or left unconnected. For the MAX8648, short any unused LED_ to IN prior to power-up to disable the corresponding current regulator.
14	—	SDA	I <sup>2</sup> C Data Input. Data is read on the rising edge of SCL.
15	—	SCL	I <sup>2</sup> C Clock Input. Data is read on the rising edge of SCL.
16	—	V <sub>DD</sub>	Logic-Input Supply Voltage. Connect to the supply voltage driving SDA and SCL. Bypass V <sub>DD</sub> to GND with a 0.1µF ceramic capacitor.
—	14, 15, 16	ENC, ENB, ENA	Enable and Serial-Pulse Dimming Control. ENA controls LED1, LED2, and LED3. ENB controls LED4 and LED5. ENC controls LED6. Drive EN_ logic-high to turn on the IC and enable the corresponding LED_ at 24mA each. Drive an individual EN_ logic-low for greater than 4ms to turn off the corresponding-current regulators or drive all three EN_ low to place the IC in shutdown. See the <i>Serial-Pulse Dimming Control (MAX8648)</i> section.
—	—	EP	Exposed Paddle. Connect to NEG.

# Ultra-Efficient Charge Pumps for Six White/RGB LEDs in 3mm x 3mm Thin QFN

## Detailed Description

The MAX8647/MAX8648 have an inverting charge pump and six current regulators capable of 24mA each to drive six white LEDs or two sets of RGB LEDs. The current regulators are matched to within  $\pm 0.4\%$  (typ) providing uniform white LED brightness for LCD backlight applications. To maximize efficiency, the current regulators operate with as little as 0.15V voltage drop.

Individual white LED current regulators conduct current to GND or NEG to extend usable battery life. In the case of mismatched forward voltage of white LEDs, only the white LEDs requiring higher voltage are switched to pull current to NEG instead of GND, further raising efficiency and reducing battery current drain.

### Current-Regulator Switchover

When  $V_{IN}$  is higher than the forward voltage of the white LED plus the 0.15V headroom of the current regulator, the LED current returns through GND. If this condition is satisfied for all six white LEDs, the charge pump remains inactive. When the input voltage drops so that the current-regulator headroom cannot be maintained for any of the individual white LEDs, the inverting charge pump activates and generates a voltage on the NEG pin that is no greater than 5V below  $V_{IN}$ . Each current regulator contains circuitry that detects when it is in dropout and switches that current-regulator return path from GND to NEG. Since this is done on an LED-by-LED basis, the LED current is switched for only the individual LED requiring higher voltage, thus minimizing power consumption.

### Low LED Current Levels

The MAX8647/MAX8648 internally generate a PWM signal to obtain higher resolution at lower currents. See Single-Wire Pulse Dimming in the *Typical Operating Characteristics* section. As the  $I_{LED}$  setting is below 6.4mA, the IC adjusts not only  $I_{LED}$  DC current, but the duty cycle is controlled by the PWM signal. The frequency of the PWM dimming signal is set at 1kHz with a minimum duty cycle of 1/16 to avoid the LED flicking effect to human eyes. Table 1 shows the current level and the corresponding duty cycle.

### I<sup>2</sup>C Interface (MAX8647)

An I<sup>2</sup>C 2-wire serial interface is provided on the MAX8647 to control the LEDs. The serial interface consists of a serial-data line (SDA) and a serial-clock line (SCL). Standard I<sup>2</sup>C write-byte commands are

used. Figure 2 shows a timing diagram for the I<sup>2</sup>C protocol. The MAX8647 is a slave-only device, relying upon a master to generate a clock signal. The master (typically a microprocessor) initiates data transfer on the bus and generates SCL to permit data transfer. A master device communicates with the MAX8647 by transmitting the proper 8-bit address (0x9A) followed by the 8-bit control byte. Each 8-bit control byte consists of a 3-bit command code and 5 bits of data (Table 1). Each transmit sequence is framed by a START (A) condition and a STOP (L) condition (Figure 2). Each word transmitted over the bus is 8 bits long and is always followed by an ACKNOWLEDGE CLOCK PULSE (K). The power-on default settings for D4 to D0 are all 0, which indicates that all LED\_ are off.

### Serial-Pulse Dimming Control (MAX8648)

When the LEDs are enabled by driving EN\_ high, the MAX8648 ramps LED current to 24mA. Dim the LEDs by pulsing EN\_ low (1 $\mu$ s to 500 $\mu$ s pulse width). Each pulse reduces the LED current based on the LED dimming table, Table 3. After the current reaches 0.1mA, the next pulse restores the current to 24mA. Figure 3 shows a timing diagram for EN\_. ENA controls LED1, LED2, and LED3. ENB controls LED4 and LED5. ENC controls LED6.

If dimming control is not required, EN\_ work as simple 100% brightness or off controls. Drive EN\_ high to enable the LEDs, or drive EN\_ low to disable. The IC is shut-down when all three EN\_ are low for 4ms or longer.

**Table 1. Internal PWM Duty Cycle vs. LED Set Current**

$I_{LED}$ (mA)	DUTY CYCLE (n/16)	$I_{LED}$ (mA)	DUTY CYCLE (n/16)
6.4	16	1.2	12
5.6	14	1.0	10
4.8	12	0.8	8
4.0	10	0.7	7
3.2	16	0.6	6
2.8	14	0.5	5
2.4	12	0.4	4
2.0	10	0.3	3
1.6	16	0.2	2
1.4	14	0.1	1



# Ultra-Efficient Charge Pumps for Six White/RGB LEDs in 3mm x 3mm Thin QFN

MAX8647/MAX8648

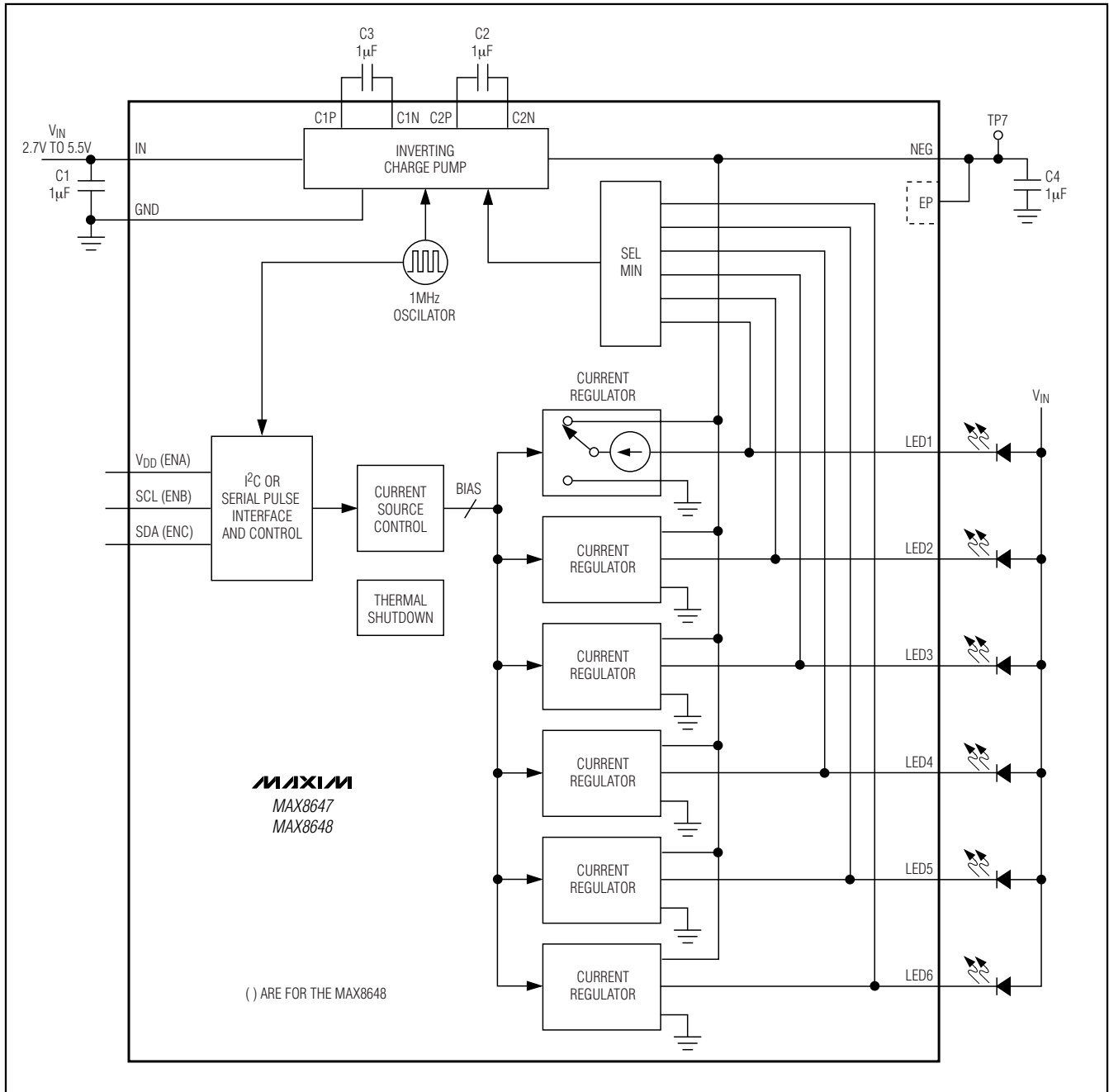

Figure 1. Block Diagram and Application Circuit

## Shutdown Mode

The MAX8647 is shutdown when all LEDs are turned off through the I<sup>2</sup>C port. In shutdown, the I<sup>2</sup>C port is still active and ready to receive a command.

The MAX8648 is shutdown when all three EN<sub>1</sub> are held low for 4ms or longer. In shutdown, NEG is pulled to GND with a 10kΩ internal resistor.

# Ultra-Efficient Charge Pumps for Six White/RGB LEDs in 3mm x 3mm Thin QFN

Table 2. I<sup>2</sup>C Control Data Byte—Device Address 0x9A

FUNCTION	SDA CONTROL BYTE							
	COMMAND			DATA				
	C2	C1	C0	D4	D3	D2	D1	D0
Not used	0	0	0	—	—	—	—	—
LED1 current	0	0	1	24.0mA to 0.1mA and off in 32 steps				
LED2 current	0	1	0	24.0mA to 0.1mA and off in 32 steps				
LED3 current	0	1	1	24.0mA to 0.1mA and off in 32 steps				
LED4 current	1	0	0	24.0mA to 0.1mA and off in 32 steps				
LED5 current	1	0	1	24.0mA to 0.1mA and off in 32 steps				
LED6 current	1	1	0	24.0mA to 0.1mA and off in 32 steps				
Not used	1	1	1	—	—	—	—	—

**Note:** C2 is MSB and D0 is LSB. The power-on default settings for D4 to D0 are all 0, which indicates that all LED\_ are off.

Table 3. MAX8647 I<sup>2</sup>C Data vs. LED Currents

D4	D3	D2	D1	D0	mA
1	1	1	1	1	24
1	1	1	1	0	22.4
1	1	1	0	1	20.8
1	1	1	0	0	19.2
1	1	0	1	1	17.6
1	1	0	1	0	16
1	1	0	0	1	14.4
1	1	0	0	0	12.8
1	0	1	1	1	11.2
1	0	1	1	0	9.6
1	0	1	0	1	8
1	0	1	0	0	6.4
1	0	0	1	1	5.6
1	0	0	1	0	4.8
1	0	0	0	1	4
1	0	0	0	0	3.2

D4	D3	D2	D1	D0	mA
0	1	1	1	1	2.8
0	1	1	1	0	2.4
0	1	1	0	1	2
0	1	1	0	0	1.6
0	1	0	1	1	1.4
0	1	0	1	0	1.2
0	1	0	0	1	1
0	1	0	0	0	0.8
0	0	1	1	1	0.7
0	0	1	1	0	0.6
0	0	1	0	1	0.5
0	0	1	0	0	0.4
0	0	0	1	1	0.3
0	0	0	1	0	0.2
0	0	0	0	1	0.1
0	0	0	0	0	OFF

### Temperature Derating Function

The MAX8647/MAX8648 contain a derating function that automatically limits the LED current at high temperatures to help protect the LEDs from damage. The derating function enables the safe usage of higher LED current at room temperature, thus reducing the number of LEDs required to backlight the display. The derating circuit lowers the LED current at approximately 2.5%/°C once the IC is above +60°C. The typical derating function characteristic is shown in the *Typical Operating Characteristics*.

### Power-Up LED Detection and Fault Protection

The MAX8648 contains special circuitry to detect short-circuit conditions at power-up and disable the corresponding current regulator to avoid wasting battery current. Connect any unused LED\_ to IN to disable the corresponding current regulator. If an LED fails short circuit, the current regulator continues the current regulated operation until power to the IC is cycled and the short circuit is detected. An open-circuit LED failure drives the voltage on the corresponding LED\_ output

# Ultra-Efficient Charge Pumps for Six White/RGB LEDs in 3mm x 3mm Thin QFN

MAX8647/MAX8648

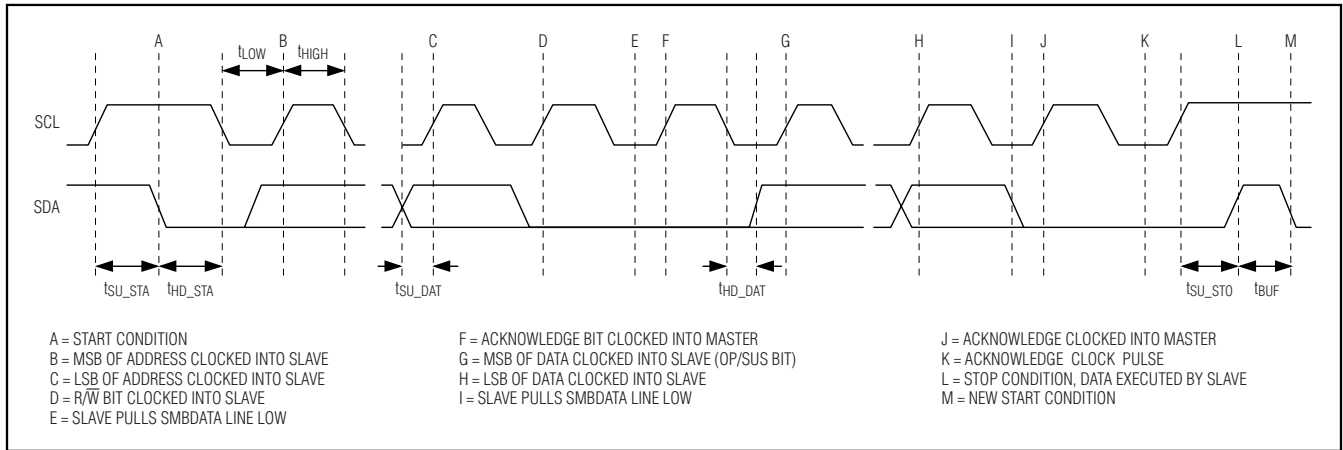

Figure 2. Definition of Timing for I<sup>2</sup>C Bus

Table 4. MAX8648 Pulse Dimming Step vs. LED Currents

mA	MAX8648 DIMMING STEPS
24.0	Startup or EN_ high
22.4	1
20.8	2
19.2	3
17.6	4
16.0	5
14.4	6
12.8	7
11.2	8
9.6	9
8.0	10
6.4	11
5.6	12
4.8	13
4.0	14
3.2	15

mA	MAX8648 DIMMING STEPS
2.8	16
2.4	17
2.0	18
1.6	19
1.4	20
1.2	21
1.0	22
0.8	23
0.7	24
0.6	25
0.5	26
0.4	27
0.3	28
0.2	29
0.1	30
24.0	31

below the switch over threshold enabling the inverting charge pump.

For the MAX8647, program any unused LED\_ to off using the I<sup>2</sup>C interface. Unused LED\_ can be connected to IN or left unconnected.

### Thermal Shutdown

The MAX8647/MAX8648 includes a thermal-limit circuit that shuts down the IC above about +160°C. The IC turns on after it cools by approximately 20°C.

## Applications Information

### Input Ripple

For LED drivers, input ripple is more important than output ripple. The amount of input ripple depends on the source supply's output impedance. Adding a lowpass filter to the input of the MAX8647/MAX8648 further reduces input ripple. Alternatively, increasing C<sub>IN</sub> to 2.2μF (or 4.7μF) cuts input ripple in half (or in fourth) with only a small increase in footprint.

# Ultra-Efficient Charge Pumps for Six White/RGB LEDs in 3mm x 3mm Thin QFN

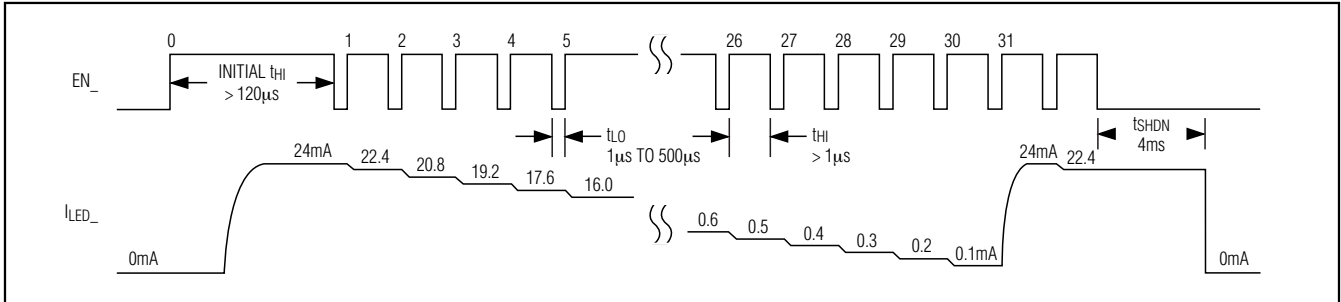

Figure 3. EN\_ Timing Diagram

### Capacitor Selection

Ceramic capacitors are recommended due to their small size, low cost, and low ESR. Select ceramic capacitors that maintain their capacitance over temperature and DC bias. Capacitors with X5R or X7R temperature characteristics generally perform well. Recommended values are shown in the *Typical Operating Circuit*. Using a larger value input capacitor helps to reduce input ripple (see the *Input Ripple* section).

### Driving LEDs with Multiple Supplies

It is not necessary for the LED anodes to connect to IN. Figure 7 shows an example using separate supplies to power the LED\_ groups of the MAX8648. In this example, the voltage source (V1) provides power for RGB LEDs (LED1, LED2, and LED3). V2 provides power for backlight LEDs (LED4 and LED5), and V3 provides power for a red charge indicator (LED6).

### PCB Layout and Routing

The MAX8647/MAX8648 have a high-frequency, switched-capacitor voltage inverter. For best circuit performance, use a solid copper plane and place C1–C4 as close as possible to the MAX8647/MAX8648. Figure 4 shows the MAX8648 evaluation kit example layout.

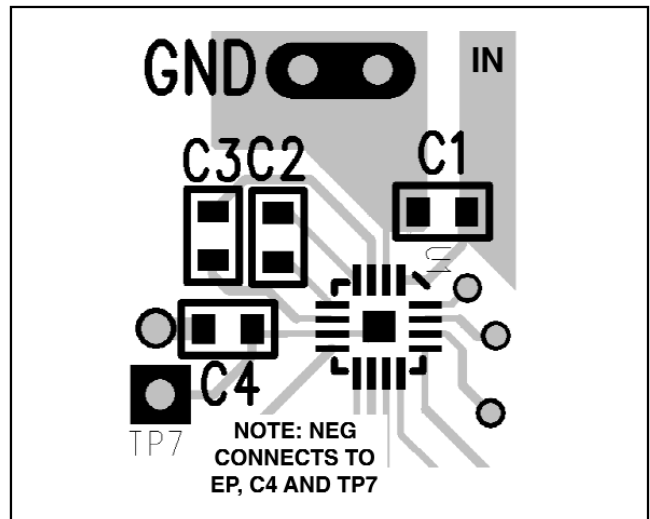

Figure 4. MAX8648 Evaluation Kit Layout for C1–C4

### Chip Information

PROCESS: BiCMOS

# Ultra-Efficient Charge Pumps for Six White/RGB LEDs in 3mm x 3mm Thin QFN

MAX8647/MAX8648

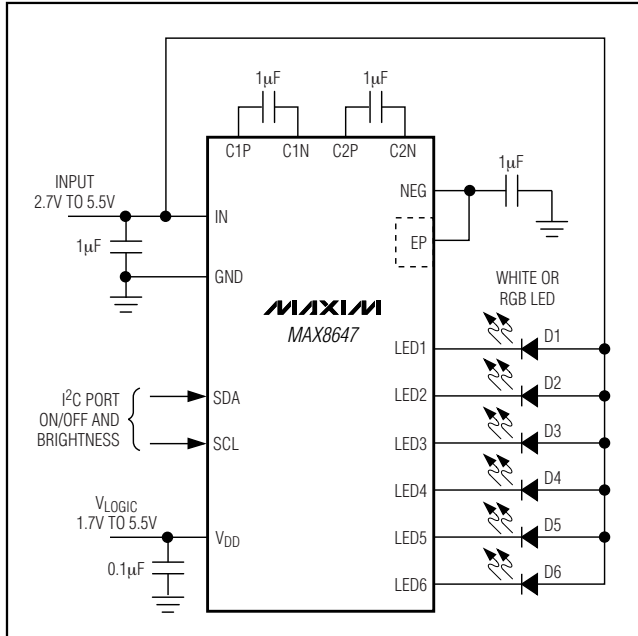

Figure 5. MAX8647 Typical Application Circuit

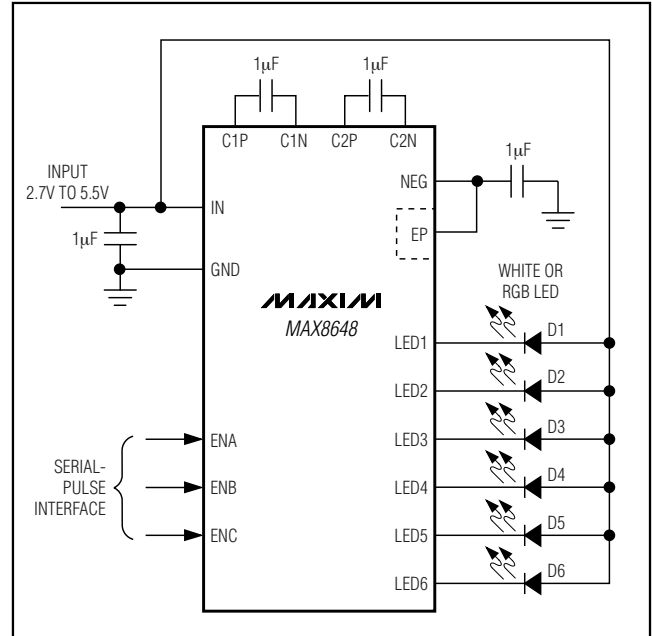

Figure 6. MAX8648 Typical Application Circuit

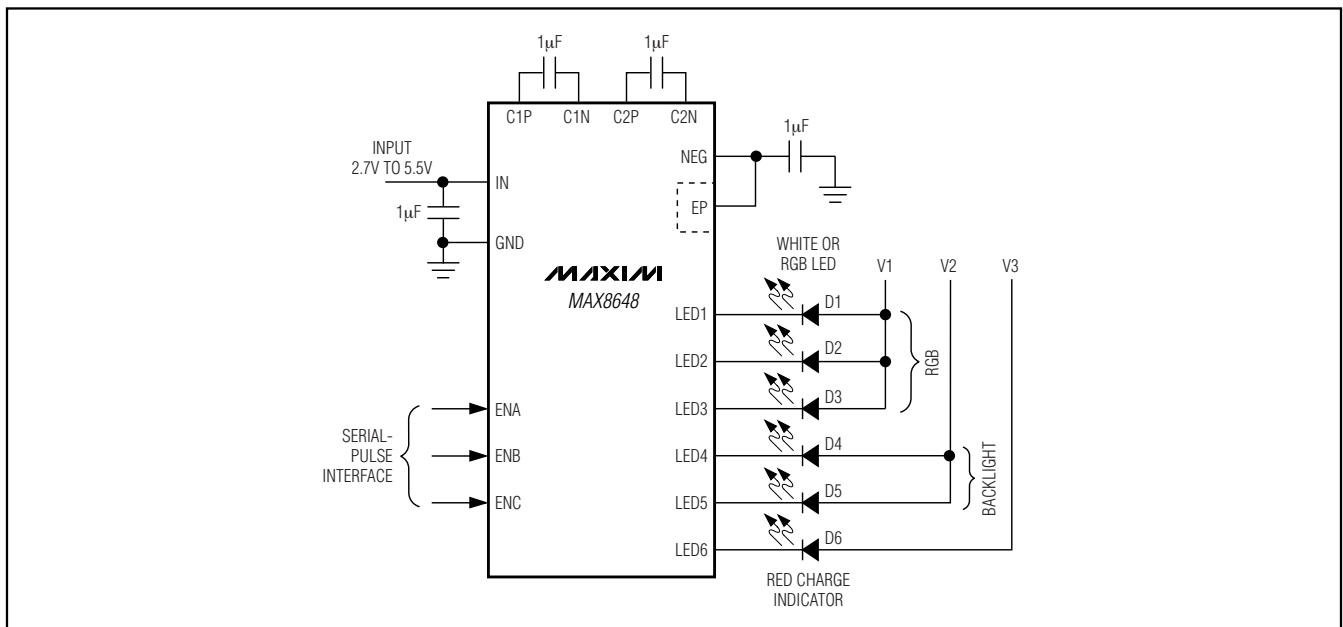
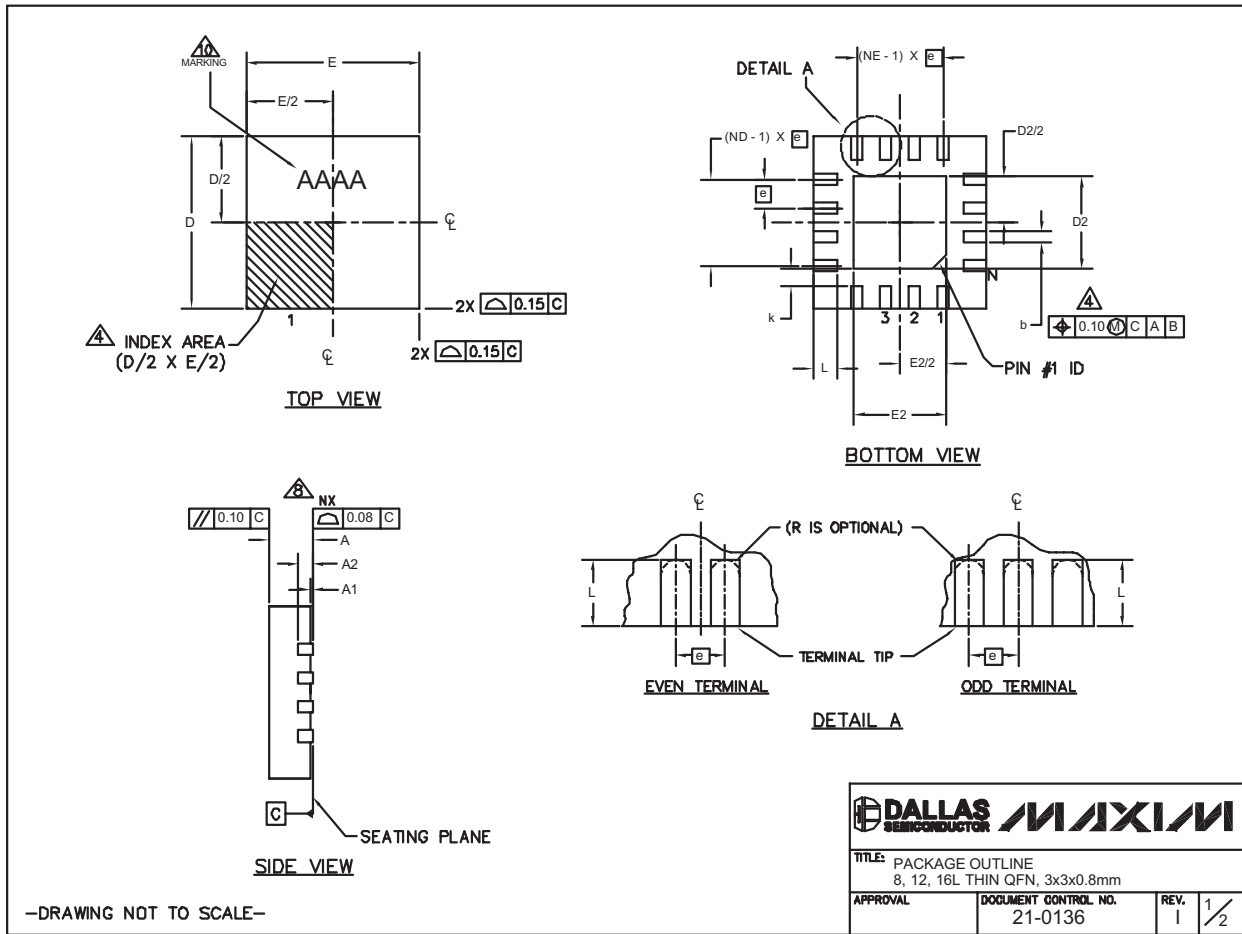

Figure 7. Driving LEDs with Multiple Supplies

# Ultra-Efficient Charge Pumps for Six White/RGB LEDs in 3mm x 3mm Thin QFN

## Package Information

(The package drawing(s) in this data sheet may not reflect the most current specifications. For the latest package outline information, go to [www.maxim-ic.com/packages](http://www.maxim-ic.com/packages).)



-DRAWING NOT TO SCALE-

<b>TITLE:</b> PACKAGE OUTLINE 8, 12, 16L THIN QFN, 3x3x0.8mm	
<b>APPROVAL</b>	<b>DOCUMENT CONTROL NO.</b> 21-0136
<b>REV.</b> I	1/2

# Ultra-Efficient Charge Pumps for Six White/RGB LEDs in 3mm x 3mm Thin QFN

## Package Information (continued)

(The package drawing(s) in this data sheet may not reflect the most current specifications. For the latest package outline information, go to [www.maxim-ic.com/packages](http://www.maxim-ic.com/packages).)

MAX8647/MAX8648

PKG REF.	8L 3x3			12L 3x3			16L 3x3		
	MIN.	NOM.	MAX.	MIN.	NOM.	MAX.	MIN.	NOM.	MAX.
A	0.70	0.75	0.80	0.70	0.75	0.80	0.70	0.75	0.80
b	0.25	0.30	0.35	0.20	0.25	0.30	0.20	0.25	0.30
D	2.90	3.00	3.10	2.90	3.00	3.10	2.90	3.00	3.10
E	2.90	3.00	3.10	2.90	3.00	3.10	2.90	3.00	3.10
e	0.65 BSC.			0.50 BSC.			0.50 BSC.		
L	0.35	0.55	0.75	0.45	0.55	0.65	0.30	0.40	0.50
N	8			12			16		
ND	2			3			4		
NE	2			3			4		
A1	0	0.02	0.05	0	0.02	0.05	0	0.02	0.05
A2	0.20 REF			0.20 REF			0.20 REF		
k	0.25	-	-	0.25	-	-	0.25	-	-

PKG CODES	EXPOSED PAD VARIATIONS						PIN ID	JEDEC
	D2			E2				
	MIN.	NOM.	MAX.	MIN.	NOM.	MAX.		
TQ833-1	0.25	0.70	1.25	0.25	0.70	1.25	0.35 x 45°	WEEC
T1233-1	0.95	1.10	1.25	0.95	1.10	1.25	0.35 x 45°	WEED-1
T1233-3	0.95	1.10	1.25	0.95	1.10	1.25	0.35 x 45°	WEED-1
T1233-4	0.95	1.10	1.25	0.95	1.10	1.25	0.35 x 45°	WEED-1
T1633-2	0.95	1.10	1.25	0.95	1.10	1.25	0.35 x 45°	WEED-2
T1633F-3	0.65	0.80	0.95	0.65	0.80	0.95	0.225 x 45°	WEED-2
T1633FH-3	0.65	0.80	0.95	0.65	0.80	0.95	0.225 x 45°	WEED-2
T1633-4	0.95	1.10	1.25	0.95	1.10	1.25	0.35 x 45°	WEED-2
T1633-5	0.95	1.10	1.25	0.95	1.10	1.25	0.35 x 45°	WEED-2

**NOTES:**

1. DIMENSIONING & TOLERANCING CONFORM TO ASME Y14.5M-1994.
2. ALL DIMENSIONS ARE IN MILLIMETERS. ANGLES ARE IN DEGREES.
3. N IS THE TOTAL NUMBER OF TERMINALS.
4. THE TERMINAL #1 IDENTIFIER AND TERMINAL NUMBERING CONVENTION SHALL CONFORM TO JESD 95-1 SPP-012. DETAILS OF TERMINAL #1 IDENTIFIER ARE OPTIONAL, BUT MUST BE LOCATED WITHIN THE ZONE INDICATED. THE TERMINAL #1 IDENTIFIER MAY BE EITHER A MOLD OR MARKED FEATURE.
5. DIMENSION b APPLIES TO METALLIZED TERMINAL AND IS MEASURED BETWEEN 0.20 mm AND 0.25 mm FROM TERMINAL TIP.
6. ND AND NE REFER TO THE NUMBER OF TERMINALS ON EACH D AND E SIDE RESPECTIVELY.
7. DEPOPULATION IS POSSIBLE IN A SYMMETRICAL FASHION.
8. COPLANARITY APPLIES TO THE EXPOSED HEAT SINK SLUG AS WELL AS THE TERMINALS.
9. DRAWING CONFORMS TO JEDEC MO220 REVISION C.
10. MARKING IS FOR PACKAGE ORIENTATION REFERENCE ONLY.
11. NUMBER OF LEADS SHOWN ARE FOR REFERENCE ONLY.
12. WARPAGE NOT TO EXCEED 0.10mm.

-DRAWING NOT TO SCALE-

<b>DALLAS SEMICONDUCTOR</b>		<b>MAXIM</b>	
TITLE: PACKAGE OUTLINE 8, 12, 16L THIN QFN, 3x3x0.8mm			
APPROVAL	DOCUMENT CONTROL NO.	REV.	2/2
	21-0136	I	

## Revision History

Pages changed at Rev 1: 3, 15

Maxim cannot assume responsibility for use of any circuitry other than circuitry entirely embodied in a Maxim product. No circuit patent licenses are implied. Maxim reserves the right to change the circuitry and specifications without notice at any time.

**Maxim Integrated Products, 120 San Gabriel Drive, Sunnyvale, CA 94086 408-737-7600** \_\_\_\_\_ 15

© 2007 Maxim Integrated Products

**MAXIM** is a registered trademark of Maxim Integrated Products, Inc.