

4-bit constant current power-LED sink driver

Features

- 4 constant current output channels
- Adjustable output current through one external resistor
- Can be driven by a 3.3 V microcontroller
- Serial data IN/parallel data OUT
- Output current: 80-400 mA
- 20 V of output driving capability
- 30 MHz clock frequency
- UVLO (under voltage lockout) and POR (power ON reset)
- TSD, thermal shutdown, output off when junction temperature exceeds limit
- Operating free-air temperature range -40° to 125 °C
- ESD protection 2.5 kV HBM, 200 V MM
- Available in high thermal TSSOP exposed pad.

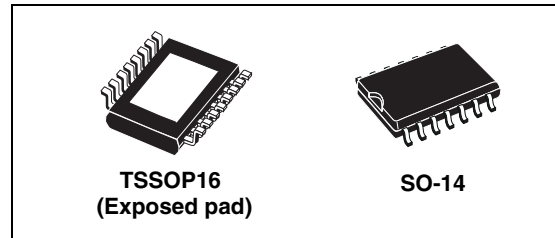

Description

The STP04CM05 is a high-power LED driver and 4-bit shift register designed for Power-LED applications.

The STP04CM05 contains a 4-bit serial IN, parallel OUT shift register that feeds a 4-bit D-type storage register. In the output stage, four regulated current sources were designed to provide 80-400 mA constant current to drive high power LEDs.

The STP04CM05 guarantees 20 V output driving capability, allowing users to connect more LEDs in series. The high clock frequency, 30 MHz, also satisfies the system requirements which include high volume data transmission.

The STP04CM05 is well suited for very high brightness displays and special lighting applications.

The STP04CM05 is offered in SO-14 and TSSOP16 exposed pad packages.

Table 1. Device summary

Order codes	Package	Packaging
STP04CM05MTR	SO-14 (tape and reel)	2500 parts per reel
STP04CM05XTTR	TSSOP16 exposed-pad (tape and reel)	2500 parts per reel

Contents

1	Internal schematic	3
2	Pin settings	4
2.1	Pin connection	4
2.2	Pin description	4
3	Maximum rating	5
3.1	Thermal data	5
3.2	Recommended operating conditions	6
4	Electrical characteristics	7
5	Equivalent circuit of inputs and outputs	9
6	Timing diagrams	11
7	Test circuit	14
8	Typical characteristics	15
9	Package mechanical data	17
10	Revision history	22

1 Internal schematic

Figure 1. Block diagram

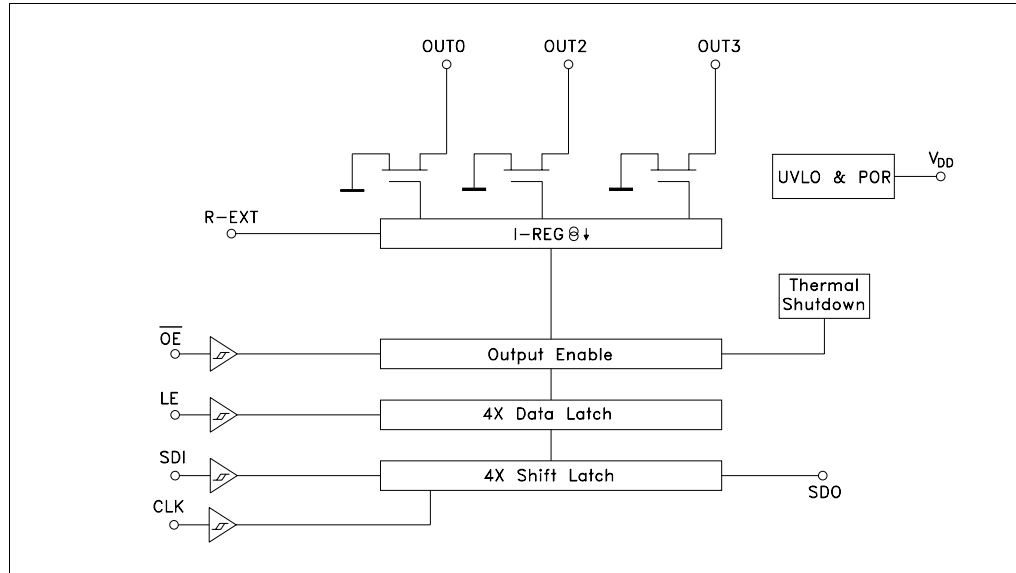

2 Pin settings

2.1 Pin connection

Figure 2. Pin connection

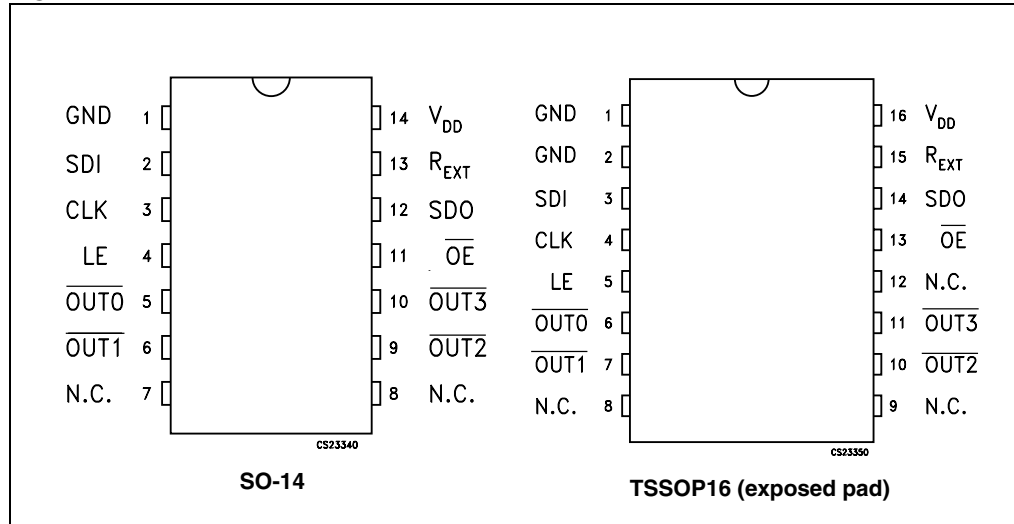

Note: The exposed pad should be electrically connected to a metal land electrically isolated or connected to ground.

2.2 Pin description

Table 2. Pin description

SO-14 pin N°	TSSOP16 pin N°	Symbol	Name and function
1	1, 2	GND	Ground terminal
2	3	SDI	Serial data input terminal
3	4	CLK	Clock input terminal
4	5	LE	Latch input terminal
5	6	OUT 0	Output terminal
6	7	OUT 1	Output terminal
7, 8	8, 9, 12	N.C.	Not connected
9	10	OUT 2	Output terminal
10	11	OUT 3	Output terminal
11	13	OE	Output enable input terminal (active low)
12	14	SDO	Serial data out terminal
13	15	R-EXT	Constant current programming
14	16	V _{DD}	5 V supply voltage terminal

3 Maximum rating

Stressing the device above the rating listed in the “absolute maximum ratings” table may cause permanent damage to the device. These are stress ratings only and operation of the device at these or any other conditions above those indicated in the operating sections of this specification is not implied. Exposure to absolute maximum rating conditions for extended periods may affect device reliability.

Table 3. Absolute maximum ratings

Symbol	Parameter	Value	Unit
V _{DD}	Supply voltage	0 to 7	V
V _O	Output voltage	-0.5 to 20	V
I _O	Output current	500	mA
V _I	Input voltage	-0.4 to V _{DD} +0.4	V
I _{GND}	GND terminal current	2000	mA
f _{CLK}	Clock frequency	50	MHz
T _{OPR}	Operating temperature range	-40 to +125	°C
T _{STG}	Storage temperature range	-55 to +150	°C

3.1 Thermal data

Table 4. Thermal data

Symbol	Parameter	SO-14	TSSOP16	Unit
R _{thJA}	Thermal resistance junction-ambient	105 ⁽¹⁾	37.5 ⁽²⁾	°C/W

- 1 W of dissipated power, mounted on SM PCB1 SGS board
- Using the PCB multi-layer JEDEC Standard test boards

3.2 Recommended operating conditions

Table 5. Recommended operating conditions

Symbol	Parameter	Test conditions	Min.	Typ.	Max.	Unit
V_{DD}	Supply voltage		3.3	5.0	5.5	V
V_O	Output voltage				19	V
I_O	Output current	OUTn $V_{DD} = 5\text{ V}$	80		400	mA
I_{OH}	Output current	Serial-OUT			+1	mA
I_{OL}	Output current	Serial-OUT			-1	mA
V_{IH}	Input voltage		$0.7V_{DD}$		$V_{DD}+0.3$	V
V_{IL}	Input voltage		-0.3		$0.3V_{DD}$	V
t_{WEN}	\overline{OE} pulse width	$V_{DD} = 5\text{ V}$, $I_O = 350\text{ mA}$	80	50		ns
		$V_{DD} = 3.3\text{ V}$, $I_O = 350\text{ mA}$	250	150		
t_{WLAT}	LE pulse width	$V_{DD} = 3.0\text{ to }3.6\text{ V}$	8	4		ns
t_{WCLK}	CLK pulse width		8.5	7.5		ns
$t_{SETUP(D)}$	Setup time for DATA		8.5	7.5		ns
$t_{HOLD(D)}$	Hold time for DATA		8.5	7.5		ns
$t_{SETUP(L)}$	Setup time for LATCH		8.5	7.0		ns
$t_{HOLD(E)}$	Hold time for ENABLE		8.5	7.0		ns
f_{CLK}	Clock frequency		Cascade operation ⁽¹⁾			30
T_{OPR}	Operating temperature range		-40		+125	°C

1. If multiple devices are cascaded, it may not be possible to achieve the maximum data transfer. Please consider the timing conditions carefully.

4 Electrical characteristics

$T_A = 25\text{ }^\circ\text{C}$, unless otherwise specified.

Table 6. Current accuracy

Output voltage	Current accuracy		Output current
	Between bits	Between ICs	
$\geq 1.4\text{ V}$	Typ. $\pm 1\%$	$\pm 6\%$	80 to 400 mA

Table 7. Electrical characteristics ($V_{DD} = 3.3\text{ to }5\text{ V}$)

Symbol	Parameter	Test conditions	Min.	Typ.	Max.	Unit
V_{IH}	Input voltage high level		$0.7 V_{DD}$		V_{DD}	V
V_{IL}	Input voltage low level		GND		$0.3 V_{DD}$	V
I_{OH}	Output leakage current	$V_{OH} = 19\text{ V}$			10	μA
V_{OL}	Output voltage (Serial-OUT)	$I_{OL} = 1\text{ mA}$			0.4	V
V_{OH}	Output voltage (Serial-OUT)	$I_{OH} = -1\text{ mA}$	$V_{DD}-0.4\text{V}$			V
I_{OL1}	Output current	$V_O = 0.3 V_{R_{EXT}} = 980\ \Omega$	75.2	80	84.8	mA
I_{OL2}		$V_O = 1.2 V_{R_{EXT}} = 190\ \Omega$	376	400	424	mA
ΔI_{OL1}	Output current error between bit (all output ON)	$V_O = 0.3 V_{R_{EXT}} = 980\ \Omega$ $I_O = 80\text{ mA}$		1	1.5	%
ΔI_{OL2}		$V_O = 1.2 V_{R_{EXT}} = 190\ \Omega$ $I_O = 400\text{ mA}$		1	1.5	%
$R_{SIN(up)}$	Pull-up resistor		150	300	600	$\text{k}\Omega$
$R_{SIN(down)}$	Pull-down resistor		100	200	400	$\text{k}\Omega$
$I_{DD(OFF1)}$	Supply current (OFF)	$R_{EXT} = \text{OPEN}$ OUT 0 to 3 = OFF		1	1.5	mA
$I_{DD(OFF2)}$		$R_{EXT} = 980\ \Omega$ OUT 0 to 3 = OFF		3.8	6	
$I_{DD(OFF3)}$		$R_{EXT} = 190\ \Omega$ OUT 0 to 3 = OFF		14	18.5	
$I_{DD(ON1)}$	Supply current (ON)	$R_{EXT} = 980\ \Omega$ OUT 0 to 3 = ON		4.0	6.0	
$I_{DD(ON2)}$		$R_{EXT} = 190\ \Omega$ OUT 0 to 3 = ON		14.5	19	

Table 8. Switching characteristics ($V_{DD} = 3.3$ to 5 V)

Symbol	Parameter	Test conditions	Min.	Typ.	Max.	Unit	
t_{PLH1}	Propagation delay time, CLK- \overline{OUTn} , LE = H, $\overline{OE} = L$		$V_{DD} = 3.3$ V	-	290	377	ns
			$V_{DD} = 5$ V	-	200	260	
t_{PLH2}	Propagation delay time, LE- \overline{OUTn} , $\overline{OE} = L$		$V_{DD} = 3.3$ V	-	200	260	ns
			$V_{DD} = 5$ V	-	140	180	
t_{PLH3}	Propagation delay time, \overline{OE} - \overline{OUTn} , LE = H		$V_{DD} = 3.3$ V	-	240	310	ns
			$V_{DD} = 5$ V	-	170	220	
t_{PLH}	Propagation delay time, CLK-SDO		$V_{DD} = 3.3$ V	-	25	35	ns
			$V_{DD} = 5$ V	-	15	20	
t_{PHL1}	Propagation delay time, CLK- \overline{OUTn} , LE = H, $\overline{OE} = L$	$R_L = 5.0 \Omega$ $C_L = 10$ pF $I_O = 350$ mA $R_{ext} = 224 \Omega$ $V_L = 3.0$ V	$V_{DD} = 3.3$ V	-	49	64	ns
			$V_{DD} = 5$ V	-	36	47	
t_{PHL2}	Propagation delay time, LE- \overline{OUTn} , $\overline{OE} = L$		$V_{DD} = 3.3$ V	-	39	51	ns
			$V_{DD} = 5$ V	-	26	34	
t_{PHL3}	Propagation delay time, \overline{OE} - \overline{OUTn} , LE = H		$V_{DD} = 3.3$ V	-	48	62	ns
			$V_{DD} = 5$ V	-	32	42	
t_{PHL}	Propagation delay time, CLK-SDO		$V_{DD} = 3.3$ V	-	30	39	ns
			$V_{DD} = 5$ V	-	19	25	
t_{ON}	Output rise time 10~90% of voltage waveform		$V_{DD} = 3.3$ V	-	880	1150	ns
			$V_{DD} = 5$ V	-	616	800	
t_{OFF}	Output fall time 90~10% of voltage waveform		$V_{DD} = 3.3$ V	-	18	24	ns
			$V_{DD} = 5$ V	-	14	18	
t_r	CLK rise time ⁽¹⁾	$V_O = 5.0$ V		-	5000	ns	
t_f	CLK fall time ⁽¹⁾	$R_{ext} = 224 \Omega$		-	5000	ns	

1. In order to achieve high cascade data transfer, please consider t_r/t_f timings carefully.

5 Equivalent circuit of inputs and outputs

Figure 3. \overline{OE} terminal

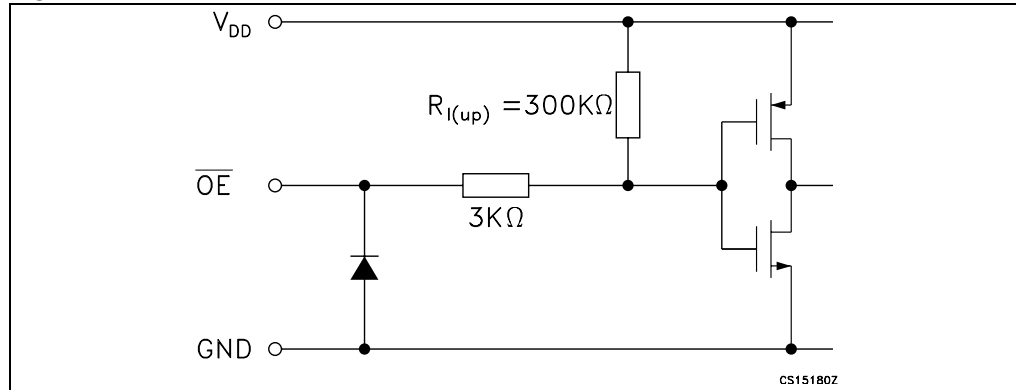

Figure 4. LE terminal

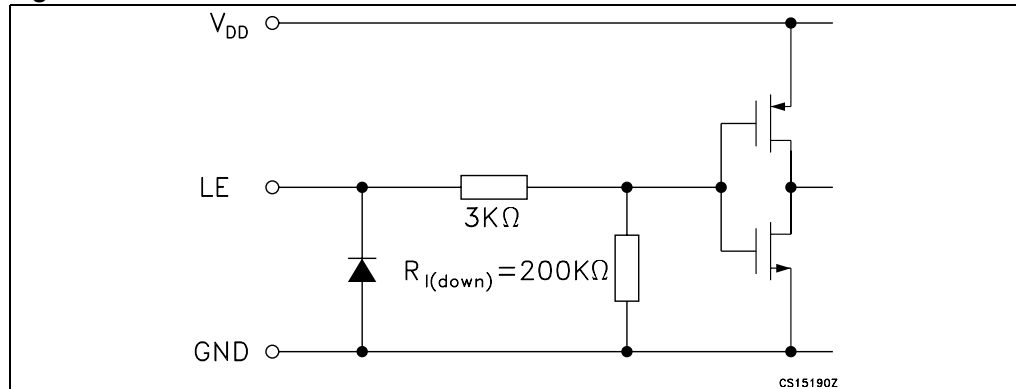

Figure 5. CLK, SDI terminal

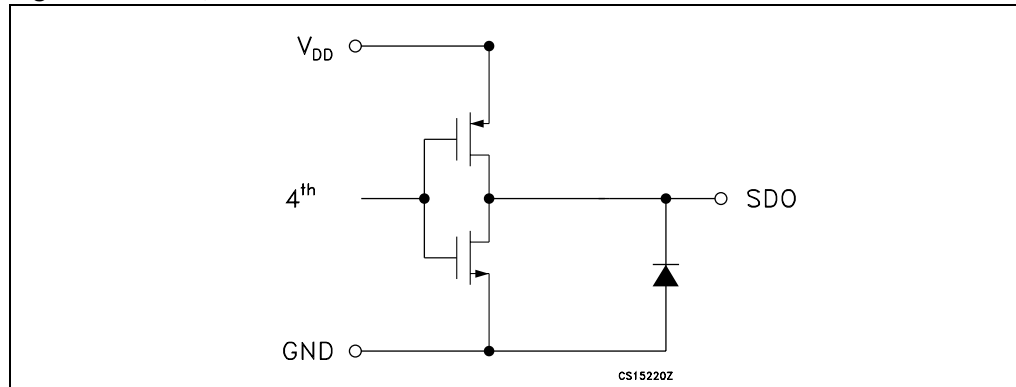
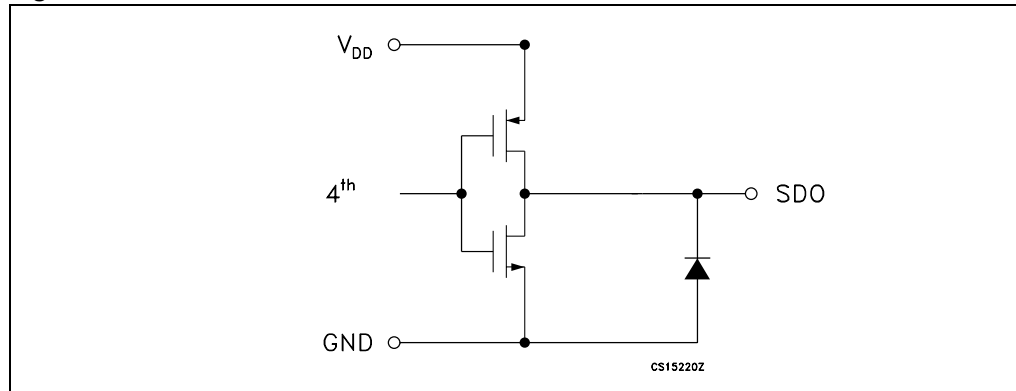
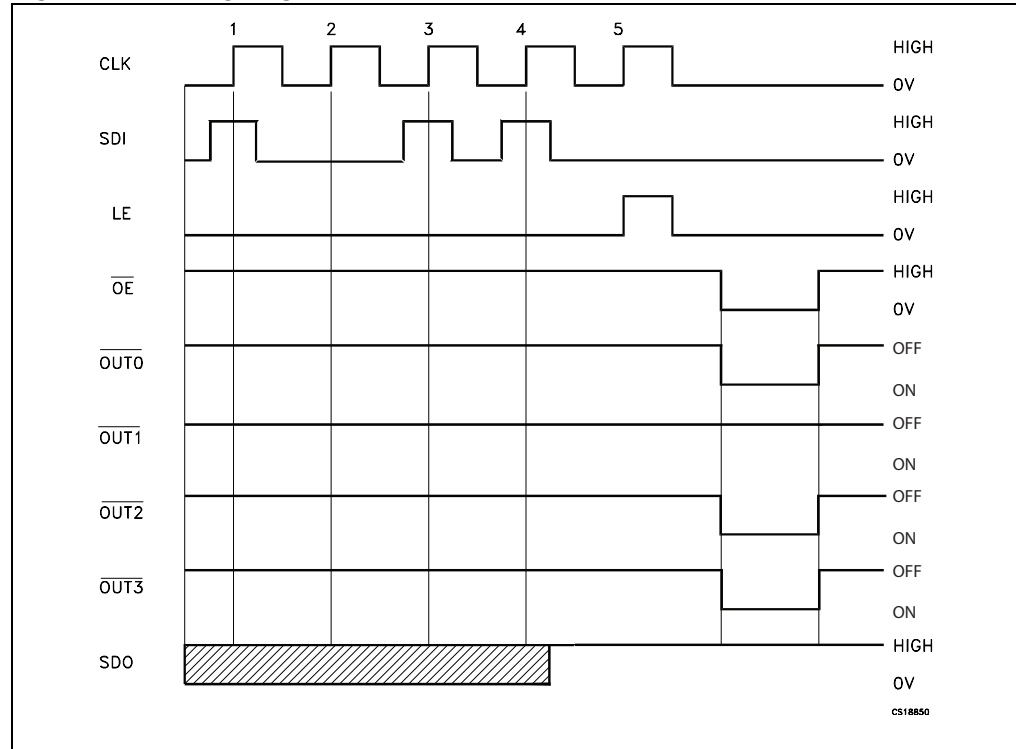

Figure 6. SDO terminal



6 Timing diagrams

Figure 7. Timing diagram



- Note:
- 1 Latch and output enable are level sensitive and are not synchronized with rising-or-falling edge of CLK signal.
 - 2 When LE terminal is low level, the latch circuit hold previous set of data.
 - 3 When LE terminal is high level, the latch circuit refresh new set of data from SDI chain.
 - 4 When OE terminal is at low level, the output terminal - Out 0 to Out 03 respond to data in the latch circuits, either '1' for ON or '0' for OFF.
 - 5 When OE terminal is at high level, all output terminals will be switched OFF.

Figure 8. Clock, serial-in, serial-out

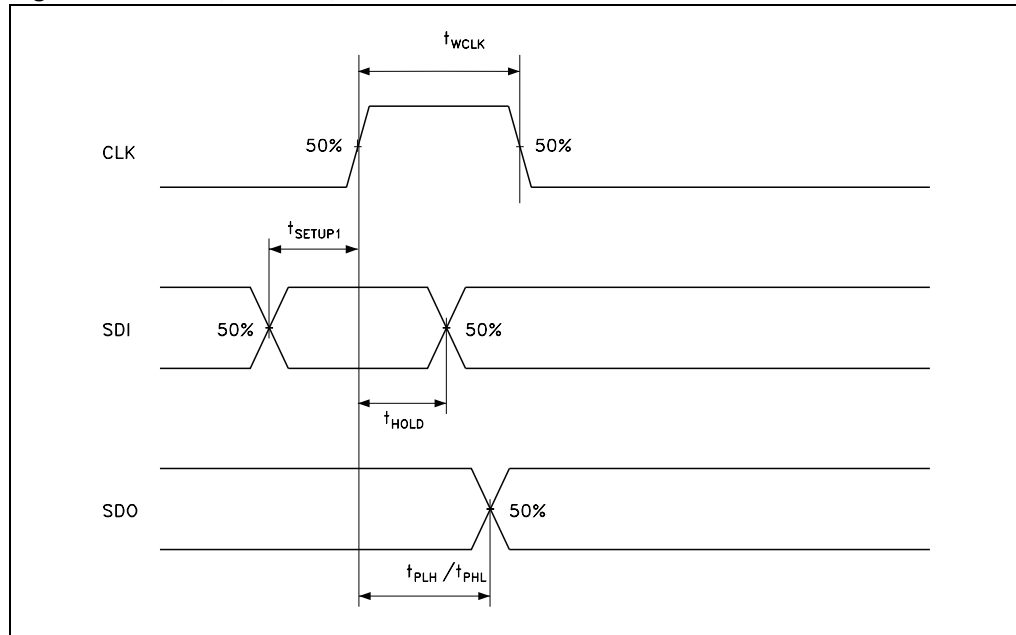

Figure 9. Clock, serial-in, latch, enable, outputs

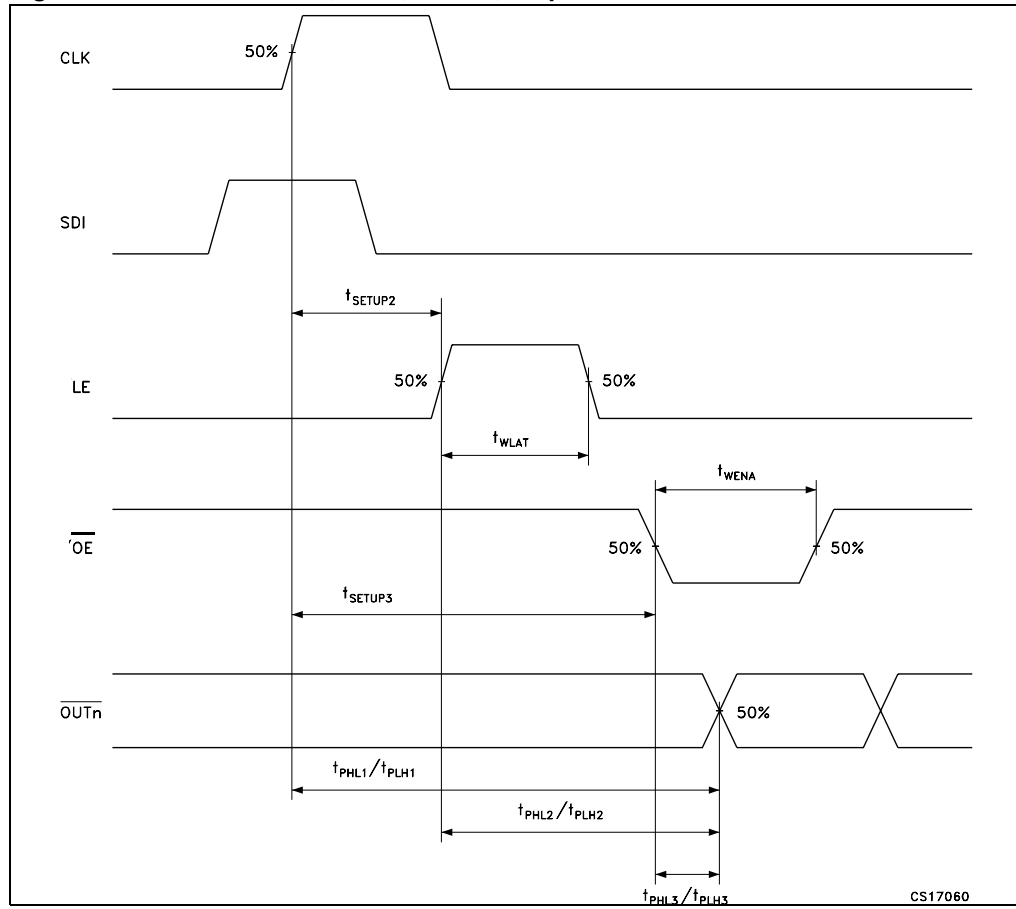
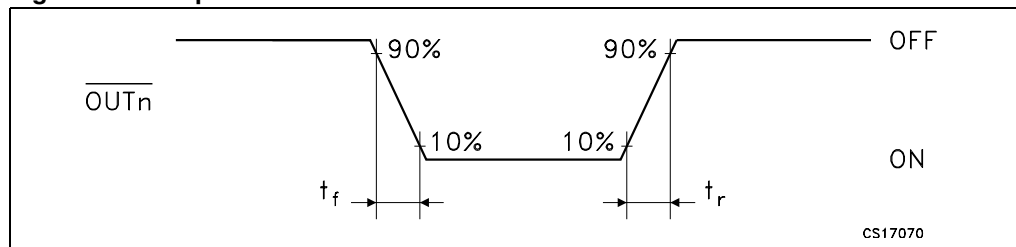

Figure 10. Outputs



7 Test circuit

Figure 11. DC characteristic

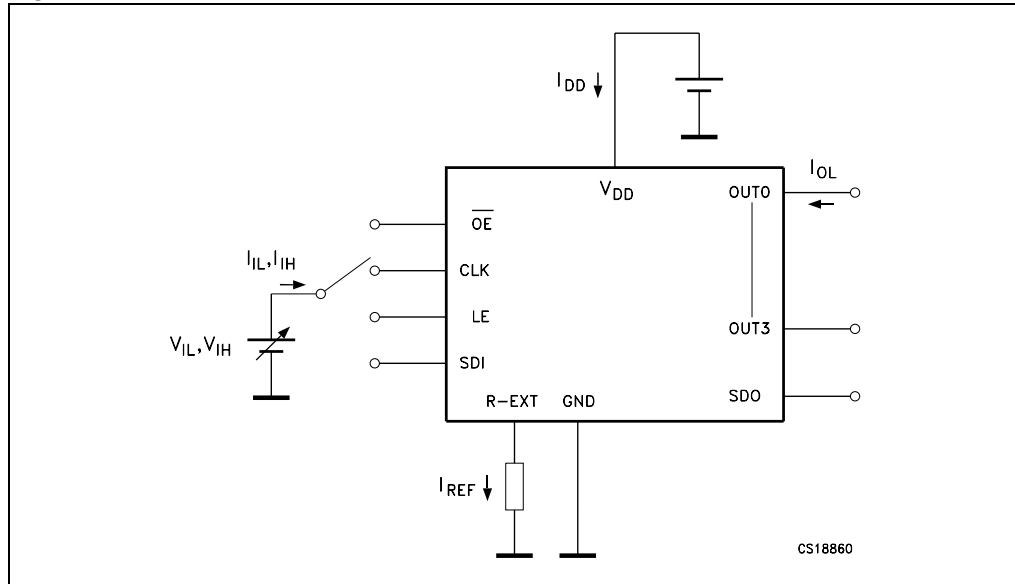
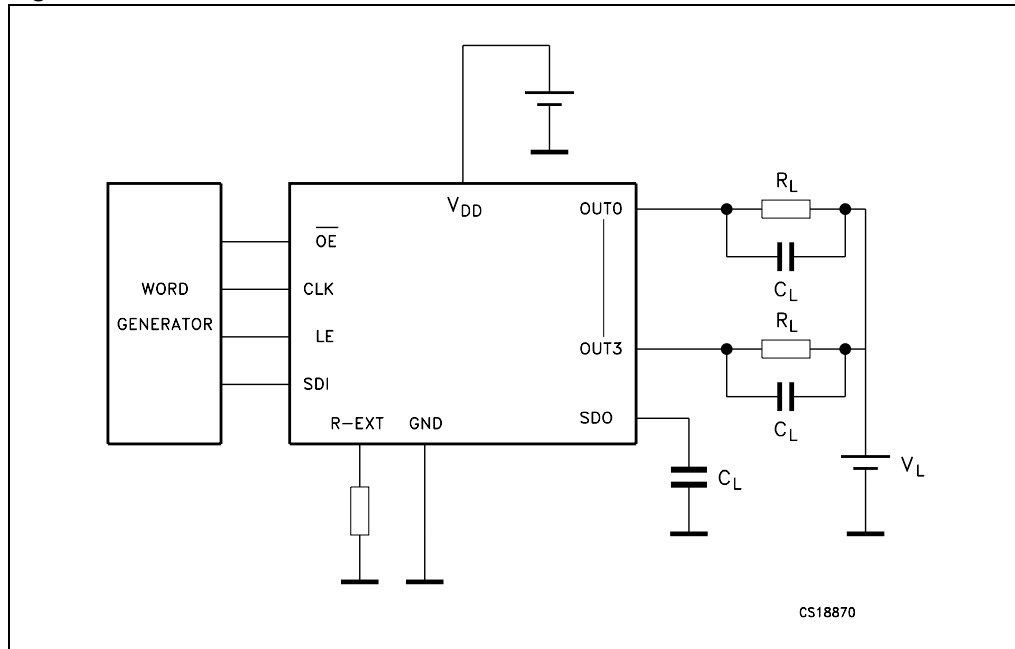

Figure 12. AC characteristic



8 Typical characteristics

Figure 13. Output current- R_{EXT} resistor

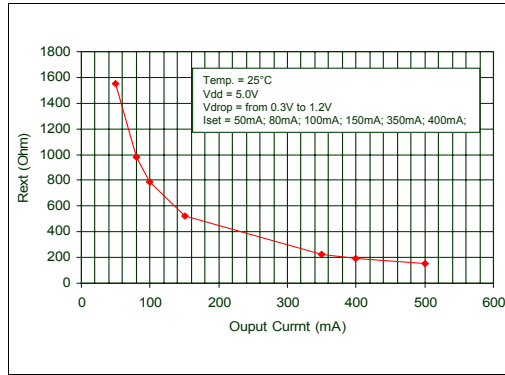

Figure 14. Output current vs dropout voltage

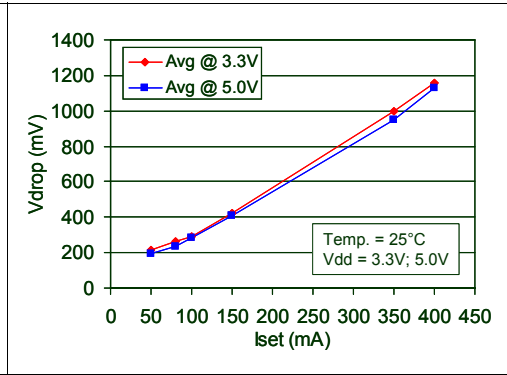

Figure 15. Output current vs $\pm \Delta I_{OL}(\%)$

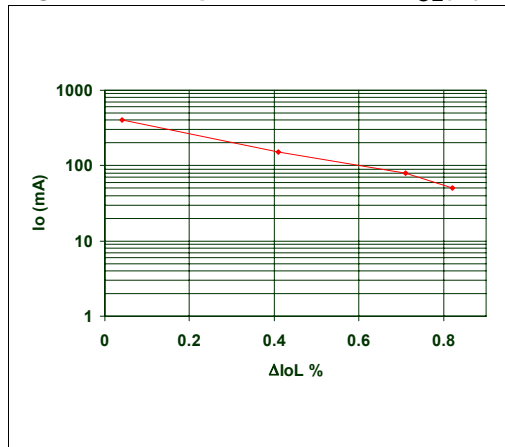
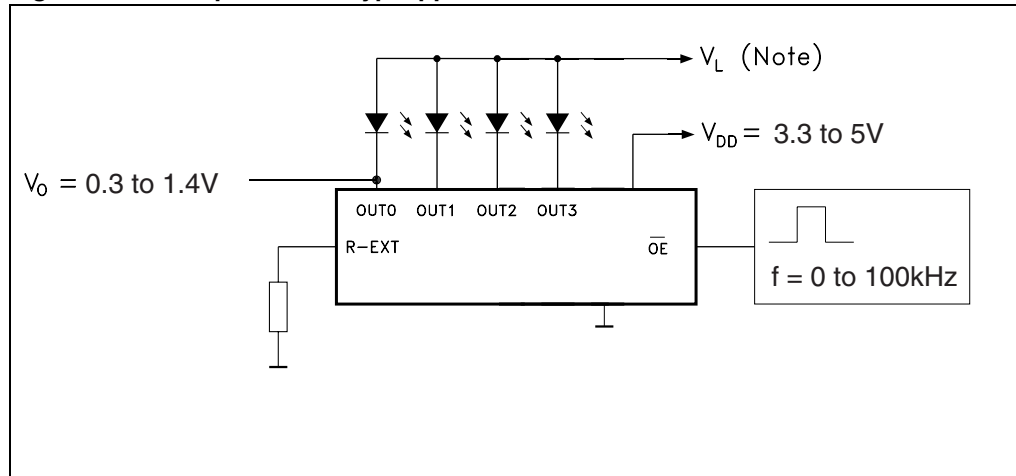

Figure 16. Four power-LED typ. application circuit



Note: V_L will be determined by the V_F of the LEDs

Condition: $T_A = 25\text{ }^\circ\text{C}$, $V_{dd} = 5\text{ V}$, $V_L = 3\text{ V}$, $R_{ext} = 227\text{ }\Omega$

Figure 17. t_{ON}

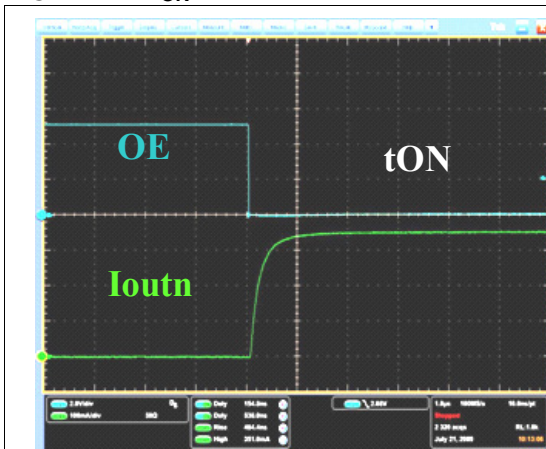
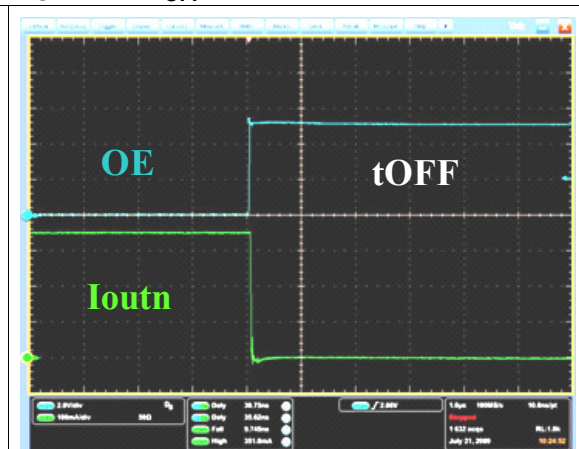

Figure 18. t_{OFF}



9 Package mechanical data

In order to meet environmental requirements, ST offers these devices in different grades of ECOPACK® packages, depending on their level of environmental compliance. ECOPACK® specifications, grade definitions and product status are available at: www.st.com. ECOPACK® is an ST trademark.

Table 9. SO-14 mechanical data

Dim.	mm.			inch		
	Min	Typ	Max	Min	Typ	Max
A			1.75			0.068
a1	0.1		0.2	0.003		0.007
a2			1.65			0.064
b	0.35		0.46	0.013		0.018
b1	0.19		0.25	0.007		0.010
C		0.5			0.019	
c1	45° (typ.)					
D	8.55		8.75	0.336		0.344
E	5.8		6.2	0.228		0.244
e		1.27			0.050	
e3		7.62			0.300	
F	3.8		4.0	0.149		0.157
G	4.6		5.3	0.181		0.208
L	0.5		1.27	0.019		0.050
M			0.68			0.026
S	8° (max.)					

Figure 19. Package dimensions

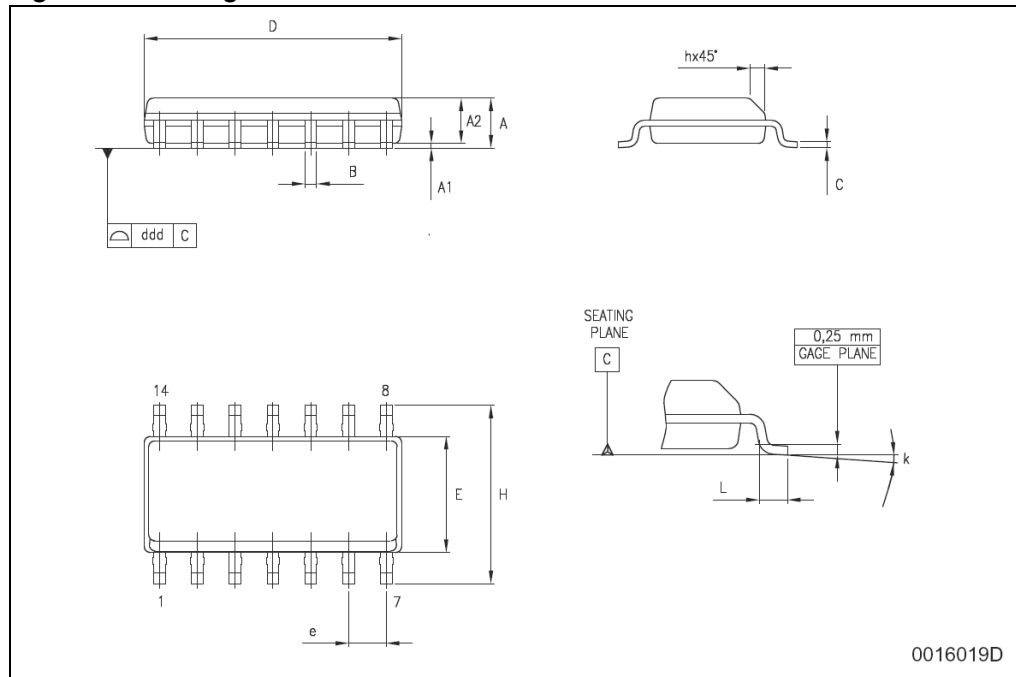

Table 10. TSSOP16 exposed-pad mechanical data

Dim.	mm.		
	Min	Typ	Max
A			1.2
A1			0.15
A2	0.8	1	1.05
b	0.19		0.3
c	0.09		0.2
D	4.9	5	5.1
D1	2.7	3.0	3.3
E	6.2	6.4	6.6
E1	4.3	4.4	4.5
E2	2.7	3.0	3.3
e		0.65	
K	0°		8°
L	0.45	0.6	0.75

Figure 20. TSSOP16 exposed-pad mechanical data

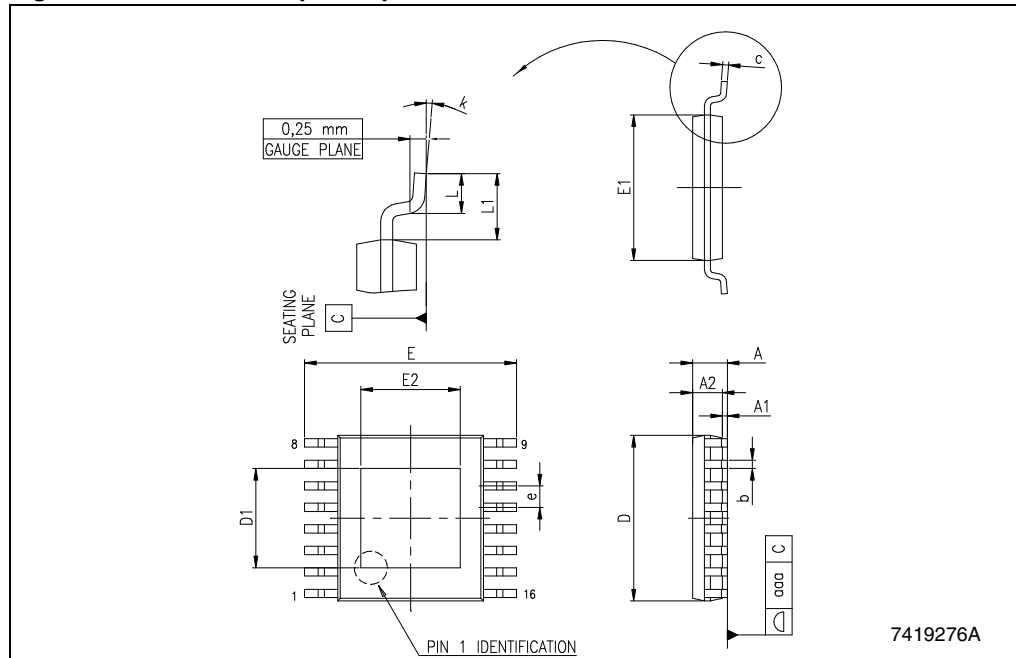

Table 11. Tape and reel SO-14

Dim.	mm.			inch		
	Min	Typ	Max	Min	Typ	Max
A			330			12.992
C	12.8		13.2	0.504		0.519
D	20.2			0.795		
N	60			2.362		
T			22.4			0.882
Ao	6.4		6.6	0.252		0.260
Bo	9		9.2	0.354		0.362
Ko	2.1		2.3	0.082		0.090
Po	3.9		4.1	0.153		0.161
P	7.9		8.1	0.311		0.319

Figure 21. Tape and reel dimensions

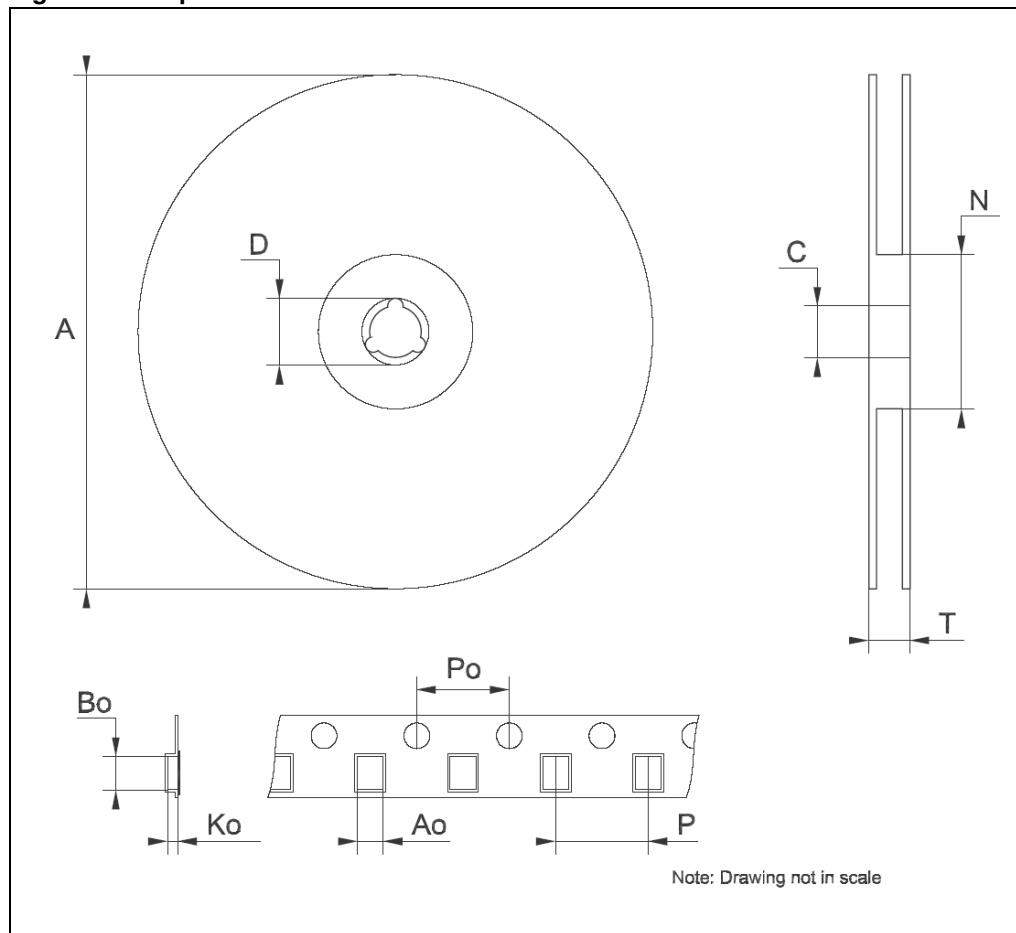
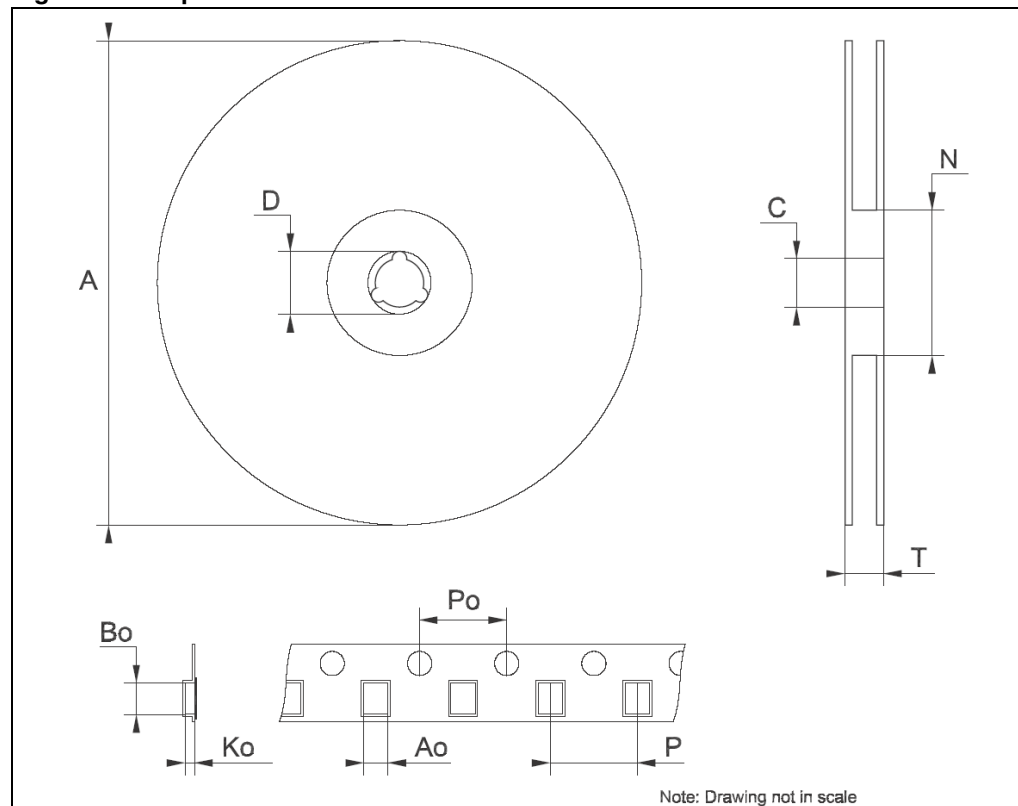

Table 12. TSSOP16 tape and reel

Dim.	mm.			inch		
	Min	Typ	Max	Min	Typ	Max
A			330			12.992
C	12.8		13.2	0.504		0.519
D	20.2			0.795		
N	60			2.362		
T			22.4			0.882
Ao	6.7		6.9	0.264		0.272
Bo	5.3		5.5	0.209		0.217
Ko	1.6		1.8	0.063		0.071
Po	3.9		4.1	0.153		0.161
P	7.9		8.1	0.311		0.319

Figure 22. Tape and reel dimensions



10 Revision history

Table 13. Document revision history

Date	Revision	Changes
26-Nov-2007	1	Initial release
16-Jan-2008	2	Added: Figure 15 on page 15 and Figure 19 on page 17 , Updated: Table 8 on page 8 .
12-Mar-2008	3	Updated: Figure 8 on page 12 .
23-Jun-2008	4	Updated: Table 1 on page 1 , Figure 21 on page 20 .
07-Jun-2010	5	Updated: Note: on page 4 , Table 10 on page 19 .

Please Read Carefully:

Information in this document is provided solely in connection with ST products. STMicroelectronics NV and its subsidiaries ("ST") reserve the right to make changes, corrections, modifications or improvements, to this document, and the products and services described herein at any time, without notice.

All ST products are sold pursuant to ST's terms and conditions of sale.

Purchasers are solely responsible for the choice, selection and use of the ST products and services described herein, and ST assumes no liability whatsoever relating to the choice, selection or use of the ST products and services described herein.

No license, express or implied, by estoppel or otherwise, to any intellectual property rights is granted under this document. If any part of this document refers to any third party products or services it shall not be deemed a license grant by ST for the use of such third party products or services, or any intellectual property contained therein or considered as a warranty covering the use in any manner whatsoever of such third party products or services or any intellectual property contained therein.

UNLESS OTHERWISE SET FORTH IN ST'S TERMS AND CONDITIONS OF SALE ST DISCLAIMS ANY EXPRESS OR IMPLIED WARRANTY WITH RESPECT TO THE USE AND/OR SALE OF ST PRODUCTS INCLUDING WITHOUT LIMITATION IMPLIED WARRANTIES OF MERCHANTABILITY, FITNESS FOR A PARTICULAR PURPOSE (AND THEIR EQUIVALENTS UNDER THE LAWS OF ANY JURISDICTION), OR INFRINGEMENT OF ANY PATENT, COPYRIGHT OR OTHER INTELLECTUAL PROPERTY RIGHT.

UNLESS EXPRESSLY APPROVED IN WRITING BY AN AUTHORIZED ST REPRESENTATIVE, ST PRODUCTS ARE NOT RECOMMENDED, AUTHORIZED OR WARRANTED FOR USE IN MILITARY, AIR CRAFT, SPACE, LIFE SAVING, OR LIFE SUSTAINING APPLICATIONS, NOR IN PRODUCTS OR SYSTEMS WHERE FAILURE OR MALFUNCTION MAY RESULT IN PERSONAL INJURY, DEATH, OR SEVERE PROPERTY OR ENVIRONMENTAL DAMAGE. ST PRODUCTS WHICH ARE NOT SPECIFIED AS "AUTOMOTIVE GRADE" MAY ONLY BE USED IN AUTOMOTIVE APPLICATIONS AT USER'S OWN RISK.

Resale of ST products with provisions different from the statements and/or technical features set forth in this document shall immediately void any warranty granted by ST for the ST product or service described herein and shall not create or extend in any manner whatsoever, any liability of ST.

ST and the ST logo are trademarks or registered trademarks of ST in various countries.

Information in this document supersedes and replaces all information previously supplied.

The ST logo is a registered trademark of STMicroelectronics. All other names are the property of their respective owners.

© 2010 STMicroelectronics - All rights reserved

STMicroelectronics group of companies

Australia - Belgium - Brazil - Canada - China - Czech Republic - Finland - France - Germany - Hong Kong - India - Israel - Italy - Japan - Malaysia - Malta - Morocco - Philippines - Singapore - Spain - Sweden - Switzerland - United Kingdom - United States of America

www.st.com

