

LM2705

Micropower Step-up DC/DC Converter with 150mA Peak Current Limit

General Description

The LM2705 is a micropower step-up DC/DC in a small 5-lead SOT-23 package. A current limited, fixed off-time control scheme conserves operating current resulting in high efficiency over a wide range of load conditions. The 21V switch allows for output voltages as high as 20V. The low 400ns off-time permits the use of tiny, low profile inductors and capacitors to minimize footprint and cost in space-conscious portable applications. The LM2705 is ideal for LCD panels requiring low current and high efficiency as well as white LED applications for cellular phone back-lighting. The LM2705 can drive up to 3 white LEDs from a single Li-Ion battery. The low peak inductor current of the LM2705 makes it ideal for USB applications.

Features

- 150mA, 0.7Ω, internal switch
- Uses small surface mount components
- Adjustable output voltage up to 20V
- 2.2V to 7V input range
- Input undervoltage lockout
- 0.01μA shutdown current
- Small 5-Lead SOT-23 package

Applications

- LCD Bias Supplies
- White LED Back-Lighting
- Handheld Devices
- Digital Cameras
- Portable Applications

Typical Application Circuit

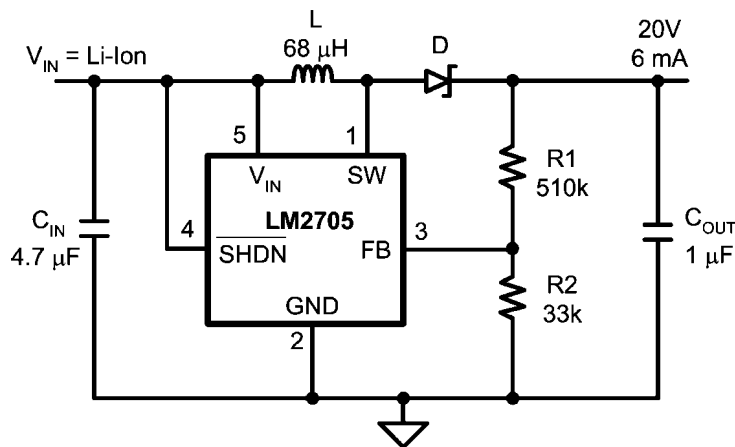

C_{IN} : Taiyo Yuden Ceramic
 C_{OUT} : Taiyo Yuden Ceramic
 L: Coilcraft DT1608C-683
 D: ON Semiconductor MBRM130LT3

20039701

FIGURE 1. Typical 20V Application

Connection Diagram

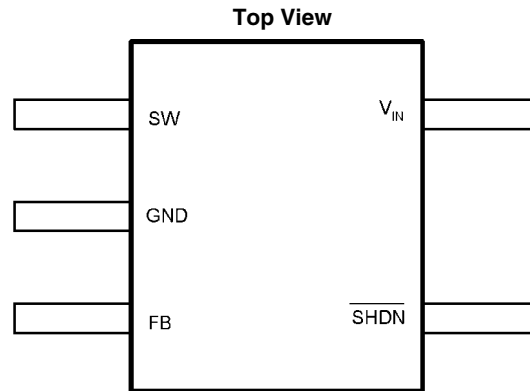

20039702

SOT23-5
 $T_{Jmax} = 125^{\circ}\text{C}$, $\theta_{JA} = 220^{\circ}\text{C/W}$ (Note 2)

Ordering Information

Order Number	Package Type	NSC Package Drawing	Top Mark	Supplied As
LM2705MF-ADJ	SOT23-5	MA05B	S59B	1000 Units, Tape and Reel
LM2705MFX-ADJ	SOT23-5	MA05B	S59B	3000 Units, Tape and Reel

Pin Descriptions/Functions

Pin	Name	Function
1	SW	Power Switch input.
2	GND	Ground.
3	FB	Output voltage feedback input.
4	$\overline{\text{SHDN}}$	Shutdown control input, active low.
5	V_{IN}	Analog and Power input.

SW(Pin 1): Switch Pin. This is the drain of the internal NMOS power switch. Minimize the metal trace area connected to this pin to minimize EMI.

GND(Pin 2): Ground Pin. Tie directly to ground plane.

FB(Pin 3): Feedback Pin. Set the output voltage by selecting values for R1 and R2 using:

$$R1 = R2 \left(\frac{V_{OUT}}{1.237V} - 1 \right)$$

Connect the ground of the feedback network to an AGND plane which should be tied directly to the GND pin.

$\overline{\text{SHDN}}$ (Pin 4): Shutdown Pin. The shutdown pin is an active low control. Tie this pin above 1.1V to enable the device. Tie this pin below 0.3V to turn off the device.

V_{IN} (Pin 5): Input Supply Pin. Bypass this pin with a capacitor as close to the device as possible.

Absolute Maximum Ratings *(Note 1)*

If Military/Aerospace specified devices are required, please contact the National Semiconductor Sales Office/Distributors for availability and specifications.

V_{IN}	7.5V
SW Voltage	21V
FB Voltage	2V
\overline{SHDN} Voltage	7.5V
Maximum Junction Temp. T_J <i>(Note 2)</i>	150°C
Lead Temperature (Soldering 10 sec.)	300°C

Vapor Phase (60 sec.)	215°C
Infrared (15 sec.)	220°C
ESD Ratings <i>(Note 3)</i>	
Human Body Model	2kV
Machine Model <i>(Note 4)</i>	200V

Operating Conditions

Junction Temperature <i>(Note 5)</i>	-40°C to +125°C
Supply Voltage	2.2V to 7V
SW Voltage Max.	20.5V

Electrical Characteristics

Specifications in standard type face are for $T_J = 25^\circ\text{C}$ and those in **boldface type** apply over the full **Operating Temperature Range** ($T_J = -40^\circ\text{C}$ to $+125^\circ\text{C}$). Unless otherwise specified $V_{IN} = 2.2\text{V}$.

Symbol	Parameter	Conditions	Min <i>(Note 5)</i>	Typ <i>(Note 6)</i>	Max <i>(Note 5)</i>	Units
I_Q	Device Disabled	FB = 1.3V		40	70	μA
	Device Enabled	FB = 1.2V		235	300	
	Shutdown	$\overline{SHDN} = 0\text{V}$		0.01	2.5	
V_{FB}	Feedback Trip Point		1.189	1.237	1.269	V
I_{CL}	Switch Current Limit		100	150	180	mA
I_B	FB Pin Bias Current	FB = 1.23V <i>(Note 7)</i>		30	120	nA
V_{IN}	Input Voltage Range		2.2		7.0	V
R_{DSON}	Switch R_{DSON}			0.7	1.6	Ω
T_{OFF}	Switch Off Time			400		ns
I_{SD}	SHDN Pin Current	$\overline{SHDN} = V_{IN}, T_J = 25^\circ\text{C}$		0	80	nA
		$\overline{SHDN} = V_{IN}, T_J = 125^\circ\text{C}$		15		
		$\overline{SHDN} = \text{GND}$		0		
I_L	Switch Leakage Current	$V_{SW} = 20\text{V}$		0.05	5	μA
UVP	Input Undervoltage Lockout	ON/OFF Threshold		1.8		V
V_{FB} Hysteresis	Feedback Hysteresis			8		mV
\overline{SHDN} Threshold	SHDN low			0.7	0.3	V
	SHDN High		1.1	0.7		
θ_{JA} SOT23-5	Thermal Resistance			220		$^\circ\text{C}/\text{W}$

Note 1: Absolute maximum ratings are limits beyond which damage to the device may occur. Operating Ratings are conditions for which the device is intended to be functional, but device parameter specifications may not be guaranteed. For guaranteed specifications and test conditions, see the Electrical Characteristics.

Note 2: The maximum allowable power dissipation is a function of the maximum junction temperature, $T_{J(\text{MAX})}$, the junction-to-ambient thermal resistance, θ_{JA} , and the ambient temperature, T_A . See the Electrical Characteristics table for the thermal resistance. The maximum allowable power dissipation at any ambient temperature is calculated using: $P_D(\text{MAX}) = (T_{J(\text{MAX})} - T_A)/\theta_{JA}$. Exceeding the maximum allowable power dissipation will cause excessive die temperature.

Note 3: The human body model is a 100 pF capacitor discharged through a 1.5 k Ω resistor into each pin. The machine model is a 200 pF capacitor discharged directly into each pin.

Note 4: ESD susceptibility using the machine model is 150V for SW pin.

Note 5: All limits guaranteed at room temperature (standard typeface) and at temperature extremes (bold typeface). All room temperature limits are 100% production tested or guaranteed through statistical analysis. All limits at temperature extremes are guaranteed via correlation using standard Statistical Quality Control (SQC) methods. All limits are used to calculate Average Outgoing Quality Level (AOQL).

Note 6: Typical numbers are at 25°C and represent the most likely norm.

Note 7: Feedback current flows into the pin.

Typical Performance Characteristics

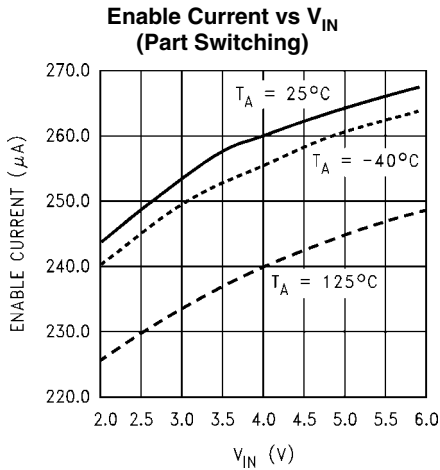

20039705

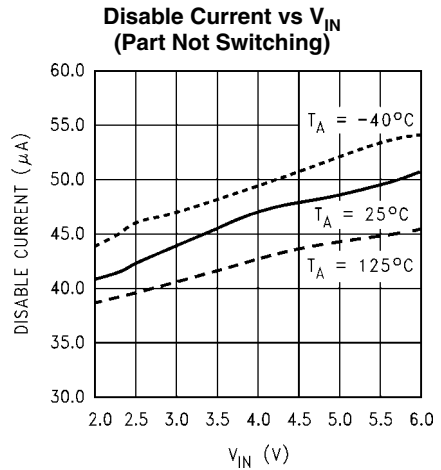

20039706

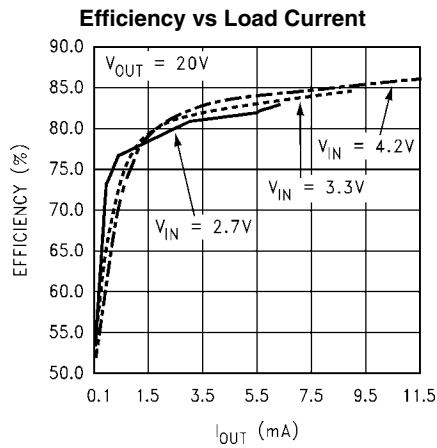

20039724

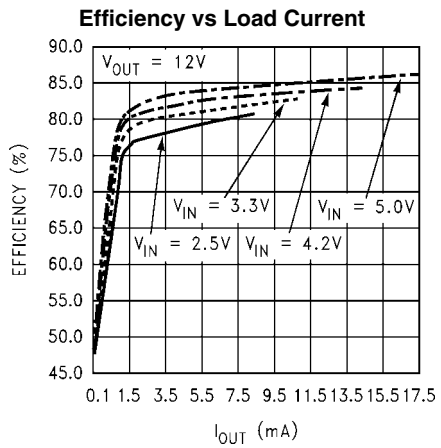

20039725

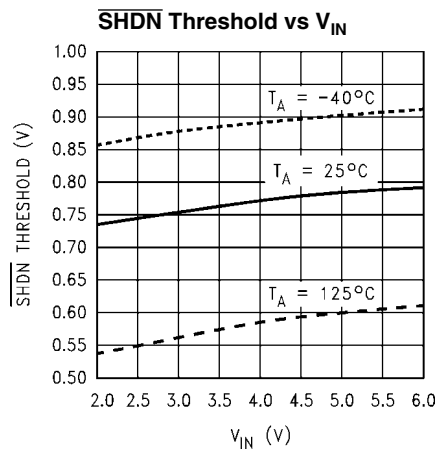

20039713

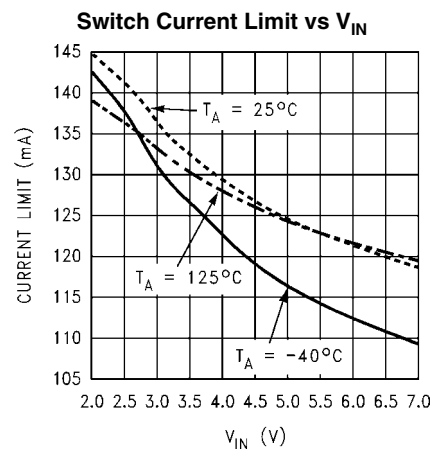

20039737

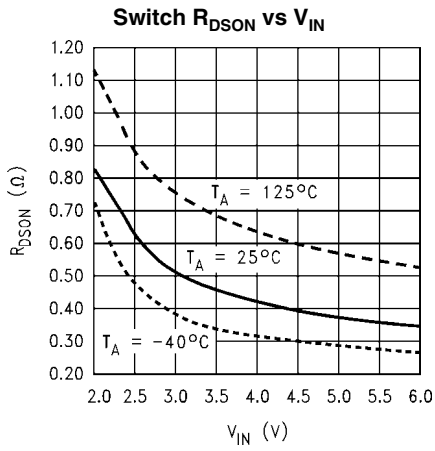

20039715

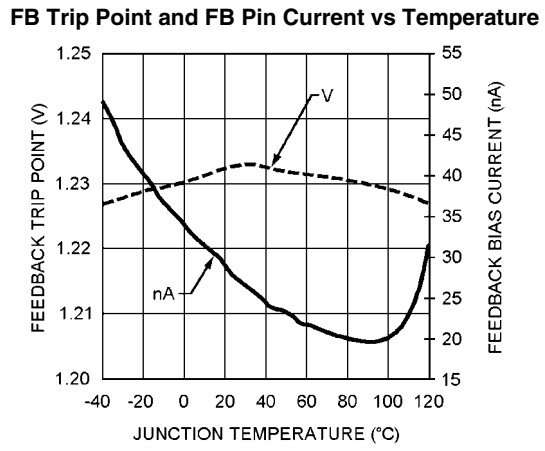

20039723

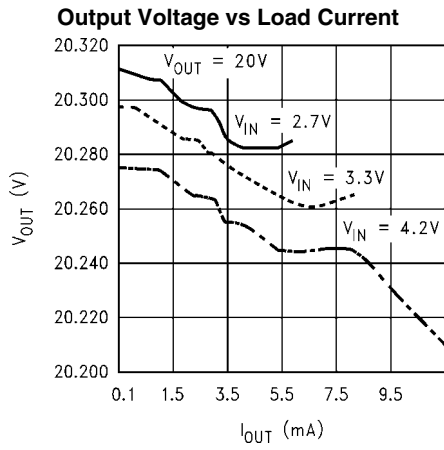

20039727

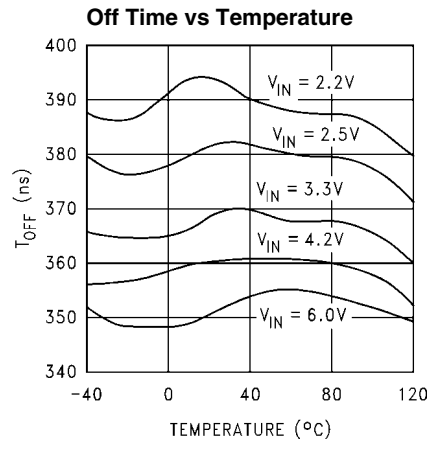

20039741

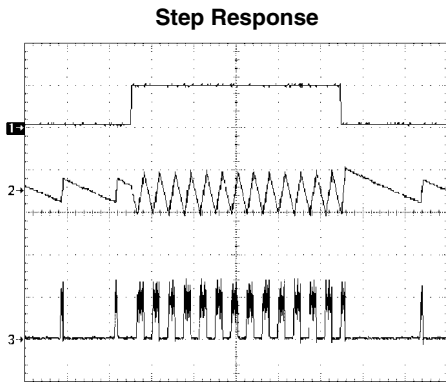

20039728

$V_{OUT} = 20V$, $V_{IN} = 3.0V$
 1) Load, 0.5mA to 5mA to 0.5mA, DC
 2) V_{OUT} , 200mV/div, AC
 3) I_L , 100mA/div, DC
 T = 100 μ s/div

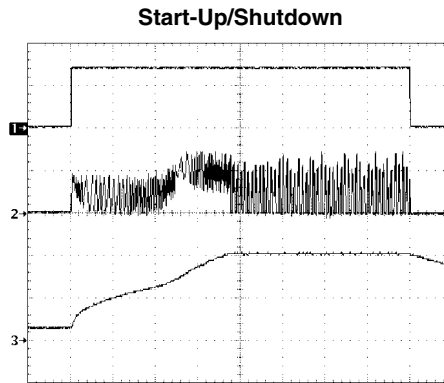

20039729

$V_{OUT} = 20V$, $V_{IN} = 3.0V$
 1) SHDN, 1V/div, DC
 2) I_L , 100mA/div, DC
 3) V_{OUT} , 10V/div, DC
 T = 400 μ s/div
 $R_L = 3.9k\Omega$

Operation

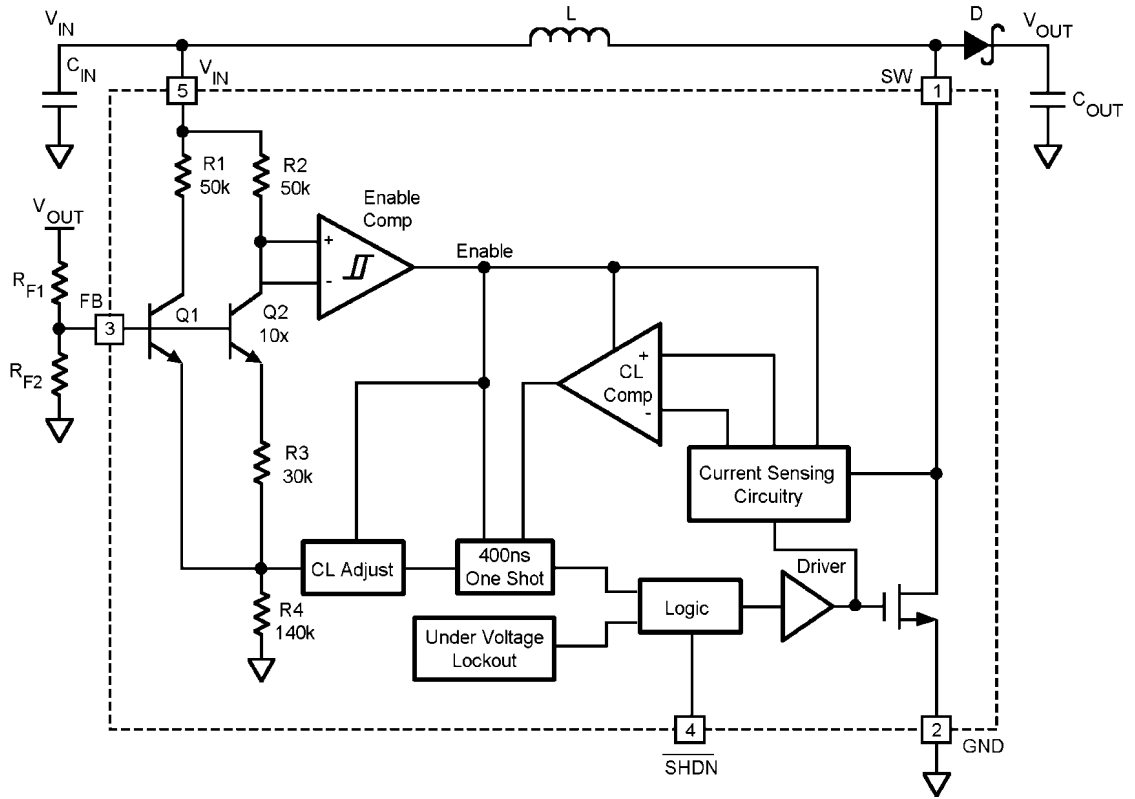

20039704

FIGURE 2. LM2705 Block Diagram

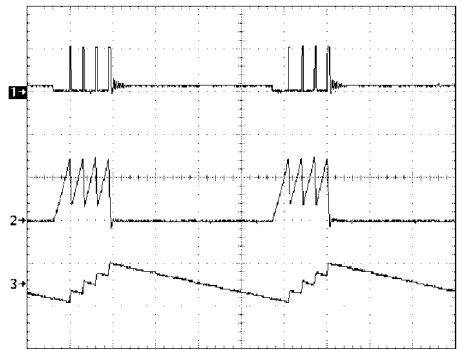

20039730

$V_{OUT} = 20V$, $V_{IN} = 2.7V$, $I_{OUT} = 2.5mA$
 1) V_{SW} , 20V/div, DC
 2) Inductor Current, 100mA/div, DC
 3) V_{OUT} , 200mV/div, AC
 $T = 10\mu s/div$

FIGURE 3. Typical Switching Waveform

The LM2705 features a constant off-time control scheme. Operation can be best understood by referring to [Figure 2](#) and [Figure 3](#). Transistors Q1 and Q2 and resistors R3 and R4 of [Figure 2](#) form a bandgap reference used to control the output voltage. When the voltage at the FB pin is less than 1.237V, the Enable Comp in [Figure 2](#) enables the device and the NMOS switch is turned on pulling the SW pin to ground. When the NMOS switch is on, current begins to flow through inductor L while the load current is supplied by the output capacitor C_{OUT} . Once the current in the inductor reaches the current limit, the CL Comp trips and the 400ns One Shot turns off the NMOS switch. The SW voltage will then rise to the output voltage plus a diode drop and the inductor current will begin to decrease as shown in [Figure 3](#). During this time the energy stored in the inductor is transferred to C_{OUT} and the load. After the 400ns off-time the NMOS switch is turned on and energy is stored in the inductor again. This energy transfer from the inductor to the output causes a stepping effect in the output ripple as shown in [Figure 3](#).

This cycle is continued until the voltage at FB reaches 1.237V. When FB reaches this voltage, the enable comparator then disables the device turning off the NMOS switch and reducing the I_q of the device to 40 μ A. The load current is then supplied solely by C_{OUT} indicated by the gradually decreasing slope at the output as shown in [Figure 3](#). When the FB pin drops slightly below 1.237V, the enable comparator enables the device and begins the cycle described previously. The \overline{SHDN} pin can be used to turn off the LM2705 and reduce the I_q to 0.01 μ A. In shutdown mode the output voltage will be a diode drop lower than the input voltage.

Application Information

INDUCTOR SELECTION - BOOST REGULATOR

The appropriate inductor for a given application is calculated using the following equation:

$$L = \left(\frac{V_{OUT} - V_{IN(min)} + V_D}{I_{CL}} \right) T_{OFF}$$

where V_D is the schottky diode voltage, I_{CL} is the switch current limit found in the *Typical Performance Characteristics* section, and T_{OFF} is the switch off time. When using this equation be sure to use the minimum input voltage for the application, such as for battery powered applications. For the LM2705 constant-off time control scheme, the NMOS power switch is turned off when the current limit is reached. There is approximately a 100ns delay from the time the current limit is reached in the NMOS power switch and when the internal logic actually turns off the switch. During this 100ns delay, the peak inductor current will increase. This increase in inductor current demands a larger saturation current rating for the inductor. This saturation current can be approximated by the following equation:

$$I_{PK} = I_{CL} + \left(\frac{V_{IN(max)}}{L} \right) 100 \text{ ns}$$

Choosing inductors with low ESR decrease power losses and increase efficiency.

Care should be taken when choosing an inductor. For applications that require an input voltage that approaches the output voltage, such as when converting a Li-Ion battery voltage to 5V, the 400ns off time may not be enough time to

discharge the energy in the inductor and transfer the energy to the output capacitor and load. This can cause a ramping effect in the inductor current waveform and an increased ripple on the output voltage. Using a smaller inductor will cause the I_{PK} to increase and will increase the output voltage ripple further.

For typical curves and evaluation purposes the DT1608C series inductors from Coilcraft were used. Other acceptable inductors would include, but are not limited to, the SLF6020T series from TDK, the NP05D series from Taiyo Yuden, the CDRH4D18 series from Sumida, and the P1166 series from Pulse.

INDUCTOR SELECTION - SEPIC REGULATOR

The following equation can be used to calculate the approximate inductor value for a SEPIC regulator:

$$L2 = 2 \left(\frac{V_{OUT} + V_D}{I_{CL}} \right) T_{OFF}$$

The boost inductor, L1, can be smaller or larger but is generally chosen to be the same value as L2. See [Figure 9](#) and [Figure 10](#) for typical SEPIC applications.

DIODE SELECTION

To maintain high efficiency, the average current rating of the schottky diode should be larger than the peak inductor current, I_{PK} . Schottky diodes with a low forward drop and fast switching speeds are ideal for increasing efficiency in portable applications. Choose a reverse breakdown of the schottky diode larger than the output voltage.

CAPACITOR SELECTION

Choose low ESR capacitors for the output to minimize output voltage ripple. Multilayer ceramic capacitors are the best choice. For most applications, a 1 μ F ceramic capacitor is sufficient. For some applications a reduction in output voltage ripple can be achieved by increasing the output capacitor. Output voltage ripple can further be reduced by adding a 4.7pF feed-forward capacitor in the feedback network placed in parallel with RF1, see [Figure 2](#).

Local bypassing for the input is needed on the LM2705. Multilayer ceramic capacitors are a good choice for this as well. A 4.7 μ F capacitor is sufficient for most applications. For additional bypassing, a 100nF ceramic capacitor can be used to shunt high frequency ripple on the input.

LAYOUT CONSIDERATIONS

The input bypass capacitor C_{IN} , as shown in [Figure 1](#), must be placed close to the IC. This will reduce copper trace resistance which effects input voltage ripple of the IC. For additional input voltage filtering, a 100nF bypass capacitor can be placed in parallel with C_{IN} to shunt any high frequency noise to ground. The output capacitor, C_{OUT} , should also be placed close to the IC. Any copper trace connections for the Cout capacitor can increase the series resistance, which directly effects output voltage ripple. The feedback network, resistors R1 and R2, should be kept close to the FB pin to minimize copper trace connections that can inject noise into the system. The ground connection for the feedback resistor network should connect directly to an analog ground plane. The analog ground plane should tie directly to the GND pin. If no analog ground plane is available, the ground connection for the feedback network should tie directly to the GND pin. Trace connections made to the inductor and schottky diode

should be minimized to reduce power dissipation and increase overall efficiency.

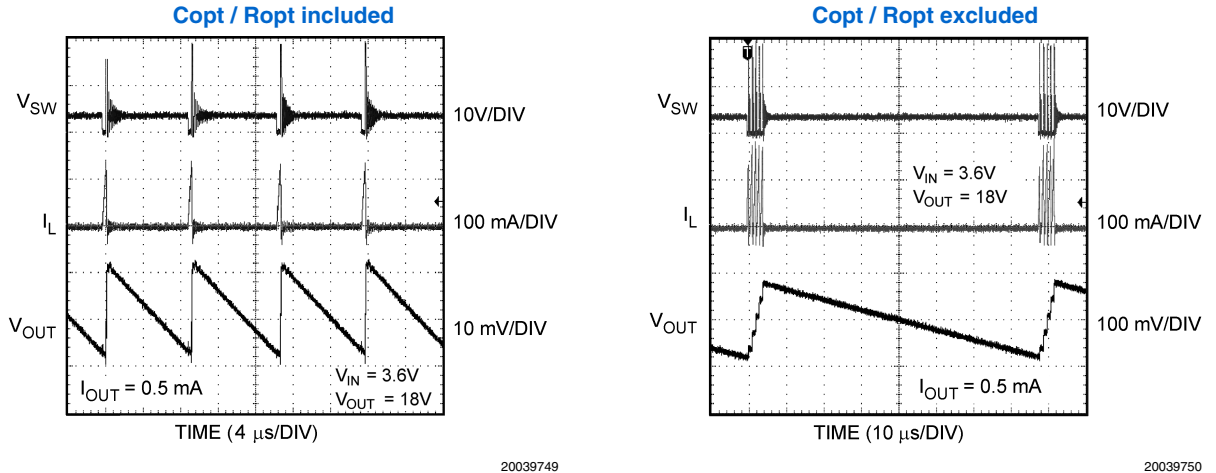
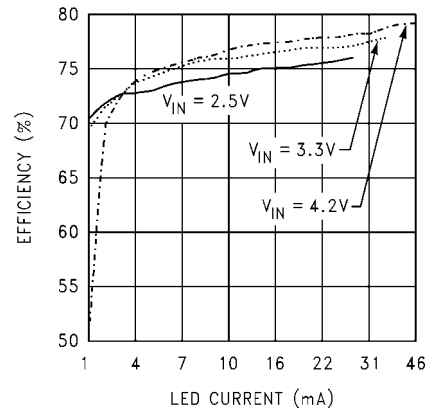
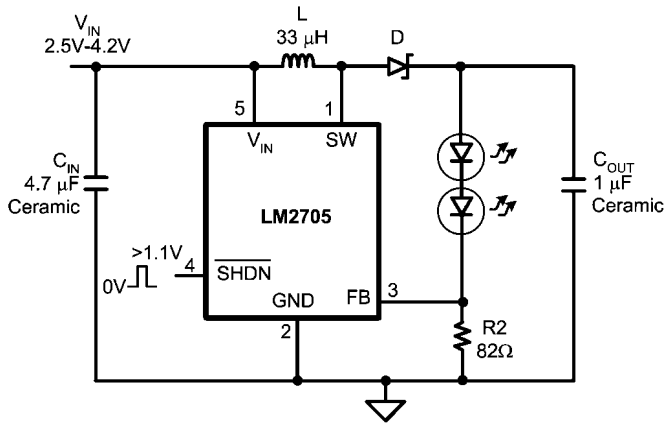

FIGURE 4. Output Ripple Voltage



C_{IN}: Taiyo Yuden Ceramic
 C_{OUT}: Taiyo Yuden Ceramic
 L: Coilcraft DT1608C-333
 D: ON Semiconductor MBRM130LT3

20039709

FIGURE 5. 2 White LED Application and Efficiency

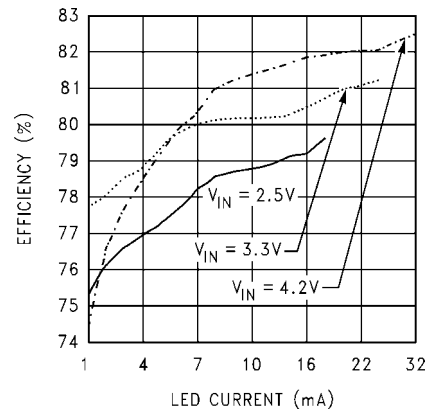
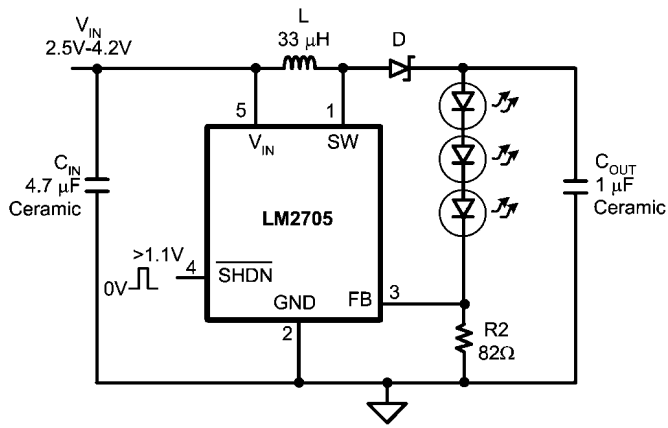

20039743

C_{IN}: Taiyo Yuden Ceramic
 C_{OUT}: Taiyo Yuden Ceramic
 L: Coilcraft DT1608C-333
 D: ON Semiconductor MBRM130LT3

20039734

FIGURE 6.3 White LED Application and Efficiency

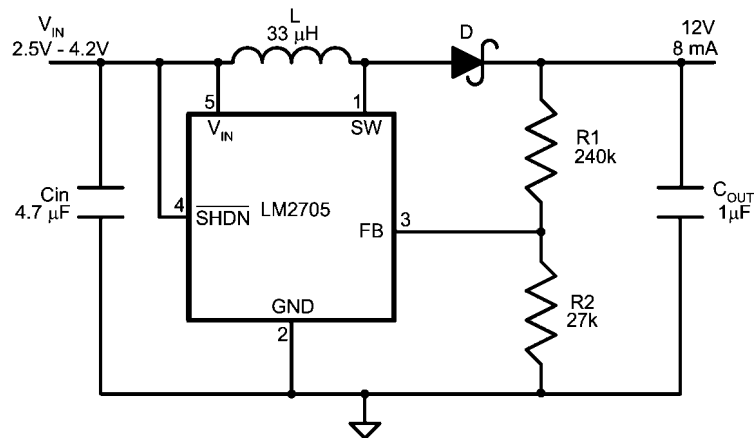

C_{IN}: Taiyo Yuden Ceramic
 C_{OUT}: Taiyo Yuden Ceramic
 L: Coilcraft DT1608C-333
 D: ON Semiconductor MBRM130LT3

20039735

FIGURE 7. Li-Ion 12V Application

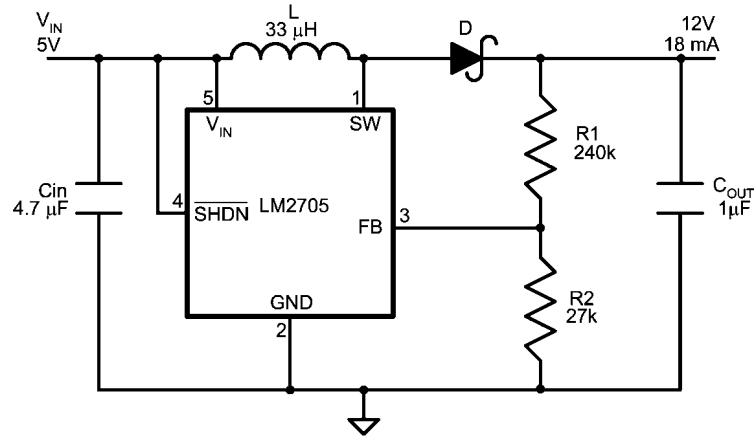

C_{IN} : Taiyo Yuden Ceramic
 C_{OUT} : Taiyo Yuden Ceramic
 L: Coilcraft DT1608C-333
 D: ON Semiconductor MBRM130LT3

20039736

FIGURE 8. 5V to 12V Application

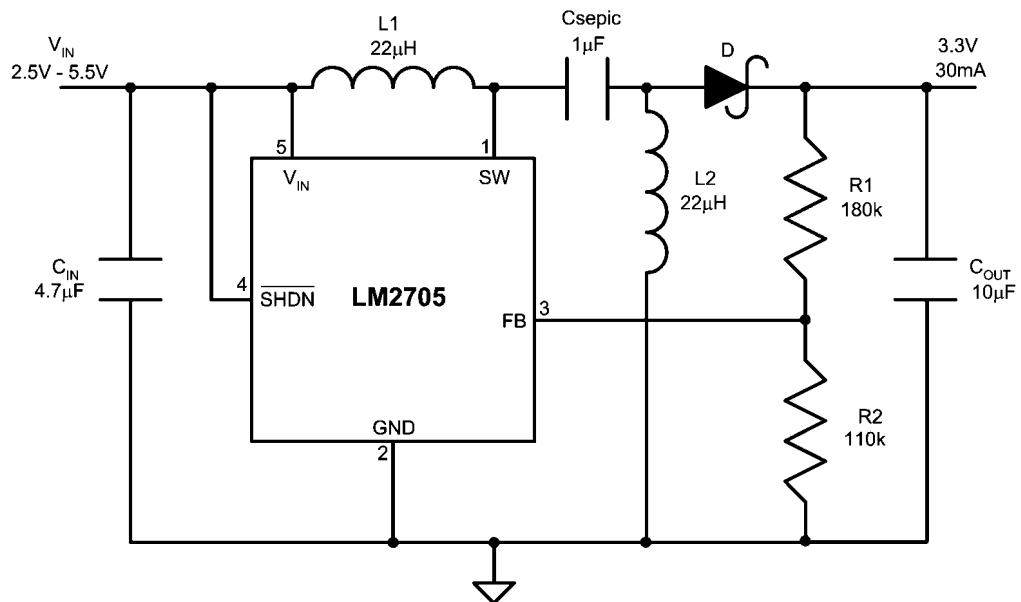

C_{sepic} : Taiyo Yuden Ceramic
 C_{IN} : Taiyo Yuden Ceramic
 C_{OUT} : Taiyo Yuden Ceramic
 L1, L2: Coilcraft DT1608C-223
 D: ON Semiconductor MBRM130LT3

20039739

FIGURE 9. 3.3V SEPIC Application

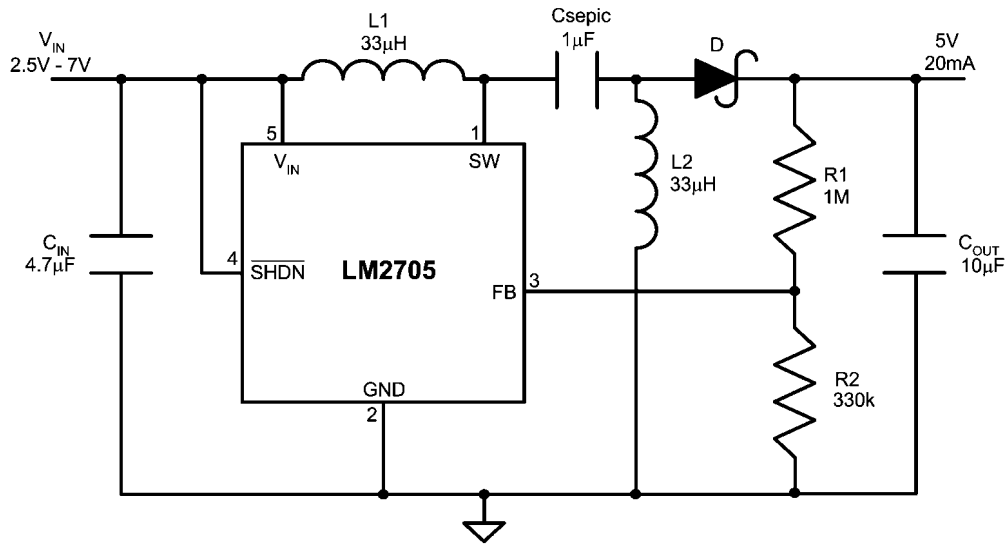

Csepic: Taiyo Yuden Ceramic
 C_{IN}: Taiyo Yuden Ceramic
 C_{OUT}: Taiyo Yuden Ceramic
 L1, L2: Coilcraft DT1608C-333
 D: ON Semiconductor MBRM130LT3

20039740

FIGURE 10. 5V SEPIC Application

Physical Dimensions inches (millimeters) unless otherwise noted

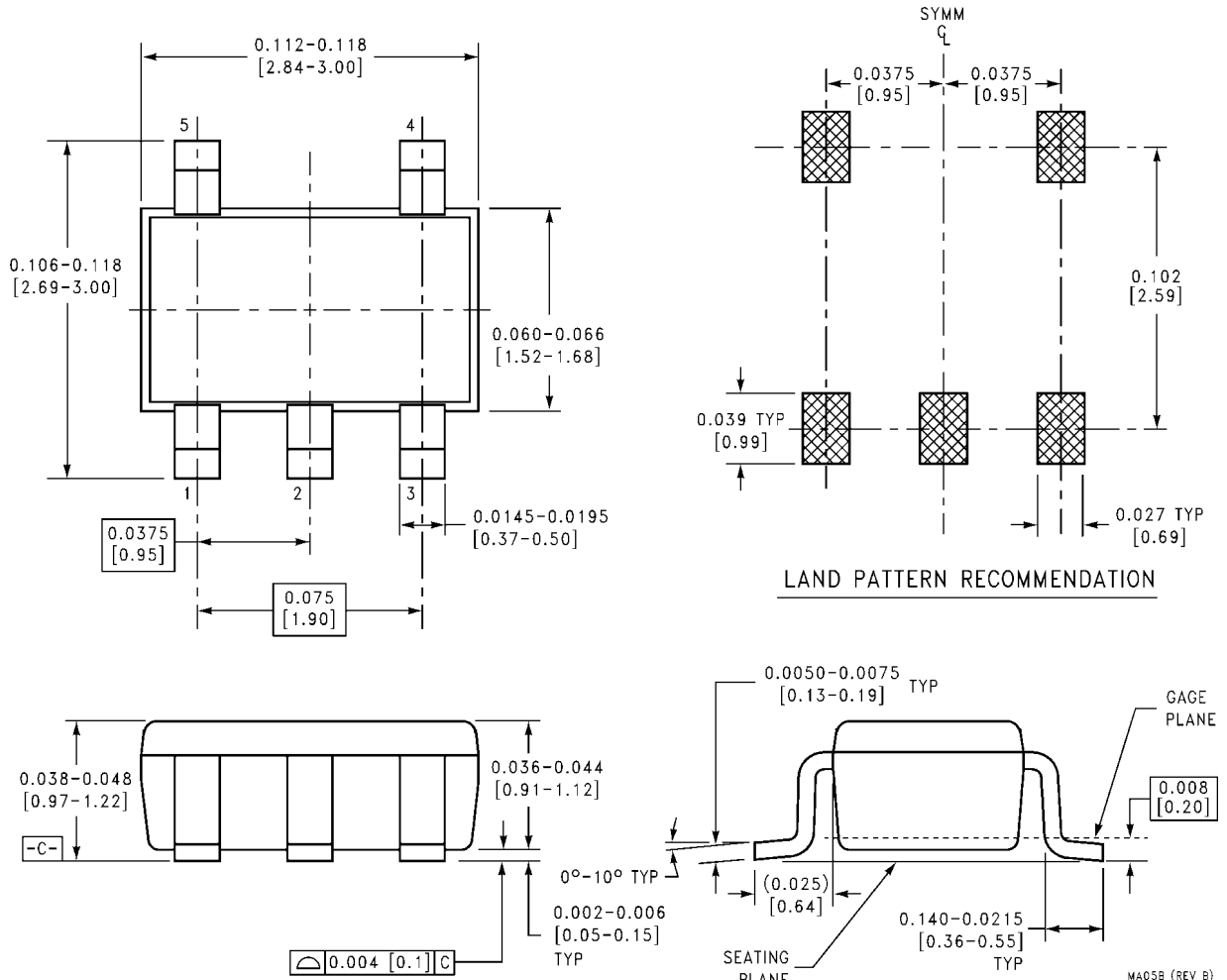

5-Lead Small Outline Package (M5)
For Ordering, Refer to Ordering Information Table
NS Package Number MA05B

MA05B (REV B)

Notes

LM2705

Notes

For more National Semiconductor product information and proven design tools, visit the following Web sites at:
www.national.com

Products		Design Support	
Amplifiers	www.national.com/amplifiers	WEBENCH® Tools	www.national.com/webench
Audio	www.national.com/audio	App Notes	www.national.com/appnotes
Clock and Timing	www.national.com/timing	Reference Designs	www.national.com/refdesigns
Data Converters	www.national.com/adc	Samples	www.national.com/samples
Interface	www.national.com/interface	Eval Boards	www.national.com/evalboards
LVDS	www.national.com/lvds	Packaging	www.national.com/packaging
Power Management	www.national.com/power	Green Compliance	www.national.com/quality/green
Switching Regulators	www.national.com/switchers	Distributors	www.national.com/contacts
LDOs	www.national.com/lido	Quality and Reliability	www.national.com/quality
LED Lighting	www.national.com/led	Feedback/Support	www.national.com/feedback
Voltage References	www.national.com/vref	Design Made Easy	www.national.com/easy
PowerWise® Solutions	www.national.com/powerwise	Applications & Markets	www.national.com/solutions
Serial Digital Interface (SDI)	www.national.com/sdi	Mil/Aero	www.national.com/milaero
Temperature Sensors	www.national.com/tempensors	SolarMagic™	www.national.com/solarmagic
PLL/VCO	www.national.com/wireless	PowerWise® Design University	www.national.com/training

THE CONTENTS OF THIS DOCUMENT ARE PROVIDED IN CONNECTION WITH NATIONAL SEMICONDUCTOR CORPORATION ("NATIONAL") PRODUCTS. NATIONAL MAKES NO REPRESENTATIONS OR WARRANTIES WITH RESPECT TO THE ACCURACY OR COMPLETENESS OF THE CONTENTS OF THIS PUBLICATION AND RESERVES THE RIGHT TO MAKE CHANGES TO SPECIFICATIONS AND PRODUCT DESCRIPTIONS AT ANY TIME WITHOUT NOTICE. NO LICENSE, WHETHER EXPRESS, IMPLIED, ARISING BY ESTOPPEL OR OTHERWISE, TO ANY INTELLECTUAL PROPERTY RIGHTS IS GRANTED BY THIS DOCUMENT.

TESTING AND OTHER QUALITY CONTROLS ARE USED TO THE EXTENT NATIONAL DEEMS NECESSARY TO SUPPORT NATIONAL'S PRODUCT WARRANTY. EXCEPT WHERE MANDATED BY GOVERNMENT REQUIREMENTS, TESTING OF ALL PARAMETERS OF EACH PRODUCT IS NOT NECESSARILY PERFORMED. NATIONAL ASSUMES NO LIABILITY FOR APPLICATIONS ASSISTANCE OR BUYER PRODUCT DESIGN. BUYERS ARE RESPONSIBLE FOR THEIR PRODUCTS AND APPLICATIONS USING NATIONAL COMPONENTS. PRIOR TO USING OR DISTRIBUTING ANY PRODUCTS THAT INCLUDE NATIONAL COMPONENTS, BUYERS SHOULD PROVIDE ADEQUATE DESIGN, TESTING AND OPERATING SAFEGUARDS.

EXCEPT AS PROVIDED IN NATIONAL'S TERMS AND CONDITIONS OF SALE FOR SUCH PRODUCTS, NATIONAL ASSUMES NO LIABILITY WHATSOEVER, AND NATIONAL DISCLAIMS ANY EXPRESS OR IMPLIED WARRANTY RELATING TO THE SALE AND/OR USE OF NATIONAL PRODUCTS INCLUDING LIABILITY OR WARRANTIES RELATING TO FITNESS FOR A PARTICULAR PURPOSE, MERCHANTABILITY, OR INFRINGEMENT OF ANY PATENT, COPYRIGHT OR OTHER INTELLECTUAL PROPERTY RIGHT.

LIFE SUPPORT POLICY

NATIONAL'S PRODUCTS ARE NOT AUTHORIZED FOR USE AS CRITICAL COMPONENTS IN LIFE SUPPORT DEVICES OR SYSTEMS WITHOUT THE EXPRESS PRIOR WRITTEN APPROVAL OF THE CHIEF EXECUTIVE OFFICER AND GENERAL COUNSEL OF NATIONAL SEMICONDUCTOR CORPORATION. As used herein:

Life support devices or systems are devices which (a) are intended for surgical implant into the body, or (b) support or sustain life and whose failure to perform when properly used in accordance with instructions for use provided in the labeling can be reasonably expected to result in a significant injury to the user. A critical component is any component in a life support device or system whose failure to perform can be reasonably expected to cause the failure of the life support device or system or to affect its safety or effectiveness.

National Semiconductor and the National Semiconductor logo are registered trademarks of National Semiconductor Corporation. All other brand or product names may be trademarks or registered trademarks of their respective holders.

Copyright© 2010 National Semiconductor Corporation

For the most current product information visit us at www.national.com



National Semiconductor Americas Technical Support Center
 Email: support@nsc.com
 Tel: 1-800-272-9959

National Semiconductor Europe Technical Support Center
 Email: europe.support@nsc.com

National Semiconductor Asia Pacific Technical Support Center
 Email: ap.support@nsc.com

National Semiconductor Japan Technical Support Center
 Email: jpn.feedback@nsc.com