



# STP16DPS05

## Low voltage 16-bit constant current LED sink driver with outputs error detection

### Features

- Low voltage power supply down to 3 V
- 16 constant current output channels
- Adjustable output current through external resistor
- Short and open output error detection
- Serial data IN/Parallel data OUT
- 3.3 V micro driver-able
- Output current: 20-85 mA
- 30 MHz clock frequency
- Available in high thermal efficiency TSSOP exposed pad
- ESD protection 2.0 kV HBM, 200 V MM

### Description

The STP16DPS05 is a monolithic, low voltage, low current power 16-bit shift register designed for LED panel displays. The device contains a 16-bit serial-in, parallel-out shift register that feeds a 16-bit D-type storage register. In the output stage, sixteen regulated current sources were designed to provide 5-100 mA constant current to drive the LEDs.

The STP16DP05 features open and short LED detections on the outputs. The STP16DP05 is backward compatible with STP16C/L596. The detection circuit checks 3 different conditions that can occur on the output line: short to GND, short to  $V_O$  or open line.

**Table 1. Device summary**

Order codes	Package	Packaging
STP16DPS05MTR	SO-24 (tape and reel)	1000 parts per reel
STP16DPS05TTR	TSSOP24 (tape and reel)	2500 parts per reel
STP16DPS05XTTR	TSSOP24 exposed pad (tape and reel)	2500 parts per reel
STP16DP05PTR	QSOP-24	2500 parts per reel

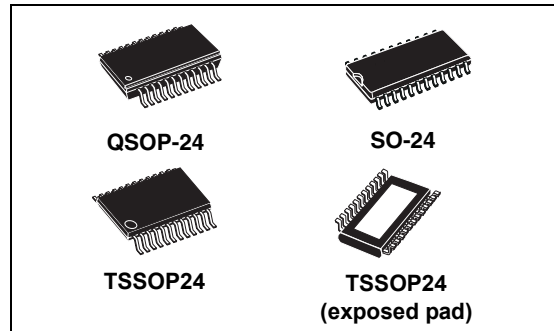

The data detection results are loaded in the shift register and shifted out via the serial line output.

The detection functionality is implemented without increasing the pin count number, through a secondary function of the LATCH and output enable pin (DM1 and DM2 respectively), a dedicated logic sequence allows the device to enter or leave from detection mode. Through an external resistor, users can adjust the STP16DPS05 output current, controlling in this way the light intensity of LEDs, in addition, user can adjust LED's brightness intensity from 0% to 100% via  $\overline{OE}/DM2$  pin.

The STP16DPS05 guarantees a 20 V output driving capability, allowing users to connect more LEDs in series. The high clock frequency, 30 MHz, makes the device suitable for high data rate transmission. The 3.3 V voltage supply is well useful for applications that interface any 3.3V micro. Compared with a standard TSSOP package, the TSSOP exposed pad increases heat dissipation capability by a 2.5 factor.

# Contents

<b>1</b>	<b>Summary description</b> .....	<b>3</b>
1.1	Pin connection and description .....	3
<b>2</b>	<b>Electrical ratings</b> .....	<b>4</b>
2.1	Absolute maximum ratings .....	4
2.2	Thermal data .....	4
2.3	Recommended operating conditions .....	5
<b>3</b>	<b>Electrical characteristics</b> .....	<b>6</b>
<b>4</b>	<b>Equivalent circuit and outputs</b> .....	<b>8</b>
<b>5</b>	<b>Timing diagrams</b> .....	<b>10</b>
<b>6</b>	<b>Typical characteristics</b> .....	<b>13</b>
<b>7</b>	<b>Detection mode functionality</b> .....	<b>16</b>
7.1	Phase one: “entering in detection mode” .....	16
7.2	Phase two: “error detection” .....	17
7.3	Phase three: “resuming to normal mode” .....	19
7.4	Error detection conditions .....	19
7.5	Auto power-saving .....	22
<b>8</b>	<b>Package mechanical data</b> .....	<b>25</b>
<b>9</b>	<b>Revision history</b> .....	<b>33</b>

# 1 Summary description

Table 2. Typical current accuracy

Output voltage	Current accuracy		Output current	V <sub>DD</sub>	Temperature
	Between bits	Between ICs			
≥ 1.3 V	±1.5%	±5%	20 to 100 mA	3.3 V to 5 V	25 °C

## 1.1 Pin connection and description

Figure 1. Pin connection

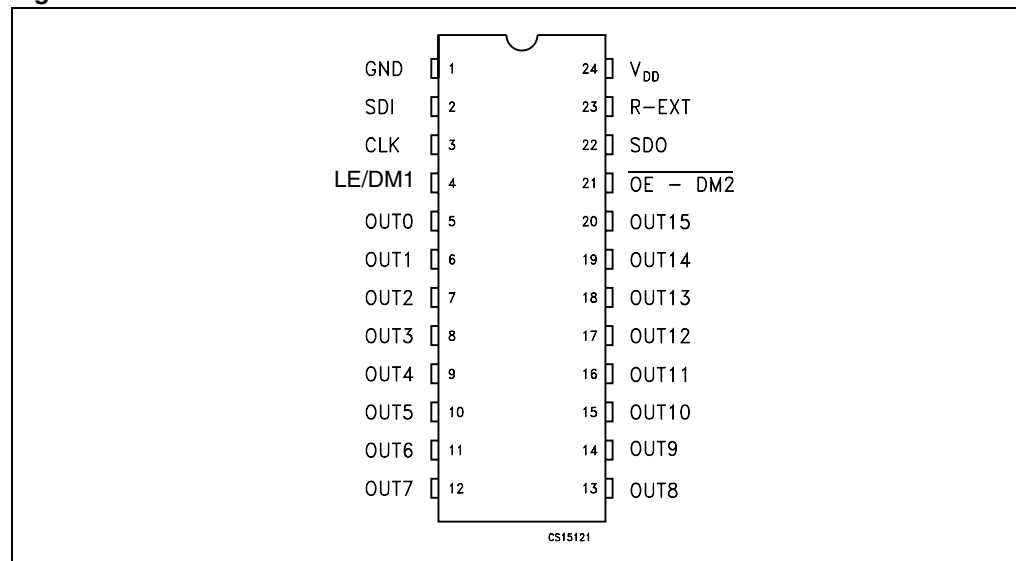

*Note:* The exposed pad should be electrically connected to a metal land electrically isolated or connected to ground.

Table 3. Pin description

Pin n°	Symbol	Name and function
1	GND	Ground terminal
2	SDI	Serial data input terminal
3	CLK	Clock input terminal
4	LE/DM1	Latch input terminal - detect mode 1 (see operation principle)
5-20	$\overline{\text{OUT 0-15}}$	Output terminal
21	$\overline{\text{OE/DM2}}$	Input terminal of output enable (active low) - detect mode 1 (see operation principle)
22	SDO	Serial data out terminal
23	R-EXT	Input terminal of an external resistor for constant current programming
24	V <sub>DD</sub>	Supply voltage terminal

## 2 Electrical ratings

### 2.1 Absolute maximum ratings

Stressing the device above the rating listed in the [Table 4](#) may cause permanent damage to the device. These are stress ratings only and operation of the device at these or any other conditions above those indicated in the operating sections of this specification is not implied. Exposure to absolute maximum rating conditions for extended periods may affect device reliability.

**Table 4. Absolute maximum ratings**

Symbol	Parameter	Value	Unit
$V_{DD}$	Supply voltage	0 to 7	V
$V_O$	Output voltage	-0.5 to 20	V
$I_O$	Output current	100	mA
$V_I$	Input voltage	-0.4 to $V_{DD}$	V
$I_{GND}$	GND terminal current	1600	mA
$f_{CLK}$	Clock frequency	50	MHz
$T_J$	Junction temperature range <sup>(1)</sup>	-40 to +170	°C

1. Such absolute value is achieved according the thermal shutdown

### 2.2 Thermal data

**Table 5. Thermal data**

Symbol	Parameter	Value	Unit	
$T_{OPR}$	Operating temperature range	-40 to +125	°C	
$T_{STG}$	Storage temperature range	-55 to +150	°C	
$R_{thJA}$	Thermal resistance junction-ambient <sup>(1)</sup>	SO-24	42.7	°C/W
		TSSOP24	55	°C/W
		TSSOP24 <sup>(2)</sup> exposed pad	37.5	°C/W
		QSOP-24	55	°C/W

1. According with JEDEC JESD51-7

2. The exposed pad should be soldered directly to the PCB to realize the thermal benefits.

## 2.3 Recommended operating conditions

**Table 6. Recommended operating conditions**

Symbol	Parameter	Test conditions	Min.	Typ.	Max.	Unit
$V_{DD}$	Supply voltage		3.0	-	5.5	V
$V_O$	Output voltage			-	20	V
$I_O$	Output current	OUTn	5	-	100	mA
$I_{OH}$	Output current	SERIAL-OUT		-	+1	mA
$I_{OL}$	Output current	SERIAL-OUT		-	-1	mA
$V_{IH}$	Input voltage		$0.7V_{DD}$	-	$V_{DD}+0.3$	V
$V_{IL}$	Input voltage		-0.3	-	$0.3 V_{DD}$	V
$t_{wLAT}$	LE/DM1 pulse width	$V_{DD} = 3.0 \text{ V to } 5.0 \text{ V}$	6	-		ns
$t_{wCLK}$	CLK pulse width		8	-		ns
$t_{wEN}$	$\overline{OE}/DM2$ pulse width		100	-		ns
$t_{SETUP(D)}$	Setup time for DATA		10	-		ns
$t_{HOLD(D)}$	Hold time for DATA		5	-		ns
$t_{SETUP(L)}$	Setup time for LATCH		10	-		ns
$f_{CLK}$	Clock frequency		Cascade operation <sup>(1)</sup>		-	30

1. If the device is connected in cascade, it may not be possible to achieve the maximum data transfer. Please consider the timings carefully.

### 3 Electrical characteristics

$V_{DD} = 5\text{ V}$ ,  $T = 25\text{ °C}$ , unless otherwise specified

**Table 7. Electrical characteristics**

Symbol	Parameter	Test conditions	Min.	Typ.	Max.	Unit
$V_{IH}$	Input voltage high level		$0.7V_{DD}$		$V_{DD}$	V
$V_{IL}$	Input voltage low level		GND		$0.3V_{DD}$	V
$I_{OH}$	Output leakage current	$V_{OH} = 20\text{ V}$			1	$\mu\text{A}$
$V_{OL}$	Output voltage (Serial-OUT)	$I_{OL} = 1\text{ mA}$			0.4	V
$V_{OH}$	Output voltage (Serial-OUT)	$I_{OH} = -1\text{ mA}$	$V_{OH} - V_{DD} = -0.4\text{ V}$			V
$I_{OL1}$	Output current	$V_O = 0.3\text{ V}$ , $R_{ext} = 3.9\text{ k}\Omega$	4.25	5	5.75	mA
$I_{OL2}$		$V_O = 0.3\text{ V}$ , $R_{ext} = 970\ \Omega$	19	20	21	
$I_{OL3}$		$V_O = 1.3\text{ V}$ , $R_{ext} = 190\ \Omega$	96	100	104	
$\Delta I_{OL1}$	Output current error between bit (all output ON)	$V_O = 0.3\text{ V}$ , $R_{EXT} = 3.9\text{ k}\Omega$		$\pm 5$	$\pm 8$	%
$\Delta I_{OL2}$		$V_O = 0.3\text{ V}$ , $R_{EXT} = 970\ \Omega$		$\pm 1.5$	$\pm 3$	
$\Delta I_{OL3}$		$V_O = 1.3\text{ V}$ , $R_{EXT} = 190\ \Omega$		$\pm 1.2$	$\pm 3$	
$R_{SIN(up)}$	Pull-up resistor		150	300	600	$\text{K}\Omega$
$R_{SIN(down)}$	Pull-down resistor		100	200	400	$\text{K}\Omega$
$I_{DD(OFF1)}$	Supply current (OFF)	$R_{EXT} = 970$ OUT 0 to 15 = OFF		5	6	mA
$I_{DD(OFF2)}$		$R_{EXT} = 240$ OUT 0 to 15 = OFF		13	14	
$I_{DD(ON1)}$	Supply current (ON)	$R_{EXT} = 970$ OUT 0 to 15 = ON		6	7	
$I_{DD(ON2)}$		$R_{EXT} = 240$ OUT 0 to 15 = ON		13.5	14.5	
Thermal	Thermal protection <sup>(1)</sup>			170		$^{\circ}\text{C}$

1. Guaranteed by design (not tested)  
The thermal protection switches OFF only the outputs current

$V_{DD} = 5\text{ V}$ ,  $T = 25\text{ }^{\circ}\text{C}$ , unless otherwise specified

**Table 8. Switching characteristics**

Symbol	Parameter	Test conditions	Min.	Typ.	Max.	Unit	
$t_{PLH1}$	Propagation delay time, $\overline{\text{CLK}}\text{-OUTn}$ , $\text{LE}/\text{DM1} = \text{H}$ , $\overline{\text{OE}}/\text{DM2} = \text{L}$	$V_{IH} = V_{DD}$ $V_{IL} = \text{GND}$ $I_O = 20\text{ mA}$ $R_{EXT} = 1\text{ K}\Omega$ $C_L = 10\text{ pF}$ $V_L = 3.0\text{ V}$ $R_L = 60\text{ }\Omega$	$V_{DD} = 3.3\text{ V}$	-	40 to 44	44	ns
			$V_{DD} = 5\text{ V}$	-	20 to 44	44	
$t_{PLH2}$	Propagation delay time, $\overline{\text{LE}}/\text{DM1}\text{-OUTn}$ , $\overline{\text{OE}}/\text{DM2} = \text{L}$		$V_{DD} = 3.3\text{ V}$	-	51	77	ns
			$V_{DD} = 5\text{ V}$	-	32	47	
$t_{PLH3}$	Propagation delay time, $\overline{\text{OE}}/\text{DM2}\text{-OUTn}$ , $\text{LE}/\text{DM1} = \text{H}$		$V_{DD} = 3.3\text{ V}$	-	49 to 57	57 to 77	ns
			$V_{DD} = 5\text{ V}$	-	27 to 32	32 to 41	
$t_{PLH}$	Propagation delay time, $\text{CLK}\text{-SDO}$		$V_{DD} = 3.3\text{ V}$	-	21.5 to 22	32	ns
			$V_{DD} = 5\text{ V}$	-	14.5 to 15	21.5	
$t_{PHL1}$	Propagation delay time, $\text{CLK}\text{-OUTn}$ , $\text{LE}/\text{DM1} = \text{H}$ , $\overline{\text{OE}}/\text{DM2} = \text{L}$		$V_{DD} = 3.3\text{ V}$	-	15 to 18	25	ns
			$V_{DD} = 5\text{ V}$	-	11 to 13	14.5 to 16	
$t_{PHL2}$	Propagation delay time, $\overline{\text{LE}}/\text{DM1}\text{-OUTn}$ , $\overline{\text{OE}}/\text{DM2} = \text{L}$		$V_{DD} = 3.3\text{ V}$	-	13 to 18	18 to 25	ns
			$V_{DD} = 5\text{ V}$	-	9 to 12	12.5 to 15	
$t_{PHL3}$	Propagation delay time, $\overline{\text{OE}}/\text{DM2}\text{-OUTn}$ , $\text{LE}/\text{DM1} = \text{H}$		$V_{DD} = 3.3\text{ V}$	-	11.5 to 12	12 to 18	ns
			$V_{DD} = 5\text{ V}$	-	8.5 to 10	9.7 to 12	
$t_{PHL}$	Propagation delay time, $\text{CLK}\text{-SDO}$	$V_{DD} = 3.3\text{ V}$	-	25.5	38	ns	
		$V_{DD} = 5\text{ V}$	-	17.5 to 20.5	25		
$t_{ON}$	Output rise time 10~90% of voltage waveform	$V_{DD} = 3.3\text{ V}$	-	34 to 20	24 to 53.5	ns	
		$V_{DD} = 5\text{ V}$	-	12.5 to 9	9 to 18.5		
$t_{OFF}$	Output fall time 90~10% of voltage waveform	$V_{DD} = 3.3\text{ V}$	-	5.5 to 3.3	3.3 to 8.5	ns	
		$V_{DD} = 5\text{ V}$	-	4.5 to 2.8	2.8 to 6.5		
$t_r$	CLK rise time <sup>(1)</sup>		-		5000	ns	
$t_f$	CLK fall time <sup>(1)</sup>		-		5000	ns	

1. In order to achieve high cascade data transfer, please consider  $t_r/t_f$  timings carefully.

## 4 Equivalent circuit and outputs

Figure 2.  $\overline{\text{OE/DM2}}$  terminal

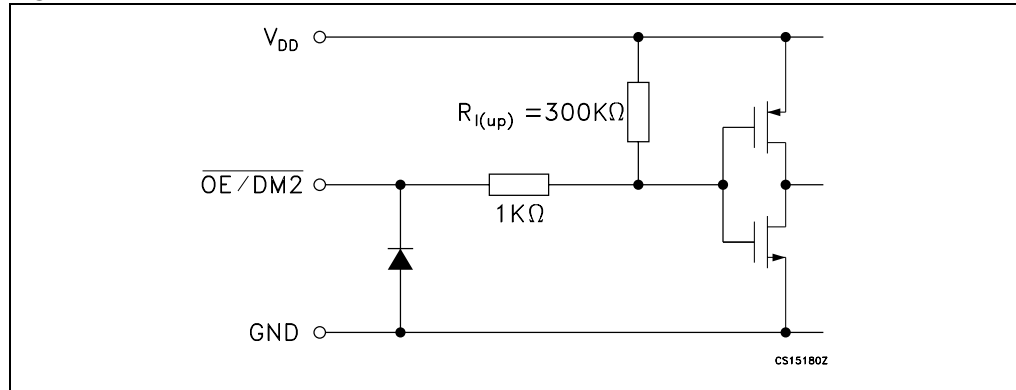

Figure 3. LE/DM1 terminal

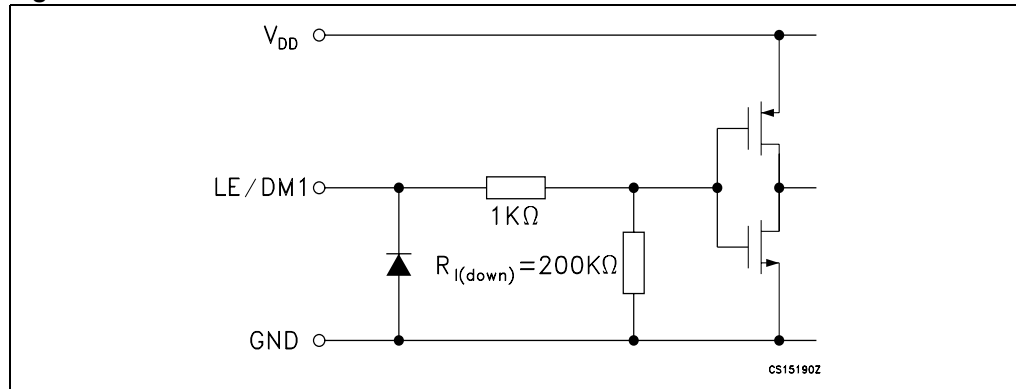

Figure 4. CLK, SDI terminal

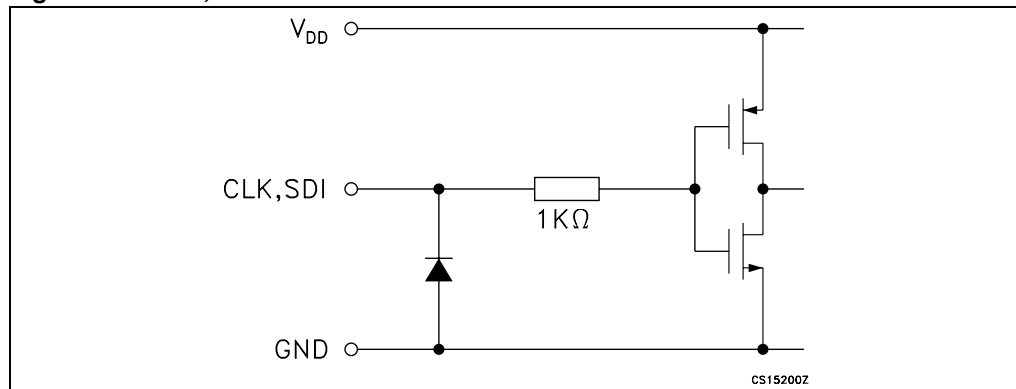



Figure 5. SDO terminal

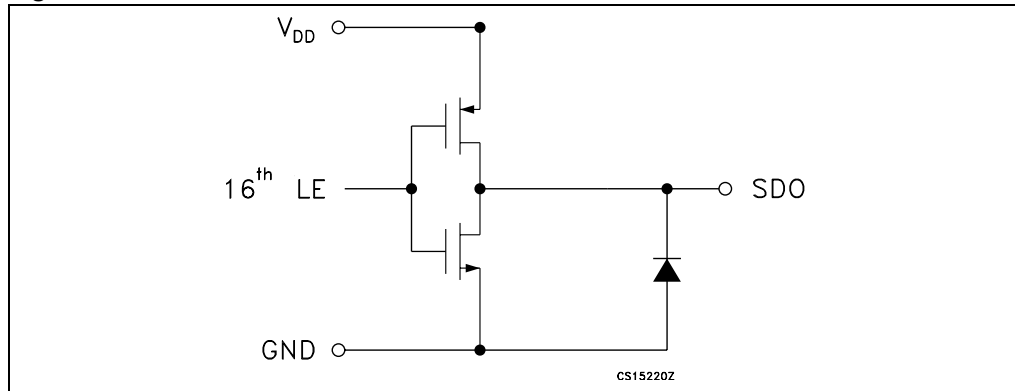
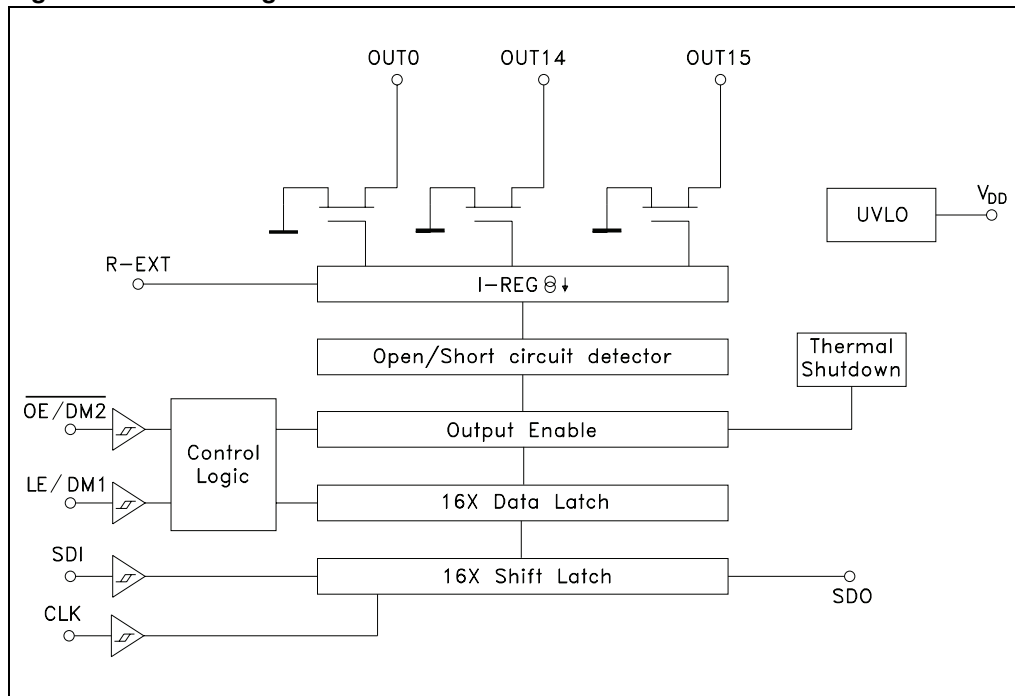

Figure 6. Block diagram



## 5 Timing diagrams

Table 9. Truth table

CLOCK	LE/DM1	OE/DM2	SERIAL-IN	OUT0 ..... OUT7 ..... OUT15	SDO
	H	L	Dn	Dn ..... Dn - 7 ..... Dn -15	Dn - 15
	L	L	Dn + 1	No change	Dn - 14
	H	L	Dn + 2	Dn + 2 ..... Dn - 5 ..... Dn -13	Dn - 13
	X	L	Dn + 3	Dn + 2 ..... Dn - 5 ..... Dn -13	Dn - 13
	X	H	Dn + 3	OFF	Dn - 13

Note:  $OUTn = ON$  when  $Dn = H$   $OUTn = OFF$  when  $Dn = L$

Figure 7. Timing diagram

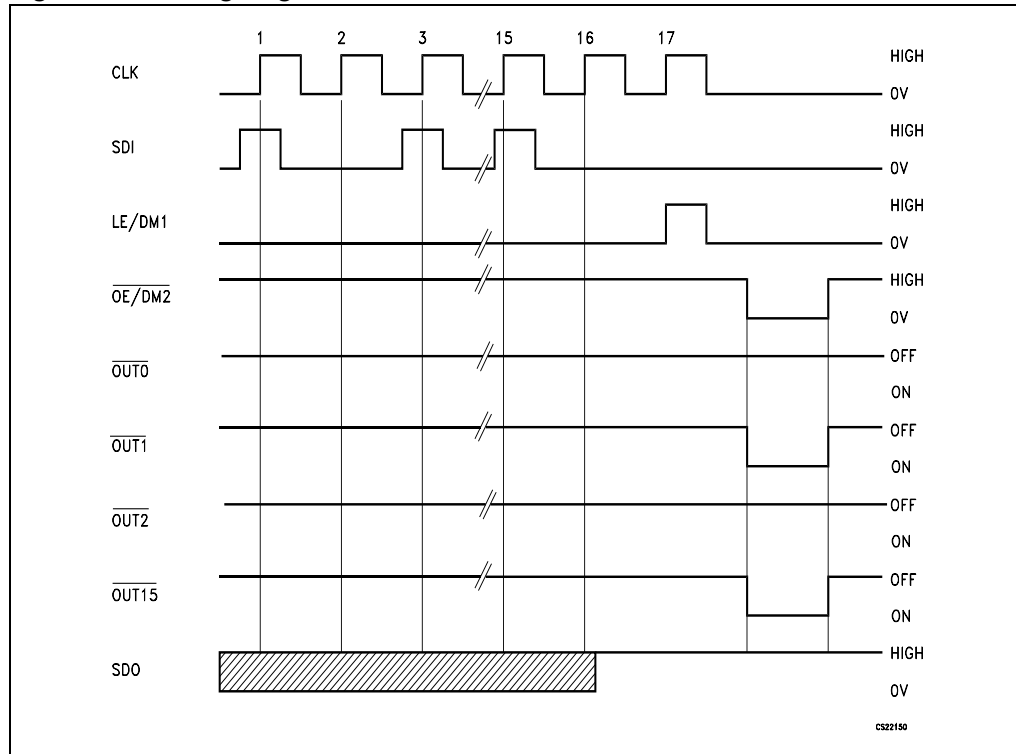

- Note:
- 1 Latch and output enable are level sensitive and ARE NOT synchronized with rising-or-falling edge of CLK signal.
  - 2 When LE/DM1 terminal is low level, the latch circuits hold previous set of data
  - 3 When LE/DM1 terminal is high level, the latch circuits refresh new set of data from SDI chain.
  - 4 When OE/DM2 terminal is at low level, the output terminals - Out0 to Out15 respond to data in the latch circuits, either '1' for ON or '0' for OFF
  - 5 When OE/DM2 terminal is at high level, all output terminals will be switched OFF.

Figure 8. Clock, serial-in, serial-out

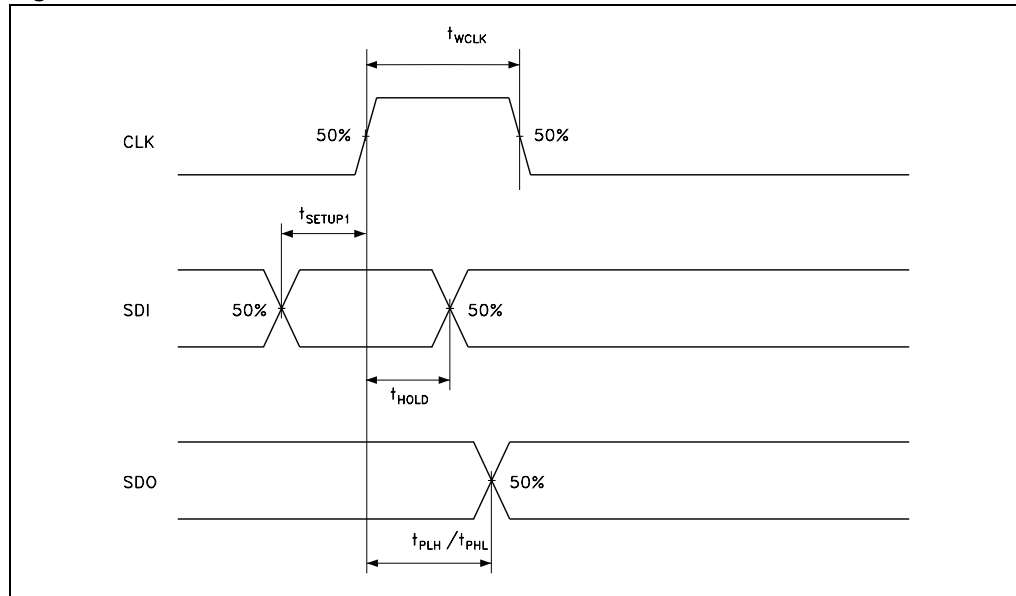

Figure 9. Clock, serial-in, latch, enable, outputs

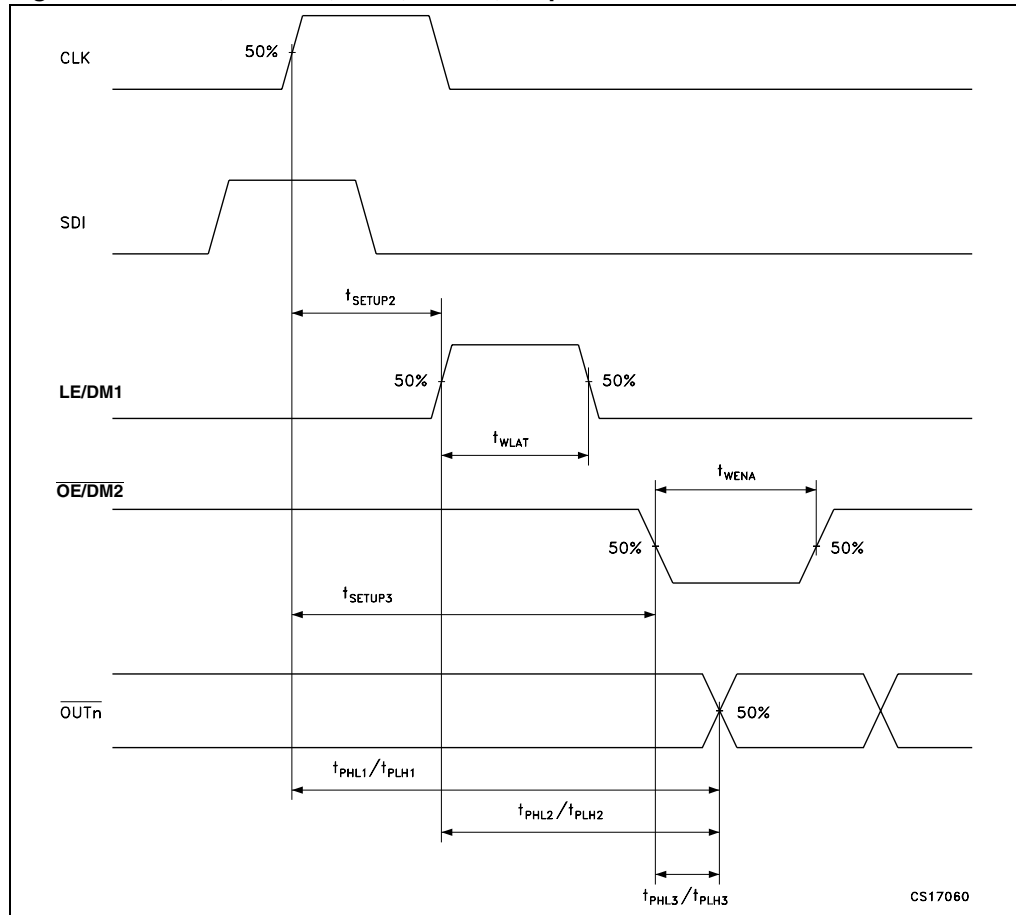
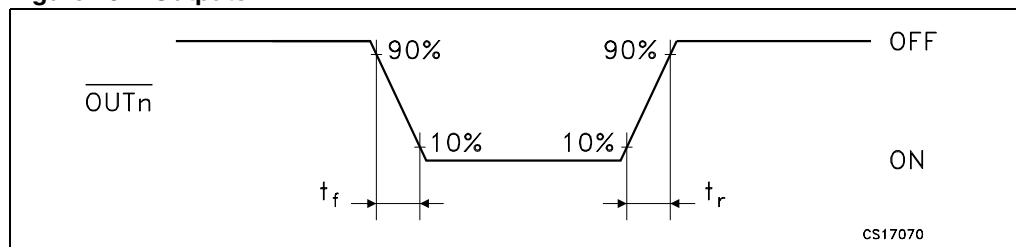

Figure 10. Outputs



## 6 Typical characteristics

Figure 11. Output current- $R_{EXT}$  resistor

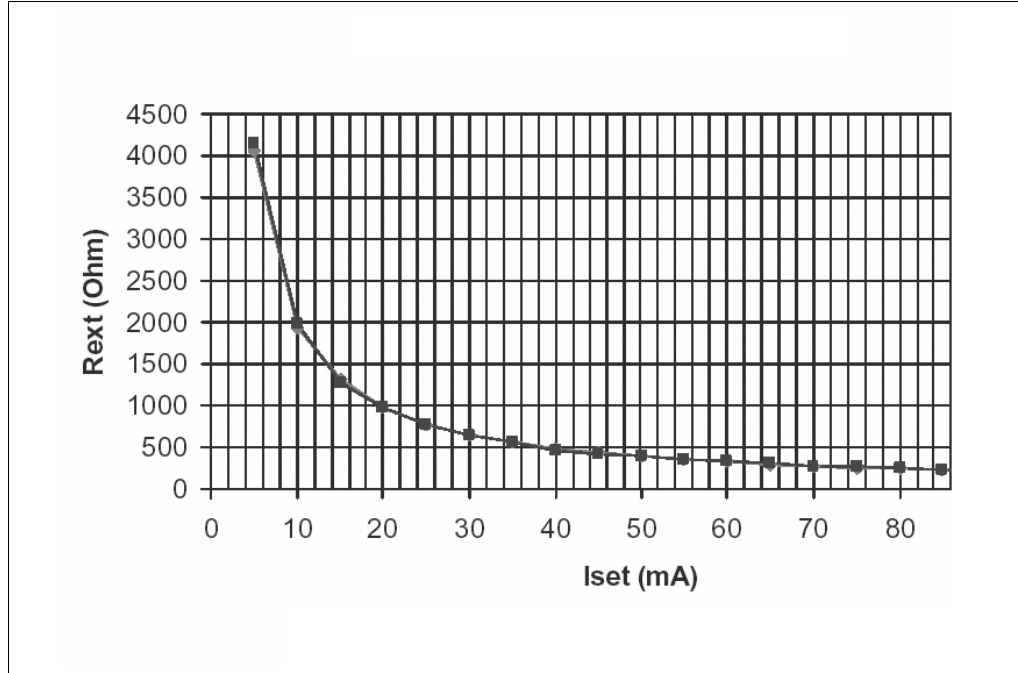

Table 10. Output current- $R_{EXT}$  resistor

$R_{ext}$ ( $\Omega$ )	Output current (mA)
976	20
780	25
652	30
560	35
488	40
433	45
389	50
354	55
325	60
300	65
278	70
259	75
241	80
229	85

Conditions:  
 Temperature = 25 °C,  $V_{DD} = 3.3\text{ V}; 5.0\text{ V}$ ,  $I_{SET} = 3\text{ mA}; 5\text{ mA}; 10\text{ mA}; 20\text{ mA}; 50\text{ mA}; 80\text{ mA}$ .

Figure 12.  $I_{SET}$  vs drop out voltage ( $V_{drop}$ )

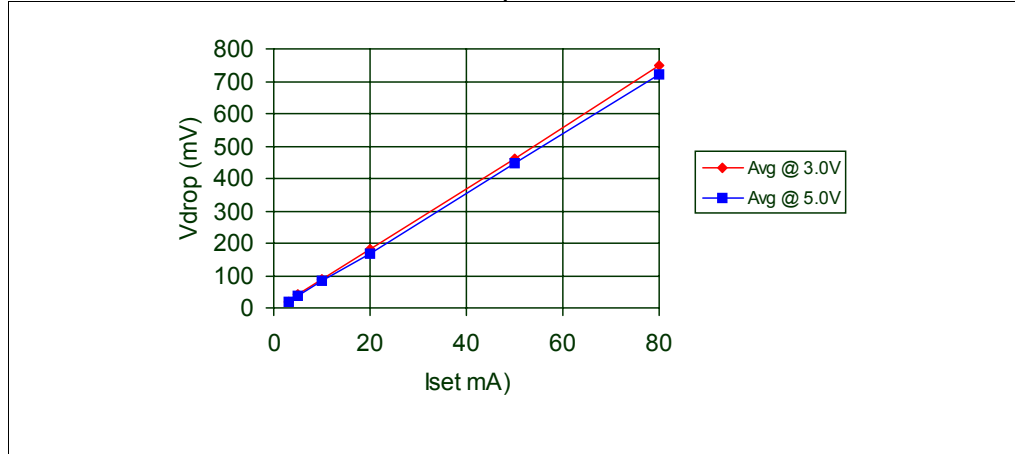
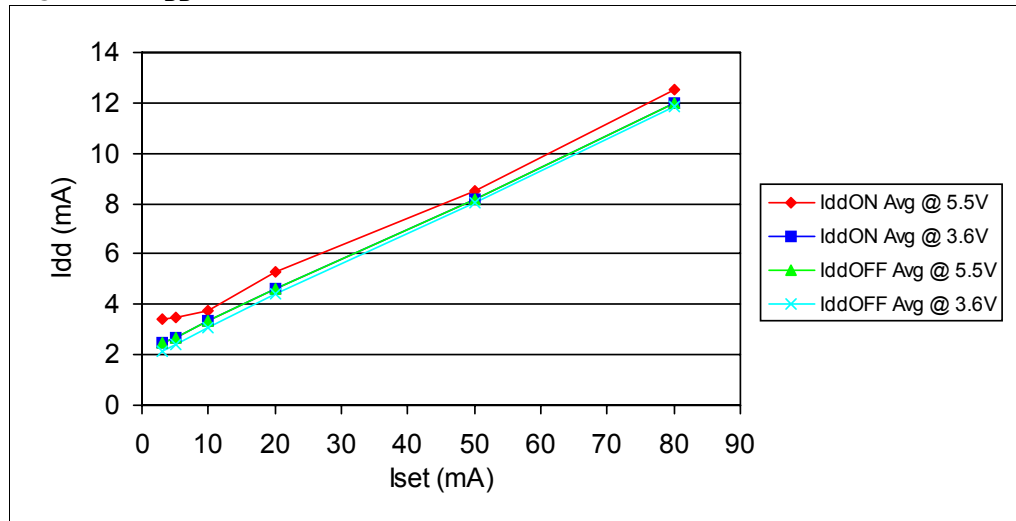

Table 11.  $I_{SET}$  vs drop out voltage ( $V_{drop}$ )

$I_{out}$ (mA)	Avg @ 3.0 V	Avg @ 5.0 V
3	19.33	22.66
5	36.67	40.33
10	77.33	80
20	158.67	157.33
50	406	406
80	692	668

Figure 13.  $I_{DD}$  ON/OFF

## 7 Detection mode functionality

### 7.1 Phase one: “entering in detection mode“

From the “normal mode” condition the device can switch to the “error mode” by a logic sequence on the  $\overline{OE}/DM2$  and LE/DM1 pins as showed in the following table and diagram:

**Table 12. Entering in detection truth table**

CLK	1°	2°	3°	4°	5°
$\overline{OE}/DM2$	H	L	H	H	H
LE/DM1	L	L	L	H	L

**Figure 14. Entering in detection timing diagram**

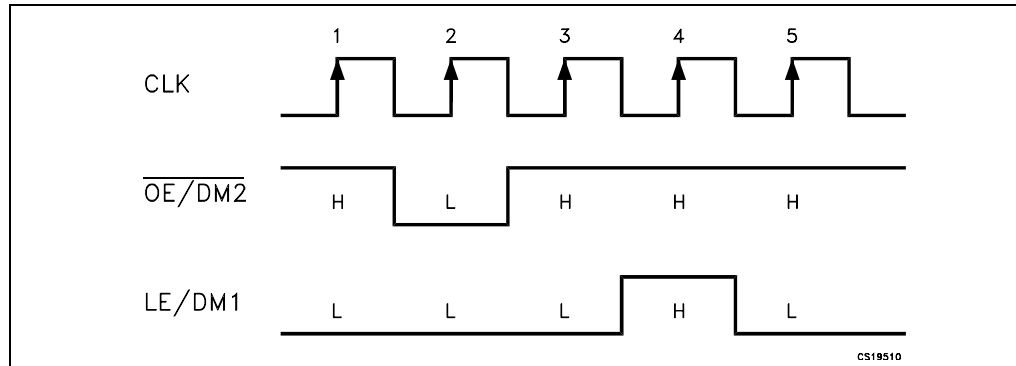

After these five CLK cycles the device goes into the “error detection mode” and at the 6<sup>th</sup> rise front of CLK the SDI data are ready for the sampling.



## 7.2 Phase two: “error detection”

The 16 data bits must be set “1” in order to set ON all the outputs during the detection. The data are latched by LE/DM1 and after that the outputs are ready for the detection process. When the microcontroller switches the  $\overline{OE/DM2}$  to LOW, the device drives the LEDs in order to analyze if an OPEN or SHORT condition has occurred.

Figure 15. Detection diagram

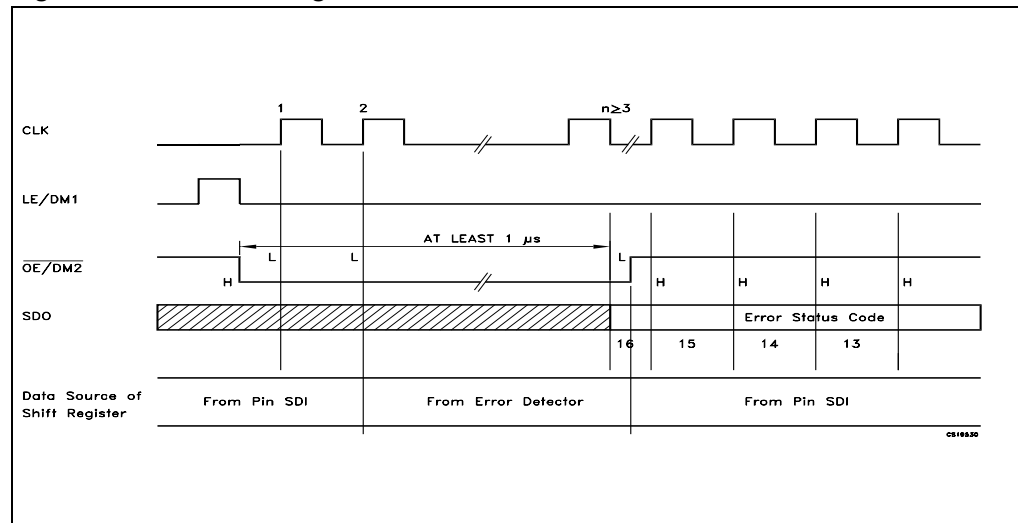

The LEDs status will be detected at least in 1 microsecond and after this time the microcontroller sets  $\overline{OE/DM2}$  in HIGH state and the output data detection result will go to the microprocessor via SDO.

Detection mode and normal mode use both the same format data. As soon as all the detection data bits are available on the serial line, the device may go back to normal mode of operation. To re-detect the status the device must go back in normal mode and re-entering in error detection mode.

Figure 16. Timing example for open and/or short detection

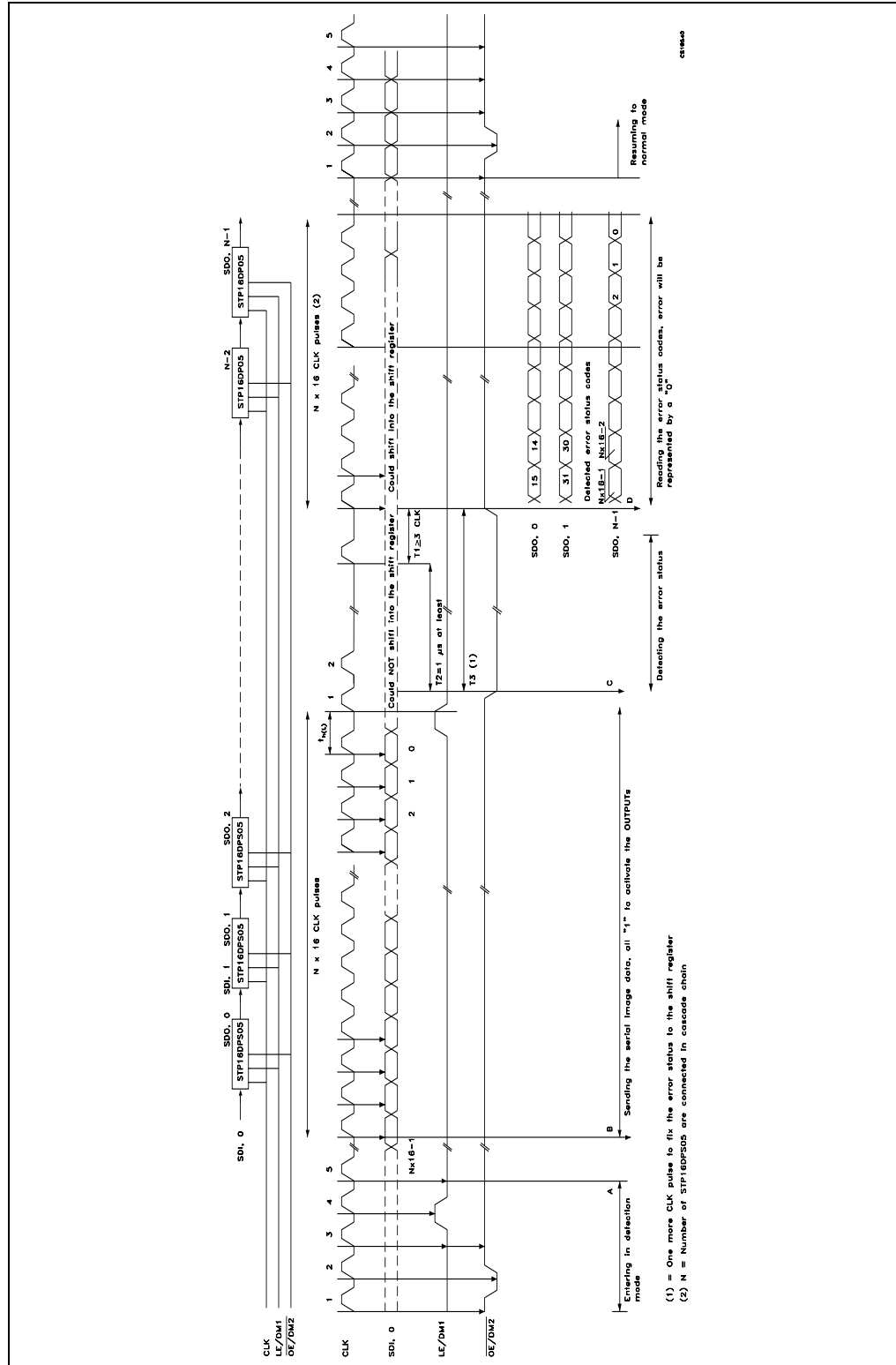

(1) = One more CLK pulse to fix the error status to the shift register.  
 (2) N = Number of STP16DPS05 are connected in cascade chain

### 7.3 Phase three: “resuming to normal mode”

The sequence for re-entering in normal mode is showed in the following table and diagram:

**Figure 17. Resuming to normal mode timing diagram**

CLK	1°	2°	3°	4°	5°
$\overline{\text{OE/DM2}}$	H	L	H	H	H
LE/DM1	L	L	L	L	L

*Note:* For proper device operation the “Entering in detection” sequence must be follow by a “resume mode” sequence, it is not possible to insert consecutive equal sequence.

### 7.4 Error detection conditions

$V_{DD} = 3.3$  to 5 V temperature range -40 to 125 °C

**Table 13. Detection conditions**

<b>SW-1 or SW-3b</b>	Open line or output short to GND detected	$\implies I_{ODEC} \leq 0.5 \times I_O$	No error detected	$\implies I_{ODEC} \geq 0.5 \times I_O$
<b>SW-2 or SW-3a</b>	Short on LED or short to V-LED detected	$\implies V_O \geq 2.4$ V	No error detected	$\implies V_O \leq 2.2$ V

*Note:* Where:  $I_O$  = the output current programmed by the  $R_{EXT}$ ,  $I_{ODEC}$  = the detected output current in detection mode

**Figure 18. Detection circuit**

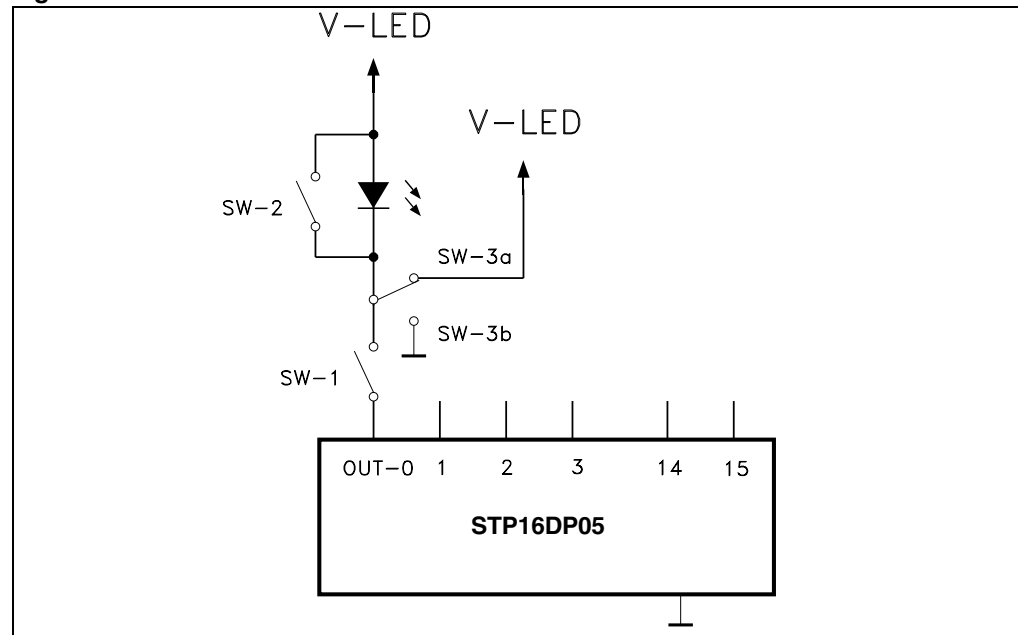
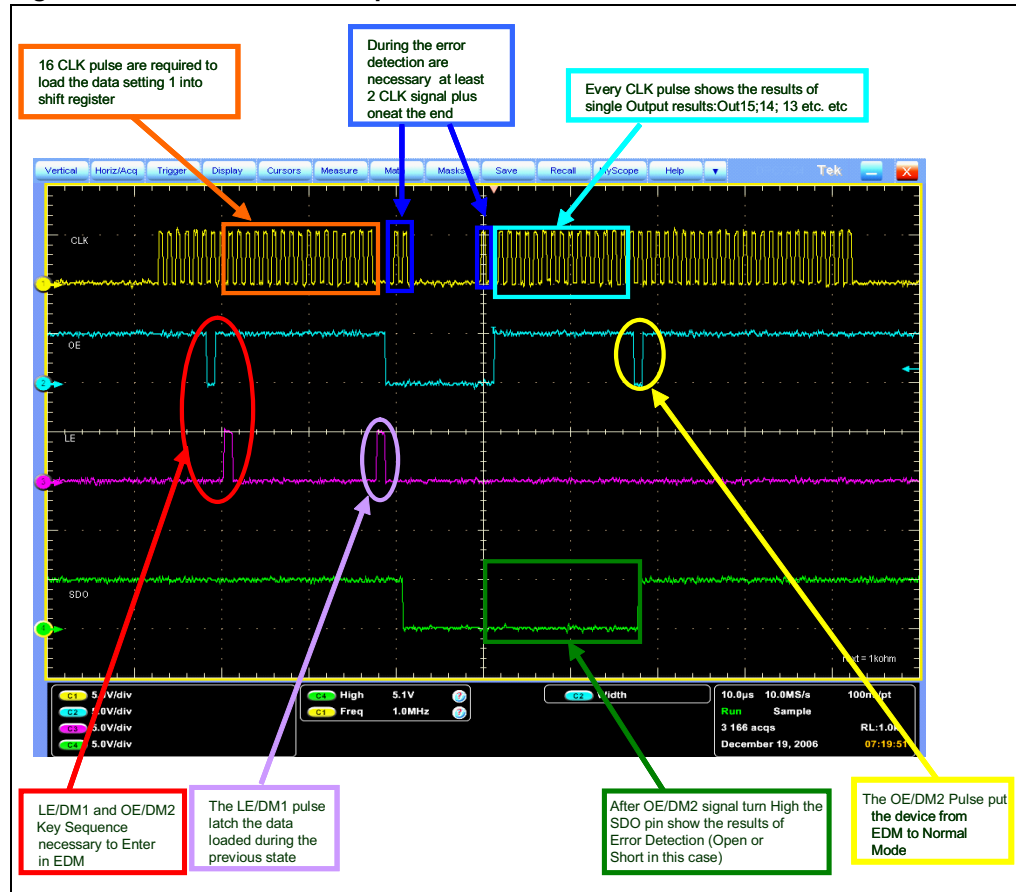
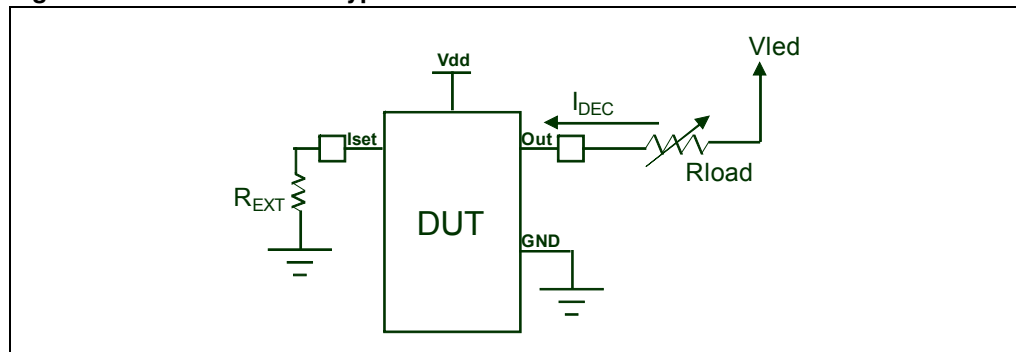

Figure 19. Error detection sequence



Typical schematic used to perform the error detection:

**Figure 20. Error detection typical schematic**



Using the follow formula is possible measure the Iodec

$$I_{ODEC} = (V_{led} - V_{load}) / R_{load}$$

The tables below shows the  $I_{ODEC \text{ average}}$  value at 3.3 V and 5.0 V of power supply voltage.

The  $I_{ODEC}$  is the current value recognized by the devices output open error detection

**Table 14.  $I_{ODEC}$  average value at 3.3 V**

Vdd (V)	Iset (mA)	Rext ( $\Omega$ )	Iout AVG (mA)
3.3	5	4270	2.097
	10	2056	6.79
	20	1006	10.46
	50	382	26.92
	80	251	35.03

**Table 15.  $I_{ODEC}$  average value at 5 V**

Vdd (V)	Iset (mA)	Rext ( $\Omega$ )	Iout AVG (mA)
5	5	4270	1.98
	10	2056	6.09
	20	1006	9.67
	50	382	25.54
	80	251	38.9

## 7.5 Auto power-saving

The auto power-saving feature minimizes the quiescent current if no active data is detected on the latches and auto powers-up the device as the first active data is latched.

Figure 21. Auto power-saving feature

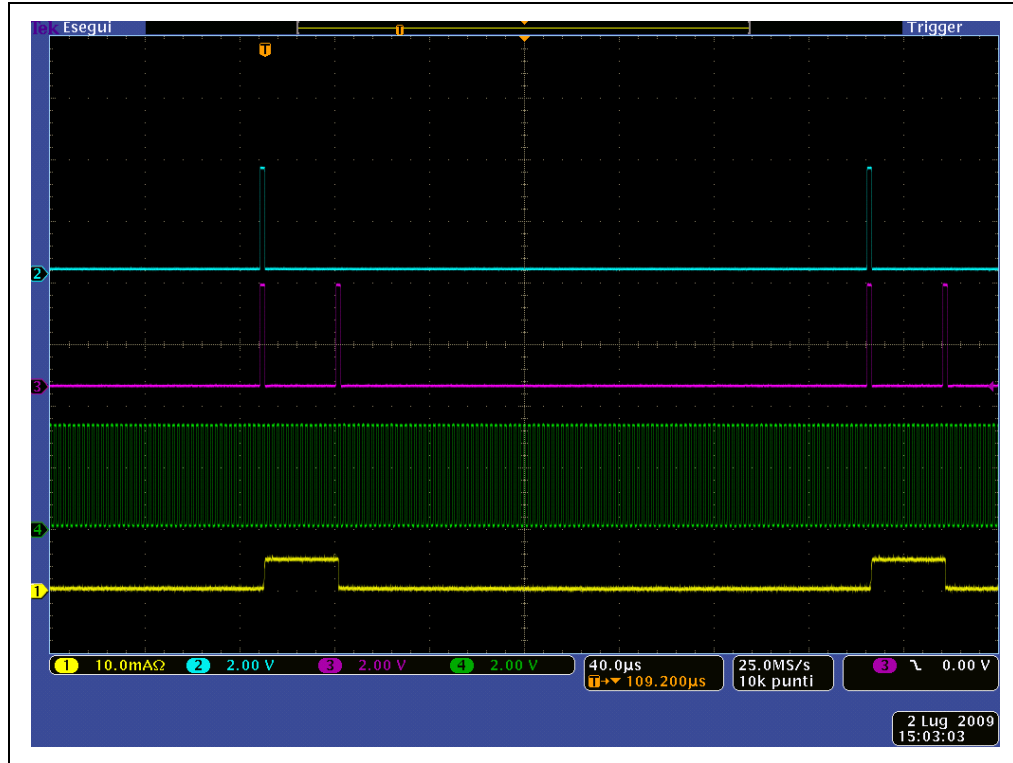

Conditions:

Temp. = 25 °C, Vdd = 3.3 V, Vin = Vdd, VLed = 3.0 V, Iset = 20 mA

Ch1 (Yellow) = IDD, Ch2 (Blue) = SDI, Ch3 (Purple) = LE/DM1, Ch4 (Green) = CLK

I<sub>dd</sub> consumption:

I<sub>dd</sub> (normal operation) = 5.15 mA

I<sub>dd</sub> (shutdown condition) = 163 µA

Figure 22. Delay LE-OUT

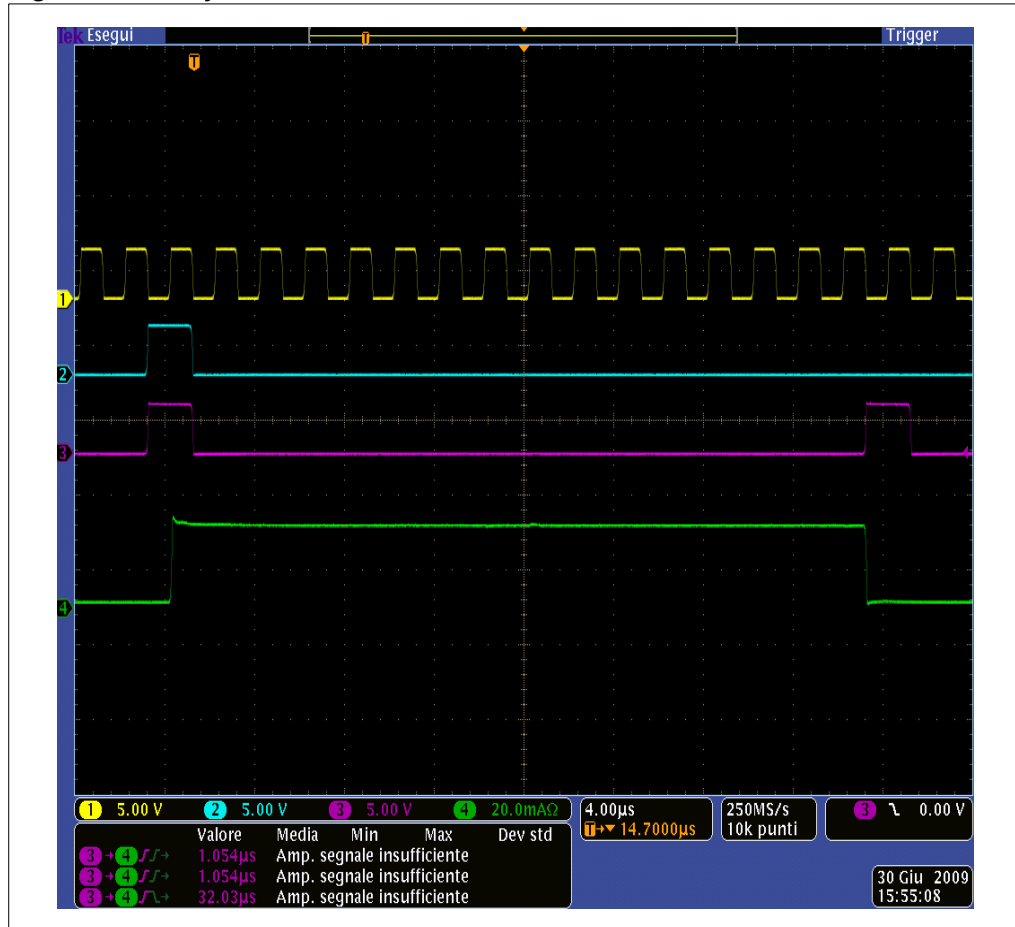

After 16 clock cycles without data change, device will enter in Auto power save mode as expected. Delay TLE-OUT = 1.053 μs

Conditions:

Temp. = 25 °C, Vdd = 3.3 V, Vin = Vdd, VLed = 3.0 V, Iset = 20 mA

Ch1 (Yellow) = CLK, Ch2 (Blue) = SDI, Ch3 (Purple) = LE/DM1, Ch4 (Green) = IOUT

Figure 23. Behaviour auto power saving



*Note:* When the device goes from auto power-saving to normal operating condition, the first output that switches ON shows the  $T_{ON}$  condition as seen in the plot above.

Temp. = 25°C, Vdd = 3.3 V, Vin = Vdd, VLed = 3.0 V, Iset = 20 mA

Ch1 (Yellow) = IDD, Ch2 (Blue) = SDI, Ch3 (Purple) = LE/DM1, Ch4 (Green) = CLK



## 8 Package mechanical data

In order to meet environmental requirements, ST offers these devices in different grades of ECOPACK<sup>®</sup> packages, depending on their level of environmental compliance. ECOPACK<sup>®</sup> specifications, grade definitions and product status are available at: [www.st.com](http://www.st.com). ECOPACK<sup>®</sup> is an ST trademark

**Table 16. QSOP-24 mechanical data**

Dim.	mm.			inch		
	Min.	Typ.	Max.	Min.	Typ.	Max.
A	1.54	1.62	1.73	0.061	0.064	0.068
A1	0.1	0.15	0.25	0.004	0.006	0.010
A2		1.47			0.058	
b	0.31	0.2		0.012	0.008	
c	0.254	0.17		0.010	0.007	
D	8.56	8.66	8.76	0.337	0.341	0.345
E	5.8	6	6.2	0.228	0.236	0.244
E1	3.8	3.91	4.01	0.150	0.154	0.158
e		0.635			0.025	
L	0.4	0.635	0.89	0.016	0.025	0.035
h	0.25	0.33	0.41	0.010	0.013	0.016
<	8°	0°				

Figure 24. QSOP-24 package dimensions

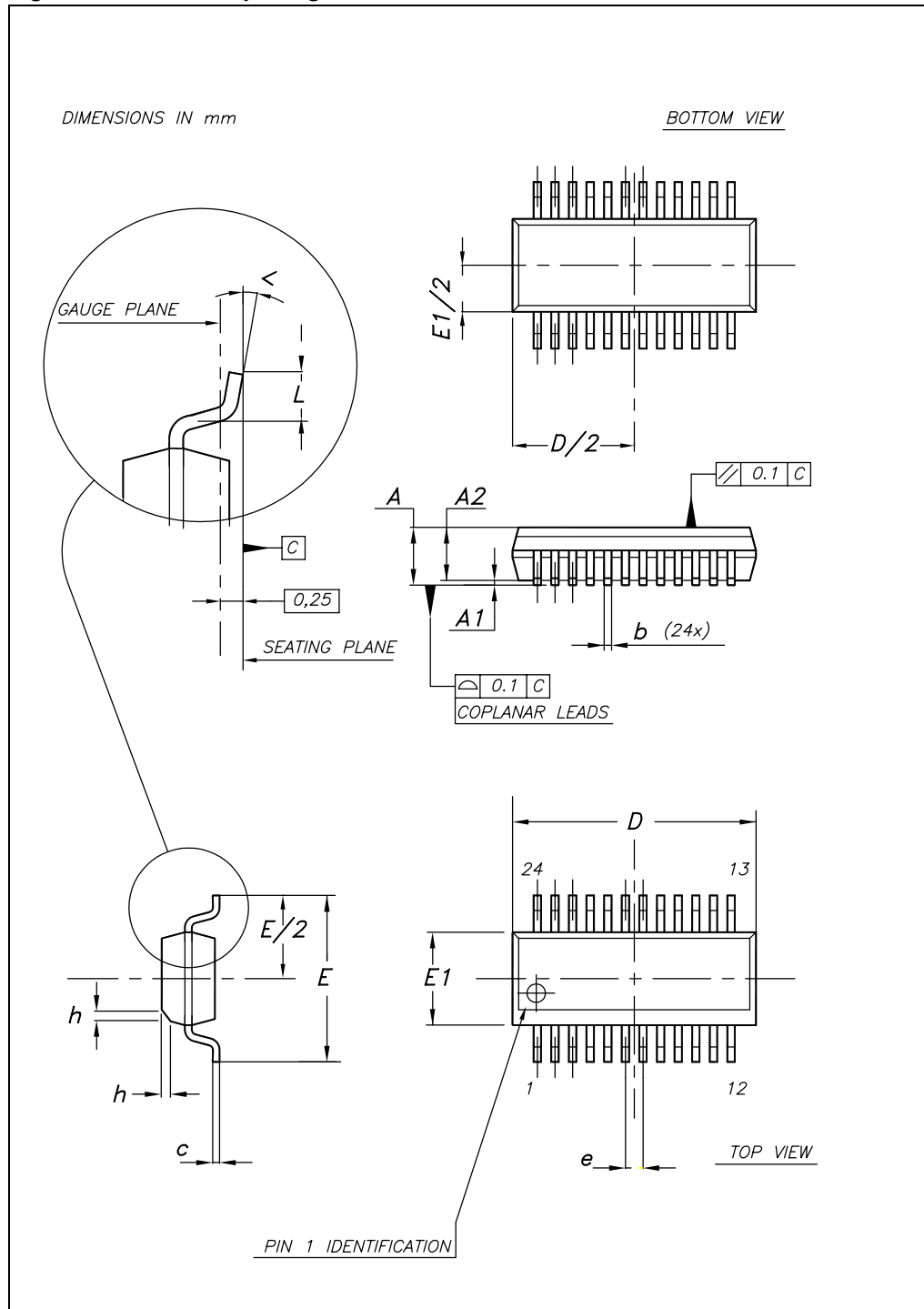

Table 17. QSOP-24 tape and reel

Dim.	mm.			inch		
	Min	Typ	Max	Min	Typ	Max
R1	12.8	13	13.5	5.039	5.118	5.315
R2		330			129.921	
R3		100			39.37	
eint		16.4			6.457	
e1	1.5	2	2.5	0.591	0.787	0.984

Table 18. QSOP-24 tape and reel dimensions

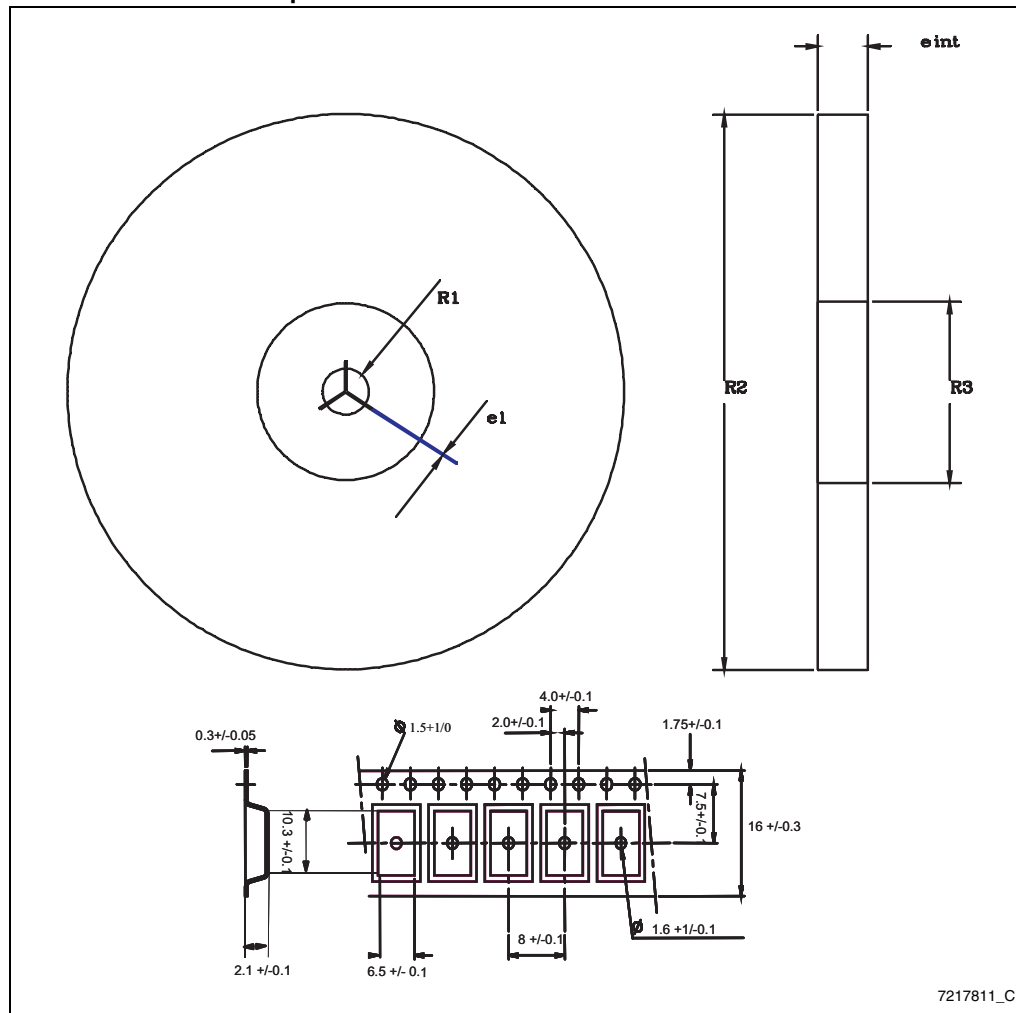

Table 19. TSSOP24 mechanical data

Dim.	mm.			inch		
	Min.	Typ.	Max.	Min.	Typ.	Max.
A			1.1			0.043
A1	0.05		0.15	0.002		0.006
A2		0.9			0.035	
b	0.19		0.30	0.0075		0.0118
c	0.09		0.20	0.0035		0.0079
D	7.7		7.9	0.303		0.311
E	4.3		4.5	0.169		0.177
e		0.65 BSC			0.0256 BSC	
H	6.25		6.5	0.246		0.256
K	0°		8°	0°		8°
L	0.50		0.70	0.020		0.028

Figure 25. TSSOP24 package dimensions

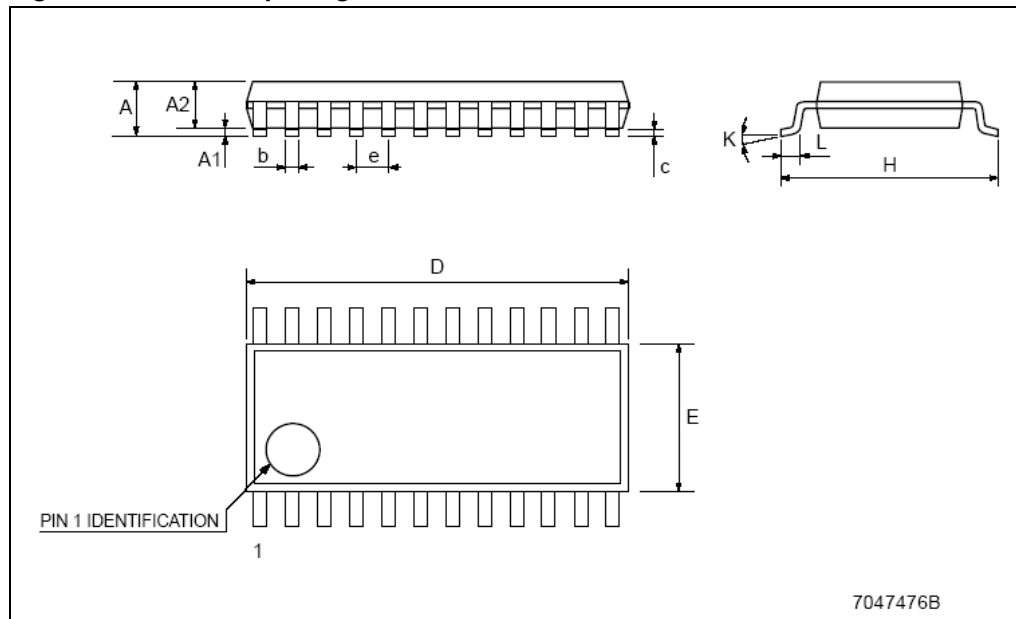

Table 20. TSSOP24 tape and reel

Dim.	mm.			inch		
	Min.	Typ.	Max.	Min.	Typ.	Max.
A		-	330		-	12.992
C	12.8	-	13.2	0.504	-	0.519
D	20.2	-		0.795	-	
N	60	-		2.362	-	
T		-	22.4		-	0.882
Ao	6.8	-	7	0.268	-	0.276
Bo	8.2	-	8.4	0.323	-	0.331
Ko	1.7	-	1.9	0.067	-	0.075
Po	3.9	-	4.1	0.153	-	0.161
P	11.9	-	12.1	0.468	-	0.476

Figure 26. Reel dimensions

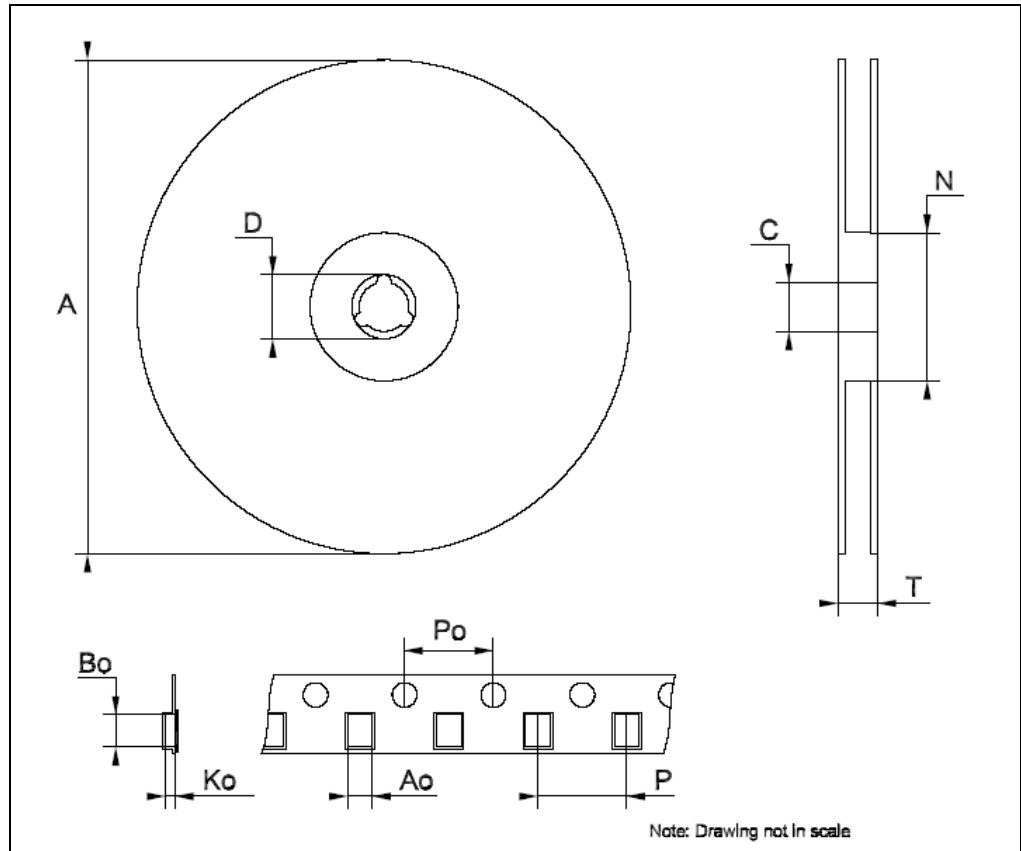

Table 21. SO-24 mechanical data

Dim.	mm.			inch		
	Min.	Typ.	Max.	Min.	Typ.	Max.
A			2.65			0.104
a1	0.1		0.2	0.004		0.008
a2			2.45			0.096
b	0.35		0.49	0.014		0.019
b1	0.23		0.32	0.009		0.012
C		0.5			0.020	
c1	45°(typ.)					
D	15.20		15.60	0.598		0.614
E	10.00		10.65	0.393		0.419
e		1.27			0.050	
e3		13.97			0.550	
F	7.40		7.60	0.291		0.300
L	0.50		1.27	0.020		0.050
S	°(max.) 8					

Figure 27. SO-24 package dimensions

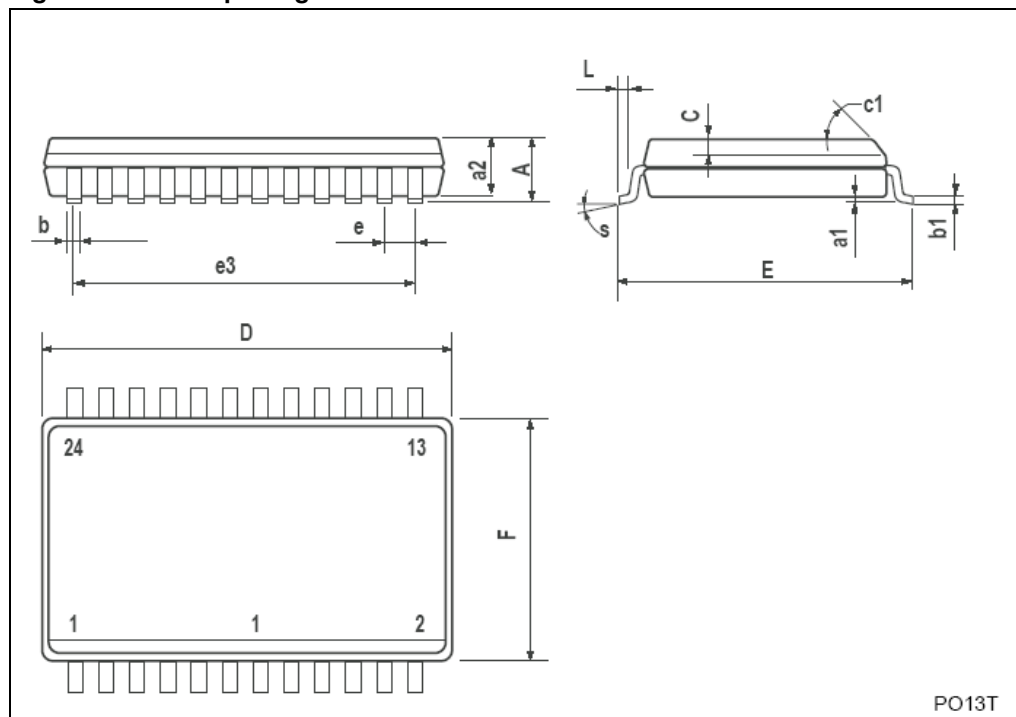

Table 22. SO-24 tape and reel

Dim.	mm.			inch		
	Min.	Typ.	Max.	Min.	Typ.	Max.
A		-	330		-	12.992
C	12.8	-	13.2	0.504	-	0.519
D	20.2	-		0.795	-	
N	60	-		2.362	-	
T		-	30.4		-	1.197
Ao	10.8	-	11.0	0.425	-	0.433
Bo	15.7	-	15.9	0.618	-	0.626
Ko	2.9	-	3.1	0.114	-	0.122
Po	3.9	-	4.1	0.153	-	0.161
P	11.9	-	12.1	0.468	-	0.476

Figure 28. Reel dimensions

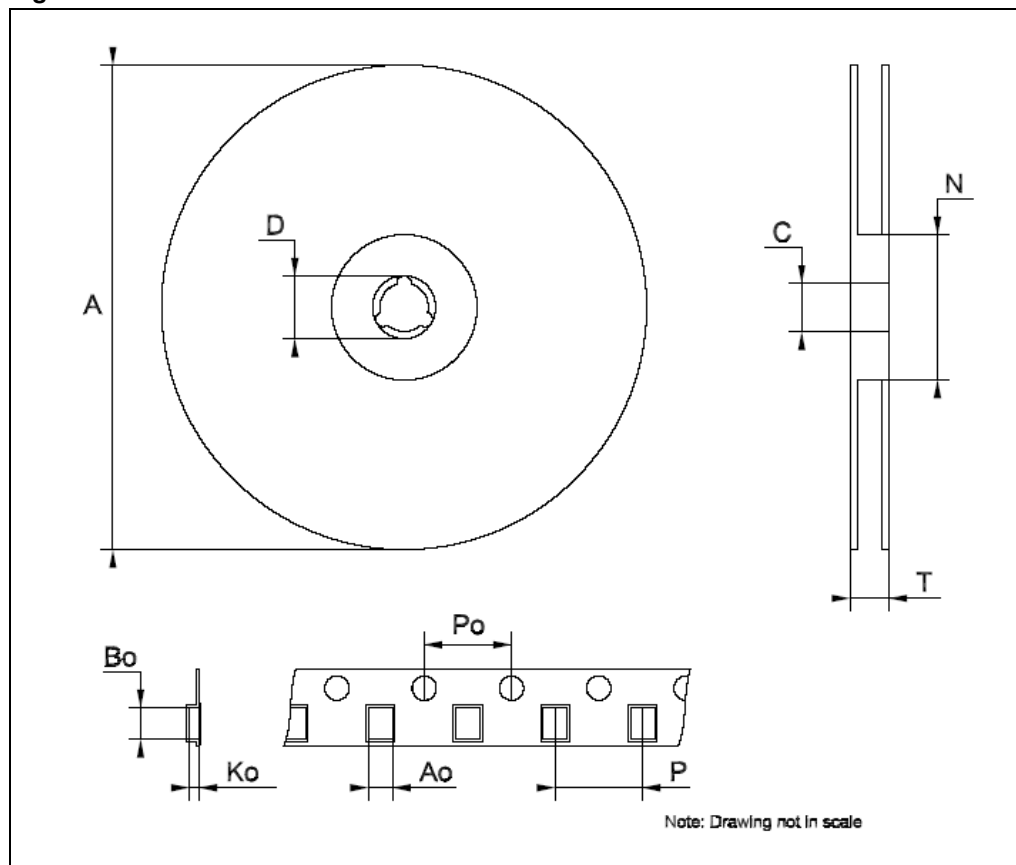
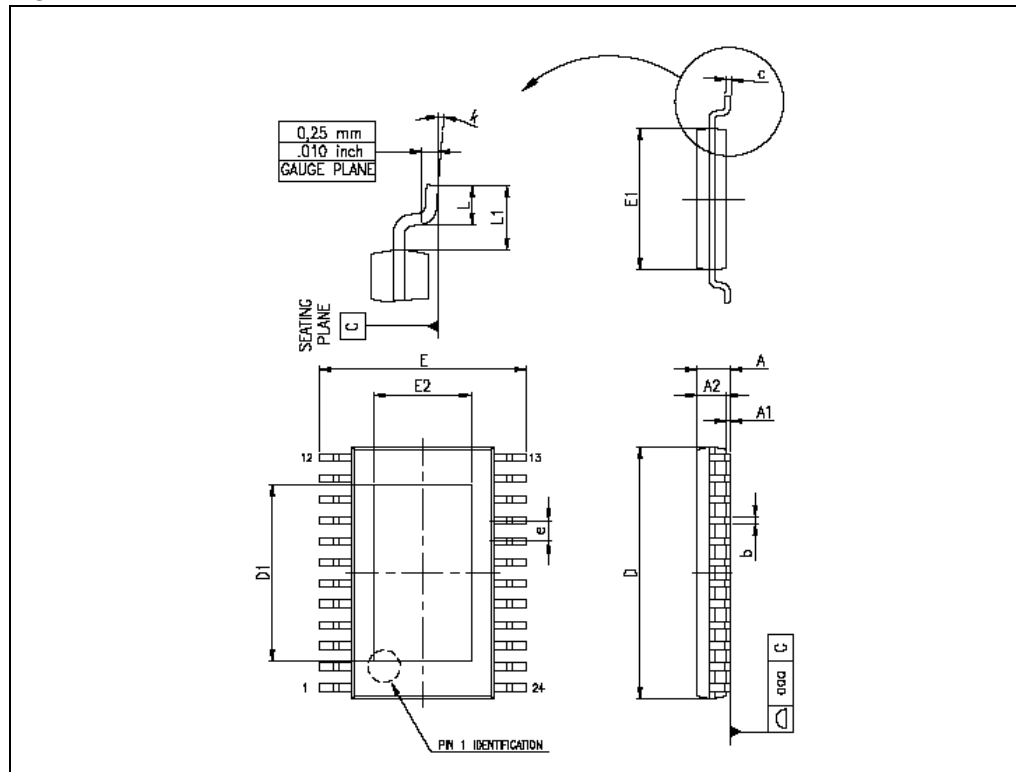

Table 23. TSSOP24 exposed pad

Dim.	mm			inch		
	Min.	Typ.	Max.	Min.	Typ.	Max.
A			1.2			0.047
A1			0.15		0.004	0.006
A2	0.8	1	1.05	0.031	0.039	0.041
b	0.19		0.30	0.007		0.012
c	0.09		0.20	0.004		0.0089
D	7.7	7.8	7.9	0.303	0.307	0.311
D1	4.7	5.0	5.3	0.185	0.197	0.209
E	6.2	6.4	6.6	0.244	0.252	0.260
E1	4.3	4.4	4.5	0.169	0.173	0.177
E2	2.9	3.2	3.5	0.114	0.126	0.138
e		0.65			0.0256	
K	0°		8°	0°		8°
L	0.45	0.60	0.75	0.018	0.024	0.030

Figure 29. TSSOP24 dimensions





## 9 Revision history

**Table 24. Document revision history**

Date	Revision	Changes
23-Oct-2009	1	First release
22-Jan-2010	2	Updated <a href="#">Table 5 on page 4</a>

**Please Read Carefully:**

Information in this document is provided solely in connection with ST products. STMicroelectronics NV and its subsidiaries ("ST") reserve the right to make changes, corrections, modifications or improvements, to this document, and the products and services described herein at any time, without notice.

All ST products are sold pursuant to ST's terms and conditions of sale.

Purchasers are solely responsible for the choice, selection and use of the ST products and services described herein, and ST assumes no liability whatsoever relating to the choice, selection or use of the ST products and services described herein.

No license, express or implied, by estoppel or otherwise, to any intellectual property rights is granted under this document. If any part of this document refers to any third party products or services it shall not be deemed a license grant by ST for the use of such third party products or services, or any intellectual property contained therein or considered as a warranty covering the use in any manner whatsoever of such third party products or services or any intellectual property contained therein.

**UNLESS OTHERWISE SET FORTH IN ST'S TERMS AND CONDITIONS OF SALE ST DISCLAIMS ANY EXPRESS OR IMPLIED WARRANTY WITH RESPECT TO THE USE AND/OR SALE OF ST PRODUCTS INCLUDING WITHOUT LIMITATION IMPLIED WARRANTIES OF MERCHANTABILITY, FITNESS FOR A PARTICULAR PURPOSE (AND THEIR EQUIVALENTS UNDER THE LAWS OF ANY JURISDICTION), OR INFRINGEMENT OF ANY PATENT, COPYRIGHT OR OTHER INTELLECTUAL PROPERTY RIGHT.**

**UNLESS EXPRESSLY APPROVED IN WRITING BY AN AUTHORIZED ST REPRESENTATIVE, ST PRODUCTS ARE NOT RECOMMENDED, AUTHORIZED OR WARRANTED FOR USE IN MILITARY, AIR CRAFT, SPACE, LIFE SAVING, OR LIFE SUSTAINING APPLICATIONS, NOR IN PRODUCTS OR SYSTEMS WHERE FAILURE OR MALFUNCTION MAY RESULT IN PERSONAL INJURY, DEATH, OR SEVERE PROPERTY OR ENVIRONMENTAL DAMAGE. ST PRODUCTS WHICH ARE NOT SPECIFIED AS "AUTOMOTIVE GRADE" MAY ONLY BE USED IN AUTOMOTIVE APPLICATIONS AT USER'S OWN RISK.**

Resale of ST products with provisions different from the statements and/or technical features set forth in this document shall immediately void any warranty granted by ST for the ST product or service described herein and shall not create or extend in any manner whatsoever, any liability of ST.

ST and the ST logo are trademarks or registered trademarks of ST in various countries.

Information in this document supersedes and replaces all information previously supplied.

The ST logo is a registered trademark of STMicroelectronics. All other names are the property of their respective owners.

© 2010 STMicroelectronics - All rights reserved

STMicroelectronics group of companies

Australia - Belgium - Brazil - Canada - China - Czech Republic - Finland - France - Germany - Hong Kong - India - Israel - Italy - Japan - Malaysia - Malta - Morocco - Philippines - Singapore - Spain - Sweden - Switzerland - United Kingdom - United States of America

[www.st.com](http://www.st.com)