

ZXSC380

Single or multi cell LED driver solution

Description

The ZXSC380 is a highly integrated single or multi cell LED driver for applications where step-up voltage conversion from a very low input voltage is required. These applications mainly operate from 1.5V or 1.2V cells. The IC generates constant current pulses that are ideal for driving single or multiple LEDs over a wide range of operating voltages. The ZXSC380 provides a simple to use, low cost, space saving and easy to layout solutions.

The ZXSC380 uses a PFM control technique to drive an internal switching transistor which has a low saturation resistance. This ensures high efficiency, even for input voltages as low as 1V.

Features

- 80% efficiency
- User adjustable output current
- Single cell operation
- Low saturation voltage switching transistor
- Simple application circuit
- Low external component count
- SOT23 package
- Available also in die form

Pin connections

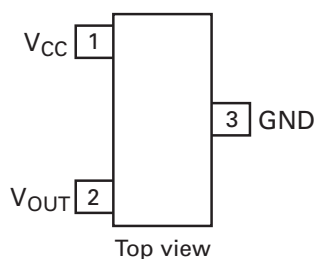

The IC can start up under full load and operates down to an input voltage of only 0.9V typical.

The ZXSC380 is offered in the space saving SOT23 package or in die form, offering an excellent cost vs performance solution for single cell LED driving applications.

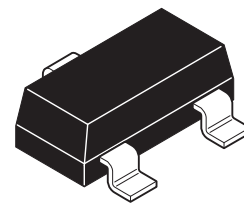

SOT23

Applications

- LED flashlights and torches
- LED backlights
- White LED driver

Typical application circuit

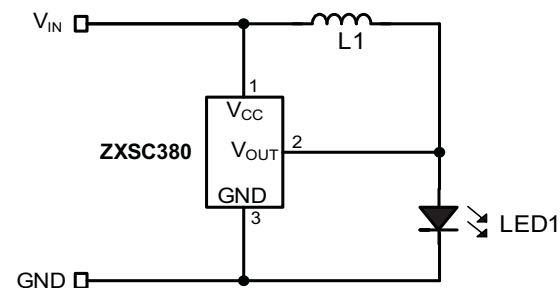

Absolute maximum ratings

Supply voltage (V_{CC})	-0.6V to 10V
Output voltage (V_{OUT})	-0.6V to 20V
Supply current	20mA
Output switch current	200mA
Power dissipation SOT23-3	450mW
Power dissipation die	1W
Operating temperature range	0°C to +85°C
Storage temperature range	-55°C to +150°C

Electrical characteristics

Measured at $T_{amb} = 25^{\circ}\text{C}$, $L = 100\mu\text{H}$ and $V_{CC} = 1.5\text{V}$ unless otherwise specified.

Parameter	Conditions	Limits			Units
		Min.	Typ.	Max.	
Supply voltage operating range		0.8		6	V
Minimum supply start-up voltage			0.9	1.0	V
Switch current	$V_{OUT} = 1.0\text{V}$	65	80	95	mA
Switch saturation voltage	$I_{V_{OUT}} = 50\text{mA}$		0.3	0.5	V
Mean LED current	$V_{LED} = 3.5\text{V}$		18		mA
Efficiency	$V_{LED} = 3.5\text{V}$		75		%
Operating frequency	$V_{LED} = 3.5\text{V}$		160		kHz
Discharge pulse width		1.4	2.2	3.0	μs

Pin descriptions

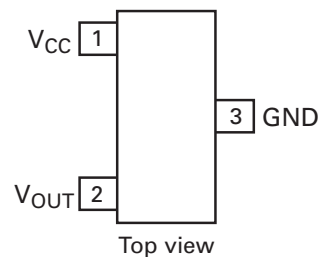

Pin descriptions

Pin No.	Name	Description
1	V_{CC}	Supply voltage, generally Alkaline, NiMH or NiCd single cell
2	V_{OUT}	Switch output external inductor/LED
3	GND	Ground

Ordering information

Device	Package	Part Mark
ZXSC380FH	SOT23	380

Typical characteristics

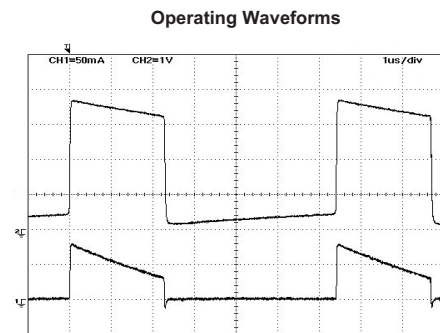
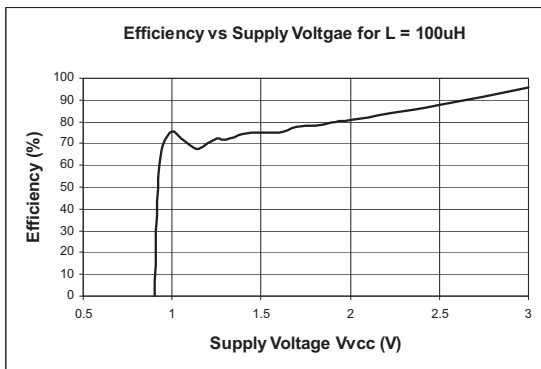
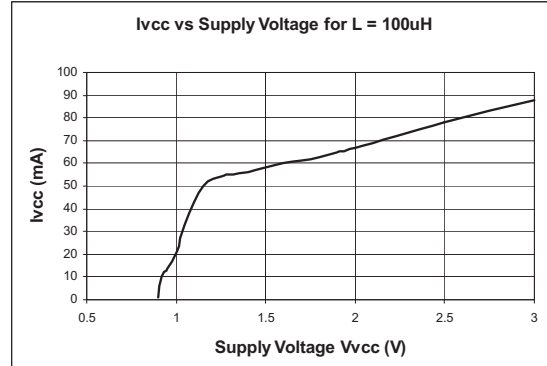
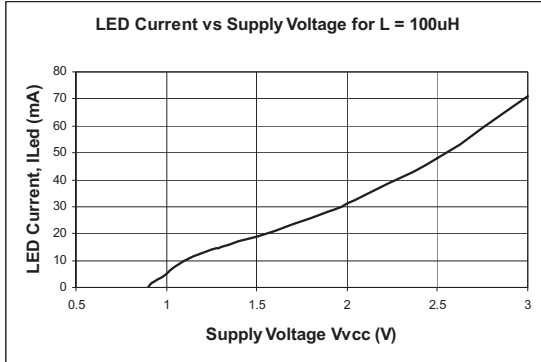

Channel 1 (lower): LED current I_{Led} . 50mA/div.
Channel 2 (upper): Voltage at Vout pin. 1V/div

Typical characteristics

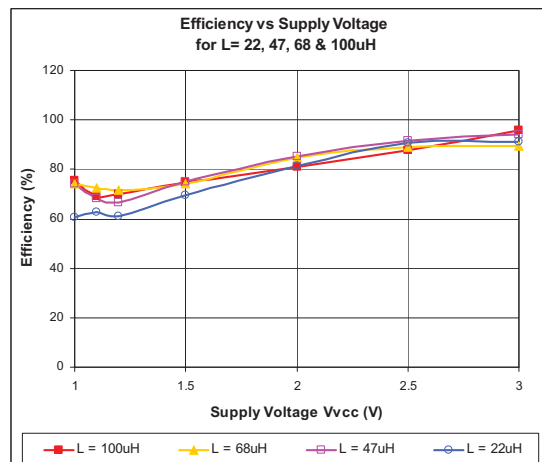
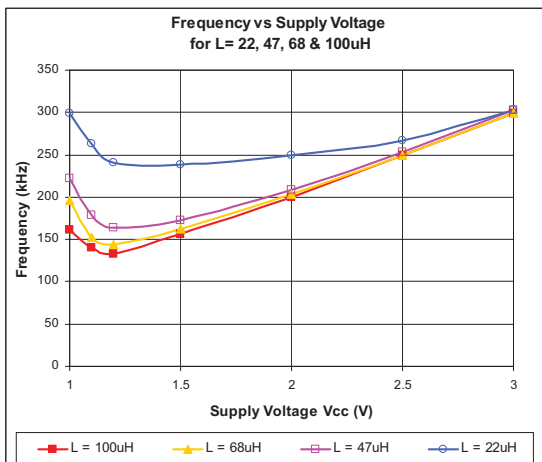
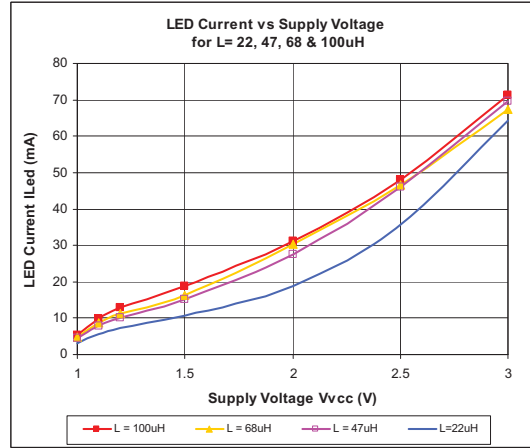
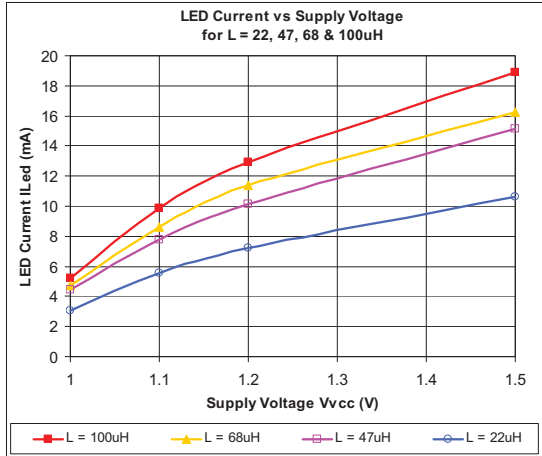

Device description

The ZXSC380 is non-synchronous PFM, DC-DC controller IC which, with a high performance internal transistor, for a high efficiency boost converter for use in single cell applications. A block diagram is shown in Figure 1.

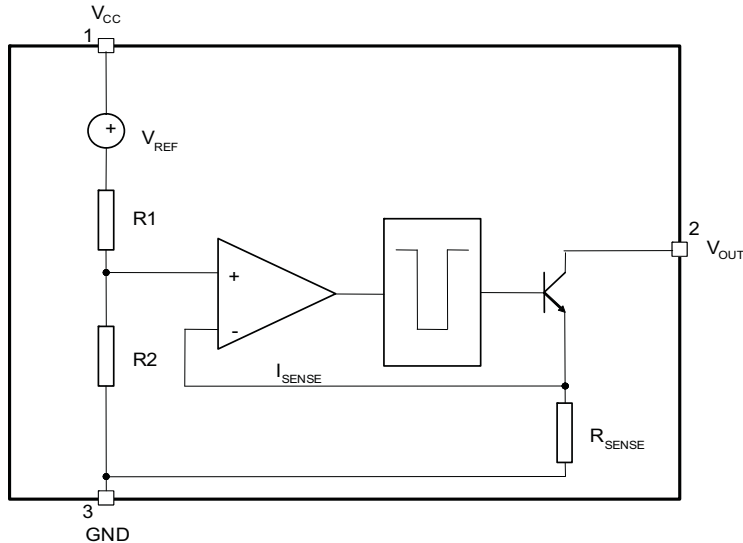

Figure 1 ZXSC380 Block diagram

The on chip comparator forces the driver circuit and therefore the internal switching transistor to switch off when the voltage at I_{SENSE} exceeds 20mV. This threshold is set by an internal reference circuit and divider. The voltage at I_{SENSE} is taken from a current sense resistor connected in series with the emitter of the switching transistor. This resistor is chosen to give 20mV at I_{SENSE} for an emitter current of 80mA.

A monostable following the output of the comparator forces the turn-off time of the output stage to be typically 2.2 μ s. This ensures that there is sufficient time to discharge a significant proportion of the energy stored in the inductor coil before the next On period.

With every On pulse the switching transistor is kept on until the voltage across the current-sense resistor exceeds the threshold of the I_{SENSE} input. The On-pulse length, and therefore the switching frequency, is determined by the programmed peak current, the input voltage and the input to output voltage differential. See applications section for details.

The Driver circuit supplies the internal switching transistor with a fixed drive current. To maximize efficiency the internal transistor is switched quickly, typically being switched off within 30ns.

Application notes

Typical application circuit

Figure 2 shows a typical boost circuit for 18mA LED current from a single cell 1.5V supply. The inductor value is 100 μ H. The operating frequency is typically 160kHz typical for 1.5V supply.

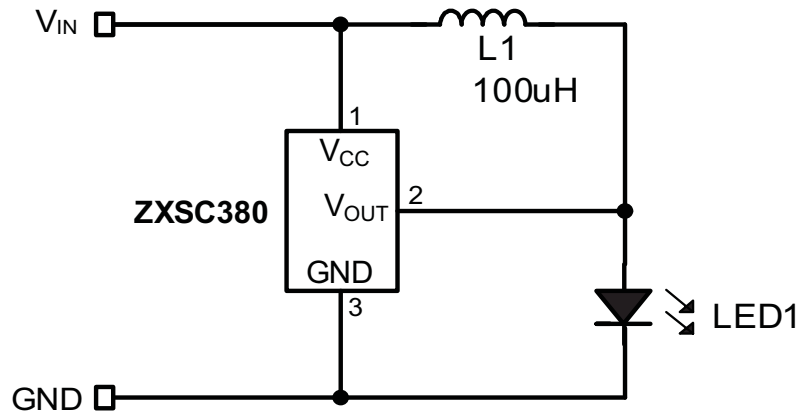

Figure 2 Typical application circuit

The LED current can be set by the choice of inductor values described below.

Inductor selection and current setting

Figure 3 shows the LED current vs the supply voltage while Figure 4 shows the switching frequency vs the supply voltage for various inductor values. Figure 3 and 4 can be used as guides to the inductor value selection. The inductor should have a low DC resistance for high efficiency. The switching frequency is dependent on the programmed peak current, the input voltage, the input to output voltage differential and the inductor value.

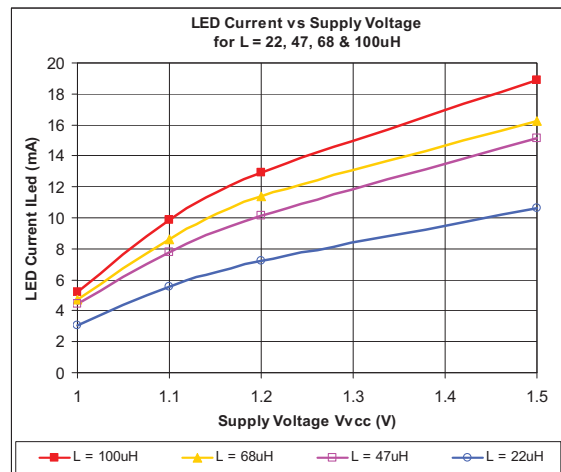

Figure 3 The LED current vs the supply voltage for various inductor values

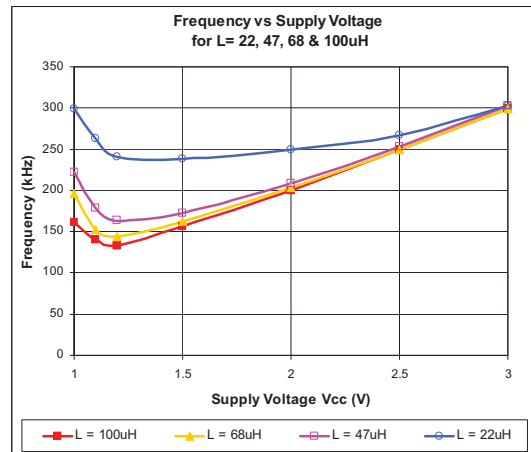

Figure 4 Switching frequency vs the supply voltage for various inductor values

Bootstrap operation

The ZXSC380 can be operated in bootstrap mode, as shown in Figure 5, to operate down to 0.7V typical after the initial successful start up. The operation down to 0.7V typical allows further cell energy to be extracted beyond typically quoted end of battery voltage of approx. 0.9. This prolongs the battery use time. (Note: Some batteries may have low voltage protections and may switch the supply off.) The schottky diodes, D1 and D2, should have a very low forward voltage, e.g. of such part is Zetex ZHCS400 (SOD323 package) or Zetex BAT54C (dual schottky diode with common Cathode). The start up voltage is 0.9V typical without bootstrap, however, due to the additional schottky, D1, being in the path of the supply to the Vcc pin, the start up voltage can be 1.1V typical for the bootstrap configuration.

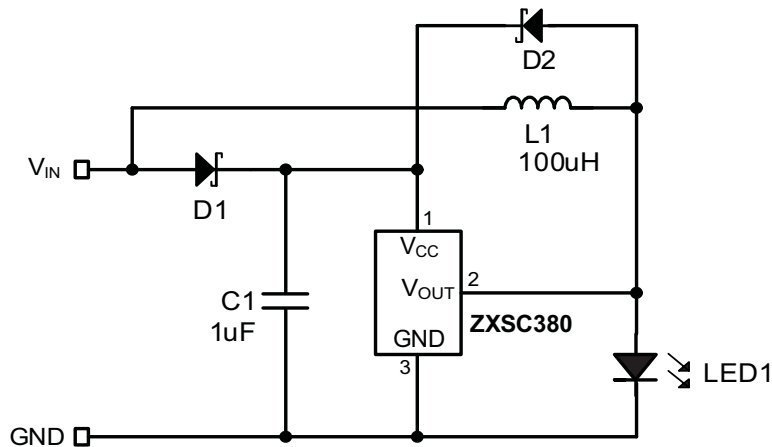
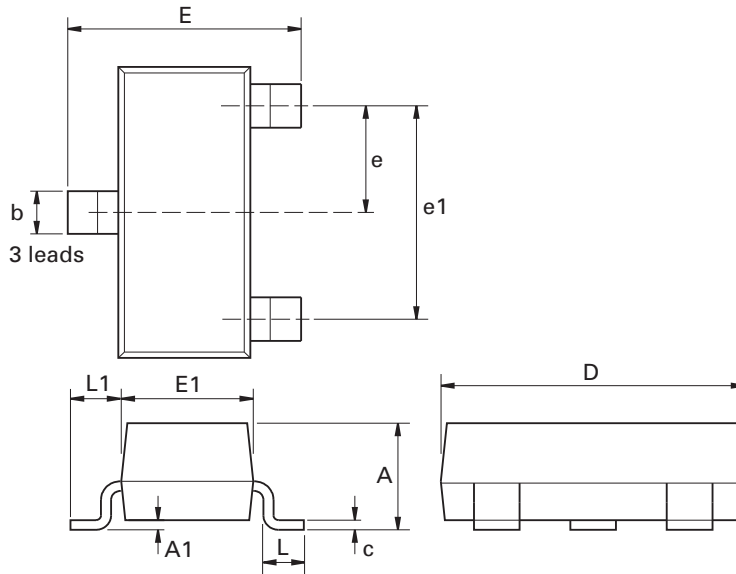

Figure 5 ZXSC380 in bootstrap mode

Intentionally left blank

Package outline - SOT23



Dim.	Millimeters		Inches		Dim.	Millimeters		Inches	
	Min.	Max.	Min.	Max.		Min.	Max.	Min.	Max.
A	-	1.12	-	0.044	e1	1.90 NOM		0.075 NOM	
A1	0.01	0.10	0.0004	0.004	E	2.10	2.64	0.083	0.104
b	0.30	0.50	0.012	0.020	E1	1.20	1.40	0.047	0.055
c	0.085	0.20	0.003	0.008	L	0.25	0.60	0.0098	0.0236
D	2.80	3.04	0.110	0.120	L1	0.45	0.62	0.018	0.024
e	0.95 NOM		0.037 NOM		-	-	-	-	-

Note: Controlling dimensions are in millimeters. Approximate dimensions are provided in inches

Definitions

Product change

Zetex Semiconductors reserves the right to alter, without notice, specifications, design, price or conditions of supply of any product or service. Customers are solely responsible for obtaining the latest relevant information before placing orders.

Applications disclaimer

The circuits in this design/application note are offered as design ideas. It is the responsibility of the user to ensure that the circuit is fit for the user's application and meets with the user's requirements. No representation or warranty is given and no liability whatsoever is assumed by Zetex with respect to the accuracy or use of such information, or infringement of patents or other intellectual property rights arising from such use or otherwise. Zetex does not assume any legal responsibility or will not be held legally liable (whether in contract, tort (including negligence), breach of statutory duty, restriction or otherwise) for any damages, loss of profit, business, contract, opportunity or consequential loss in the use of these circuit applications, under any circumstances.

Life support

Zetex products are specifically not authorized for use as critical components in life support devices or systems without the express written approval of the Chief Executive Officer of Zetex Semiconductors plc. As used herein:

A. Life support devices or systems are devices or systems which:

1. are intended to implant into the body

or

2. support or sustain life and whose failure to perform when properly used in accordance with instructions for use provided in the labelling can be reasonably expected to result in significant injury to the user.

B. A critical component is any component in a life support device or system whose failure to perform can be reasonably expected to cause the failure of the life support device or to affect its safety or effectiveness.

Reproduction

The product specifications contained in this publication are issued to provide outline information only which (unless agreed by the company in writing) may not be used, applied or reproduced for any purpose or form part of any order or contract or be regarded as a representation relating to the products or services concerned.

Terms and Conditions

All products are sold subjects to Zetex' terms and conditions of sale, and this disclaimer (save in the event of a conflict between the two when the terms of the contract shall prevail) according to region, supplied at the time of order acknowledgement.

For the latest information on technology, delivery terms and conditions and prices, please contact your nearest Zetex sales office.

Quality of product

Zetex is an ISO 9001 and TS16949 certified semiconductor manufacturer.

To ensure quality of service and products we strongly advise the purchase of parts directly from Zetex Semiconductors or one of our regionally authorized distributors. For a complete listing of authorized distributors please visit: www.zetex.com/salesnetwork

Zetex Semiconductors does not warrant or accept any liability whatsoever in respect of any parts purchased through unauthorized sales channels.

ESD (Electrostatic discharge)

Semiconductor devices are susceptible to damage by ESD. Suitable precautions should be taken when handling and transporting devices. The possible damage to devices depends on the circumstances of the handling and transporting, and the nature of the device. The extent of damage can vary from immediate functional or parametric malfunction to degradation of function or performance in use over time. Devices suspected of being affected should be replaced.

Green compliance

Zetex Semiconductors is committed to environmental excellence in all aspects of its operations which includes meeting or exceeding regulatory requirements with respect to the use of hazardous substances. Numerous successful programs have been implemented to reduce the use of hazardous substances and/or emissions.

All Zetex components are compliant with the RoHS directive, and through this it is supporting its customers in their compliance with WEEE and ELV directives.

Product status key:

"Preview"	Future device intended for production at some point. Samples may be available
"Active"	Product status recommended for new designs
"Last time buy (LTB)"	Device will be discontinued and last time buy period and delivery is in effect
"Not recommended for new designs"	Device is still in production to support existing designs and production
"Obsolete"	Production has been discontinued

Datasheet status key:

"Draft version"	This term denotes a very early datasheet version and contains highly provisional information, which may change in any manner without notice.
"Provisional version"	This term denotes a pre-release datasheet. It provides a clear indication of anticipated performance. However, changes to the test conditions and specifications may occur, at any time and without notice.
"Issue"	This term denotes an issued datasheet containing finalized specifications. However, changes to specifications may occur, at any time and without notice.

Zetex sales offices

Europe	Americas	Asia Pacific	Corporate Headquarters
Zetex GmbH Kustermann-park Balanstraße 59 D-81541 München Germany Telefon: (49) 89 45 49 49 0 Fax: (49) 89 45 49 49 49 europe.sales@zetex.com	Zetex Inc 700 Veterans Memorial Highway Hauppauge, NY 11788 USA Telephone: (1) 631 360 2222 Fax: (1) 631 360 8222 usa.sales@zetex.com	Zetex (Asia Ltd) 3701-04 Metroplaza Tower 1 Hing Fong Road, Kwai Fong Hong Kong Telephone: (852) 26100 611 Fax: (852) 24250 494 asia.sales@zetex.com	Zetex Semiconductors plc Zetex Technology Park, Chadderton Oldham, OL9 9LL United Kingdom Telephone: (44) 161 622 4444 Fax: (44) 161 622 4446 hq@zetex.com

© 2007 Published by Zetex Semiconductors plc