



PCF85162

Universal LCD driver for low multiplex rates

Rev. 02 — 7 May 2010

Product data sheet

1. General description

The PCF85162 is a peripheral device which interfaces to almost any Liquid Crystal Display (LCD)¹ with low multiplex rates. It generates the drive signals for any static or multiplexed LCD containing up to four backplanes and up to 32 segments. It can be easily cascaded for larger LCD applications. The PCF85162 is compatible with most microprocessors or microcontrollers and communicates via a two-line bidirectional I²C-bus. Communication overheads are minimized by a display RAM with auto-incremented addressing, by hardware subaddressing, and by display memory switching (static and duplex drive modes).

2. Features and benefits

- Single chip LCD controller and driver
- Selectable backplane drive configuration: static, 2, 3, or 4 backplane multiplexing
- Selectable display bias configuration: static, 1/2, or 1/3
- Internal LCD bias generation with voltage-follower buffers
- 32 segment drives:
 - ◆ Up to sixteen 7-segment numeric characters
 - ◆ Up to eight 14-segment alphanumeric characters
 - ◆ Any graphics of up to 128 elements
- 32 × 4-bit RAM for display data storage
- Auto-incremented display data loading across device subaddress boundaries
- Display memory bank switching in static and duplex drive modes
- Versatile blinking modes
- Independent supplies possible for LCD and logic voltages
- Wide power supply range: from 1.8 V to 5.5 V
- Wide logic LCD supply range:
 - ◆ From 2.5 V for low-threshold LCDs
 - ◆ Up to 6.5 V for guest-host LCDs and high-threshold twisted nematic LCDs
- Low power consumption
- 400 kHz I²C-bus interface
- No external components required
- Manufactured in silicon gate CMOS process

1. The definition of the abbreviations and acronyms used in this data sheet can be found in [Section 16](#).



3. Ordering information

Table 1. Ordering information

Type number	Package		Version
	Name	Description	
PCF85162T/1	TSSOP48	plastic thin shrink small outline package; 48 leads; body width 6.1 mm	SOT362-1

4. Marking

Table 2. Marking codes

Type number	Marking code
PCF85162T/1	PCF85162T

5. Block diagram

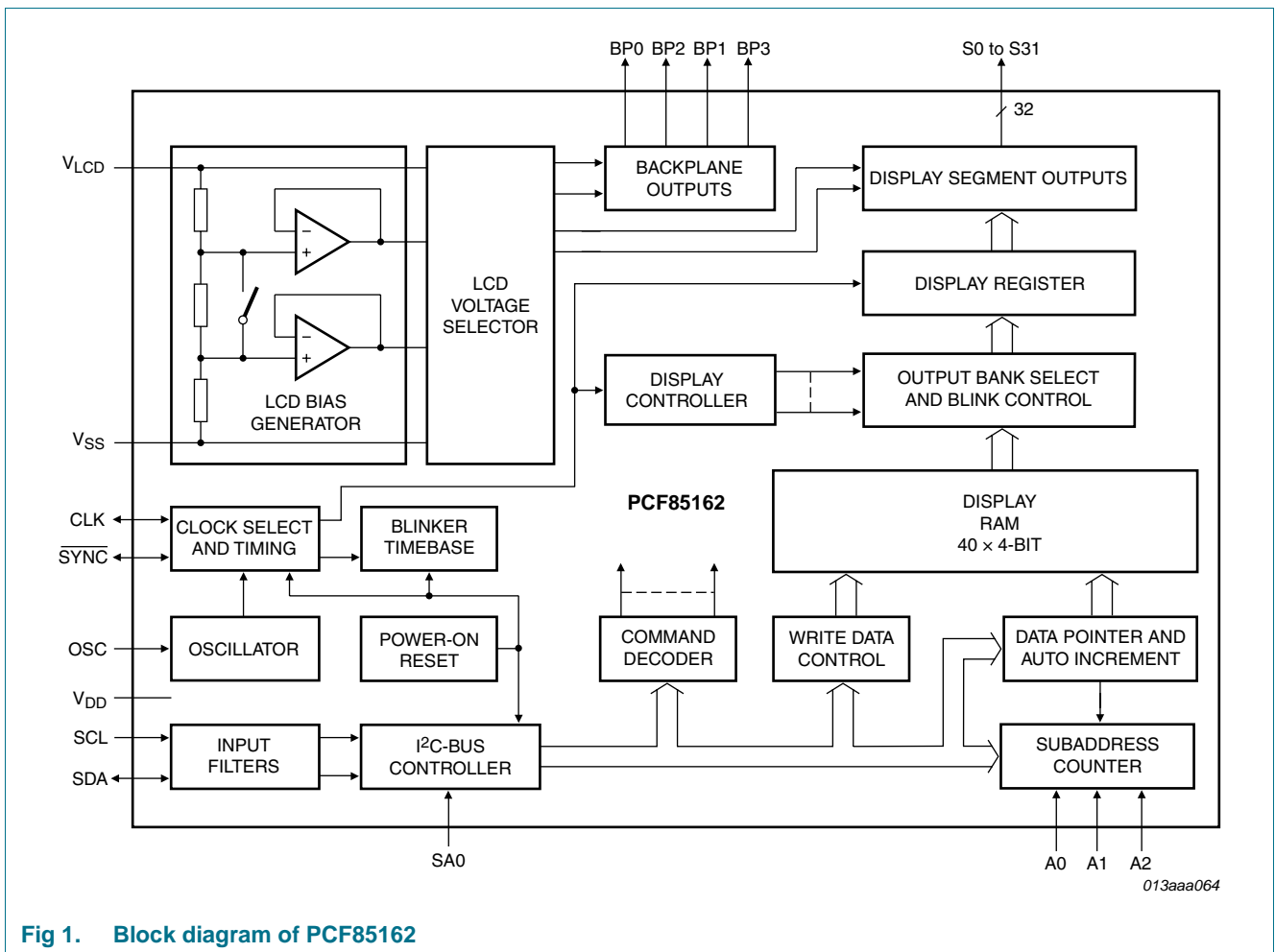
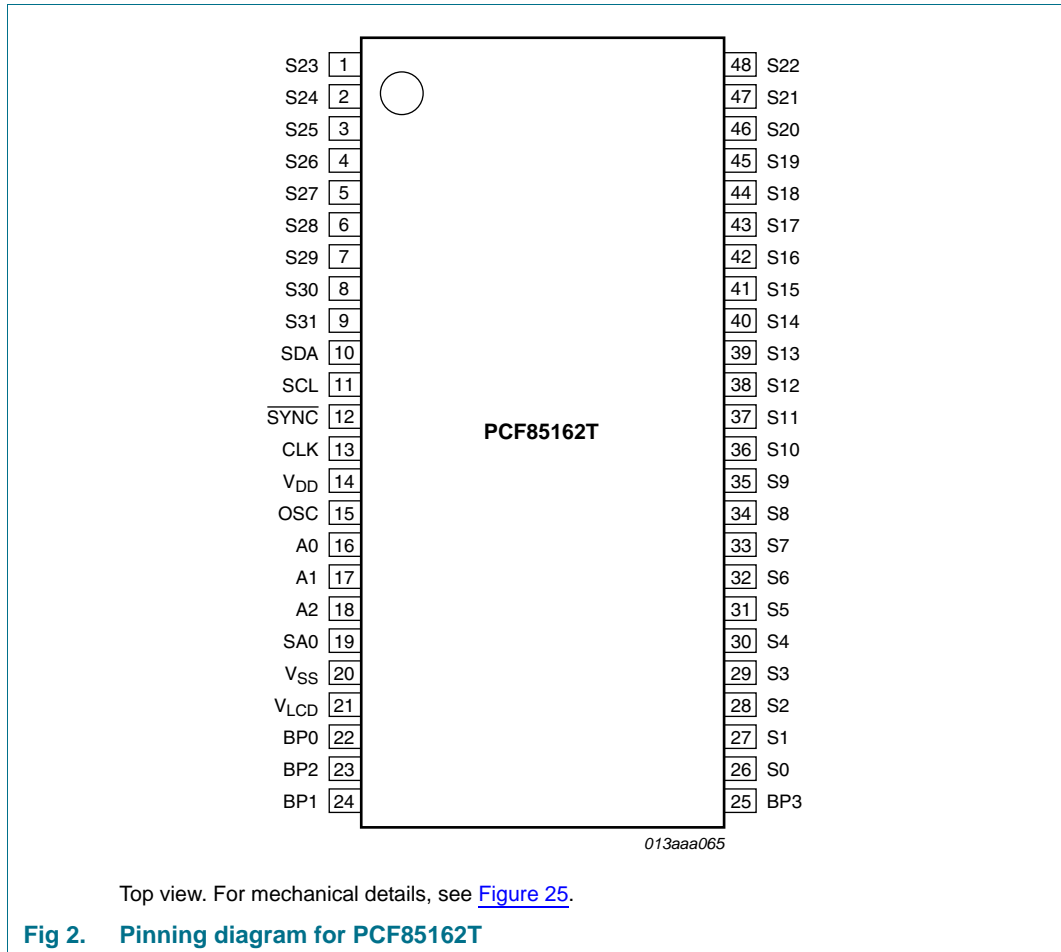

Fig 1. Block diagram of PCF85162

6. Pinning information

6.1 Pinning



6.2 Pin description

Table 3. Pin description

Symbol	Pin	Type	Description
SDA	10	input/output	I ² C-bus serial data line
SCL	11	input	I ² C-bus serial clock
$\overline{\text{SYNC}}$	12	input/output	cascade synchronization
CLK	13	input/output	clock line
V _{DD}	14	supply	supply voltage
OSC	15	input	internal oscillator enable
A0 to A2	16 to 18	input	subaddress inputs
SA0	19	input	I ² C-bus address input
V _{SS}	20	supply	ground supply voltage
V _{LCD}	21	supply	LCD supply voltage
BP0 to BP3	22 to 25	output	LCD backplane outputs
S0 to S22, S23 to S31	26 to 48, 1 to 9	output	LCD segment outputs

7. Functional description

The PCF85162 is a versatile peripheral device designed to interface between any microprocessor or microcontroller to a wide variety of LCD segment or dot matrix displays (see [Figure 3](#)). It can directly drive any static or multiplexed LCD containing up to four backplanes and up to 32 segments.

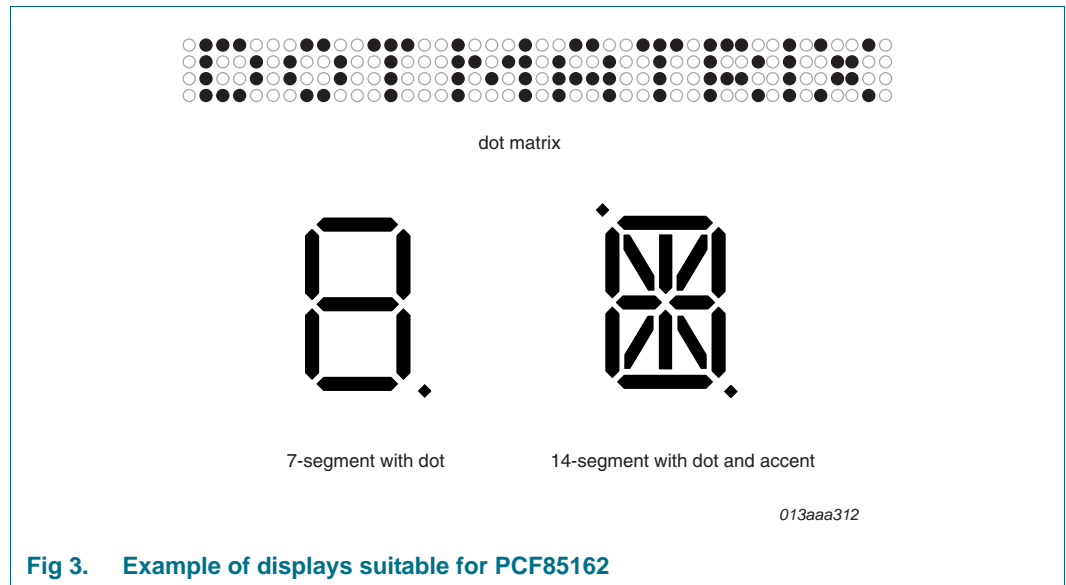
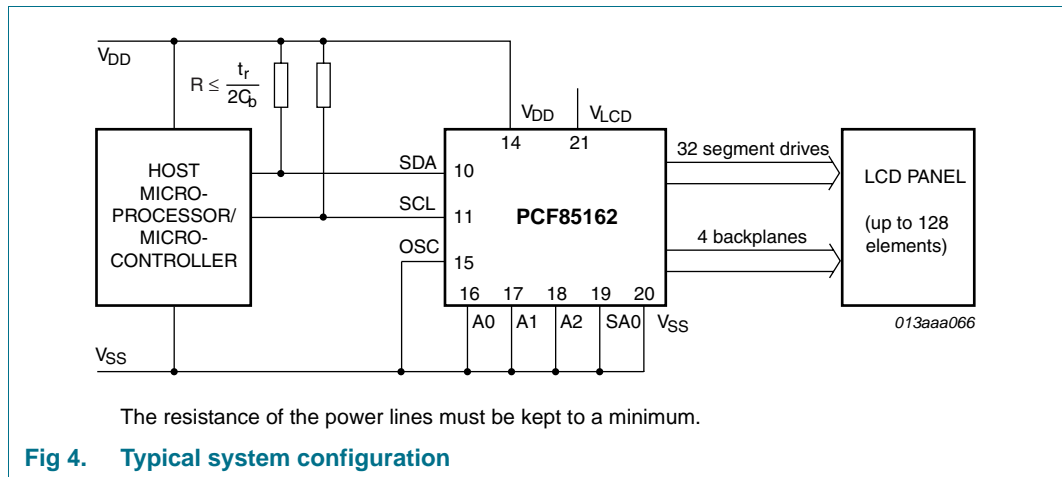

Fig 3. Example of displays suitable for PCF85162

The possible display configurations of the PCF85162 depend on the number of active backplane outputs required. A selection of display configurations is shown in [Table 4](#). All of these configurations can be implemented in the typical system shown in [Figure 4](#).

Table 4. Selection of possible display configurations

Number of Backplanes	Icons	Digits/Characters		Dot matrix/Elements
		7-segment	14-segment	
4	128	16	8	128 dots (4 × 32)
3	96	12	6	96 dots (3 × 32)
2	64	8	4	64 dots (2 × 32)
1	32	4	2	32 dots (1 × 32)



The host microprocessor or microcontroller maintains the 2-line I²C-bus communication channel with the PCF85162. The internal oscillator is enabled by connecting pin OSC to pin V_{SS}. The appropriate biasing voltages for the multiplexed LCD waveforms are generated internally. The only other connections required to complete the system are to the power supplies (V_{DD}, V_{SS}, and V_{LCD}) and the LCD panel chosen for the application.

7.1 Power-on reset

At power-on the PCF85162 resets to the following starting conditions:

- All backplane and segment outputs are set to V_{LCD}
- The selected drive mode is: 1:4 multiplex with 1/3 bias
- Blinking is switched off
- Input and output bank selectors are reset
- The I²C-bus interface is initialized
- The data pointer and the subaddress counter are cleared (set to logic 0)
- Display is disabled

Remark: Do not transfer data on the I²C-bus for at least 1 ms after a power-on to allow the reset action to complete.

7.2 LCD bias generator

Fractional LCD biasing voltages are obtained from an internal voltage divider consisting of three impedances connected in series between V_{LCD} and V_{SS}. The center impedance is bypassed by switch if the 1/2 bias voltage level for the 1:2 multiplex drive mode configuration is selected. The LCD voltage can be temperature compensated externally, using the supply to pin V_{LCD}.

7.3 LCD voltage selector

The LCD voltage selector coordinates the multiplexing of the LCD in accordance with the selected LCD drive configuration. The operation of the voltage selector is controlled by the mode-set command from the command decoder. The biasing configurations that apply to the preferred modes of operation, together with the biasing characteristics as functions of V_{LCD} and the resulting discrimination ratios (D) are given in [Table 5](#).

Table 5. Biasing characteristics

LCD drive mode	Number of:		LCD bias configuration	$\frac{V_{off(RMS)}}{V_{LCD}}$	$\frac{V_{on(RMS)}}{V_{LCD}}$	$D = \frac{V_{on(RMS)}}{V_{off(RMS)}}$
	Backplanes	Levels				
static	1	2	static	0	1	∞
1:2 multiplex	2	3	$\frac{1}{2}$	0.354	0.791	2.236
1:2 multiplex	2	4	$\frac{1}{3}$	0.333	0.745	2.236
1:3 multiplex	3	4	$\frac{1}{3}$	0.333	0.638	1.915
1:4 multiplex	4	4	$\frac{1}{3}$	0.333	0.577	1.732

A practical value for V_{LCD} is determined by equating $V_{off(RMS)}$ with a defined LCD threshold voltage (V_{th}), typically when the LCD exhibits approximately 10 % contrast. In the static drive mode a suitable choice is $V_{LCD} > 3V_{th}$.

Multiplex drive modes of 1:3 and 1:4 with $\frac{1}{2}$ bias are possible but the discrimination and hence the contrast ratios are smaller.

Bias is calculated by $\frac{1}{1+a}$, where the values for a are

a = 1 for $\frac{1}{2}$ bias

a = 2 for $\frac{1}{3}$ bias

The RMS on-state voltage ($V_{on(RMS)}$) for the LCD is calculated with [Equation 1](#):

$$V_{on(RMS)} = V_{LCD} \sqrt{\frac{a^2 + 2a + n}{n \times (1 + a)^2}} \tag{1}$$

where the values for n are

n = 1 for static drive mode

n = 2 for 1:2 multiplex drive mode

n = 3 for 1:3 multiplex drive mode

n = 4 for 1:4 multiplex drive mode

The RMS off-state voltage ($V_{off(RMS)}$) for the LCD is calculated with [Equation 2](#):

$$V_{off(RMS)} = V_{LCD} \sqrt{\frac{a^2 - 2a + n}{n \times (1 + a)^2}} \tag{2}$$

Discrimination is the ratio of $V_{on(RMS)}$ to $V_{off(RMS)}$ and is determined from [Equation 3](#):

$$D = \frac{V_{on(RMS)}}{V_{off(RMS)}} = \sqrt{\frac{(a + 1)^2 + (n - 1)}{(a - 1)^2 + (n - 1)}} \tag{3}$$

Using [Equation 3](#), the discrimination for an LCD drive mode of 1:3 multiplex with $\frac{1}{2}$ bias is $\sqrt{3} = 1.732$ and the discrimination for an LCD drive mode of 1:4 multiplex with $\frac{1}{2}$ bias is $\frac{\sqrt{21}}{3} = 1.528$.

The advantage of these LCD drive modes is a reduction of the LCD full scale voltage V_{LCD} as follows:

- 1:3 multiplex ($\frac{1}{2}$ bias): $V_{LCD} = \sqrt{6} \times V_{off(RMS)} = 2.449V_{off(RMS)}$
- 1:4 multiplex ($\frac{1}{2}$ bias): $V_{LCD} = \left[\frac{4 \times \sqrt{3}}{3} \right] = 2.309V_{off(RMS)}$

These compare with $V_{LCD} = 3V_{off(RMS)}$ when $\frac{1}{3}$ bias is used.

It should be noted that V_{LCD} is sometimes referred as the LCD operating voltage.

7.4 LCD drive mode waveforms

7.4.1 Static drive mode

The static LCD drive mode is used when a single backplane is provided in the LCD. The backplane (BPn) and segment (Sn) drive waveforms for this mode are shown in [Figure 5](#).

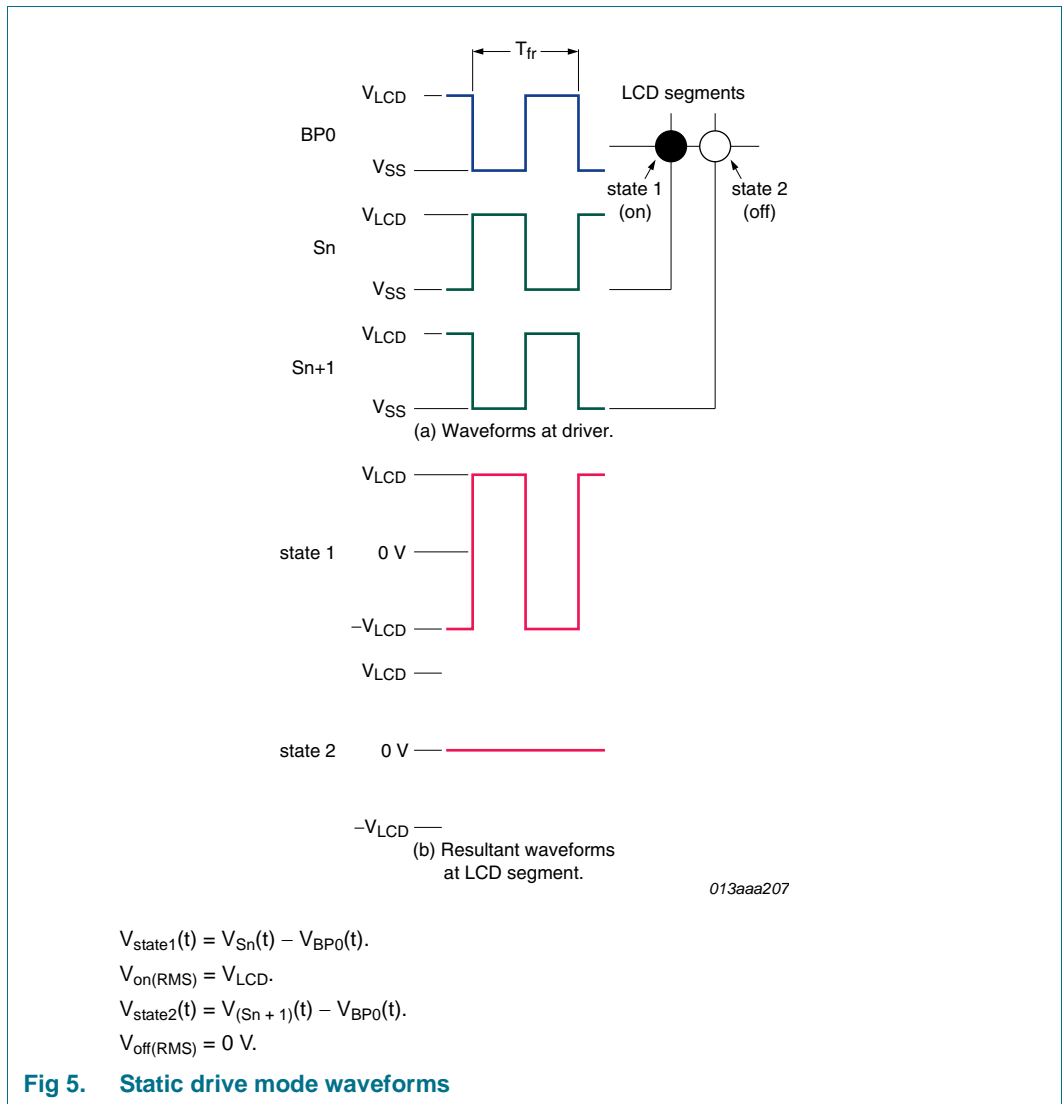

Fig 5. Static drive mode waveforms

7.4.2 1:2 Multiplex drive mode

When two backplanes are provided in the LCD, the 1:2 multiplex mode applies. The PCF85162 allows the use of 1/2 bias or 1/3 bias in this mode as shown in Figure 6 and Figure 7.

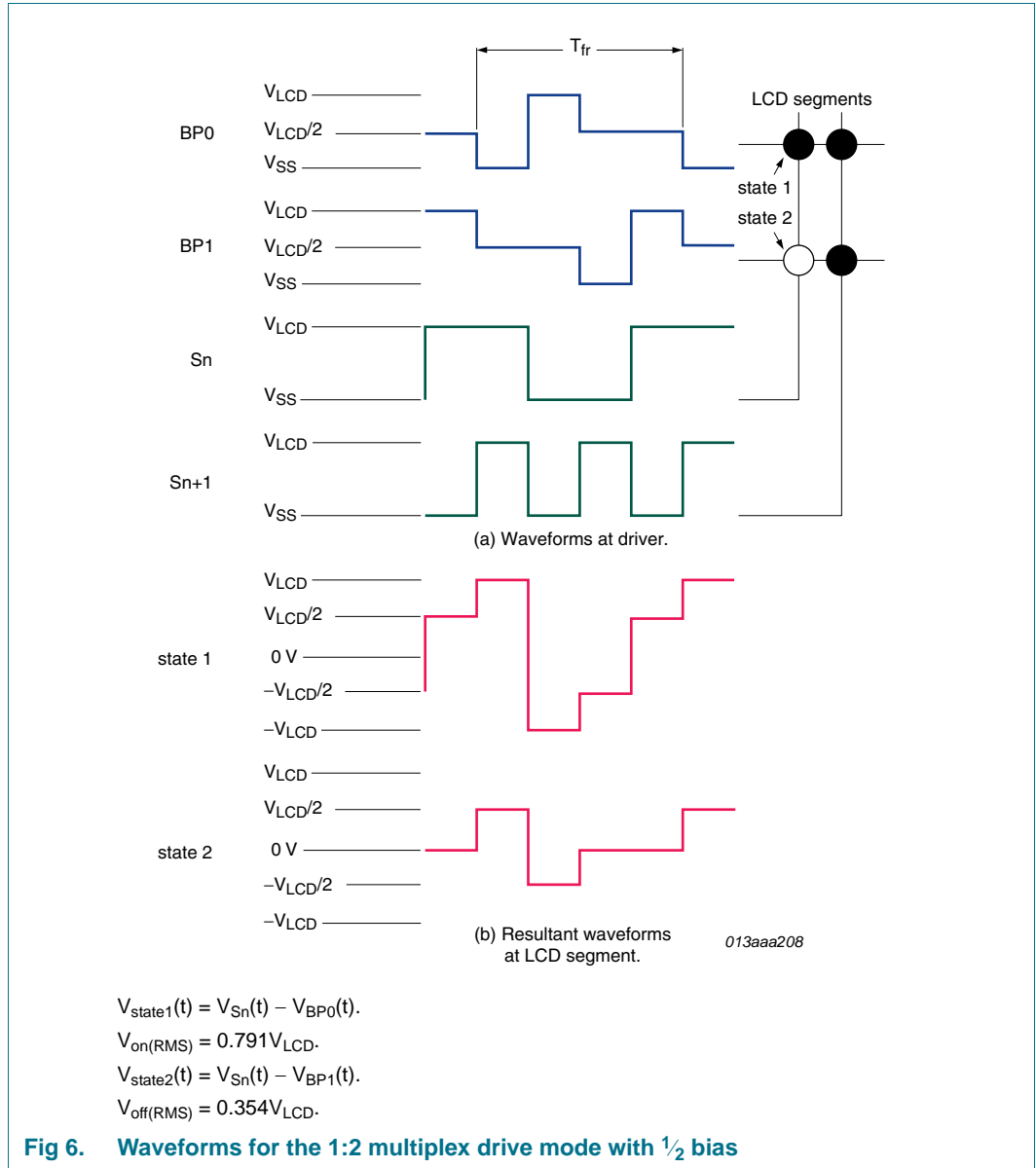

Fig 6. Waveforms for the 1:2 multiplex drive mode with 1/2 bias

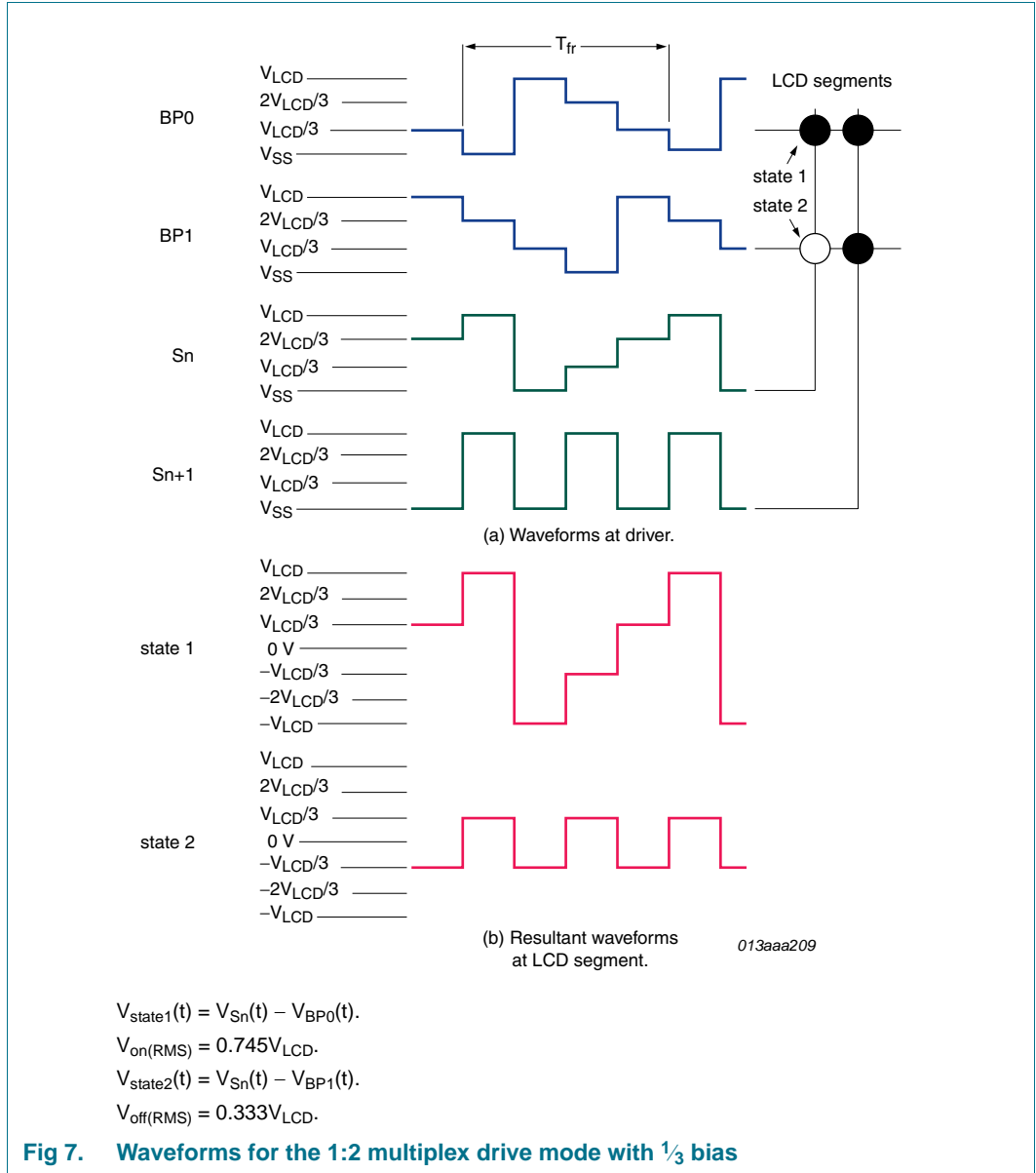

Fig 7. Waveforms for the 1:2 multiplex drive mode with 1/3 bias

7.4.3 1:3 Multiplex drive mode

When three backplanes are provided in the LCD, the 1:3 multiplex drive mode applies, as shown in Figure 8.

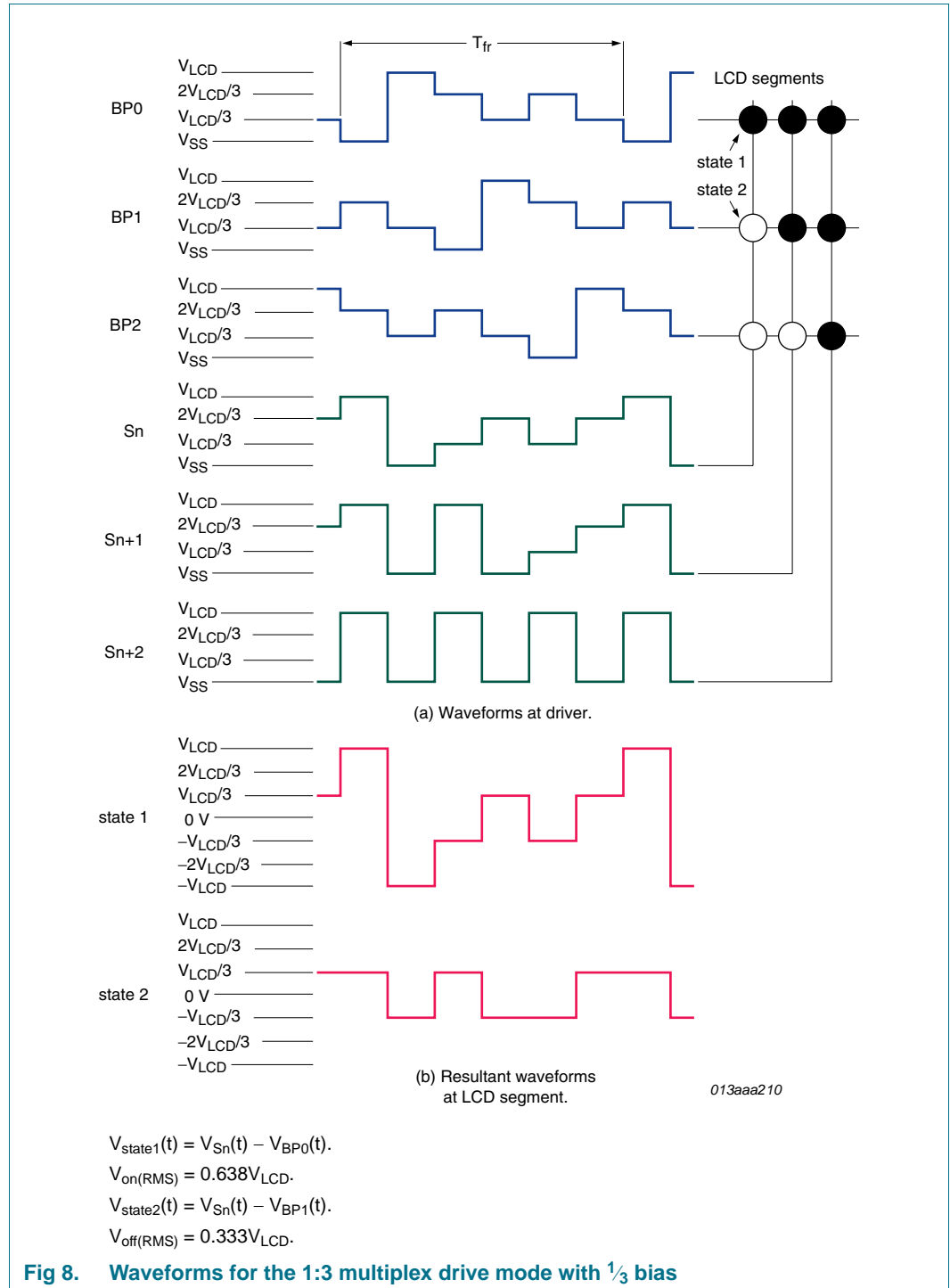

Fig 8. Waveforms for the 1:3 multiplex drive mode with 1/3 bias

7.4.4 1:4 Multiplex drive mode

When four backplanes are provided in the LCD, the 1:4 multiplex drive mode applies as shown in Figure 9.

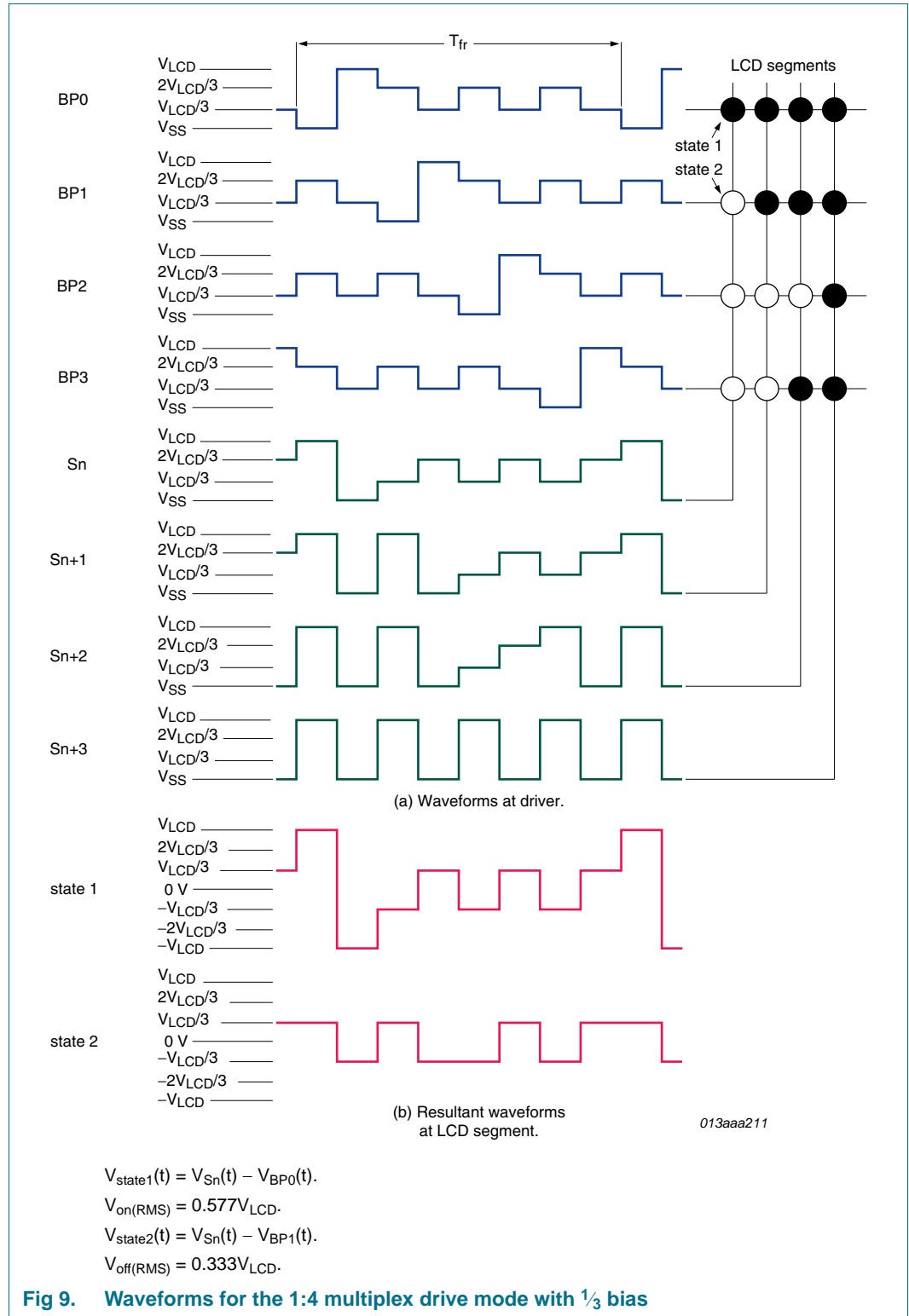

Fig 9. Waveforms for the 1:4 multiplex drive mode with 1/3 bias

7.5 Oscillator

7.5.1 Internal clock

The internal logic of the PCF85162 and its LCD drive signals are timed either by its internal oscillator or by an external clock. The internal oscillator is enabled by connecting pin OSC to pin V_{SS}. If the internal oscillator is used, the output from pin CLK can be used as the clock signal for several PCF85162 in the system that are connected in cascade.

7.5.2 External clock

Pin CLK is enabled as an external clock input by connecting pin OSC to V_{DD}. The LCD frame signal frequency is determined by the clock frequency (f_{clk}).

Remark: A clock signal must always be supplied to the device; removing the clock may freeze the LCD in a DC state, which is not suitable for the liquid crystal.

7.6 Timing

The PCF85162 timing controls the internal data flow of the device. This includes the transfer of display data from the display RAM to the display segment outputs. In cascaded applications, the correct timing relationship between each PCF85162 in the system is maintained by the synchronization signal at pin \overline{SYNC} . The timing also generates the LCD frame signal whose frequency is derived from the clock frequency. The frame signal frequency is a fixed division of the clock frequency from either the internal or an external

$$\text{clock: } f_{fr} = \frac{f_{clk}}{24}$$

7.7 Display register

The display register holds the display data while the corresponding multiplex signals are generated.

7.8 Segment outputs

The LCD drive section includes 32 segment outputs S0 to S31 which should be connected directly to the LCD. The segment output signals are generated in accordance with the multiplexed backplane signals and with data residing in the display register. When less than 32 segment outputs are required, the unused segment outputs should be left open-circuit.

7.9 Backplane outputs

The LCD drive section includes four backplane outputs BP0 to BP3 which must be connected directly to the LCD. The backplane output signals are generated in accordance with the selected LCD drive mode. If less than four backplane outputs are required, the unused outputs can be left open-circuit.

- In the 1:3 multiplex drive mode, BP3 carries the same signal as BP1, therefore these two adjacent outputs can be tied together to give enhanced drive capabilities.
- In the 1:2 multiplex drive mode, BP0 and BP2, BP1 and BP3 all carry the same signals and may also be paired to increase the drive capabilities.

- In the static drive mode the same signal is carried by all four backplane outputs and they can be connected in parallel for very high drive requirements.

7.10 Display RAM

The display RAM is a static 32 × 4-bit RAM which stores LCD data. There is a one-to-one correspondence between

- the bits in the RAM bitmap and the LCD elements
- the RAM columns and the segment outputs
- the RAM rows and the backplane outputs.

A logic 1 in the RAM bitmap indicates the on-state of the corresponding LCD element; similarly, a logic 0 indicates the off-state.

The display RAM bit map [Figure 10](#) shows the rows 0 to 3 which correspond with the backplane outputs BP0 to BP3, and the columns 0 to 31 which correspond with the segment outputs S0 to S31. In multiplexed LCD applications the segment data of the first, second, third, and fourth row of the display RAM are time-multiplexed with BP0, BP1, BP2, and BP3 respectively.

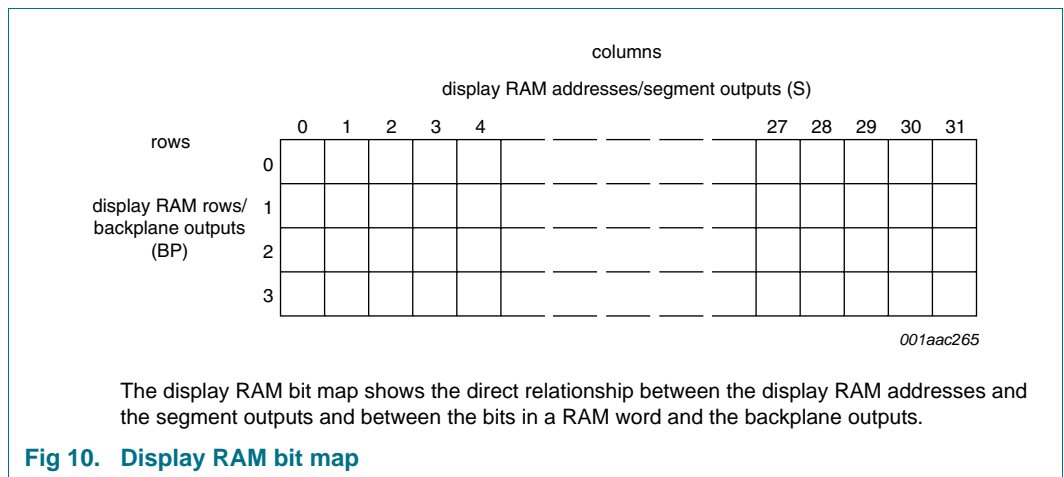

When display data is transmitted to the PCF85162, the display bytes received are stored in the display RAM in accordance with the selected LCD drive mode. The data is stored as it arrives and does not wait for an acknowledge cycle as with the commands. Depending on the current multiplex drive mode, data is stored singularly, in pairs, triples or quadruples. To illustrate the filling order, an example of a 7-segment numeric display showing all drive modes is given in [Figure 11](#); the RAM filling organization depicted applies equally to other LCD types.

drive mode	LCD segments	LCD backplanes	display RAM filling order	transmitted display byte																																																					
static			<p>columns display RAM address/segment outputs (s) byte1</p> <table border="1"> <tr> <td></td> <td>n</td> <td>n + 1</td> <td>n + 2</td> <td>n + 3</td> <td>n + 4</td> <td>n + 5</td> <td>n + 6</td> <td>n + 7</td> </tr> <tr> <td>rows display RAM</td> <td>c</td> <td>b</td> <td>a</td> <td>f</td> <td>g</td> <td>e</td> <td>d</td> <td>DP</td> </tr> <tr> <td>rows/backplane</td> <td>x</td> <td>x</td> <td>x</td> <td>x</td> <td>x</td> <td>x</td> <td>x</td> <td>x</td> </tr> <tr> <td>outputs (BP)</td> <td>x</td> <td>x</td> <td>x</td> <td>x</td> <td>x</td> <td>x</td> <td>x</td> <td>x</td> </tr> <tr> <td></td> <td>x</td> <td>x</td> <td>x</td> <td>x</td> <td>x</td> <td>x</td> <td>x</td> <td>x</td> </tr> </table>		n	n + 1	n + 2	n + 3	n + 4	n + 5	n + 6	n + 7	rows display RAM	c	b	a	f	g	e	d	DP	rows/backplane	x	x	x	x	x	x	x	x	outputs (BP)	x	x	x	x	x	x	x	x		x	x	x	x	x	x	x	x	<p>MSB</p> <p>LSB</p> <table border="1"> <tr> <td>c</td> <td>b</td> <td>a</td> <td>f</td> <td>g</td> <td>e</td> <td>d</td> <td>DP</td> </tr> </table>	c	b	a	f	g	e	d	DP
	n	n + 1	n + 2	n + 3	n + 4	n + 5	n + 6	n + 7																																																	
rows display RAM	c	b	a	f	g	e	d	DP																																																	
rows/backplane	x	x	x	x	x	x	x	x																																																	
outputs (BP)	x	x	x	x	x	x	x	x																																																	
	x	x	x	x	x	x	x	x																																																	
c	b	a	f	g	e	d	DP																																																		
1:2 multiplex			<p>columns display RAM address/segment outputs (s) byte1</p> <table border="1"> <tr> <td></td> <td>n</td> <td>n + 1</td> <td>n + 2</td> <td>n + 3</td> </tr> <tr> <td>rows display RAM</td> <td>a</td> <td>f</td> <td>e</td> <td>d</td> </tr> <tr> <td>rows/backplane</td> <td>b</td> <td>g</td> <td>c</td> <td>DP</td> </tr> <tr> <td>outputs (BP)</td> <td>x</td> <td>x</td> <td>x</td> <td>x</td> </tr> <tr> <td></td> <td>x</td> <td>x</td> <td>x</td> <td>x</td> </tr> </table>		n	n + 1	n + 2	n + 3	rows display RAM	a	f	e	d	rows/backplane	b	g	c	DP	outputs (BP)	x	x	x	x		x	x	x	x	<p>MSB</p> <p>LSB</p> <table border="1"> <tr> <td>a</td> <td>b</td> <td>f</td> <td>g</td> <td>e</td> <td>c</td> <td>d</td> <td>DP</td> </tr> </table>	a	b	f	g	e	c	d	DP																				
	n	n + 1	n + 2	n + 3																																																					
rows display RAM	a	f	e	d																																																					
rows/backplane	b	g	c	DP																																																					
outputs (BP)	x	x	x	x																																																					
	x	x	x	x																																																					
a	b	f	g	e	c	d	DP																																																		
1:3 multiplex			<p>columns display RAM address/segment outputs (s) byte1</p> <table border="1"> <tr> <td></td> <td>n</td> <td>n + 1</td> <td>n + 2</td> </tr> <tr> <td>rows display RAM</td> <td>b</td> <td>a</td> <td>f</td> </tr> <tr> <td>rows/backplane</td> <td>DP</td> <td>d</td> <td>e</td> </tr> <tr> <td>outputs (BP)</td> <td>c</td> <td>g</td> <td>x</td> </tr> <tr> <td></td> <td>x</td> <td>x</td> <td>x</td> </tr> </table>		n	n + 1	n + 2	rows display RAM	b	a	f	rows/backplane	DP	d	e	outputs (BP)	c	g	x		x	x	x	<p>MSB</p> <p>LSB</p> <table border="1"> <tr> <td>b</td> <td>DP</td> <td>c</td> <td>a</td> <td>d</td> <td>g</td> <td>f</td> <td>e</td> </tr> </table>	b	DP	c	a	d	g	f	e																									
	n	n + 1	n + 2																																																						
rows display RAM	b	a	f																																																						
rows/backplane	DP	d	e																																																						
outputs (BP)	c	g	x																																																						
	x	x	x																																																						
b	DP	c	a	d	g	f	e																																																		
1:4 multiplex			<p>columns display RAM address/segment outputs (s) byte1</p> <table border="1"> <tr> <td></td> <td>n</td> <td>n + 1</td> </tr> <tr> <td>rows display RAM</td> <td>a</td> <td>f</td> </tr> <tr> <td>rows/backplane</td> <td>c</td> <td>e</td> </tr> <tr> <td>outputs (BP)</td> <td>b</td> <td>g</td> </tr> <tr> <td></td> <td>DP</td> <td>d</td> </tr> </table>		n	n + 1	rows display RAM	a	f	rows/backplane	c	e	outputs (BP)	b	g		DP	d	<p>MSB</p> <p>LSB</p> <table border="1"> <tr> <td>a</td> <td>c</td> <td>b</td> <td>DP</td> <td>f</td> <td>e</td> <td>g</td> <td>d</td> </tr> </table>	a	c	b	DP	f	e	g	d																														
	n	n + 1																																																							
rows display RAM	a	f																																																							
rows/backplane	c	e																																																							
outputs (BP)	b	g																																																							
	DP	d																																																							
a	c	b	DP	f	e	g	d																																																		

001aa|646

x = data bit unchanged.

Fig 11. Relationship between LCD layout, drive mode, display RAM filling order, and display data transmitted over the I²C-bus

The following applies to [Figure 11](#):

- In static drive mode the eight transmitted data bits are placed in row 0 as one byte.
- In 1:2 multiplex drive mode the eight transmitted data bits are placed in pairs into row 0 and 1 as two successive 4-bit RAM words.
- In 1:3 multiplex drive mode the eight bits are placed in triples into row 0, 1, and 2 as three successive 3-bit RAM words, with bit 3 of the third address left unchanged. It is not recommended to use this bit in a display because of the difficult addressing. This last bit may, if necessary, be controlled by an additional transfer to this address but care should be taken to avoid overwriting adjacent data because always full bytes are transmitted.
- In 1:4 multiplex drive mode, the eight transmitted data bits are placed in quadruples into row 0, 1, 2, and 3 as two successive 4-bit RAM words.

7.11 Data pointer

The addressing mechanism for the display RAM is realized using the data pointer. This allows the loading of an individual display data byte, or a series of display data bytes, into any location of the display RAM. The sequence commences with the initialization of the data pointer by the load-data-pointer command (see [Table 11](#)). Following this command, an arriving data byte is stored at the display RAM address indicated by the data pointer. The filling order is shown in [Figure 11](#).

After each byte is stored, the content of the data pointer is automatically incremented by a value dependent on the selected LCD drive mode:

- In static drive mode by eight
- In 1:2 multiplex drive mode by four
- In 1:3 multiplex drive mode by three
- In 1:4 multiplex drive mode by two

If an I²C-bus data access is terminated early then the state of the data pointer is unknown. The data pointer should be re-written prior to further RAM accesses.

7.12 Subaddress counter

The storage of display data is determined by the contents of the subaddress counter. Storage is allowed only when the content of the subaddress counter matches with the hardware subaddress applied to A0, A1 and A2. The subaddress counter value is defined by the device-select command (see [Table 12](#)). If the content of the subaddress counter and the hardware subaddress do not match then data storage is inhibited but the data pointer is incremented as if data storage had taken place. The subaddress counter is also incremented when the data pointer overflows.

In cascaded applications each PCF85162 in the cascade must be addressed separately. Initially, the first PCF85162 is selected by sending the device-select command matching the first device's hardware subaddress. Then the data pointer is set to the preferred display RAM address by sending the load-data-pointer command.

Once the display RAM of the first PCF85162 has been written, the second PCF85162 is selected by sending the device-select command again. This time however the command matches the second device's hardware subaddress. Next the load-data-pointer command is sent to select the preferred display RAM address of the second PCF85162.

This last step is very important because during writing data to the first PCF85162, the data pointer of the second PCF85162 is incremented. In addition, the hardware subaddress should not be changed whilst the device is being accessed on the I²C-bus interface.

7.13 Output bank selector

The output bank selector (see [Table 13](#)) selects one of the four rows per display RAM address for transfer to the display register. The actual row selected depends on the particular LCD drive mode in operation and on the instant in the multiplex sequence.

- In 1:4 multiplex mode, all RAM addresses of row 0 are selected, these are followed by the contents of row 1, 2, and then 3
- In 1:3 multiplex mode, rows 0, 1, and 2 are selected sequentially
- In 1:2 multiplex mode, rows 0 and 1 are selected
- In static mode, row 0 is selected

The PCF85162 includes a RAM bank switching feature in the static and 1:2 multiplex drive modes. In the static drive mode, the bank-select command may request the contents of row 2 to be selected for display instead of the contents of row 0. In the 1:2 multiplex mode, the contents of rows 2 and 3 may be selected instead of rows 0 and 1. This gives the provision for preparing display information in an alternative bank and to be able to switch to it once it is assembled.

7.14 Input bank selector

The input bank selector loads display data into the display RAM in accordance with the selected LCD drive configuration. Display data can be loaded in row 2 in static drive mode or in rows 2 and 3 in 1:2 multiplex drive mode by using the bank-select command (see [Table 13](#)). The input bank selector functions independently to the output bank selector.

7.15 Blinker

The display blinking capabilities of the PCF85162 are very versatile. The whole display can blink at a frequencies selected by the blink-select command (see [Table 14](#)). The blink frequencies are fractions of the clock frequency. The ratio between the clock and blink frequencies depends on the blink mode selected (see [Table 6](#)).

An additional feature is for an arbitrary selection of LCD elements to blink. This applies to the static and 1:2 multiplex drive modes and can be implemented without any communication overheads. By means of the output bank selector, the displayed RAM banks are exchanged with alternate RAM banks at the blink frequency. This mode can also be specified by the blink-select command.

In the 1:3 and 1:4 multiplex modes, where no alternative RAM bank is available, groups of LCD elements can blink by selectively changing the display RAM data at fixed time intervals.

Table 6. Blink frequencies^[1]

Blink mode	Blink frequency equation
off	-
1	$f_{blink} = \frac{f_{clk}}{768}$
2	$f_{blink} = \frac{f_{clk}}{1536}$
3	$f_{blink} = \frac{f_{clk}}{3072}$

[1] The blink frequency is proportional to the clock frequency (f_{clk}). For the range of the clock frequency see [Table 17](#).

The entire display can blink at a frequency other than the nominal blink frequency. This can be effectively performed by resetting and setting the display enable bit E at the required rate using the mode-set command (see [Table 10](#)).

7.16 Characteristics of the I²C-bus

The I²C-bus is for bidirectional, two-line communication between different ICs or modules. The two lines are a Serial Data line (SDA) and a Serial Clock Line (SCL). Both lines must be connected to a positive supply via a pull-up resistor when connected to the output stages of a device. Data transfer may be initiated only when the bus is not busy.

7.16.1 Bit transfer

One data bit is transferred during each clock pulse. The data on the SDA line must remain stable during the HIGH period of the clock pulse as changes in the data line at this time will be interpreted as a control signal (see [Figure 12](#)).

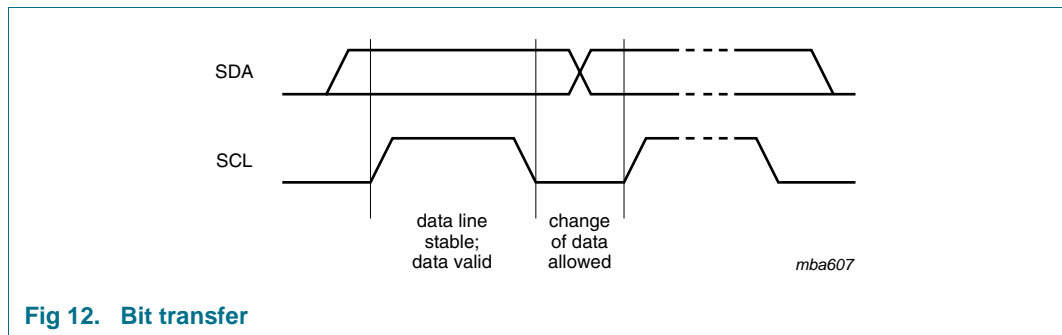

Fig 12. Bit transfer

7.16.2 START and STOP conditions

Both data and clock lines remain HIGH when the bus is not busy.

A HIGH-to-LOW transition of the data line while the clock is HIGH is defined as the START condition (S).

A LOW-to-HIGH transition of the data line while the clock is HIGH is defined as the STOP condition (P) (see [Figure 13](#)).

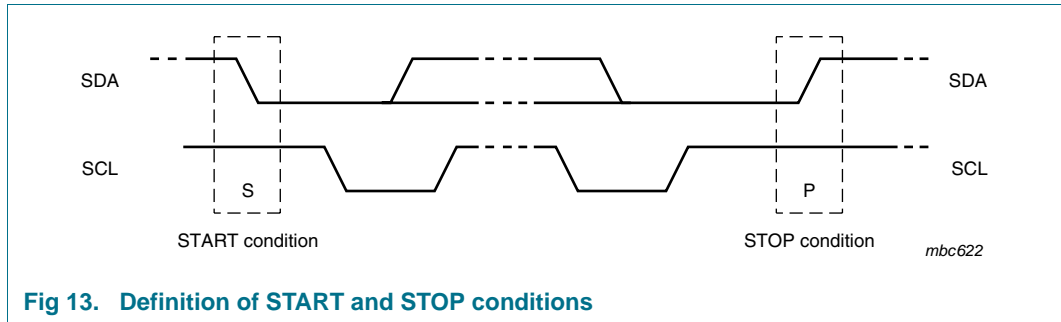

7.16.3 System configuration

A device generating a message is a transmitter; a device receiving a message is the receiver. The device that controls the message is the master, and the devices which are controlled by the master are the slaves (see [Figure 14](#)).

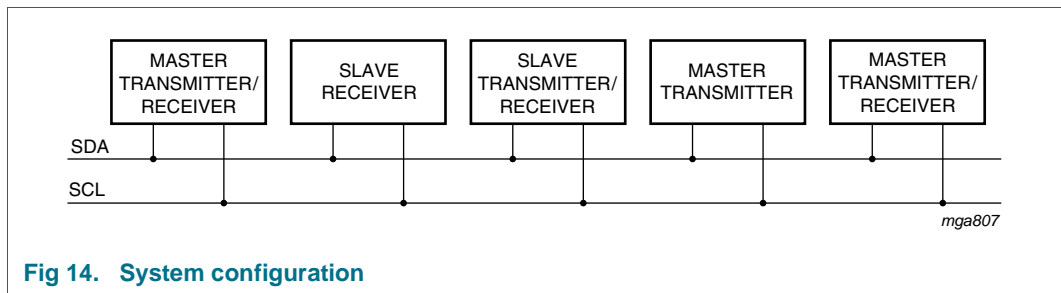

7.16.4 Acknowledge

The number of data bytes transferred between the START and STOP conditions from transmitter to receiver is unlimited. Each byte of eight bits is followed by an acknowledge cycle.

- A slave receiver, which is addressed, must generate an acknowledge after the reception of each byte.
- A master receiver must generate an acknowledge after the reception of each byte that has been clocked out of the slave transmitter.
- The device that acknowledges must pull-down the SDA line during the acknowledge clock pulse, so that the SDA line is stable LOW during the HIGH period of the acknowledge related clock pulse (set-up and hold times must be taken into consideration).
- A master receiver must signal an end of data to the transmitter by not generating an acknowledge on the last byte that has been clocked out of the slave. In this event, the transmitter must leave the data line HIGH to enable the master to generate a STOP condition.

Acknowledgement on the I²C-bus is illustrated in [Figure 15](#).

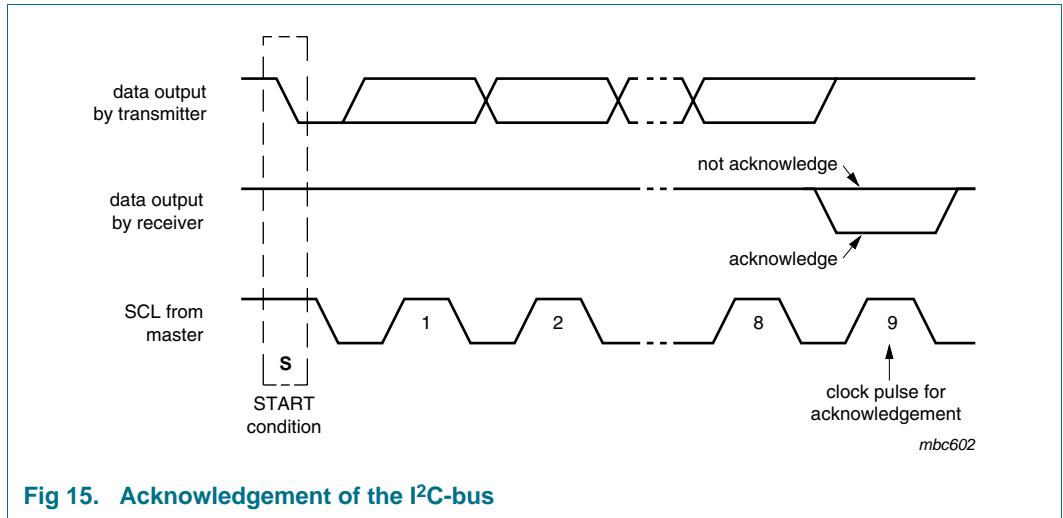

Fig 15. Acknowledgement of the I²C-bus

7.16.5 I²C-bus controller

The PCF85162 acts as an I²C-bus slave receiver. It does not initiate I²C-bus transfers or transmit data to an I²C-bus master receiver. The only data output from the PCF85162 are the acknowledge signals of the selected devices. Device selection depends on the I²C-bus slave address, on the transferred command data and on the hardware subaddress.

In single device applications, the hardware subaddress inputs A0, A1, and A2 are normally tied to V_{SS} which defines the hardware subaddress 0. In multiple device applications A0, A1, and A2 are tied to V_{SS} or V_{DD} using a binary coding scheme, so that no two devices with a common I²C-bus slave address have the same hardware subaddress.

7.16.6 Input filters

To enhance noise immunity in electrical adverse environments, RC low-pass filters are provided on the SDA and SCL lines.

7.16.7 I²C-bus protocol

Two I²C-bus slave addresses (0111 000 and 0111 001) are used to address the PCF85162. The entire I²C-bus slave address byte is shown in [Table 7](#).

Table 7. I²C slave address byte

Bit	Slave address							0 LSB
	7 MSB	6	5	4	3	2	1	
	0	1	1	1	0	0	SA0	R/W

The PCF85162 is a write-only device and will not respond to a read access, therefore bit 0 should always be logic 0. Bit 1 of the slave address byte, that a PCF85162 will respond to, is defined by the level tied to its SA0 input (V_{SS} for logic 0 and V_{DD} for logic 1).

Having two reserved slave addresses allows the following on the same I²C-bus:

- Up to 16 PCF85162 for very large LCD applications
- The use of two types of LCD multiplex drive modes

The I²C-bus protocol is shown in [Figure 16](#). The sequence is initiated with a START condition (S) from the I²C-bus master which is followed by one of two possible PCF85162 slave addresses available. All PCF85162 whose SA0 inputs correspond to bit 0 of the slave address respond by asserting an acknowledge in parallel. This I²C-bus transfer is ignored by all PCF85162 whose SA0 inputs are set to the alternative level.

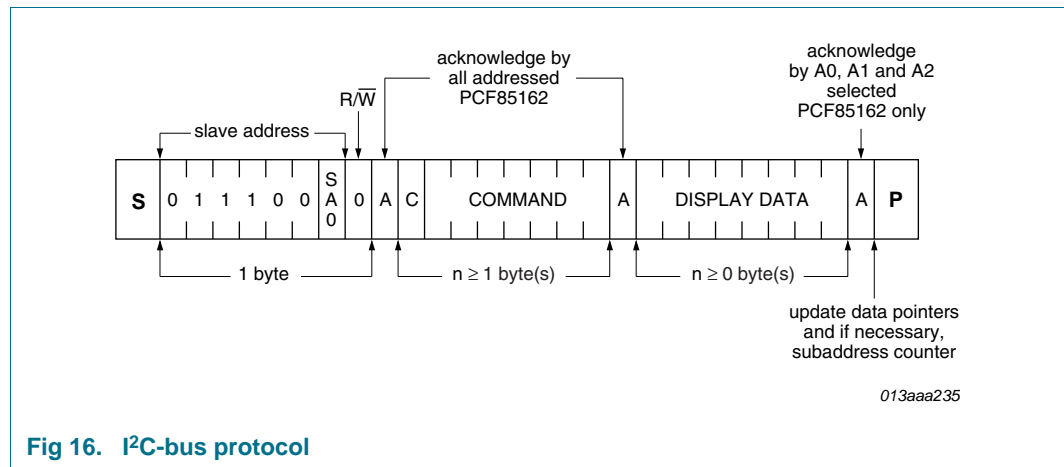

Fig 16. I²C-bus protocol

After an acknowledgement, one or more command bytes follow, that define the status of each addressed PCF85162.

The last command byte sent is identified by resetting its most significant bit, continuation bit C, (see [Figure 17](#)). The command bytes are also acknowledged by all addressed PCF85162s on the bus.

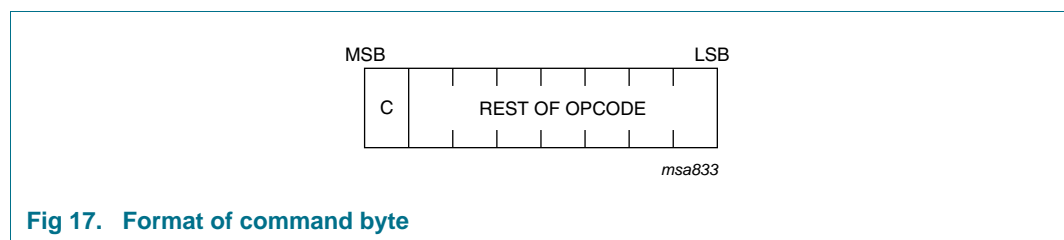

Fig 17. Format of command byte

After the last command byte, one or more display data bytes may follow. Display data bytes are stored in the display RAM at the address specified by the data pointer and the subaddress counter. Both data pointer and subaddress counter are automatically updated and the data directed to the intended PCF85162 device.

An acknowledgement after each byte is asserted only by the PCF85162 that are addressed via address lines A0, A1, and A2. After the last display byte, the I²C-bus master asserts a STOP condition (P). Alternately a START may be asserted to restart an I²C-bus access.

7.17 Command decoder

The command decoder identifies command bytes that arrive on the I²C-bus.

The commands available to the PCF85162 are defined in [Table 8](#).

Table 8. Definition of PCF85162 commands

Bit position labeled as - is not used.

Command	Operation Code								Reference
	7	6	5	4	3	2	1	0	
mode-set	C	1	0	-	E	B	M[1:0]		Table 10
load-data-pointer	C	0	0	P[4:0]					Table 11
device-select	C	1	1	0	0	A[2:0]			Table 12
bank-select	C	1	1	1	1	0	I	O	Table 13
blink-select	C	1	1	1	0	AB	BF[1:0]		Table 14

All available commands carry a continuation bit C in their most significant bit position as shown in [Figure 17](#). When this bit is set, it indicates that the next byte of the transfer to arrive will also represent a command. If this bit is reset, it indicates that the command byte is the last in the transfer. Further bytes will be regarded as display data (see [Table 9](#)).

Table 9. C bit description

Bit	Symbol	Value	Description
7	C		continue bit
		0	last control byte in the transfer; next byte will be regarded as display data
		1	control bytes continue; next byte will be a command too

Table 10. Mode-set command bit description

Bit	Symbol	Value	Description
7	C	0, 1	see Table 9
6 to 5	-	10	fixed value
4	-	-	unused
3	E		display status
		0	disabled (blank) ^[1]
		1	enabled
2	B		LCD bias configuration
		0	1/3 bias
		1	1/2 bias
1 to 0	M[1:0]		LCD drive mode selection
		01	static; BP0
		10	1:2 multiplex; BP0, BP1
		11	1:3 multiplex; BP0, BP1, BP2
		00	1:4 multiplex; BP0, BP1, BP2, BP3

[1] The possibility to disable the display allows implementation of blinking under external control.

Table 11. Load-data-pointer command bit description

Bit	Symbol	Value	Description
7	C	0, 1	see Table 9
6 to 5	-	00	fixed value
4 to 0	P[4:0]	00000 to 11111	5 bit binary value, 0 to 31; transferred to the data pointer to define one of 32 display RAM addresses

Table 12. Device-select command bit description

Bit	Symbol	Value	Description
7	C	0, 1	see Table 9
6 to 3	-	1100	fixed value
2 to 0	A[2:0]	000 to 111	3 bit binary value, 0 to 7; transferred to the subaddress counter to define one of eight hardware subaddresses

Table 13. Bank-select command bit description

Bit	Symbol	Value	Description	
			Static	1:2 multiplex ^[1]
7	C	0, 1	see Table 9	
6 to 2	-	11110	fixed value	
1	I		input bank selection ; storage of arriving display data	
		0	RAM bit 0	RAM bits 0 and 1
		1	RAM bit 2	RAM bits 2 and 3
0	O		output bank selection ; retrieval of LCD display data	
		0	RAM bit 0	RAM bits 0 and 1
		1	RAM bit 2	RAM bits 2 and 3

[1] The bank-select command has no effect in 1:3 and 1:4 multiplex drive modes.

Table 14. Blink-select command bit description

Bit	Symbol	Value	Description
7	C	0, 1	see Table 9
6 to 3	-	1110	fixed value
2	AB		blink mode selection
		0	normal blinking ^[1]
		1	alternate RAM bank blinking ^[2]
1 to 0	BF[1:0]		blink frequency selection
		00	off
		01	1
		10	2
		11	3

[1] Normal blinking is assumed when the LCD multiplex drive modes 1:3 or 1:4 are selected.

[2] Alternate RAM bank blinking does not apply in 1:3 and 1:4 multiplex drive modes.

7.18 Display controller

The display controller executes the commands identified by the command decoder. It contains the device's status registers and coordinates their effects. The display controller is also responsible for loading display data into the display RAM in the correct filling order.

8. Internal circuitry

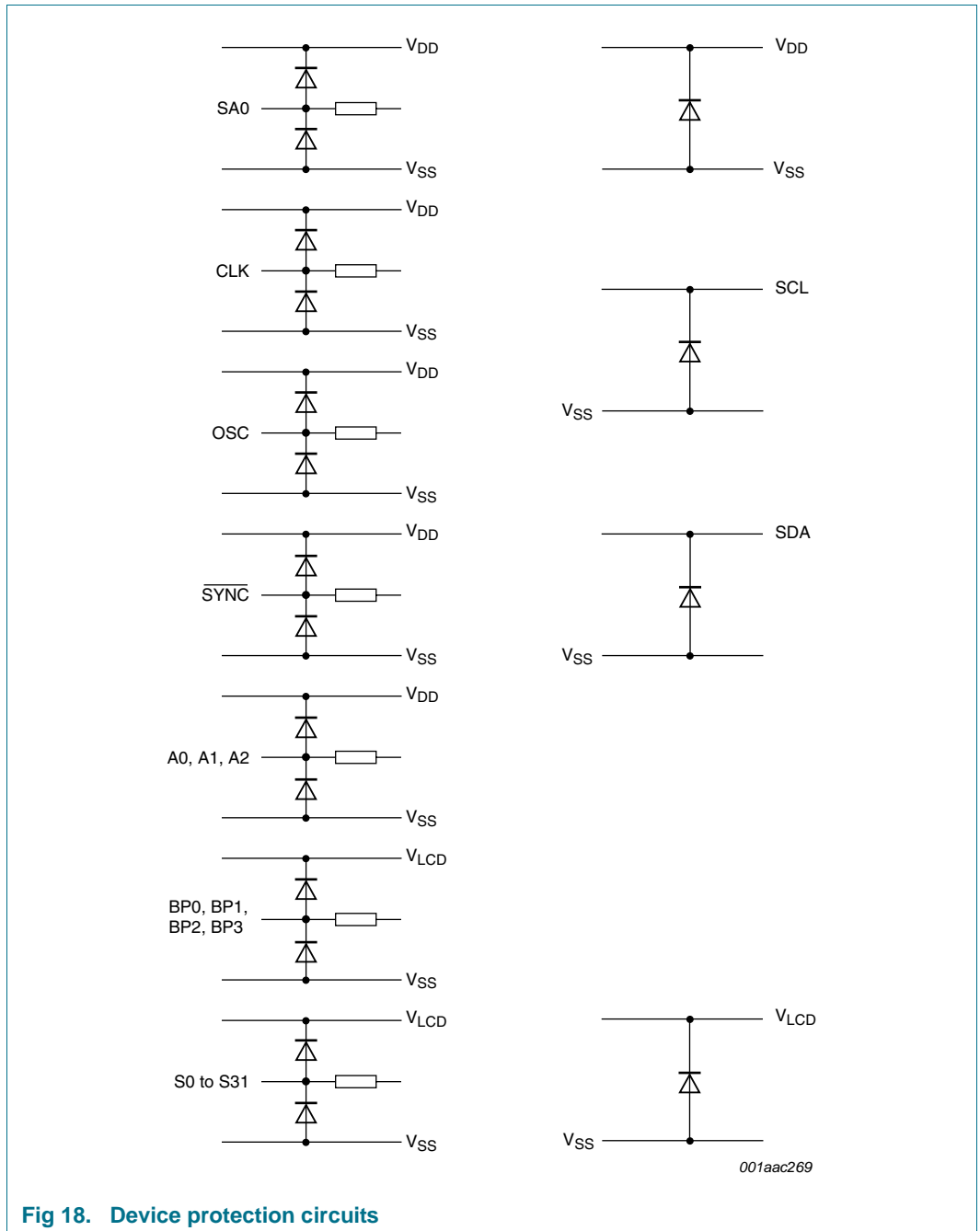

Fig 18. Device protection circuits

9. Limiting values

CAUTION



Static voltages across the liquid crystal display can build up when the LCD supply voltage (V_{LCD}) is on while the IC supply voltage (V_{DD}) is off, or vice versa. This may cause unwanted display artifacts. To avoid such artifacts, V_{LCD} and V_{DD} must be applied or removed together.

Table 15. Limiting values

In accordance with the Absolute Maximum Rating System (IEC 60134).

Symbol	Parameter	Conditions	Min	Max	Unit	
V_{DD}	supply voltage		-0.5	+6.5	V	
V_{LCD}	LCD supply voltage		-0.5	+7.5	V	
V_I	input voltage	on each of the pins CLK, SDA, SCL, SYNC, SA0, OSC, A0 to A2	-0.5	+6.5	V	
V_O	output voltage	on each of the pins S0 to S31, BP0 to BP3	-0.5	+7.5	V	
I_I	input current		-10	+10	mA	
I_O	output current		-10	+10	mA	
I_{DD}	supply current		-50	+50	mA	
$I_{DD(LCD)}$	LCD supply current		-50	+50	mA	
I_{SS}	ground supply current		-50	+50	mA	
P_{tot}	total power dissipation		-	400	mW	
P_o	output power		-	100	mW	
V_{ESD}	electrostatic discharge voltage	HBM	[1]	-	±2000	V
		CDM	[2]	-	±1000	V
		MM	[3]	-	±200	V
I_{lu}	latch-up current		[4]	-	200	mA
T_{stg}	storage temperature		[5]	-65	+150	°C
T_{oper}	operating temperature		-40	+85	°C	

[1] Pass level; Human Body Model (HBM), according to [Ref. 5 "JESD22-A114"](#).

[2] Pass level; Charged-Device Model (CDM), according to [Ref. 7 "JESD22-C101"](#).

[3] Pass level; Machine Model (MM), according to [Ref. 6 "JESD22-A115"](#)

[4] Pass level; latch-up testing according to [Ref. 8 "JESD78"](#) at maximum ambient temperature ($T_{amb(max)}$).

[5] According to the NXP store and transport requirements (see [Ref. 10 "NX3-00092"](#)) the devices have to be stored at a temperature of +8 °C to +45 °C and a humidity of 25 % to 75 %. For long term storage products deviant conditions are described in that document.

10. Static characteristics

Table 16. Static characteristics
 $V_{DD} = 1.8 \text{ V to } 5.5 \text{ V}; V_{SS} = 0 \text{ V}; V_{LCD} = 2.5 \text{ V to } 6.5 \text{ V}; T_{amb} = -40 \text{ }^{\circ}\text{C to } +85 \text{ }^{\circ}\text{C};$ unless otherwise specified.

Symbol	Parameter	Conditions	Min	Typ	Max	Unit
Supplies						
V_{DD}	supply voltage		1.8	-	5.5	V
V_{LCD}	LCD supply voltage		[1]	-	6.5	V
I_{DD}	supply current	$f_{clk(ext)} = 1536 \text{ Hz}$	[2][3]	-	20	μA
$I_{DD(LCD)}$	LCD supply current	$f_{clk(ext)} = 1536 \text{ Hz}$	[2][4]	-	60	μA
Logic						
$V_{P(POR)}$	power-on reset supply voltage		1.0	1.3	1.6	V
V_{IL}	LOW-level input voltage	on pins CLK, $\overline{\text{SYNC}}$, OSC, A0 to A2, SA0, SCL, SDA	V_{SS}	-	$0.3V_{DD}$	V
V_{IH}	HIGH-level input voltage	on pins CLK, $\overline{\text{SYNC}}$, OSC, A0 to A2, SA0, SCL, SDA	[5]	$0.7V_{DD}$	V_{DD}	V
I_{OL}	LOW-level output current	output sink current; $V_{OL} = 0.4 \text{ V}; V_{DD} = 5 \text{ V}$				
		on pins CLK and $\overline{\text{SYNC}}$	1	-	-	mA
		on pin SDA	3	-	-	mA
$I_{OH(CLK)}$	HIGH-level output current on pin CLK	output source current; $V_{OH} = 4.6 \text{ V}; V_{DD} = 5 \text{ V}$	1	-	-	mA
I_L	leakage current	$V_I = V_{DD}$ or V_{SS} ; on pins CLK, SCL, SDA, A0 to A2, and SA0	-1	-	+1	μA
$I_{L(OSC)}$	leakage current on pin OSC	$V_I = V_{DD}$	-1	-	+1	μA
C_I	input capacitance		[6]	-	7	pF
LCD outputs						
ΔV_O	output voltage variation	on pins BP0 to BP3 and S0 to S31	-100	-	+100	mV
R_O	output resistance	$V_{LCD} = 5 \text{ V}$				
		on pins BP0 to BP3	-	1.5	-	$\text{k}\Omega$
		on pins S0 to S31	-	6.0	-	$\text{k}\Omega$

[1] $V_{LCD} > 3 \text{ V}$ for $\frac{1}{3}$ bias.

[2] LCD outputs are open-circuit; inputs at V_{SS} or V_{DD} ; external clock with 50 % duty factor; I²C-bus inactive.

[3] For typical values, see [Figure 19](#)

[4] For typical values, see [Figure 20](#)

[5] I²C pins SCL and SDA have no diode to V_{DD} and when tested may therefore be driven to the V_I limiting values given in [Table 15](#) (see also [Figure 18](#)).

[6] Periodically sampled, not 100 % tested.

[7] Outputs measured one at a time.

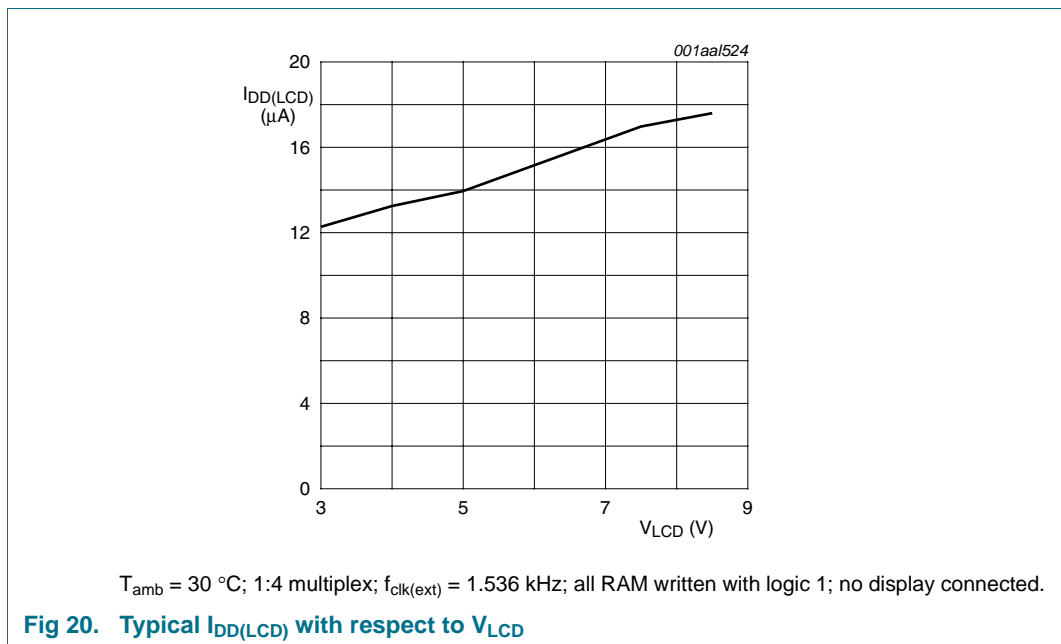
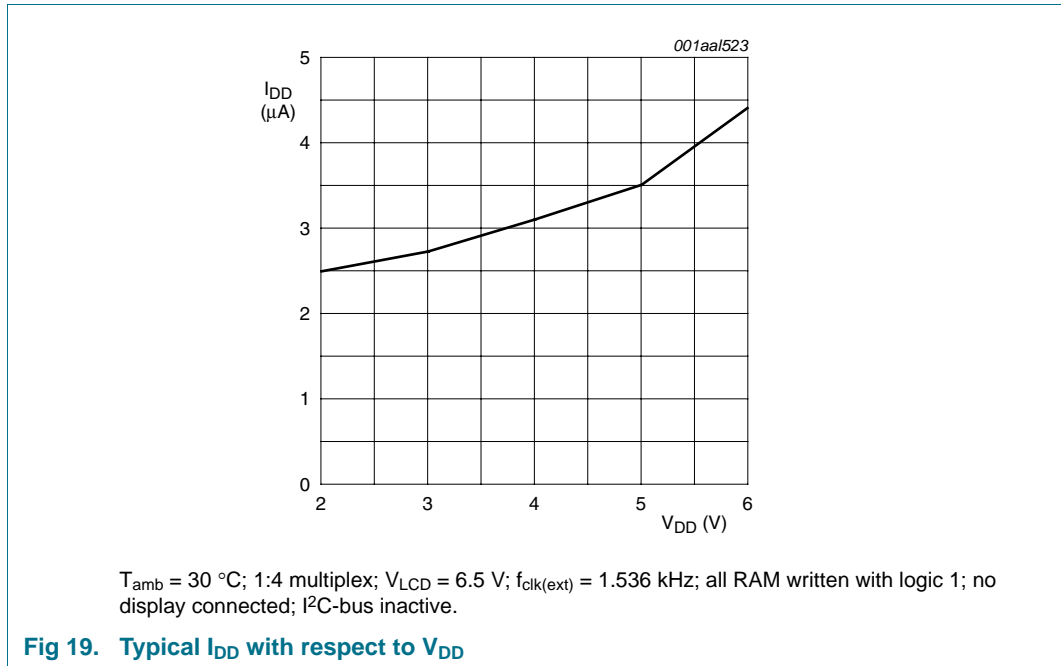

11. Dynamic characteristics

Table 17. Dynamic characteristics
 $V_{DD} = 1.8\text{ V to }5.5\text{ V}; V_{SS} = 0\text{ V}; V_{LCD} = 2.5\text{ V to }6.5\text{ V}; T_{amb} = -40\text{ }^{\circ}\text{C to }+85\text{ }^{\circ}\text{C};$ unless otherwise specified.

Symbol	Parameter	Conditions	Min	Typ	Max	Unit
Clock						
$f_{\text{clk(int)}}$	internal clock frequency	[1]	1440	1970	2640	Hz
$f_{\text{clk(ext)}}$	external clock frequency		960	-	2640	Hz
f_{fr}	frame frequency	internal clock	60	82	110	Hz
		external clock	40	-	110	Hz
$t_{\text{clk(H)}}$	HIGH-level clock time		60	-	-	μs
$t_{\text{clk(L)}}$	LOW-level clock time		60	-	-	μs
Synchronization						
$t_{\text{PD(SYNC_N)}}$	$\overline{\text{SYNC}}$ propagation delay		-	30	-	ns
$t_{\text{SYNC_NL}}$	$\overline{\text{SYNC}}$ LOW time		1	-	-	μs
$t_{\text{PD(drv)}}$	driver propagation delay	$V_{\text{LCD}} = 5\text{ V}$ [2]	-	-	30	μs
I²C-bus[3]						
Pin SCL						
f_{SCL}	SCL clock frequency		-	-	400	kHz
t_{LOW}	LOW period of the SCL clock		1.3	-	-	μs
t_{HIGH}	HIGH period of the SCL clock		0.6	-	-	μs
Pin SDA						
$t_{\text{SU;DAT}}$	data set-up time		100	-	-	ns
$t_{\text{HD;DAT}}$	data hold time		0	-	-	ns
Pins SCL and SDA						
t_{BUF}	bus free time between a STOP and START condition		1.3	-	-	μs
$t_{\text{SU;STO}}$	set-up time for STOP condition		0.6	-	-	μs
$t_{\text{HD;STA}}$	hold time (repeated) START condition		0.6	-	-	μs
$t_{\text{SU;STA}}$	set-up time for a repeated START condition		0.6	-	-	μs
t_{r}	rise time of both SDA and SCL signals	$f_{\text{SCL}} = 400\text{ kHz}$	-	-	0.3	μs
		$f_{\text{SCL}} < 125\text{ kHz}$	-	-	1.0	μs
t_{f}	fall time of both SDA and SCL signals		-	-	0.3	μs
C_{b}	capacitive load for each bus line		-	-	400	pF
$t_{\text{w(spike)}}$	spike pulse width	on the I ² C-bus	-	-	50	ns

[1] Typical output duty factor: 50 % measured at the CLK output pin.

[2] Not tested in production.

[3] All timing values are valid within the operating supply voltage and ambient temperature range and are referenced to V_{IL} and V_{IH} with an input voltage swing of V_{SS} to V_{DD} .

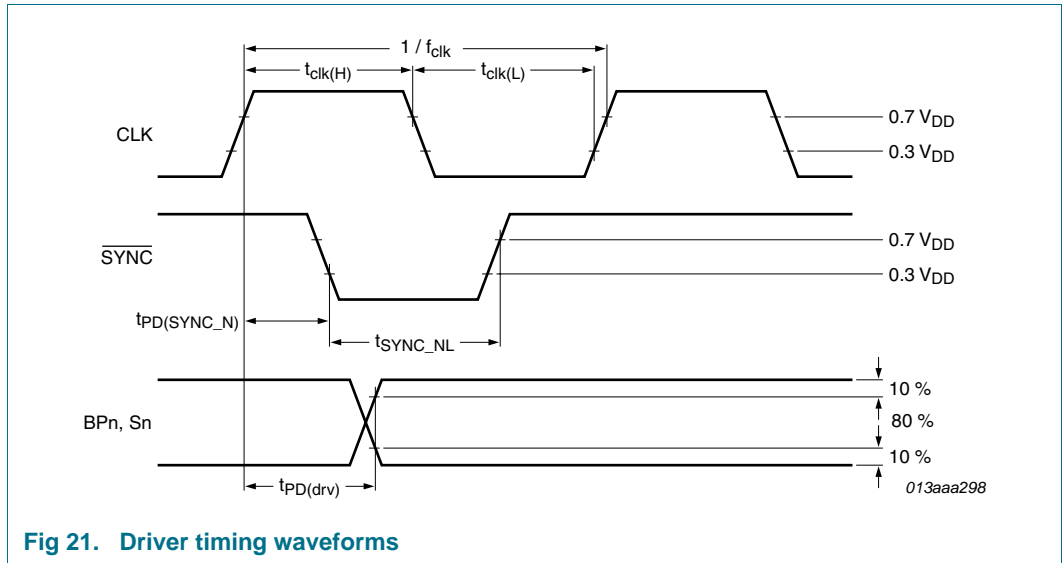

Fig 21. Driver timing waveforms

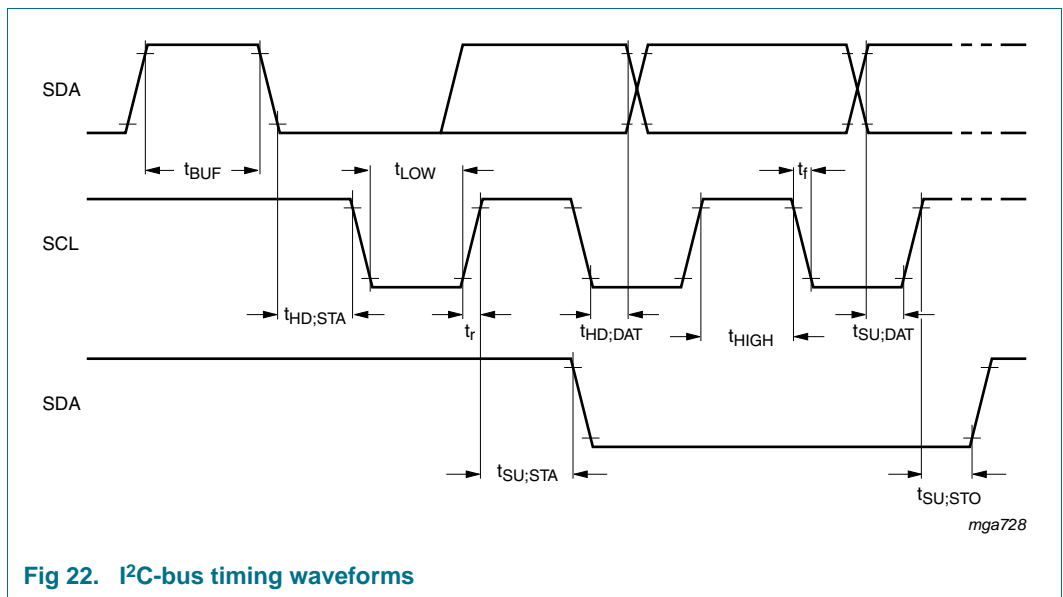

Fig 22. I²C-bus timing waveforms

12. Application information

12.1 Cascaded operation

Large display configurations of up to 16 PCF85162 can be recognized on the same I²C-bus by using the 3-bit hardware subaddress (A0, A1, and A2) and the programmable I²C-bus slave address (SA0).

Table 18. Addressing cascaded PCF85162

Cluster	Bit SA0	Pin A2	Pin A1	Pin A0	Device
1	0	0	0	0	0
		0	0	1	1
		0	1	0	2
		0	1	1	3
		1	0	0	4
		1	0	1	5
		1	1	0	6
		1	1	1	7
2	1	0	0	0	8
		0	0	1	9
		0	1	0	10
		0	1	1	11
		1	0	0	12
		1	0	1	13
		1	1	0	14
		1	1	1	15

When cascaded PCF85162 are synchronized, they can share the backplane signals from one of the devices in the cascade. Such an arrangement is cost-effective in large LCD applications since the backplane outputs of only one device need to be through-plated to the backplane electrodes of the display. The other PCF85162 of the cascade contribute additional segment outputs, but their backplane outputs are left open-circuit (see [Figure 23](#)).

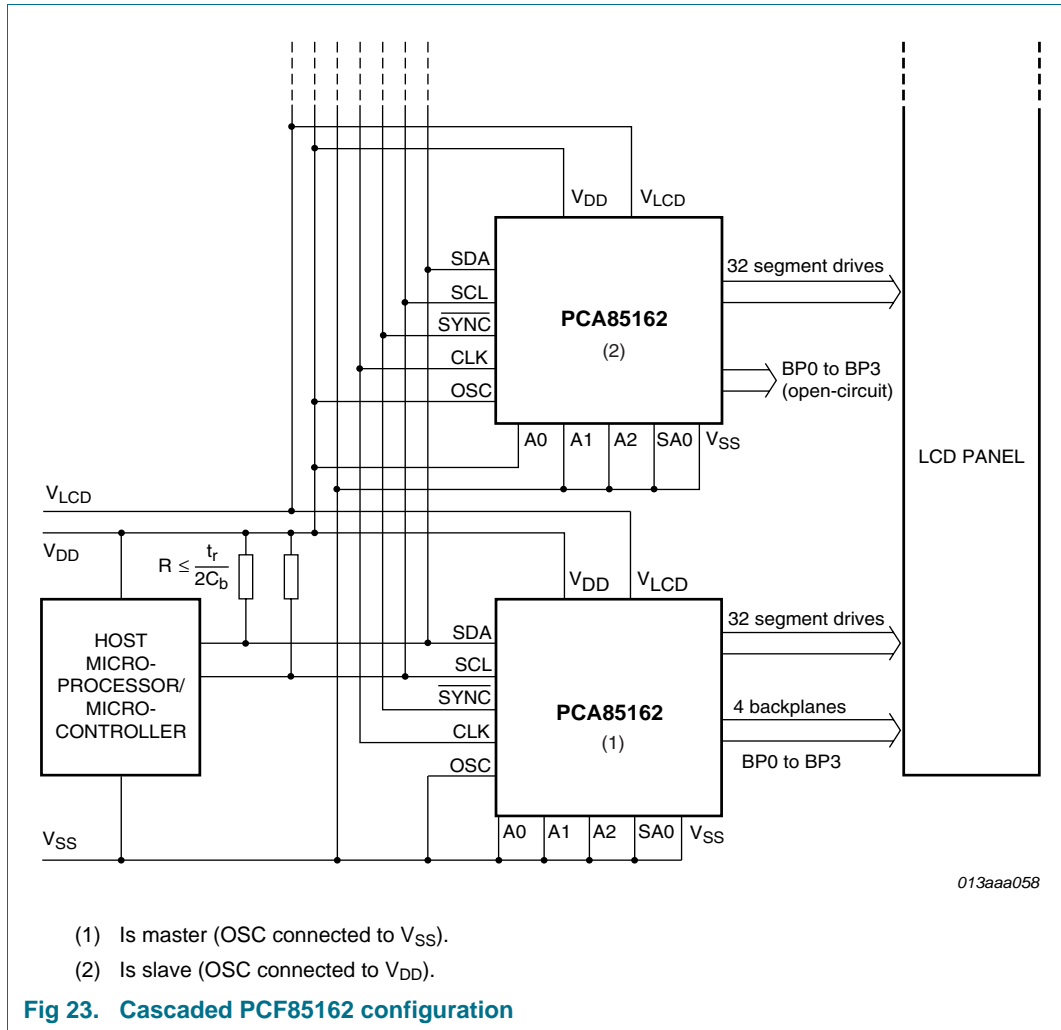

The $\overline{\text{SYNC}}$ line is provided to maintain the correct synchronization between all cascaded PCF85162. Synchronization is guaranteed after a power-on reset. The only time that $\overline{\text{SYNC}}$ is likely to be needed is if synchronization is accidentally lost (e.g. by noise in adverse electrical environments or by defining a multiplex drive mode when PCF85162 with different SA0 levels are cascaded).

$\overline{\text{SYNC}}$ is organized as an input/output pin. The output selection is realized as an open-drain driver with an internal pull-up resistor. A PCF85162 asserts the $\overline{\text{SYNC}}$ line at the onset of its last active backplane signal and monitors the $\overline{\text{SYNC}}$ line at all other times. If synchronization in the cascade is lost, it is restored by the first PCF85162 to assert $\overline{\text{SYNC}}$. The timing relationship between the backplane waveforms and the $\overline{\text{SYNC}}$ signal for the various drive modes of the PCF85162 are shown in Figure 24.

The contact resistance between the $\overline{\text{SYNC}}$ on each cascaded device must be controlled. If the resistance is too high, the device is not able to synchronize properly; this is particularly applicable to chip-on-glass applications. The maximum $\overline{\text{SYNC}}$ contact resistance allowed for the number of devices in cascade is given in Table 19.

Table 19. **SYNC contact resistance**

Number of devices	Maximum contact resistance
2	6 k Ω
3 to 5	2.2 k Ω
6 to 10	1.2 k Ω
10 to 16	700 Ω

The PCF85162 can always be cascaded with other devices of the same type or conditionally with other devices of the same family. This allows optimal drive selection for a given number of pixels to display. [Figure 21](#) and [Figure 24](#) show the timing of the synchronization signals.

In a cascaded configuration only one PCF85162 master must be used as clock source. All other PCF85162 in the cascade must be configured as slave such that they receive the clock from the master.

If an external clock source is used, all PCF85162 in the cascade must be configured such as to receive the clock from that external source (pin OSC connected to V_{DD}). Thereby it must be ensured that the clock tree is designed such that on all PCF85162 the clock propagation delay from the clock source to all PCF85162 in the cascade is as equal as possible since otherwise synchronization artefacts may occur.

In mixed cascading configurations, care has to be taken that the specifications of the individual cascaded devices are met at all times.

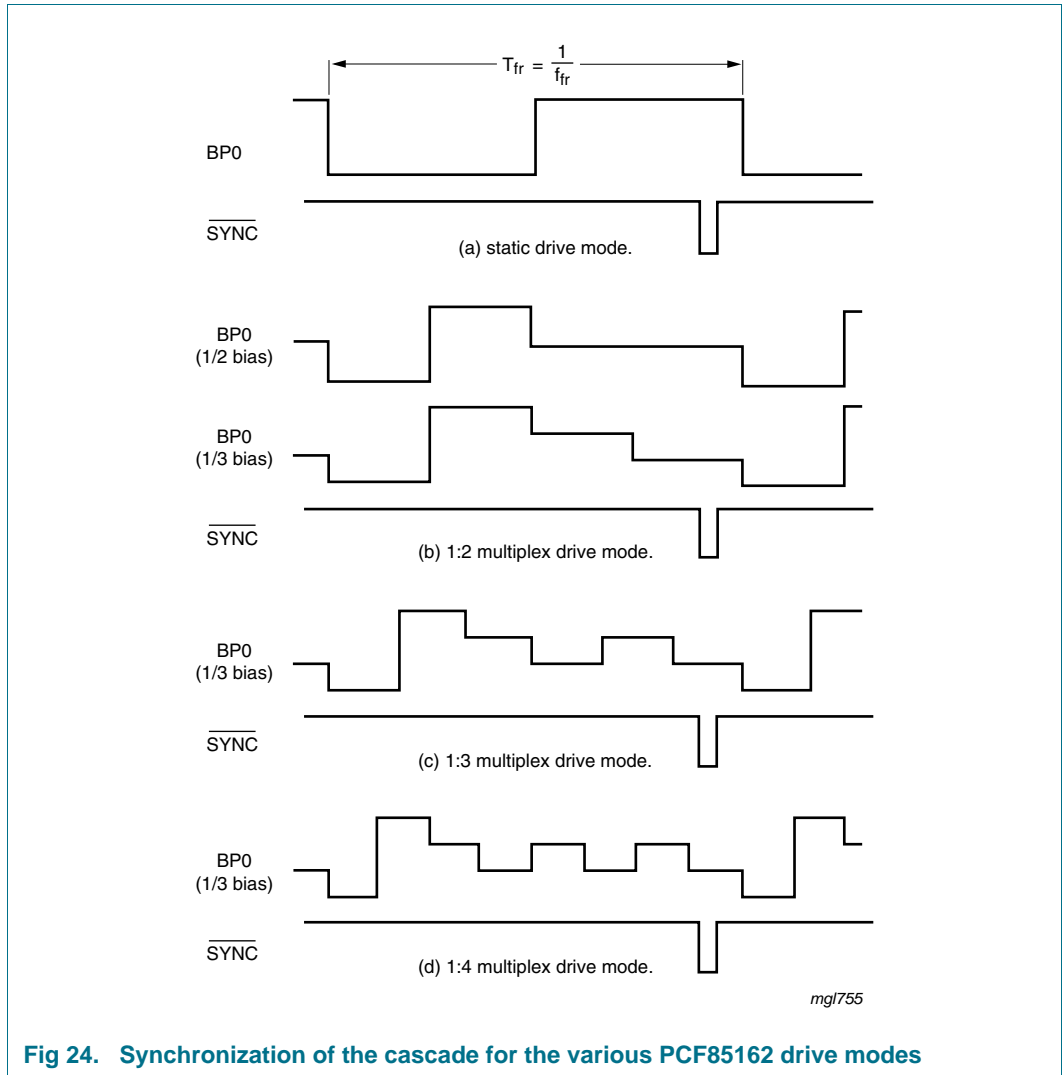

13. Package outline

TSSOP48: plastic thin shrink small outline package; 48 leads; body width 6.1 mm

SOT362-1

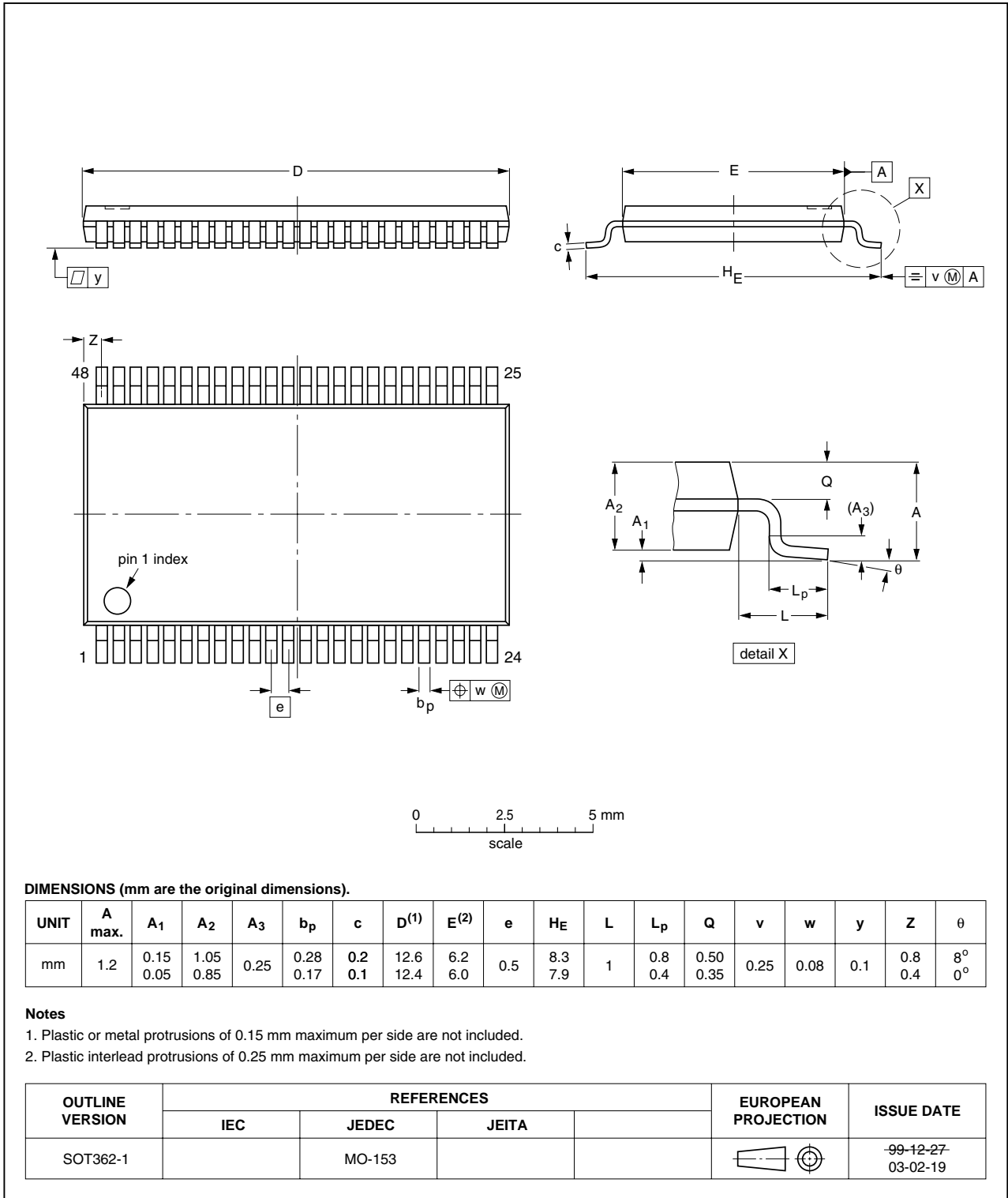

Fig 25. Package outline SOT362-1 (TSSOP48)

14. Handling information

All input and output pins are protected against ElectroStatic Discharge (ESD) under normal handling. When handling Metal-Oxide Semiconductor (MOS) devices ensure that all normal precautions are taken as described in *JESD625-A*, *IEC 61340-5* or equivalent standards.

15. Soldering of SMD packages

This text provides a very brief insight into a complex technology. A more in-depth account of soldering ICs can be found in Application Note *AN10365 "Surface mount reflow soldering description"*.

15.1 Introduction to soldering

Soldering is one of the most common methods through which packages are attached to Printed Circuit Boards (PCBs), to form electrical circuits. The soldered joint provides both the mechanical and the electrical connection. There is no single soldering method that is ideal for all IC packages. Wave soldering is often preferred when through-hole and Surface Mount Devices (SMDs) are mixed on one printed wiring board; however, it is not suitable for fine pitch SMDs. Reflow soldering is ideal for the small pitches and high densities that come with increased miniaturization.

15.2 Wave and reflow soldering

Wave soldering is a joining technology in which the joints are made by solder coming from a standing wave of liquid solder. The wave soldering process is suitable for the following:

- Through-hole components
- Leaded or leadless SMDs, which are glued to the surface of the printed circuit board

Not all SMDs can be wave soldered. Packages with solder balls, and some leadless packages which have solder lands underneath the body, cannot be wave soldered. Also, leaded SMDs with leads having a pitch smaller than ~0.6 mm cannot be wave soldered, due to an increased probability of bridging.

The reflow soldering process involves applying solder paste to a board, followed by component placement and exposure to a temperature profile. Leaded packages, packages with solder balls, and leadless packages are all reflow solderable.

Key characteristics in both wave and reflow soldering are:

- Board specifications, including the board finish, solder masks and vias
- Package footprints, including solder thieves and orientation
- The moisture sensitivity level of the packages
- Package placement
- Inspection and repair
- Lead-free soldering versus SnPb soldering

15.3 Wave soldering

Key characteristics in wave soldering are:

- Process issues, such as application of adhesive and flux, clinching of leads, board transport, the solder wave parameters, and the time during which components are exposed to the wave
- Solder bath specifications, including temperature and impurities

15.4 Reflow soldering

Key characteristics in reflow soldering are:

- Lead-free versus SnPb soldering; note that a lead-free reflow process usually leads to higher minimum peak temperatures (see [Figure 26](#)) than a SnPb process, thus reducing the process window
- Solder paste printing issues including smearing, release, and adjusting the process window for a mix of large and small components on one board
- Reflow temperature profile; this profile includes preheat, reflow (in which the board is heated to the peak temperature) and cooling down. It is imperative that the peak temperature is high enough for the solder to make reliable solder joints (a solder paste characteristic). In addition, the peak temperature must be low enough that the packages and/or boards are not damaged. The peak temperature of the package depends on package thickness and volume and is classified in accordance with [Table 20](#) and [21](#)

Table 20. SnPb eutectic process (from J-STD-020C)

Package thickness (mm)	Package reflow temperature (°C)	
	Volume (mm ³)	
	< 350	≥ 350
< 2.5	235	220
≥ 2.5	220	220

Table 21. Lead-free process (from J-STD-020C)

Package thickness (mm)	Package reflow temperature (°C)		
	Volume (mm ³)		
	< 350	350 to 2000	> 2000
< 1.6	260	260	260
1.6 to 2.5	260	250	245
> 2.5	250	245	245

Moisture sensitivity precautions, as indicated on the packing, must be respected at all times.

Studies have shown that small packages reach higher temperatures during reflow soldering, see [Figure 26](#).

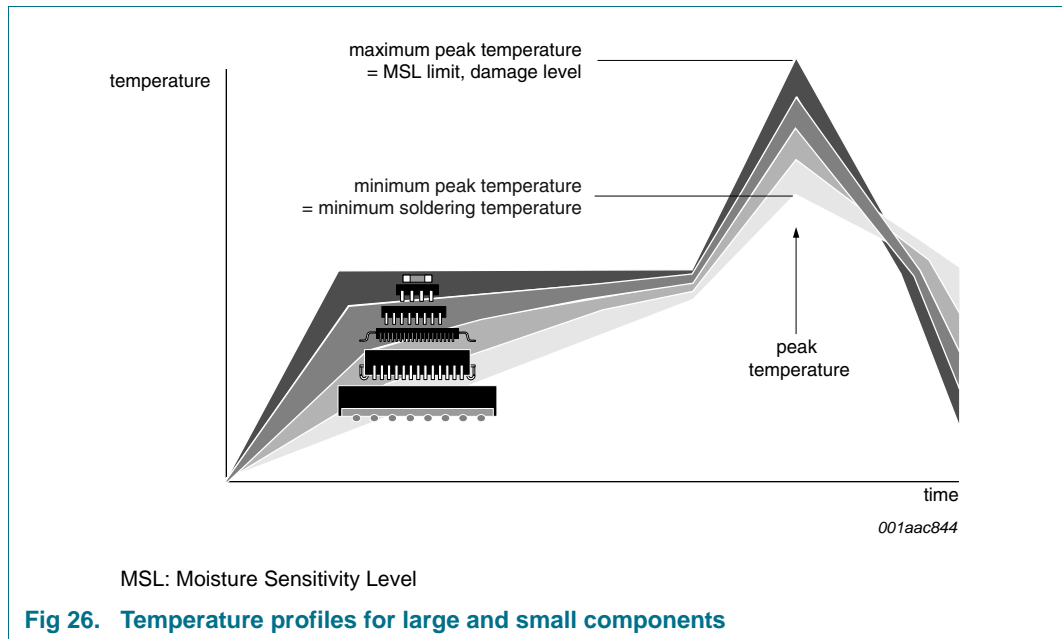

For further information on temperature profiles, refer to Application Note AN10365 “Surface mount reflow soldering description”.

16. Abbreviations

Table 22. Abbreviations

Acronym	Description
CMOS	Complementary Metal-Oxide Semiconductor
CDM	Charged-Device Model
DC	Direct Current
HBM	Human Body Model
I ² C	Inter-Integrated Circuit
IC	Integrated Circuit
LCD	Liquid Crystal Display
MM	Machine Model
MSL	Moisture Sensitivity Level
PCB	Printed-Circuit Board
RAM	Random Access Memory
RC	Resistance and Capacitance
RMS	Root Mean Square
SCL	Serial Clock Line
SDA	Serial DATA line
SMD	Surface-Mount Device

17. References

- [1] **AN10365** — Surface mount reflow soldering description
- [2] **IEC 60134** — Rating systems for electronic tubes and valves and analogous semiconductor devices
- [3] **IEC 61340-5** — Protection of electronic devices from electrostatic phenomena
- [4] **IPC/JEDEC J-STD-020D** — Moisture/Reflow Sensitivity Classification for Nonhermetic Solid State Surface Mount Devices
- [5] **JESD22-A114** — Electrostatic Discharge (ESD) Sensitivity Testing Human Body Model (HBM)
- [6] **JESD22-A115** — Electrostatic Discharge (ESD) Sensitivity Testing Machine Model (MM)
- [7] **JESD22-C101** — Field-Induced Charged-Device Model Test Method for Electrostatic-Discharge-Withstand Thresholds of Microelectronic Components
- [8] **JESD78** — IC Latch-Up Test
- [9] **JESD625-A** — Requirements for Handling Electrostatic-Discharge-Sensitive (ESDS) Devices
- [10] **NX3-00092** — NXP store and transport requirements
- [11] **SNV-FA-01-02** — Marking Formats Integrated Circuits
- [12] **UM10204** — I²C-bus specification and user manual

18. Revision history

Table 23. Revision history

Document ID	Release date	Data sheet status	Change notice	Supersedes
PCF85162_2	20100507	Product data sheet	-	PCF85162_1
Modifications:	<ul style="list-style-type: none">• The format of this data sheet has been redesigned to comply with the new identity guidelines of NXP Semiconductors.• Legal texts have been adapted to the new company name where appropriate.• Corrected ESD values• Added Figure 3, Figure 19 and Figure 20			
PCF85162_1	20100107	Product data sheet	-	-

19. Legal information

19.1 Data sheet status

Document status ^{[1][2]}	Product status ^[3]	Definition
Objective [short] data sheet	Development	This document contains data from the objective specification for product development.
Preliminary [short] data sheet	Qualification	This document contains data from the preliminary specification.
Product [short] data sheet	Production	This document contains the product specification.

[1] Please consult the most recently issued document before initiating or completing a design.

[2] The term 'short data sheet' is explained in section "Definitions".

[3] The product status of device(s) described in this document may have changed since this document was published and may differ in case of multiple devices. The latest product status information is available on the Internet at URL <http://www.nxp.com>.

19.2 Definitions

Draft — The document is a draft version only. The content is still under internal review and subject to formal approval, which may result in modifications or additions. NXP Semiconductors does not give any representations or warranties as to the accuracy or completeness of information included herein and shall have no liability for the consequences of use of such information.

Short data sheet — A short data sheet is an extract from a full data sheet with the same product type number(s) and title. A short data sheet is intended for quick reference only and should not be relied upon to contain detailed and full information. For detailed and full information see the relevant full data sheet, which is available on request via the local NXP Semiconductors sales office. In case of any inconsistency or conflict with the short data sheet, the full data sheet shall prevail.

Product specification — The information and data provided in a Product data sheet shall define the specification of the product as agreed between NXP Semiconductors and its customer, unless NXP Semiconductors and customer have explicitly agreed otherwise in writing. In no event however, shall an agreement be valid in which the NXP Semiconductors product is deemed to offer functions and qualities beyond those described in the Product data sheet.

19.3 Disclaimers

Limited warranty and liability — Information in this document is believed to be accurate and reliable. However, NXP Semiconductors does not give any representations or warranties, expressed or implied, as to the accuracy or completeness of such information and shall have no liability for the consequences of use of such information.

In no event shall NXP Semiconductors be liable for any indirect, incidental, punitive, special or consequential damages (including - without limitation - lost profits, lost savings, business interruption, costs related to the removal or replacement of any products or rework charges) whether or not such damages are based on tort (including negligence), warranty, breach of contract or any other legal theory.

Notwithstanding any damages that customer might incur for any reason whatsoever, NXP Semiconductors' aggregate and cumulative liability towards customer for the products described herein shall be limited in accordance with the *Terms and conditions of commercial sale* of NXP Semiconductors.

Right to make changes — NXP Semiconductors reserves the right to make changes to information published in this document, including without limitation specifications and product descriptions, at any time and without notice. This document supersedes and replaces all information supplied prior to the publication hereof.

Suitability for use — NXP Semiconductors products are not designed, authorized or warranted to be suitable for use in life support, life-critical or safety-critical systems or equipment, nor in applications where failure or

malfunction of an NXP Semiconductors product can reasonably be expected to result in personal injury, death or severe property or environmental damage. NXP Semiconductors accepts no liability for inclusion and/or use of NXP Semiconductors products in such equipment or applications and therefore such inclusion and/or use is at the customer's own risk.

Applications — Applications that are described herein for any of these products are for illustrative purposes only. NXP Semiconductors makes no representation or warranty that such applications will be suitable for the specified use without further testing or modification.

Customers are responsible for the design and operation of their applications and products using NXP Semiconductors products, and NXP Semiconductors accepts no liability for any assistance with applications or customer product design. It is customer's sole responsibility to determine whether the NXP Semiconductors product is suitable and fit for the customer's applications and products planned, as well as for the planned application and use of customer's third party customer(s). Customers should provide appropriate design and operating safeguards to minimize the risks associated with their applications and products.

NXP Semiconductors does not accept any liability related to any default, damage, costs or problem which is based on any weakness or default in the customer's applications or products, or the application or use by customer's third party customer(s). Customer is responsible for doing all necessary testing for the customer's applications and products using NXP Semiconductors products in order to avoid a default of the applications and the products or of the application or use by customer's third party customer(s). NXP does not accept any liability in this respect.

Limiting values — Stress above one or more limiting values (as defined in the Absolute Maximum Ratings System of IEC 60134) will cause permanent damage to the device. Limiting values are stress ratings only and (proper) operation of the device at these or any other conditions above those given in the Recommended operating conditions section (if present) or the Characteristics sections of this document is not warranted. Constant or repeated exposure to limiting values will permanently and irreversibly affect the quality and reliability of the device.

Terms and conditions of commercial sale — NXP Semiconductors products are sold subject to the general terms and conditions of commercial sale, as published at <http://www.nxp.com/profile/terms>, unless otherwise agreed in a valid written individual agreement. In case an individual agreement is concluded only the terms and conditions of the respective agreement shall apply. NXP Semiconductors hereby expressly objects to applying the customer's general terms and conditions with regard to the purchase of NXP Semiconductors products by customer.

No offer to sell or license — Nothing in this document may be interpreted or construed as an offer to sell products that is open for acceptance or the grant, conveyance or implication of any license under any copyrights, patents or other industrial or intellectual property rights.

Export control — This document as well as the item(s) described herein may be subject to export control regulations. Export might require a prior authorization from national authorities.

Non-automotive qualified products — Unless this data sheet expressly states that this specific NXP Semiconductors product is automotive qualified, the product is not suitable for automotive use. It is neither qualified nor tested in accordance with automotive testing or application requirements. NXP Semiconductors accepts no liability for inclusion and/or use of non-automotive qualified products in automotive equipment or applications.

In the event that customer uses the product for design-in and use in automotive applications to automotive specifications and standards, customer (a) shall use the product without NXP Semiconductors' warranty of the product for such automotive applications, use and specifications, and (b) whenever customer uses the product for automotive applications beyond NXP Semiconductors' specifications such use shall be solely at customer's

own risk, and (c) customer fully indemnifies NXP Semiconductors for any liability, damages or failed product claims resulting from customer design and use of the product for automotive applications beyond NXP Semiconductors' standard warranty and NXP Semiconductors' product specifications.

19.4 Trademarks

Notice: All referenced brands, product names, service names and trademarks are the property of their respective owners.

I²C-bus — logo is a trademark of NXP B.V.

20. Contact information

For more information, please visit: <http://www.nxp.com>

For sales office addresses, please send an email to: salesaddresses@nxp.com

21. Contents

1	General description	1	13	Package outline	35
2	Features and benefits	1	14	Handling information	36
3	Ordering information	2	15	Soldering of SMD packages	36
4	Marking	2	15.1	Introduction to soldering	36
5	Block diagram	2	15.2	Wave and reflow soldering	36
6	Pinning information	3	15.3	Wave soldering	37
6.1	Pinning	3	15.4	Reflow soldering	37
6.2	Pin description	4	16	Abbreviations	38
7	Functional description	5	17	References	39
7.1	Power-on reset	6	18	Revision history	40
7.2	LCD bias generator	6	19	Legal information	41
7.3	LCD voltage selector	7	19.1	Data sheet status	41
7.4	LCD drive mode waveforms	9	19.2	Definitions	41
7.4.1	Static drive mode	9	19.3	Disclaimers	41
7.4.2	1:2 Multiplex drive mode	10	19.4	Trademarks	42
7.4.3	1:3 Multiplex drive mode	12	20	Contact information	42
7.4.4	1:4 Multiplex drive mode	13	21	Contents	43
7.5	Oscillator	14			
7.5.1	Internal clock	14			
7.5.2	External clock	14			
7.6	Timing	14			
7.7	Display register	14			
7.8	Segment outputs	14			
7.9	Backplane outputs	14			
7.10	Display RAM	15			
7.11	Data pointer	17			
7.12	Subaddress counter	17			
7.13	Output bank selector	18			
7.14	Input bank selector	18			
7.15	Blinker	18			
7.16	Characteristics of the I ² C-bus	19			
7.16.1	Bit transfer	19			
7.16.2	START and STOP conditions	19			
7.16.3	System configuration	20			
7.16.4	Acknowledge	20			
7.16.5	I ² C-bus controller	21			
7.16.6	Input filters	21			
7.16.7	I ² C-bus protocol	21			
7.17	Command decoder	23			
7.18	Display controller	25			
8	Internal circuitry	25			
9	Limiting values	26			
10	Static characteristics	27			
11	Dynamic characteristics	29			
12	Application information	31			
12.1	Cascaded operation	31			

Please be aware that important notices concerning this document and the product(s) described herein, have been included in section 'Legal information'.