

ZXCT1008

AUTOMOTIVE HIGH-SIDE CURRENT MONITOR

DESCRIPTION

The ZXCT1008 is a high side current sense monitor. Using this device eliminates the need to disrupt the ground plane when sensing a load current.

It takes a high side voltage developed across a current shunt resistor and translates it into a proportional output current.

A user defined output resistor scales the output current into a ground-referenced voltage.

The wide input voltage range of 20V down to as low as 2.5V make it suitable for a range of applications. The ability to withstand high voltage transients and reverse polarity connection, makes this part very suitable for automotive and other transient rich environments.

FEATURES

- Low cost, accurate high-side current sensing
- -40 to +125°C temperature range
- Up to 500mV sense voltage
- 2.5V – 20V supply range
- 4µA quiescent current
- 1% typical accuracy
- SOT23

ORDERING INFORMATION

DEVICE	REEL SIZE	TAPE WIDTH	QUANTITY PER REEL
ZXCT1008FTA	7"	8mm	3,000 units

DEVICE MARKING

- 108

APPLICATIONS

- Automotive current measurement
- DC motor and solenoid control
- Over current monitor
- Power management

APPLICATION CIRCUIT

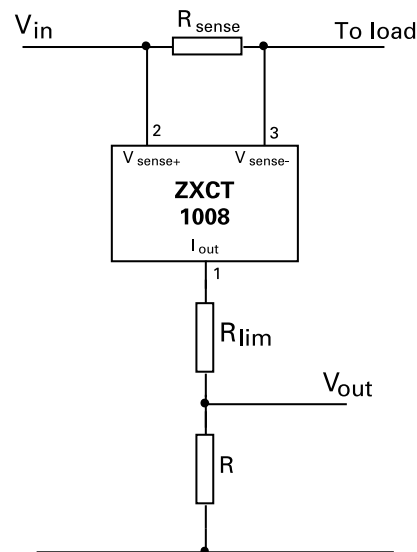

ZXCT1008

ABSOLUTE MAXIMUM RATINGS

Voltage on any pin	-0.6V to 20V (relative to I _{out})
Continuous output current, I _{OUT} ,	10mA
Continuous sense voltage, V _{SENSE} [†] ,	-0.5V to +5V
Operating temperature, T _A ,	-40 to 125°C
Storage temperature	-55 to 150°C
Package power dissipation (T _A = 25°C)	450mW Derate to zero at 150°C

Operation above the absolute maximum rating may cause device failure. Operation at the absolute maximum ratings, for extended periods, may reduce device reliability.

ELECTRICAL CHARACTERISTICS

Test Conditions T_A = 25°C, V_{in} = 5V, R_{out} = 100Ω.

SYMBOL	PARAMETER	CONDITIONS	LIMITS			UNIT
			Min	Typ	Max	
V _{in}	V _{CC} range		2.5		20	V
I _{out} ¹	Output current	V _{sense} =0V	1	4	15	μA
		V _{sense} =10mV	90	104	120	μA
		V _{sense} =100mV	0.975	1.0	1.025	mA
		V _{sense} =200mV	1.95	2.0	2.05	mA
		V _{sense} =500mV	4.8	5.0	5.2	mA
V _{sense} [†]	Sense voltage		0		500	mV
I _{sense} ⁻	V _{sense} ⁻ input current				100	nA
Acc	Accuracy	R _{sense} = 0.1Ω V _{sense} =200mV	-2.5		2.5	%
G _m	Transconductance, I _{out} / V _{sense}			10000		μA/V
BW	Bandwidth	V _{SENSE(DC)} = 10mV, Pin = -40dBm ‡		300		kHz
		V _{SENSE(DC)} = 100mV, Pin = -20dBm ‡		2		MH

¹ Includes input offset voltage contribution

[†] V_{SENSE} is defined as the differential voltage between V_{SENSE+} and V_{SENSE-}.

$$\begin{aligned}
 V_{SENSE} &= V_{SENSE+} - V_{SENSE-} \\
 &= V_{IN} - V_{LOAD} \\
 &= I_{LOAD} \times R_{SENSE}
 \end{aligned}$$

‡ -20dBm=63mVp-p into 50Ω

TYPICAL CHARACTERISTICS

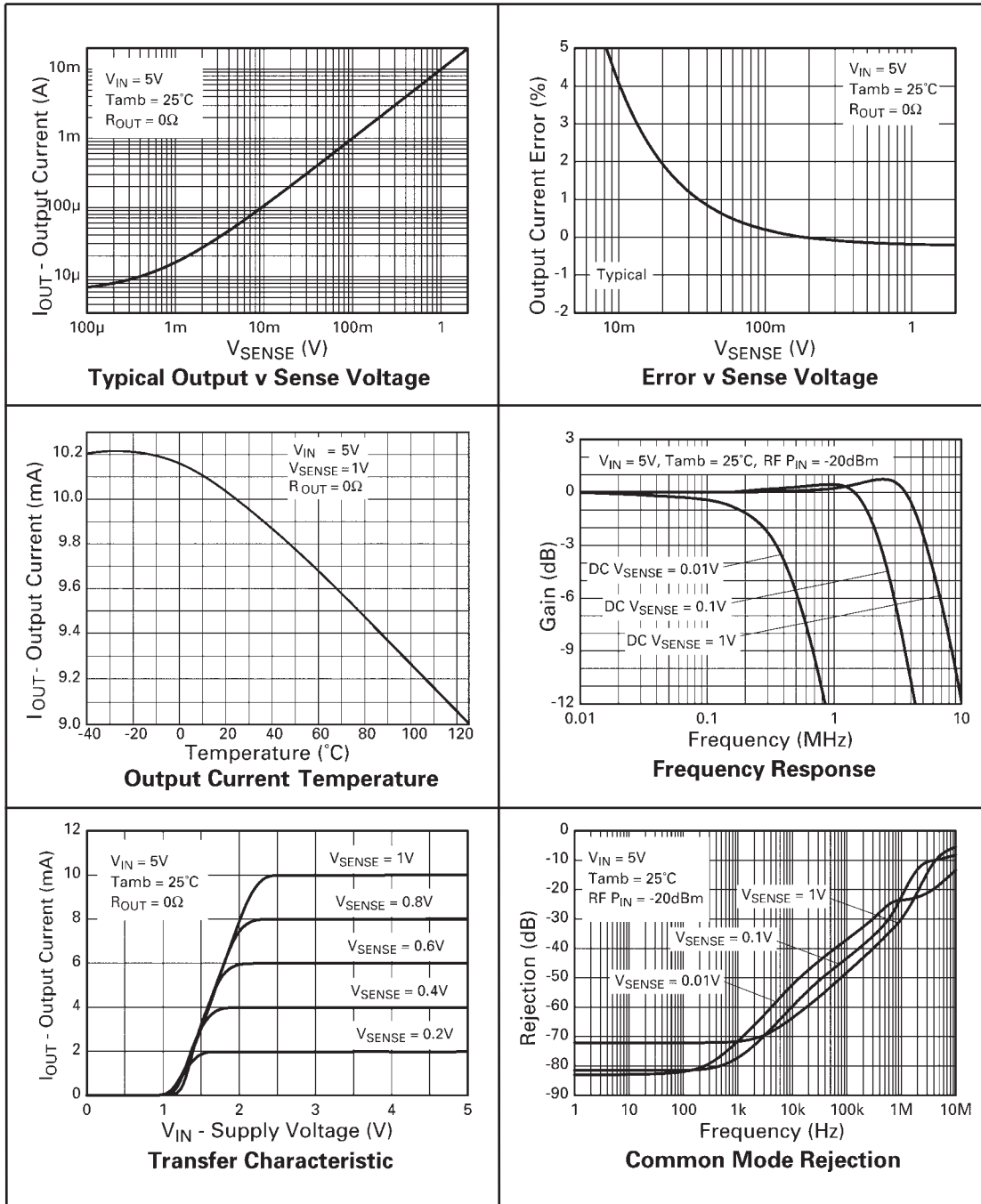

ZXCT1008

TYPICAL CHARACTERISTICS (Cont.)

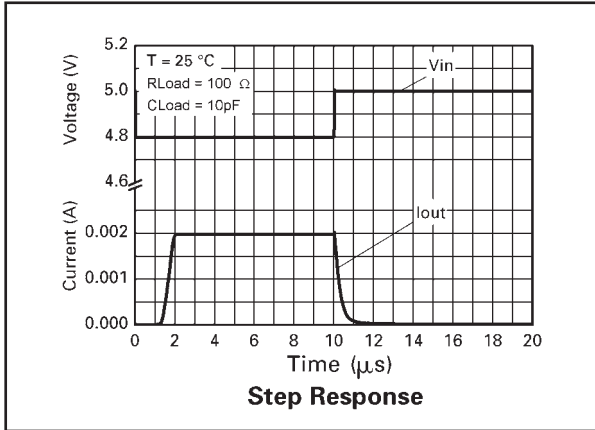

SCHEMATIC DIAGRAM

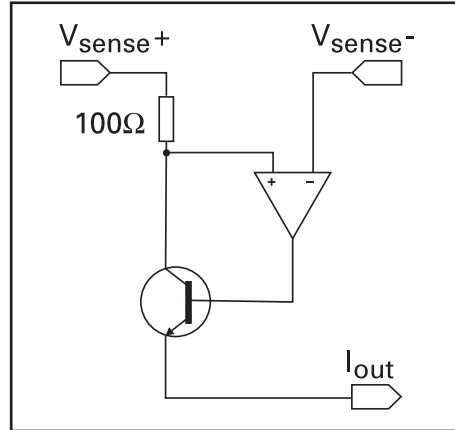

PIN DESCRIPTION

Pin Name	Pin Function
V_{sense+}	Supply voltage
V_{sense-}	Connection to load/battery
I_{out}	Output current, proportional to $V_{in} - V_{load}$

CONNECTION DIAGRAM

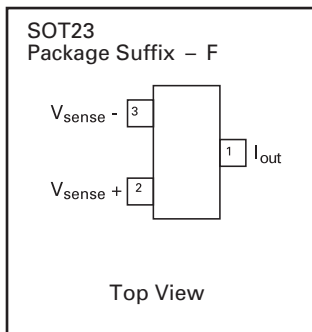

ZXCT1008

POWER DISSIPATION

The maximum allowable power dissipation of the device for normal operation (P_{max}), is a function of the package junction to ambient thermal resistance (θ_{ja}), maximum junction temperature (T_{jmax}), and ambient temperature (T_{amb}), according to the expression:

$$P_{max} = (T_{jmax} - T_{amb}) / \theta_{ja}$$

The device power dissipation, P_D is given by the expression:

$$P_D = I_{out} \cdot (V_{in} - V_{out}) \text{ Watts}$$

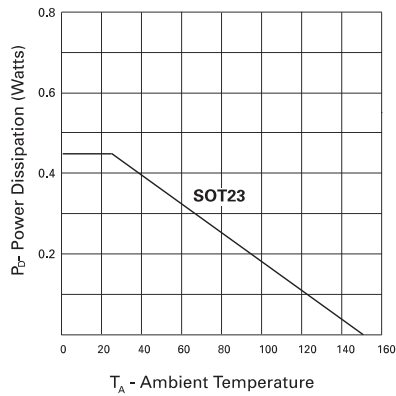

APPLICATIONS INFORMATION

The following lines describe how to scale a load current to an output voltage.

$$V_{sense} = V_{in} - V_{load}$$
$$V_{out} = 0.01 \times V_{sense} \times R_{out}^1$$

E.g.

A 1A current is to be represented by a 100mV output voltage:

- 1) Choose the value of R_{sense} to give 50mV > $V_{sense} > 500mV$ at full load.

For example $V_{sense} = 100mV$ at 1.0A.
 $R_{sense} = 0.1/1.0 \Rightarrow 0.1 \Omega$

- 2) Choose R_{out} to give $V_{out} = 100mV$, when $V_{sense} = 100mV$.

Rearranging ¹ for R_{out} gives:
 $R_{out} = V_{out} / (V_{sense} \times 0.01)$

$$R_{out} = 0.1 / (0.1 \times 0.01) = 100 \Omega$$

ZXCT1008

Where R_{load} represents any load including DC motors, a charging battery or further circuitry that requires monitoring, R_{sense} can be selected on specific requirements of accuracy, size and power rating.

An additional resistor, R_{lim} can be added in series with R_{out} (figure 1.0), to limit the current from I_{out} . Any circuit connected to V_{out} will be protected from input voltage transients. This can be of particular use in automotive applications where load dump and other common transients need to be considered. The zener Z1 provides additional protection for local dump, reverse battery and high voltage transient incidents.

Assuming the worst case condition of $V_{out} = 0V$; providing a low impedance to a transient, the minimum value of R_{lim} is given by:-

$$R_{lim}(\min) = \frac{V_{pk} - V_{max}}{I_{pk}}$$

- V_{pk} = Peak transient voltage to be withstood
- V_{max} = Maximum working Voltage = 20V
- I_{pk} = Peak output current = 40mA

The maximum value of R_{lim} is set by $V_{in}(\min)$, $V_{out}(\max)$ and the dropout voltage (see transfer characteristic on page 3) of the ZXCT1009 :-

$$R_{lim}(\max) = \frac{R_{out}[V_{in}(\min) - (V_{dp} + V_{out}(\max))]}{V_{out}(\max)}$$

- $V_{in}(\min)$ = Minimum Supply Operating Voltage
- V_{dp} = Dropout Voltage
- $V_{out}(\max)$ = Maximum Operating Output Voltage

TYPICAL AUTOMOTIVE CIRCUIT APPLICATION

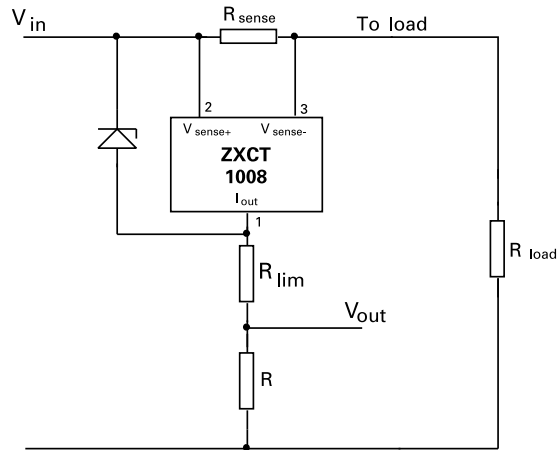

Figure 1.0
ZXCT1009 with additional current limiting Resistor R_{lim} and zener Z1

APPLICATIONS INFORMATION

ZXCT1008

PCB trace shunt resistor for low cost solution.

The figure below shows output characteristics of the device when using a PCB resistive trace for a low cost solution in replacement for a conventional shunt resistor. The graph shows the linear rise in voltage across the resistor due to the PTC of the material and demonstrates how this rise in resistance value over temperature compensates for the NTC of the device.

The figure opposite shows a PCB layout suggestion. The resistor section is 25mm x 0.25mm giving approximately 150mΩ using 1oz copper. The data for the normalised graph was obtained using a 1A load current and a 100Ω output resistor. An electronic version of the PCB layout is available at www.zetex.com/isense

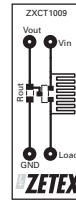

Actual Size

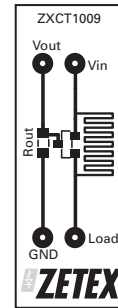

Layout shows area of shunt resistor compared to SOT23 package. Not actual size

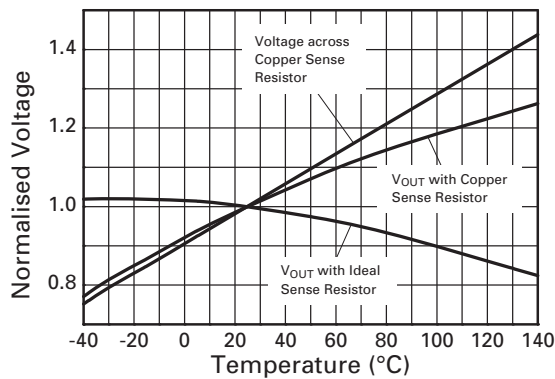

Effect of Sense Resistor Material on Temperature Performance

ZXCT1008

Definitions

Product change

Zetex Semiconductors reserves the right to alter, without notice, specifications, design, price or conditions of supply of any product or service. Customers are solely responsible for obtaining the latest relevant information before placing orders.

Applications disclaimer

The circuits in this design/application note are offered as design ideas. It is the responsibility of the user to ensure that the circuit is fit for the user's application and meets with the user's requirements. No representation or warranty is given and no liability whatsoever is assumed by Zetex with respect to the accuracy or use of such information, or infringement of patents or other intellectual property rights arising from such use or otherwise. Zetex does not assume any legal responsibility or will not be held legally liable (whether in contract, tort (including negligence), breach of statutory duty, restriction or otherwise) for any damages, loss of profit, business, contract, opportunity or consequential loss in the use of these circuit applications, under any circumstances.

Life support

Zetex products are specifically not authorized for use as critical components in life support devices or systems without the express written approval of the Chief Executive Officer of Zetex Semiconductors plc. As used herein:

A. Life support devices or systems are devices or systems which:

1. are intended to implant into the body
or
2. support or sustain life and whose failure to perform when properly used in accordance with instructions
for use provided in the labeling can be reasonably expected to result in significant injury to the user.

B. A critical component is any component in a life support device or system whose failure to perform can be reasonably expected to cause the failure of the life support device or to affect its safety or effectiveness.

Reproduction

The product specifications contained in this publication are issued to provide outline information only which (unless agreed by the company in writing) may not be used, applied or reproduced for any purpose or form part of any order or contract or be regarded as a representation relating to the products or services concerned.

Terms and Conditions

All products are sold subjects to Zetex' terms and conditions of sale, and this disclaimer (save in the event of a conflict between the two when the terms of the contract shall prevail) according to region, supplied at the time of order acknowledgement.

For the latest information on technology, delivery terms and conditions and prices, please contact your nearest Zetex sales office.

Quality of product

Zetex is an ISO 9001 and TS16949 certified semiconductor manufacturer.

To ensure quality of service and products we strongly advise the purchase of parts directly from Zetex Semiconductors or one of our regionally authorized distributors. For a complete listing of authorized distributors please visit: www.zetex.com/salesnetwork

Zetex Semiconductors does not warrant or accept any liability whatsoever in respect of any parts purchased through unauthorized sales channels.

ESD (Electrostatic discharge)

Semiconductor devices are susceptible to damage by ESD. Suitable precautions should be taken when handling and transporting devices. The possible damage to devices depends on the circumstances of the handling and transporting, and the nature of the device. The extent of damage can vary from immediate functional or parametric malfunction to degradation of function or performance in use over time. Devices suspected of being affected should be replaced.

Green compliance

Zetex Semiconductors is committed to environmental excellence in all aspects of its operations which includes meeting or exceeding regulatory requirements with respect to the use of hazardous substances. Numerous successful programs have been implemented to reduce the use of hazardous substances and/or emissions.

All Zetex components are compliant with the RoHS directive, and through this it is supporting its customers in their compliance with WEEE and ELV directives.

Product status key:

"Preview"Future device intended for production at some point. Samples may be available

"Active"Product status recommended for new designs

"Last time buy (LTB)"Device will be discontinued and last time buy period and delivery is in effect

"Not recommended for new designs"Device is still in production to support existing designs and production

"Obsolete"Production has been discontinued

Datasheet status key:

"Draft version" This term denotes a very early datasheet version and contains highly provisional information, which may change in any manner without notice.

"Provisional version" This term denotes a pre-release datasheet. It provides a clear indication of anticipated performance. However, changes to the test conditions and specifications may occur, at any time and without notice.

"Issue" This term denotes an issued datasheet containing finalized specifications. However, changes to specifications may occur, at any time and without notice.



ISSUE 4 - JULY 2007

ZXCT1008

PACKAGE OUTLINE

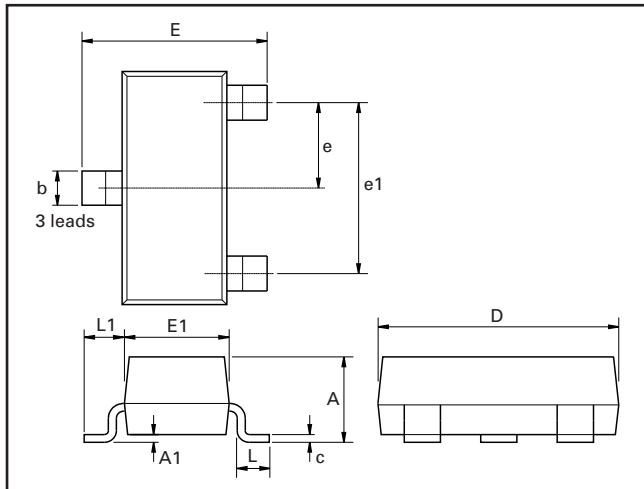

Controlling dimensions are in millimeters. Approximate conversions are given in inches

PACKAGE DIMENSIONS

DIM	Millimeters		Inches		DIM	Millimeters		Inches	
	Min.	Max.	Min.	Max.		Min.	Max.	Max.	Max.
A	—	1.12	—	0.044	e1	1.90 NOM		0.075 NOM	
A1	0.01	0.10	0.0004	0.004	E	2.10	2.64	0.083	0.104
b	0.30	0.50	0.012	0.020	E1	1.20	1.40	0.047	0.055
C	0.085	0.120	0.003	0.008	L	0.25	0.62	0.018	0.024
D	2.80	3.04	0.0110	0.120	L1	0.45	0.62	0.018	0.024
e	0.95 NOM		0.0375 NOM		—	—	—	—	—

© Zetex Semiconductors plc 2007

Europe	Americas	Asia Pacific	Corporate Headquarters
Zetex GmbH Kustermann-Park Balanstraße 59 D-81541 München Germany Telefon: (49) 89 45 49 49 0 Fax: (49) 89 45 49 49 49 europa.sales@zetex.com	Zetex Inc 700 Veterans Memorial Hwy Hauppauge, NY 11788 USA Telephone: (1) 631 360 2222 Fax: (1) 631 360 8222 usa.sales@zetex.com	Zetex (Asia) Ltd 3701-04 Metroplaza Tower 1 Hing Fong Road, Kwai Fong Hong Kong Telephone: (852) 26100 611 Fax: (852) 24250 494 asia.sales@zetex.com	Zetex Semiconductors plc Lansdowne Road, Chadderton Oldham, OL9 9TY United Kingdom Telephone (44) 161 622 4444 Fax: (44) 161 622 4446 hq@zetex.com

These offices are supported by agents and distributors in major countries world-wide.

This publication is issued to provide outline information only which (unless agreed by the Company in writing) may not be used, applied or reproduced for any purpose or form part of any order or contract or be regarded as a representation relating to the products or services concerned. The Company reserves the right to alter without notice the specification, design, price or conditions of supply of any product or service.

For the latest product information, log on to www.zetex.com

ISSUE 4 - JULY 2007