

1A Linear Li+ Battery Chargers with Integrated Pass FET and Thermal Regulation in 2mm x 2mm TDFN

General Description

The MAX8808X/MAX8808Y/MAX8808Z intelligent, stand-alone constant-current/constant-voltage (CCCV), thermally regulated linear chargers are designed for charging a single-cell lithium-ion (Li+) battery. The MAX8808X/MAX8808Y/MAX8808Z integrate the current-sense circuit, MOS pass element, and thermal-regulation circuitry, and eliminate the reverse-blocking Schottky diode to create the simplest and smallest charging solution for handheld equipment.

The MAX8808X functions as a stand-alone charger to control the charging sequence from the prequalification state through fast-charge, top-off charge, and full-charge indication. The MAX8808Y and MAX8808Z eliminate the prequalification state to allow startup into a load without a battery. Proprietary thermal-regulation circuitry limits the die temperature when fast-charging or while exposed to high ambient temperatures, allowing maximum charging current without damaging the IC.

The MAX8808X/MAX8808Y/MAX8808Z achieve high flexibility by providing an adjustable fast-charge current with an external resistor. Other features include a battery charging-status indicator (CHG), an active-low control input (EN) for the MAX8808X and MAX8808Z (active-high control input for the MAX8808Y), and an active-low input power-source detection output ($\overline{\text{ACOK}}$).

The MAX8808X/MAX8808Y/MAX8808Z accept a +4.25V to +15V supply, but disable charging when the input voltage exceeds +7V to protect against unqualified or faulty AC adapters. The MAX8808X/MAX8808Y/MAX8808Z operate over the extended temperature range (-40°C to +85°C) and are available in a compact 8-pin thermally enhanced 2mm x 2mm TDFN package with 0.8mm (max) height.

Applications

Cellular and Cordless Phones
Smartphones and PDAs
Digital Still Cameras and MP3 Players
USB Appliances
Charging Cradles and Docks
Bluetooth® Equipment

Pin Configuration appears at end of data sheet.

Bluetooth is a registered trademark of Bluetooth SIG.

For pricing, delivery, and ordering information, please contact Maxim/Dallas Direct! at 1-888-629-4642, or visit Maxim's website at www.maxim-ic.com.

Features

- ◆ Stand-Alone Linear 1-Cell Li+ Battery Charger
- ◆ No External FET, Reverse Blocking Diode, or Current-Sense Resistor Required
- ◆ Programmable Fast-Charge Current (1A max)
- ◆ Proprietary Die Temperature Regulation Control (+115°C)
- ◆ +4.25V to +15V Input Voltage Range with Input OVP Above +7V
- ◆ Charge-Current Monitor for Fuel Gauging
- ◆ Low Dropout Voltage—300mV at 500mA
- ◆ Input Power-Source Detection Output ($\overline{\text{ACOK}}$) and Charge-Enable Input ($\overline{\text{EN}}$ or EN)
- ◆ Soft-Start Limits Inrush Current
- ◆ Charge-Status Output (CHG) for LED or Microprocessor (μP) Interface
- ◆ Tiny 2mm x 2mm 8-Pin TDFN Package, 0.8mm (max) Height

Ordering Information

PART	PIN-PACKAGE	TOP MARK
MAX8808XETA+	8 TDFN-EP* 2mm x 2mm (T822-1)	AAC
MAX8808YETA+	8 TDFN-EP* 2mm x 2mm (T822-1)	AAB
MAX8808ZETA+	8 TDFN-EP* 2mm x 2mm (T822-1)	AAA

All devices specified over the -40°C to +85°C operating range.
+Denotes lead-free package.

*EP = Exposed paddle.

Typical Operating Circuit

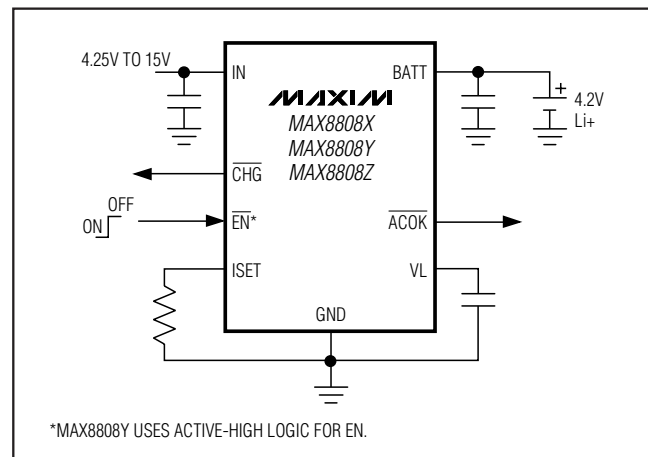

1A Linear Li+ Battery Chargers with Integrated Pass FET and Thermal Regulation in 2mm x 2mm TDFN

ABSOLUTE MAXIMUM RATINGS

IN to GND-0.3V to +16V
 VL, BATT, EN, ACOK, CHG to GND.....-0.3V to +6V
 VL, ISET to GND-0.3V to +4V
 VL to IN.....-16.3V to +0.3V
 IN to BATT Continuous Current.....1.5A
 Continuous Power Dissipation (TA = +70°C)
 8-Pin 2mm x 2mm TDFN (derate 15.4mW/°C
 above +70°C).....1234mW

BATT Short-Circuit Duration.....Continuous
 Operating Temperature Range-40°C to +85°C
 Junction Temperature+150°C
 Storage Temperature Range-65°C to +150°C
 Lead Temperature (soldering, 10s).....+300°C

Stresses beyond those listed under "Absolute Maximum Ratings" may cause permanent damage to the device. These are stress ratings only, and functional operation of the device at these or any other conditions beyond those indicated in the operational sections of the specifications is not implied. Exposure to absolute maximum rating conditions for extended periods may affect device reliability.

ELECTRICAL CHARACTERISTICS

(VIN = 5V, VBATT = 4.0V, RACOK = RCHG = 100kΩ to 5V, EN = unconnected (for the MAX8808X and MAX8808Z), EN = VL (for the MAX8808Y), Riset = 2.8kΩ to GND, CVL = 0.47μF, CBATT = 1μF, TA = -40°C to +85°C, unless otherwise noted. Typical values are at TA = +25°C.) (Note 1)

PARAMETER	CONDITIONS		MIN	TYP	MAX	UNITS
Input Voltage Range			0		15	V
Input Operating Range			4.25		6.50	V
ACOK Threshold	VIN - VBATT, 10mV hysteresis (typ)	VIN rising	15	40	60	mV
		VIN falling	10	30	45	
Overvoltage-Lockout Trip Point	VIN rising, 100mV hysteresis (typ)		6.5	7	7.5	V
IN Input Current	Charging (IIN - IBATT)			0.8	2	mA
	Disabled			0.23	0.50	
	OFF state (VIN = VBATT = 4.0V)				0.065	
VL Output Voltage	IVL = 100μA			3.0		V
VL Load Regulation	IVL = 100μA to 2mA			-5	-30	mV
VL Undervoltage-Lockout Trip Point	VVL rising, 100mV hysteresis (typ)			2.74		V
BATT Input Current	VIN = 0 to 4V			1	10	μA
	Disabled			1	10	
Maximum RMS Charge Current			1			ARMS
Battery Regulation Voltage	IBATT = 1mA		4.162	4.200	4.238	V
Minimum BATT Bypass Capacitance				2.2		μF/A
Fast-Charge Current Loop System Accuracy	VBATT = 3.5V	TA = 0°C to +85°C	418	465	512	mA

1A Linear Li+ Battery Chargers with Integrated Pass FET and Thermal Regulation in 2mm x 2mm TDFN

ELECTRICAL CHARACTERISTICS (continued)

($V_{IN} = 5V$, $V_{BATT} = 4.0V$, $R_{ACOK} = R_{CHG} = 100k\Omega$ to 5V, \overline{EN} = unconnected (for the MAX8808X and MAX8808Z), $EN = VL$ (for the MAX8808Y), $R_{ISET} = 2.8k\Omega$ to GND, $C_{VL} = 0.47\mu F$, $C_{BATT} = 1\mu F$, $T_A = -40^\circ C$ to $+85^\circ C$, unless otherwise noted. Typical values are at $T_A = +25^\circ C$.) (Note 1)

PARAMETER	CONDITIONS		MIN	TYP	MAX	UNITS
Prequal Charge Current	Percentage of the fast-charge current, $V_{BATT} = 2.2V$, MAX8808X		5	10	15	%
Die Temperature Regulation Threshold				+115		$^\circ C$
V_{BATT} Prequal Threshold Voltage	V_{BATT} rising, MAX8808X		2.3	2.5	2.7	V
Current-Sense Amplifier Gain, I_{BATT} to I_{SET}	$I_{BATT} = 500mA$, $V_{ISET} = 1.4V$	$T_A = 0^\circ C$ to $+85^\circ C$	0.97	1.08	1.19	mA/A
Regulator Dropout Voltage ($V_{IN} - V_{BATT}$)	$V_{BATT} = 4.1V$, $I_{BATT} = 425mA$			250	430	mV
EN/\overline{EN} Logic Input Low Voltage	$4.25V < V_{IN} < 6.5V$				0.52	V
EN/\overline{EN} Logic Input High Voltage	$4.25V < V_{IN} < 6.5V$		1.3			V
\overline{EN} Internal Pulldown Resistor	MAX8808X and MAX8808Z only		100	200	400	k Ω
EN Input Leakage Current	MAX8808Y, $V_{EN} = 5.5V$	$T_A = +25^\circ C$			1	μA
		$T_A = +85^\circ C$			0.002	
\overline{CHG} Output Low Voltage	$I_{\overline{CHG}} = 5mA$				0.4	V
\overline{CHG} Output High Leakage Current	$V_{\overline{CHG}} = 5.5V$	$T_A = +25^\circ C$			1	μA
		$T_A = +85^\circ C$			0.002	
\overline{ACOK} Output Low Voltage	$I_{\overline{ACOK}} = 5mA$				0.4	V
\overline{ACOK} Output High Leakage Current	$V_{\overline{ACOK}} = 5.5V$	$T_A = +25^\circ C$			1	μA
		$T_A = +85^\circ C$			0.002	
Full-Battery Detection Current Threshold	I_{BATT} falling, percentage of the fast-charge current		5	10	15	%

Note 1: Specifications are 100% production tested at $T_A = +25^\circ C$. Limits over the operating temperature range are guaranteed by design and characterization.

MAX8808X/MAX8808Y/MAX8808Z

1A Linear Li+ Battery Chargers with Integrated Pass FET and Thermal Regulation in 2mm x 2mm TDFN

Typical Operating Characteristics

($V_{IN} = 5V$, $V_{BATT} = 4.0V$, $\overline{ACOK} = \overline{EN} =$ unconnected, $R_{ISET} = 2.8k\Omega$ to GND, $C_{IN} = 1\mu F$, $C_{BATT} = 1\mu F$, $C_{VL} = 0.47\mu F$, $T_A = +25^\circ C$, unless otherwise noted.)

SUPPLY CURRENT vs. INPUT VOLTAGE

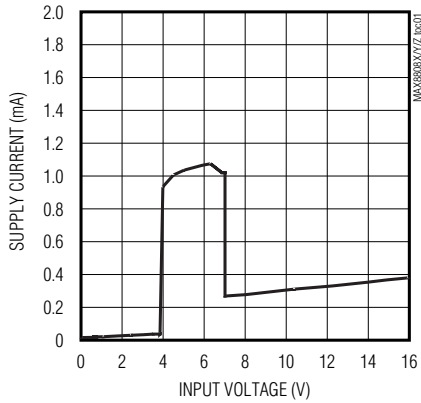

DISABLED-MODE SUPPLY CURRENT vs. INPUT VOLTAGE

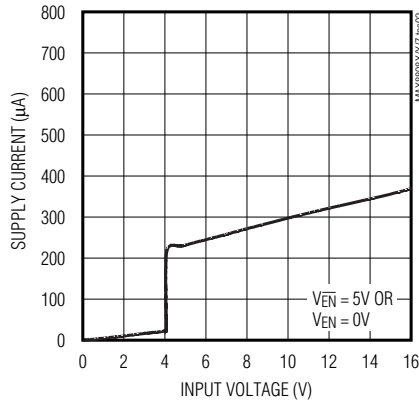

CHARGE CURRENT vs. BATTERY VOLTAGE

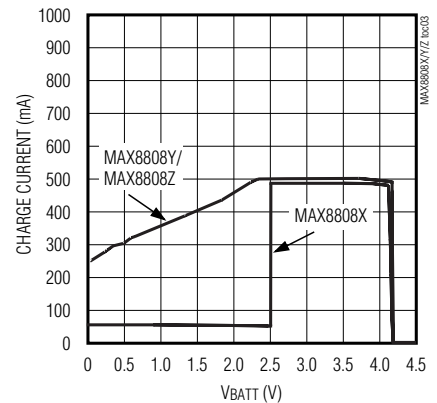

CHARGE CURRENT vs. INPUT VOLTAGE

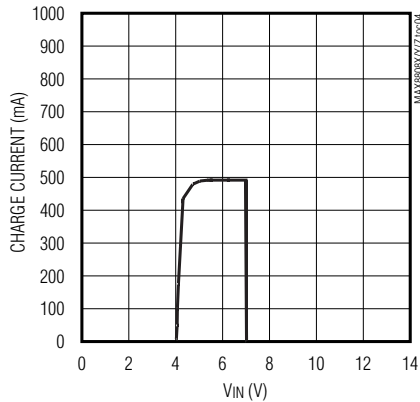

CHARGE CURRENT vs. INPUT VOLTAGE HEADROOM

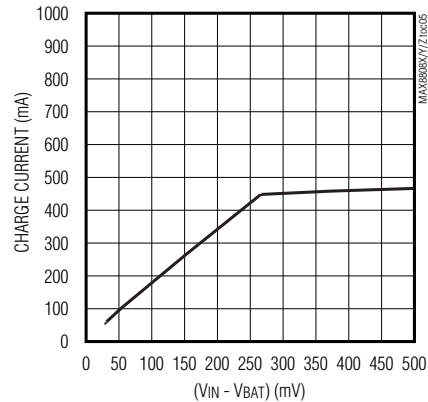

BATTERY REGULATION VOLTAGE vs. AMBIENT TEMPERATURE

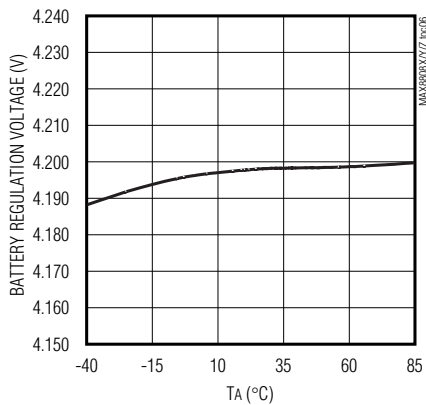

CHARGE CURRENT vs. AMBIENT TEMPERATURE

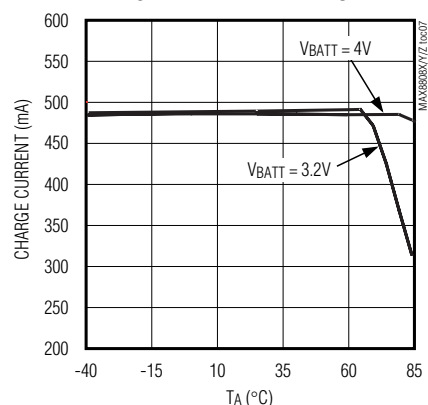

1A Linear Li+ Battery Chargers with Integrated Pass FET and Thermal Regulation in 2mm x 2mm TDFN

Pin Description

PIN	NAME	FUNCTION
1	IN	Input Supply Voltage. Bypass IN to GND with a 1µF or larger ceramic capacitor to improve line noise and input transient rejection.
2	VL	Internally Generated Logic Supply for IC. Bypass VL to GND with a 0.47µF ceramic capacitor.
3	GND	Ground. Connect GND and exposed pad to a large copper ground plane for maximum power dissipation. Connect GND to the exposed paddle directly under the IC.
4	ISET	Charge-Current Program and Fast-Charge Current Monitor. Output current from ISET is 1.08mA per amp of battery charging current. Set the charging current by connecting a resistor from ISET to GND. Fast-charge current = $1302V / R_{ISET}\Omega$.
5	$\overline{\text{CHG}}$	Charging Indicator. $\overline{\text{CHG}}$ is an open-drain output that goes low (LED capable) when charging begins. $\overline{\text{CHG}}$ is high impedance when the battery current drops below 10% of the fast-charging current, or when the IC is disabled. Connect a pullup resistor to the µP's I/O voltage when interfacing with a µP logic input.
6	$\overline{\text{EN}}$ (MAX8808X/ MAX8808Z)	Logic-Level Enable Input. Drive $\overline{\text{EN}}$ high to disable charger. Pull $\overline{\text{EN}}$ low or leave unconnected for normal operation. $\overline{\text{EN}}$ has an internal 200kΩ pulldown resistor.
	EN (MAX8808Y)	Logic-Level Enable Input. Drive EN low to disable charger. Pull EN high for normal operation. EN has no internal pullup or pulldown resistor.
7	$\overline{\text{ACOK}}$	Input Status Indicator. $\overline{\text{ACOK}}$ is an open-drain output that asserts low when $V_{IN} < +7V$ and $(V_{IN} - V_{BATT}) \geq 40mV$. $\overline{\text{ACOK}}$ requires an external 100kΩ pullup resistor. $\overline{\text{ACOK}}$ is high impedance during shutdown.
8	BATT	Li+ Battery Connection. Bypass BATT to GND with a ceramic capacitor of at least 2.2µF per ampere of charge current.
—	EP	Exposed Paddle. Connect the exposed paddle to a large ground plane for maximum power dissipation. Connect GND to the exposed paddle directly under the IC.

MAX8808X/MAX8808Y/MAX8808Z

1A Linear Li+ Battery Chargers with Integrated Pass FET and Thermal Regulation in 2mm x 2mm TDFN

Detailed Description

The MAX8808X/MAX8808Y/MAX8808Z chargers use voltage, current, and thermal-control loops to charge a single Li+ cell and protect the battery (Figure 1). When a Li+ battery with a cell voltage below 2.5V is inserted, the MAX8808X charger enters the prequalification stage where it precharges that cell with 10% of the user-programmed fast-charge current (Figure 2). The CHG indicator output is driven low to indicate entry into the prequalification state. When battery voltage

exceeds 2.5V, the charger soft-starts as it enters the fast-charge stage. In the MAX8808X/MAX8808Y/MAX8808Z, the fast-charge current level is programmed through a resistor from ISET to GND. As the battery voltage approaches 4.2V, the charging current is reduced. If the battery current drops to less than 10% of the fast-charging current, the CHG indicator goes high impedance, signaling that the battery is fully charged. The ICs then enter a constant voltage-regulation mode to maintain the battery at full charge.

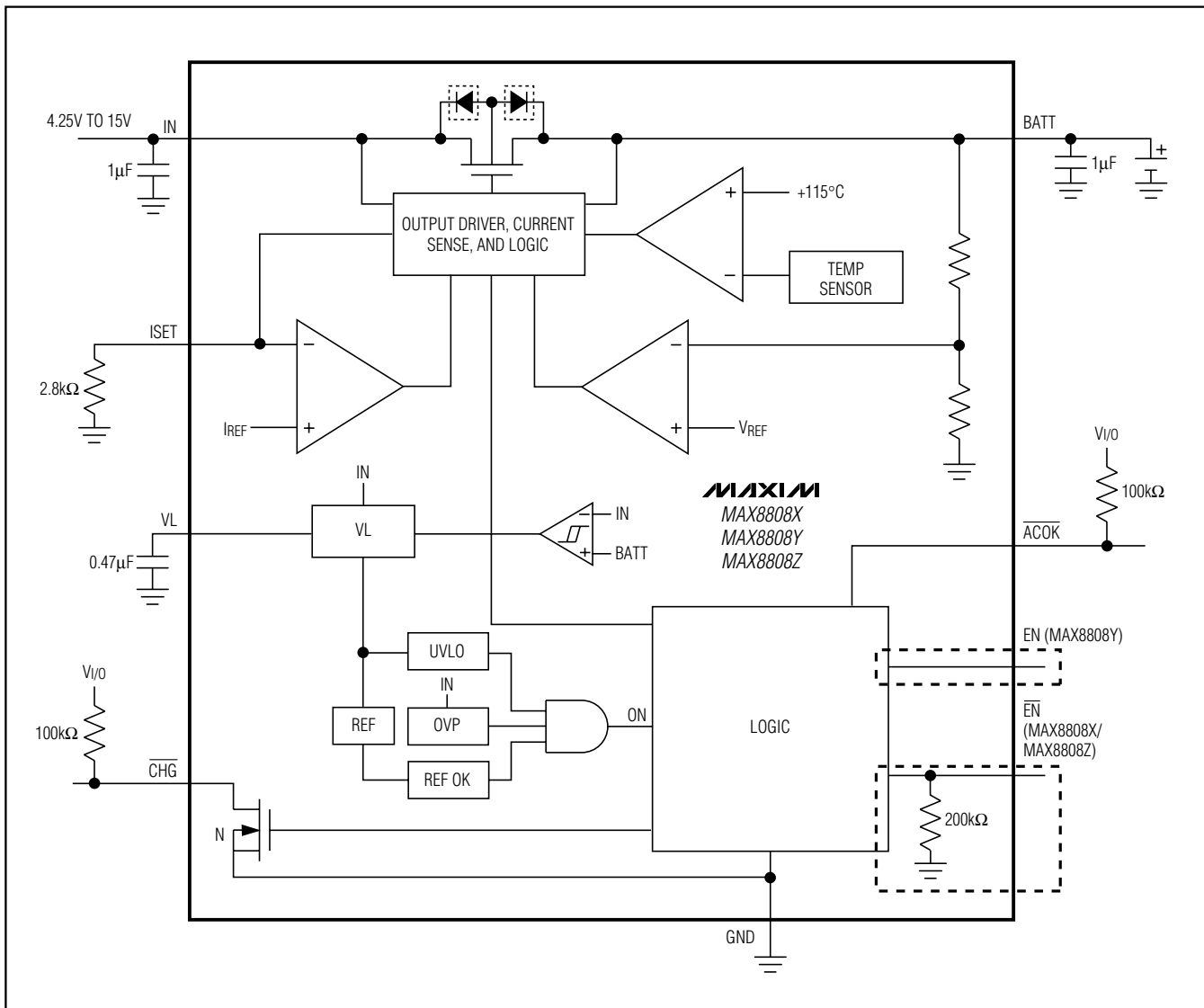

Figure 1. Functional Diagram

1A Linear Li+ Battery Chargers with Integrated Pass FET and Thermal Regulation in 2mm x 2mm TDFN

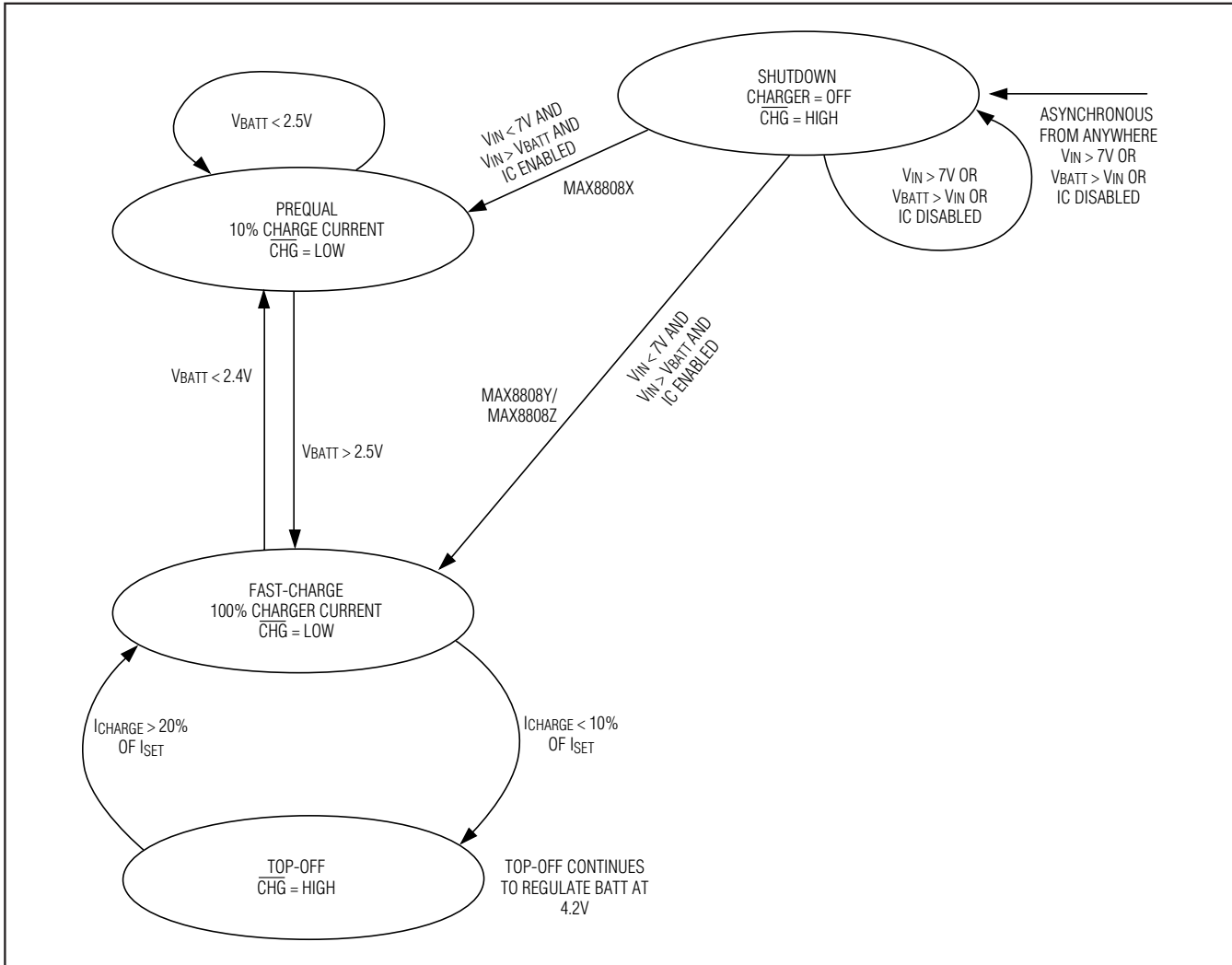

Figure 2. Charge-State Diagram

Thermal Regulation

The thermal-regulation loop limits the MAX8808X/MAX8808Y/MAX8808Z die temperature to +115°C by reducing the charge current as necessary. This feature not only protects the ICs from overheating, but also allows a higher charge current without risking damage to the system.

\overline{EN} (MAX8808X/MAX8808Z) and EN (MAX8808Y) Charger Enable Input

The MAX8808X/MAX8808Z contain an active-low logic input (\overline{EN}) used to enable the charger. Drive \overline{EN} low, leave floating, or connect to GND to enable the charge-control circuitry. Drive \overline{EN} high to disable the

charger-control circuitry. \overline{EN} has a 200k Ω internal pull-down resistor.

The MAX8808Y contains an active-high enable input (EN) to enable the charger. Drive EN high to enable the charge-control circuitry. Drive EN low to disable the charger-control circuitry. Do not leave EN floating. It has no internal pullup or pull-down resistor.

\overline{ACOK} Output

The open-drain \overline{ACOK} output asserts low when $+4.25V \leq V_{IN} \leq +7V$ and $V_{IN} - V_{BATT} \geq 40mV$. \overline{ACOK} requires an external pullup resistor (100k Ω typ). \overline{ACOK} is high impedance during shutdown.

1A Linear Li+ Battery Chargers with Integrated Pass FET and Thermal Regulation in 2mm x 2mm TDFN

VL Internal Voltage Regulator

The MAX8808X/MAX8808Y/MAX8808Z linear chargers contain an internal linear regulator to supply the power for the IC. Bypass VL to GND with a 0.47µF ceramic capacitor. VL is regulated to 3.0V whenever the input voltage is above the battery voltage.

CHG Charge-Indicator Output

CHG is an open-drain output that indicates charge status. Table 1 describes the state of CHG during different stages of operation. CHG is suitable for driving a charge-indication LED. If the MAX8808X/MAX8808Y/MAX8808Z is used in conjunction with a µP, a pullup resistor to the logic I/O voltage allows CHG to indicate charge status to the µP instead of driving an LED.

Soft-Start

The soft-start algorithm activates when entering fast-charge mode. In the MAX8808X, when the prequalification state is complete (VBATT exceeds +2.5V), the charging current ramps up in 1ms to the full charging current. This reduces the inrush current on the input supply. Note that the MAX8808Y and MAX8808Z do not have a prequalification state and enter soft-start directly after being enabled.

Applications Information

Charge-Current Selection

The maximum charging current is programmed by an external resistor connected from ISET to GND (RISET).

Calculate RISET as follows:

$$R_{ISET} = 1302V / I_{FASTCHG}$$

where IFASTCHG is in Amps and RISET is in Ohms. ISET can be used to monitor the fast-charge current level. The output current from ISET is 1.08mA per amp of charging current. The output voltage at ISET is proportional to the charging current:

$$V_{ISET} = (I_{CHARGE} \times R_{ISET}) / 930$$

The voltage at ISET is nominally 1.4V at the selected fast-charge current, and falls with charging current as the cell becomes fully charged or as the thermal-regulation circuitry activates.

Capacitor Selection

Connect a ceramic capacitor from BATT to GND for proper stability. Use a 1µF X5R ceramic capacitor for most applications. Connect a 1µF ceramic capacitor from IN to GND. Use a larger input bypass capacitor for high charging currents to reduce supply noise. Connect a 0.47µF ceramic capacitor from VL to GND.

Thermal Considerations

The MAX8808X/MAX8808Y/MAX8808Z are available in a thermally enhanced TDFN package with exposed paddle. Connect the exposed paddle to a large copper ground plane to provide a thermal contact between the device and the circuit board for increased power dissipation. The exposed paddle transfers heat away from the device, allowing the ICs to charge the battery with maximum current, while minimizing the increase in die temperature.

Table 1. CHG States

EN MAX8808X	EN MAX8808Y	EN MAX8808Z	VIN	VBATT	IBATT	CHG	STATE
X	X	X	≤VBATT	≥VIN	0	High-Impedance	Shutdown
Low	—	—	4.25V ≤ VIN ≤ 7V	<2.4V	10% of IFAST	Low	Prequal
Low	High	Low	4.25V ≤ VIN ≤ 7V	≥2.5V	IFAST*	Low	Fast-Charge
Low	High	Low	4.25V ≤ VIN ≤ 7V	4.2V	<10% of IFAST	High-Impedance	Top-off
Low	High	Low	>7V	X	0	High-Impedance	Shutdown
High	Low	High	X	X	0	High-Impedance	Disabled

X = Don't care.

— = Prequal not applicable to MAX8808Y and MAX8808Z.

*IFAST is reduced as necessary to prevent the die temperature from exceeding +115°C.

1A Linear Li+ Battery Chargers with Integrated Pass FET and Thermal Regulation in 2mm x 2mm TDFN

DC Input Sources

The MAX8808X/MAX8808Y/MAX8808Z operate from well-regulated DC sources. The full charging input voltage range is 4.25V to 7V. The device can withstand up to 15V on the input without damage to the IC. If V_{IN} is

greater than 7V, the internal overvoltage-protection circuitry disables charging until the input falls below 7V. An appropriate power supply must provide at least 4.25V at the desired peak charging current. It also must stay below 6.5V when unloaded.

Application Circuits

Stand-Alone Li+ Charger

The MAX8808X/MAX8808Y/MAX8808Z provide a complete Li+ charging solution. Figure 3 shows a stand-alone Li+ battery charger. The 2.8k Ω resistor connected to ISET sets a charging current of 465mA. The LED connected to the CHG output indicates when either fast-charge or precharge qualification has begun. When the battery is full, CHG turns high impedance and the LED turns off.

Microprocessor-Interfaced Charger

Figure 4 shows the MAX8808X as a μ P co-operated Li+ battery charger. The MAX8808X begins charging the battery when \overline{EN} is low. The μ P can drive \overline{EN} high to disable the charger. The MAX8808X generates a \overline{ACOK} signal to indicate the presence of an input supply. CHG is used to detect the charge status of the battery. By monitoring V_{ISET} , the system can measure the charging current.

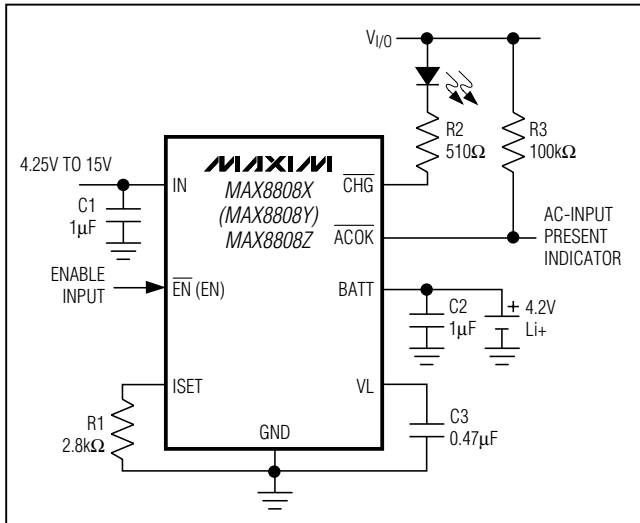

Figure 3. Stand-Alone Li+ Battery Charger

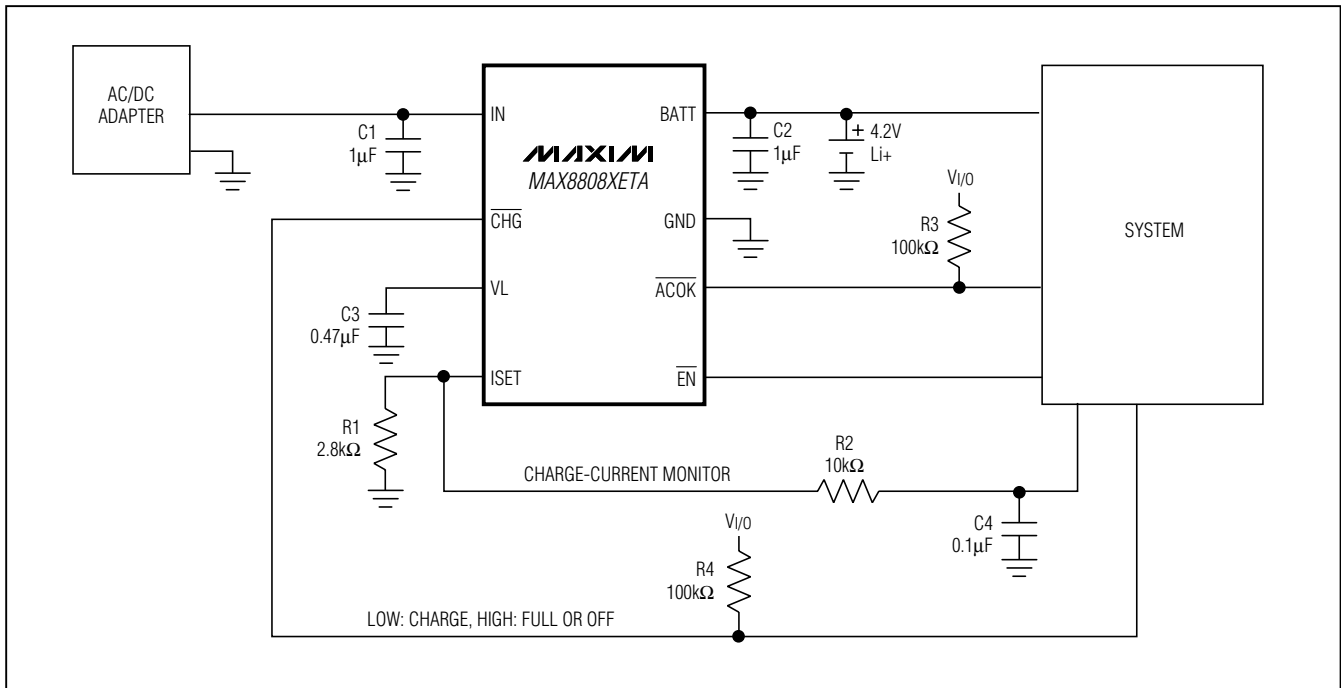

Figure 4. μ P-Interfaced Li+ Battery Charger

1A Linear Li+ Battery Chargers with Integrated Pass FET and Thermal Regulation in 2mm x 2mm TDFN

USB-Powered Li+ Charger

The universal serial bus (USB) provides a high-speed serial communication port as well as power for the remote device. The MAX8808X/MAX8808Y/MAX8808Z can be configured to charge a battery at the highest current possible from the host port. Figure 5 shows the MAX8808X as a USB battery charger. To make the circuit compatible with either 100mA or 500mA USB ports, the circuit initializes at 100mA charging current. The μ P then enumerates the host to determine its current capability. If the host port is capable, the charging current is increased to 425mA to avoid exceeding the 500mA USB specification.

Layout and Bypassing

Place the input capacitor as close to the device as possible. Provide a large copper ground plane to allow the exposed paddle to sink heat away from the device. Connect the battery to BATT as close to the device as possible to provide accurate battery voltage sensing. Make all high-current traces short and wide to minimize voltage drops. A sample layout is available in the MAX8808 evaluation kit to speed designs.

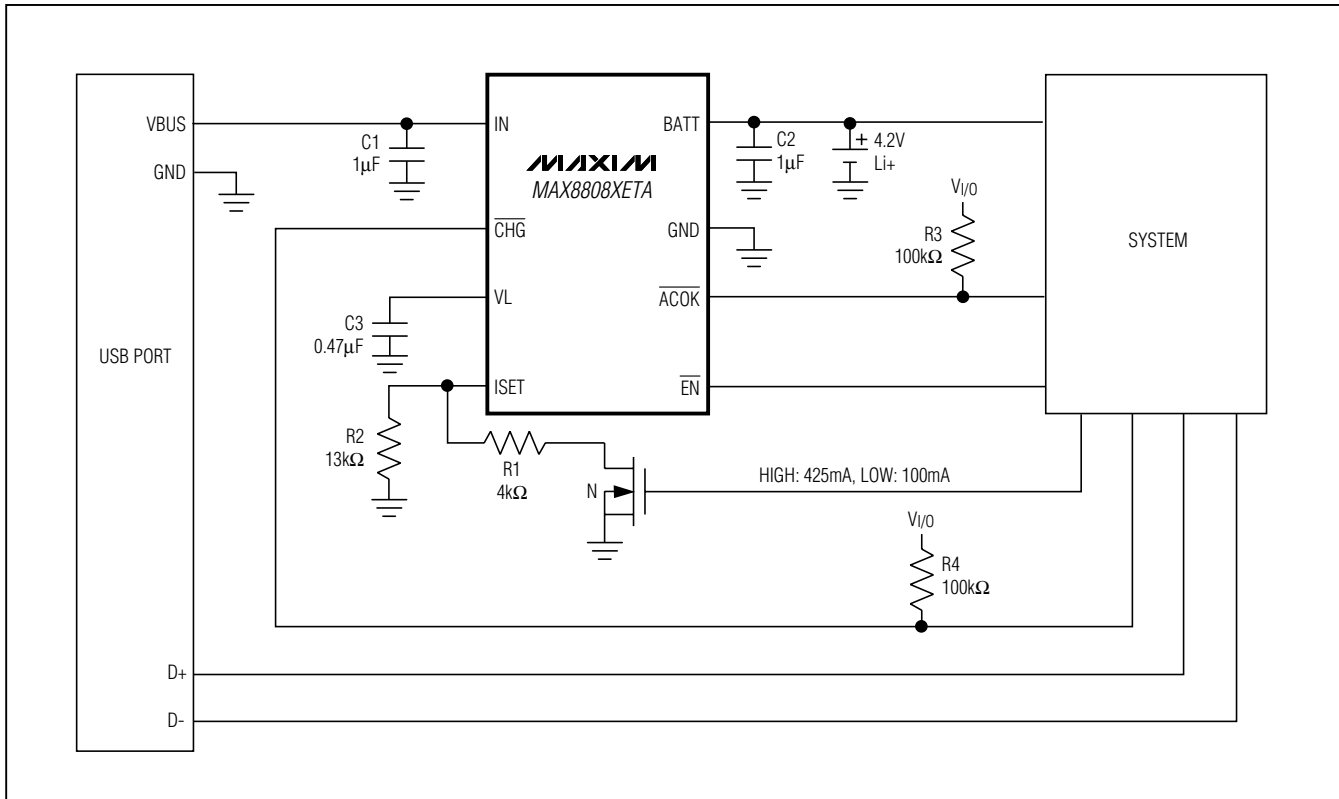
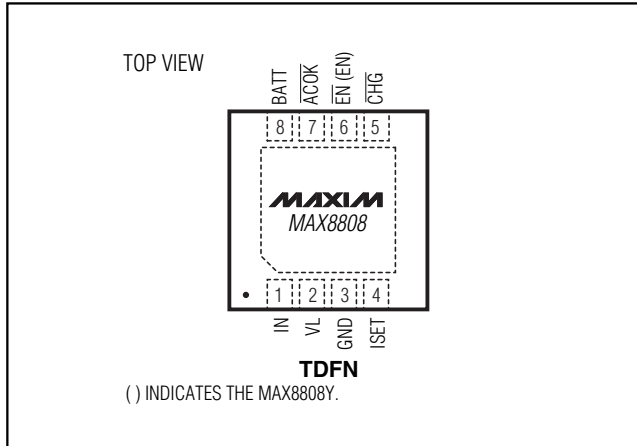

Figure 5. USB Battery Charger

1A Linear Li+ Battery Chargers with Integrated Pass FET and Thermal Regulation in 2mm x 2mm TDFN

Pin Configuration



Chip Information

PROCESS: BiCMOS

MAX8808X/MAX8808Y/MAX8808Z

1A Linear Li+ Battery Chargers with Integrated Pass FET and Thermal Regulation in 2mm x 2mm TDFN

Package Information

(The package drawing(s) in this data sheet may not reflect the most current specifications. For the latest package outline information go to www.maxim-ic.com/packages.)

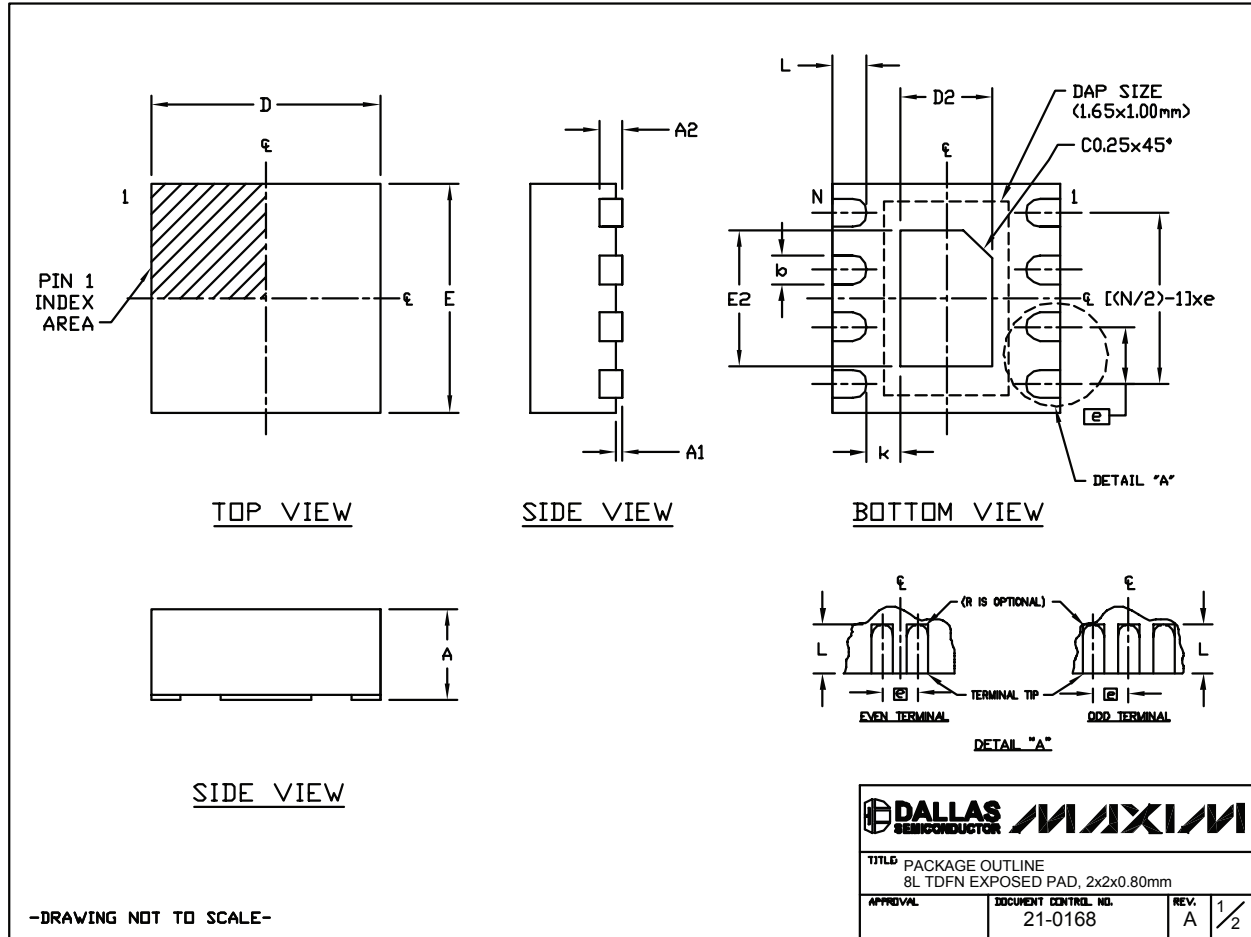

1A Linear Li+ Battery Chargers with Integrated Pass FET and Thermal Regulation in 2mm x 2mm TDFN

Package Information (continued)

(The package drawing(s) in this data sheet may not reflect the most current specifications. For the latest package outline information go to www.maxim-ic.com/packages.)

MAX8808X/MAX8808Y/MAX8808Z

COMMON DIMENSIONS		
SYMBOL	MIN.	MAX.
A	0.70	0.80
D	1.90	2.10
E	1.90	2.10
A1	0.00	0.05
L	0.20	0.40
k	0.25 MIN.	
A2	0.20 REF.	

PACKAGE VARIATIONS								
PKG. CODE	N	D2	E2	e	JEDEC SPEC	b	[(N/2)-1] x e	DOWNBONDS ALLOWED
T822-1	8	0.70±0.10	1.30±0.10	0.50 TYP.	MO229	0.25±0.05	1.50 REF	NO

NOTES:

1. ALL DIMENSIONS ARE IN mm. ANGLES IN DEGREES.
2. COPLANARITY APPLIES TO THE EXPOSED PAD AS WELL AS THE TERMINALS. COPLANARITY SHALL NOT EXCEED 0.08 mm.
3. WARPAGE SHALL NOT EXCEED 0.08 mm.
4. PACKAGE LENGTH/PACKAGE WIDTH ARE CONSIDERED AS SPECIAL CHARACTERISTIC(S).
5. COMPLY TO JEDEC MO229 EXCEPT D2 AND E2 DIMENSIONS.
6. "N" IS THE TOTAL NUMBER OF LEADS.
7. NUMBER OF LEADS SHOWN ARE FOR REFERENCE ONLY.

-DRAWING NOT TO SCALE-

			
TITLE PACKAGE OUTLINE 8L TDFN EXPOSED PAD, 2x2x0.80mm			
APPROVAL	DOCUMENT CONTROL NO. 21-0168	REV. A	2/2

Maxim cannot assume responsibility for use of any circuitry other than circuitry entirely embodied in a Maxim product. No circuit patent licenses are implied. Maxim reserves the right to change the circuitry and specifications without notice at any time.

Maxim Integrated Products, 120 San Gabriel Drive, Sunnyvale, CA 94086 408-737-7600 _____ 13