

# FAN3988

## USB/Charger and Over-Voltage Detection Device

### Features

- Charger/USB Detection Device
- Charger/USB Device Detection Flag
- Over-/Under-Voltage Detection Flag
- $V_{BUS}$  Supply: 2.7V to 20V
- $C_{ON}$  of 1.5pF
- 6-Lead MicroPak™ MLP Package

### Applications

- Mobile Phones
- Handheld Devices

### Description

The FAN3988 is a USB-connection-monitoring device used to determine if a standard USB device or a battery-charging device is connected.

The FAN3988 sets the FLAG1 pin to logic HIGH or LOW as an indicator to the system controller that a standard USB device or a charger is connected to the USB port. The FAN3988 also monitors the  $V_{BUS}$  for over- or under-voltage conditions. The FLAG2 pin is set LOW if  $V_{BUS}$  is less than 3.3V or greater than 6.0V.

The FAN3988 is packaged in a very small 6-lead MicroPak™ MLP package suitable for small board space applications, such as mobile phones.

### Ordering Information

Part Number	Operating Temperature Range	Package	Packing Method	Quantity
FAN3988IL6X_F113	-40°C to +85°C	6-Lead MicroPak™ MLP Package	Reel	3000

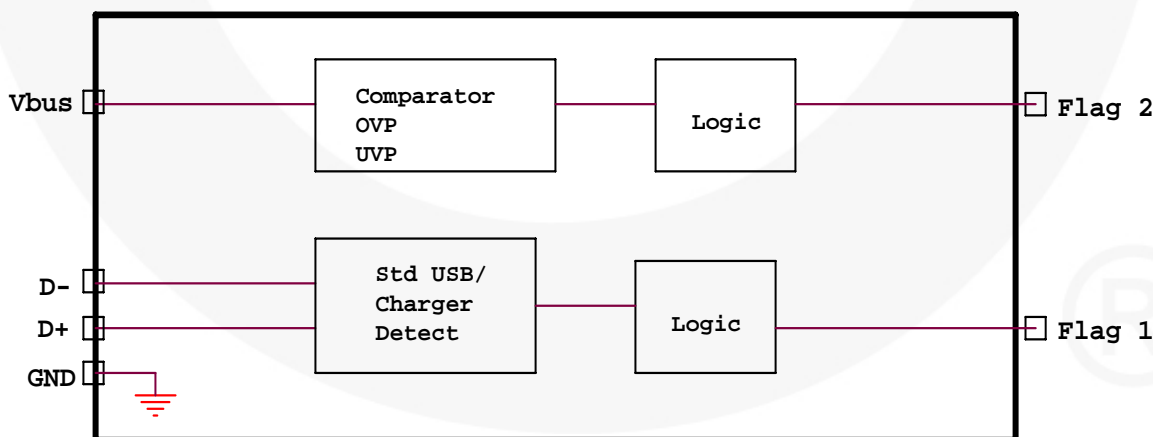

Figure 1. Block Diagram

## Pin Configuration

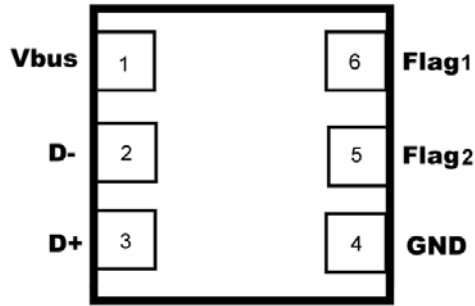

Figure 2. Pin Configuration (Top View)

## Pin Definitions

Pin#	Name	Type	Description
1	Vbus	Input	Power input from charger, USB device, or handheld battery
2	D-	Input	USB data input
3	D+	Input	USB data input
4	Gnd	Input	Device ground
5	Flag2	Output	Over/under-voltage flag output
6	Flag1	Output	Charger/standard USB device detect flag

## Truth Table

Connection State	V <sub>BUS</sub>	D-	D+	FLAG1	FLAG2
STD USB Device	0V	15K to GND <sup>(1)</sup>	1.5K to V <sub>DD</sub> <sup>(1)</sup>	LOW	LOW
USB Charger	5V	Short to D+	Short to D-	HIGH	HIGH
V <sub>BUS</sub> GT 6V	GT 6V	Short to D+	Short to D-	HIGH	LOW
V <sub>BUS</sub> LT 3.3V	LT 3.3V	Short to D+	Short to D-	HIGH	LOW
PC Data/Charger	5V	Open	Open	LOW	HIGH

**Note:**

1. See Figure 7.

## Absolute Maximum Ratings

Stresses exceeding the absolute maximum ratings may damage the device. The device may not function or be operable above the recommended operating conditions and stressing the parts to these levels is not recommended. In addition, extended exposure to stresses above the recommended operating conditions may affect device reliability. The absolute maximum ratings are stress ratings only.

Symbol	Parameter	Min.	Max.	Unit
V <sub>BUS</sub>	DC Supply Voltage	-0.3	20.0	V

## Reliability Information

Symbol	Parameter	Min.	Typ.	Max.	Unit
T <sub>J</sub>	Junction Temperature			+150	°C
T <sub>STG</sub>	Storage Temperature Range	-65		+150	°C
Θ <sub>JA</sub>	Thermal Resistance, JEDEC Standard, Multi-layer Test Boards, Still Air		41		°C/W

## ESD Information

Symbol	Parameter		Max.	Unit
ESD	Electrostatic Discharge Information	Human Body Model, JESD22-A114	5	kV
		Charged Device Model, JESD22-C101	2	

## Recommended Operating Conditions

The Recommended Operating Conditions table defines the conditions for actual device operation. Recommended operating conditions are specified to ensure optimal performance to the datasheet specifications. Fairchild does not recommend exceeding them or designing to Absolute Maximum Ratings.

Symbol	Parameter	Min.	Typ.	Max.	Unit
T <sub>A</sub>	Operating Temperature Range	-40		+85	°C
V <sub>BUS</sub>	Supply Voltage Range	2.7	5.0	20.0	V

## DC Electrical Characteristics

$T_A = 25^\circ\text{C}$ ,  $V_{\text{BUS}} = 5.0\text{V}$ , unless otherwise noted.

Symbol	Parameter	Conditions	Min.	Typ.	Max.	Units
<b>Supply</b>						
$V_{\text{BUS}}$	Supply Voltage Range	$V_{\text{BUS}}$ Range	2.7	5.0	20.0	V
$I_{\text{BUS}}$	Quiescent Supply Current	$V_{\text{BUS}} = +5.0\text{V}$ , D+ D- Shorted		1.2	2.0	mA
$t_{\text{SUPPLY}}$	Power-Up Stabilization Time	$V_{\text{BUS}} = +5.0\text{V}$ , D+ D- Shorted		10		ms
<b>Input Characteristics</b>						
$C_{\text{D+}}$	Input Capacitance			1.5	2.0	pF
$C_{\text{D-}}$	Input Capacitance			1.5	2.0	pF
$I_{\text{off D+}}$	Off Leakage Current	$V_{\text{BUS}} = 0\text{V}$ or $5\text{V}$ $V_{\text{IN}}$ on D+ = $5\text{V}$		1		$\mu\text{A}$
$I_{\text{off D-}}$	Off Leakage Current	$V_{\text{BUS}} = 0\text{V}$ or $5\text{V}$ $V_{\text{IN}}$ on D- = $5\text{V}$		1		$\mu\text{A}$
<b>Output Characteristics</b>						
$\text{OV}_{\text{DETECT}}$	Over-Voltage Threshold Detect	$V_{\text{BUS}} = +5.0\text{V}$ , Flag2 = LOW	5.8	6.0	6.5	V
$\text{OV}_{\text{HYST}}$	Over-Voltage Hysteresis	Voltage Sweep through Upper and Lower Trip Points		100		mV
$\text{UV}_{\text{DETECT}}$	Under-Voltage Threshold Detect	$V_{\text{BUS}} = +5.0\text{V}$ , Flag2 = LOW	3.0	3.3	3.6	V
$\text{UV}_{\text{HYST}}$	Under-Voltage Hysteresis	Voltage Sweep through Upper and Lower Trip Points		100		mV
$V_{\text{OH FLAG1/FLAG2}}$	Minimum HIGH Output Voltage	$V_{\text{BUS}} = +5.0\text{V}$ , $I_{\text{OH}} = -20\mu\text{A}$	2.4			V
$V_{\text{OL FLAG1/FLAG2}}$	Maximum LOW Output Voltage	$V_{\text{BUS}} = +5.0\text{V}$ , $I_{\text{OL}} = 20\mu\text{A}$			0.3	V
$t_{\text{off}}$	Flag2 HIGH to LOW	100pF Load		10		ns
$t_{\text{on}}$	Flag2 LOW to HIGH	100pF Load		44		ns

## Typical Performance Characteristics

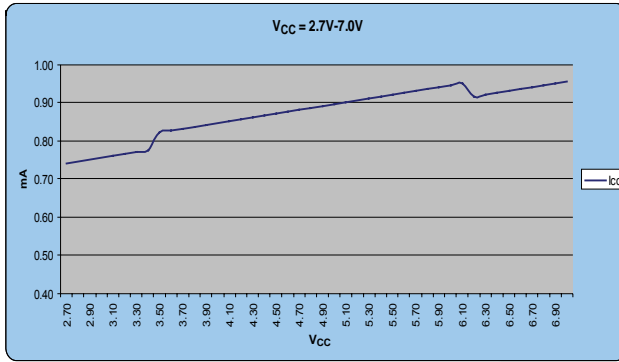

Figure 3. I<sub>Bus</sub> vs. V<sub>Bus</sub> (2.7V-7.0V) No Load

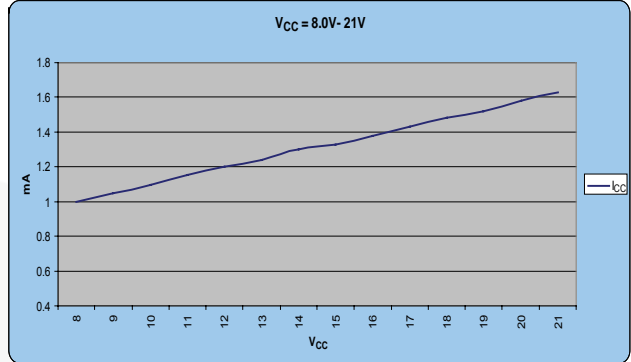

Figure 4. I<sub>Bus</sub> vs. V<sub>Bus</sub> (8.0V-21V) No Load

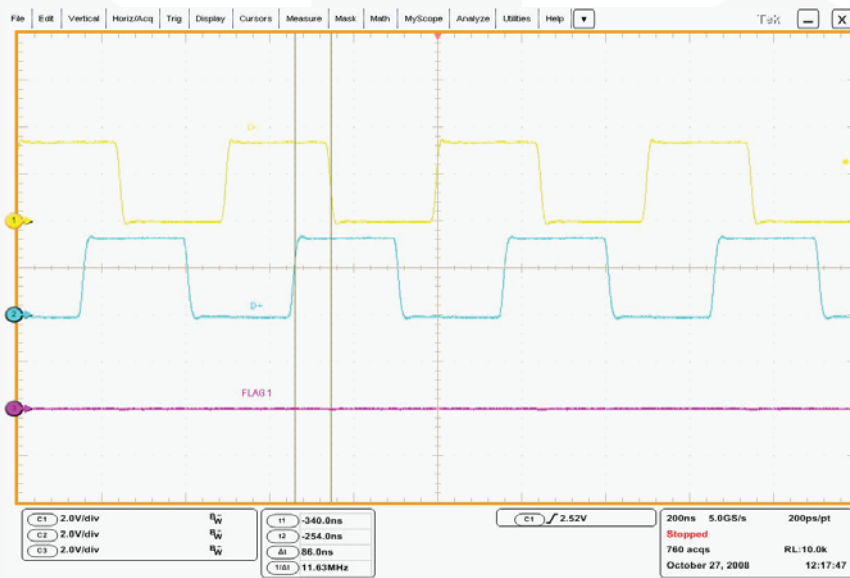

Figure 5. No Fault on Flag 1, Skew=65ns

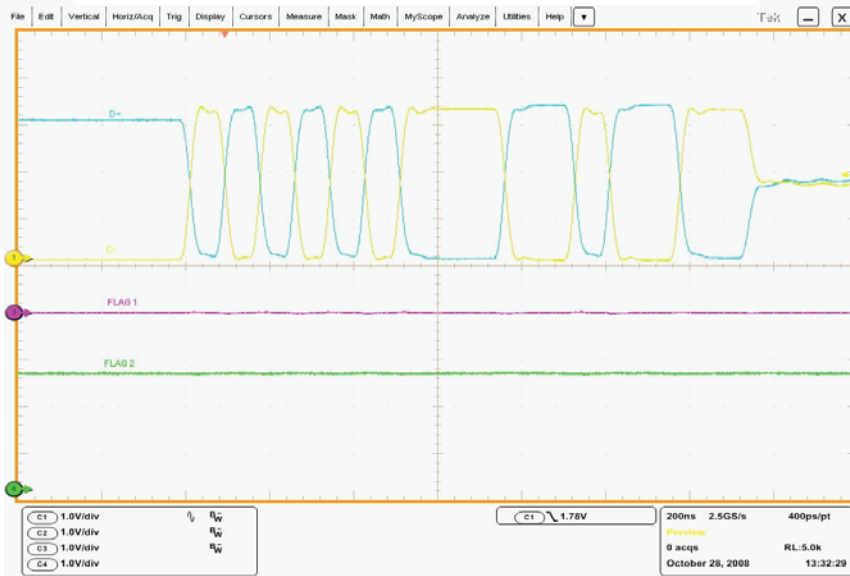

Figure 6. PC Data Running D+/D- (Flag 1 and Flag 2 at Correct Levels)

## Application Information

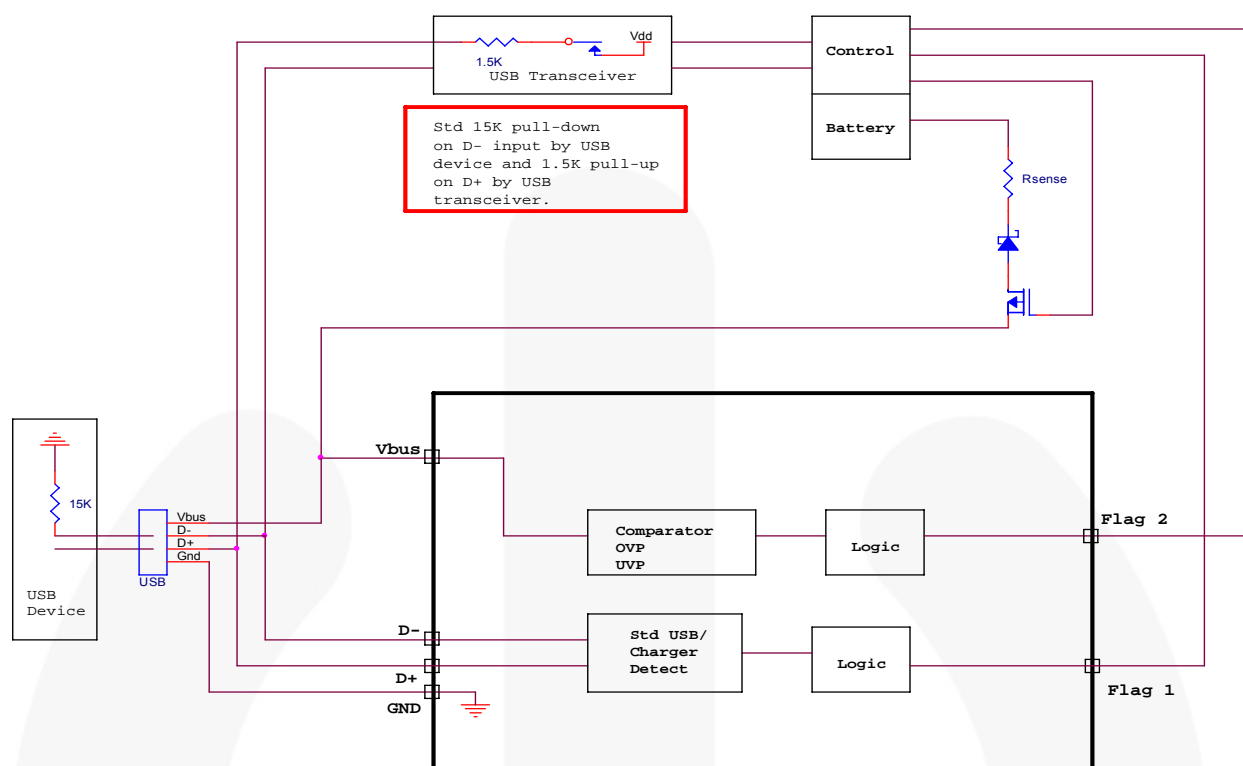

Figure 7. Typical Application System with USB Transceiver

### With USB Transceiver (Figure 7)

The FAN3988 sets the FLAG1 pin to logic HIGH or LOW as an indicator to the system controller that a standard USB device or a charger is connected to the USB port. The FAN3988 also monitors the  $V_{BUS}$  for over- or under-voltage conditions. The FLAG2 pin is set LOW if  $V_{BUS}$  is less than 3.3V or greater than 6.0V.

In a standard USB configuration, there is a switch in the USB transceiver that is always ON in the full-speed mode. It is ON during the transition from full-speed mode to high-speed mode and is turned off after enumeration is complete.

In a condition where D+ and D- are shorted when a charger is plugged into the USB port, the USB switch is ON and pulled to  $V_{DD}$ , which is about 3V, making both D+ and D- HIGH and flag1 set HIGH – indicating that a charging device is connected to the port.

In a condition where D+ and D- are connected to a standard USB device, the D+ is pulled to  $V_{DD}$  and D- is set LOW (due to the 15K $\Omega$  pull-down on the USB device) and flag1 is LOW.

If D+ and D- are open (floating), D+ is pulled to  $V_{DD}$  and D- floats LOW, which makes flag1 LOW.

### Without USB Transceiver (Figure 8)

The FAN3988 sets the FLAG1 pin to logic HIGH or LOW as an indicator to the system controller that a standard USB device or a charger is connected to the USB port. The FAN3988 also monitors the  $V_{BUS}$  for over- or under-voltage conditions. The FLAG2 pin is set LOW if  $V_{BUS}$  is less than 3.3V or greater than 6.0V.

In a condition where a USB transceiver is not incorporated or there is a switch between the USB port and the FAN3988, external resistors must be used to set the correct input logic states on the FAN3988 D+ D- inputs. A 5M $\Omega$  pull-down on the D- line and a 1M $\Omega$  pull-up to  $V_{DD}$  (system supply) on the D+ line are recommended.

When a condition exists where a charger is plugged into the USB port (D+ D- shorted), the voltage divider of 1M and 5M puts a voltage of 2.3V on the D+ D- inputs and flag1 is HIGH, indicating a charger is connected to port.

In a condition where the USB port is connected to a standard USB device, the D+ input is pulled up to  $V_{DD}$  (system supply) in parallel with the 1.5K $\Omega$  on a USB transceiver with a parallel R value of 1.497K $\Omega$ . The D- input is connected to a 15K $\Omega$  pull-down by the USB device and in parallel with 5M $\Omega$  with a parallel R value of 14.955K $\Omega$ . This condition makes flag1 LOW.

If D+ and D- are open (floating), D+ is pulled to  $V_{DD}$  (system supply) and D- floats LOW, which makes flag1 LOW.

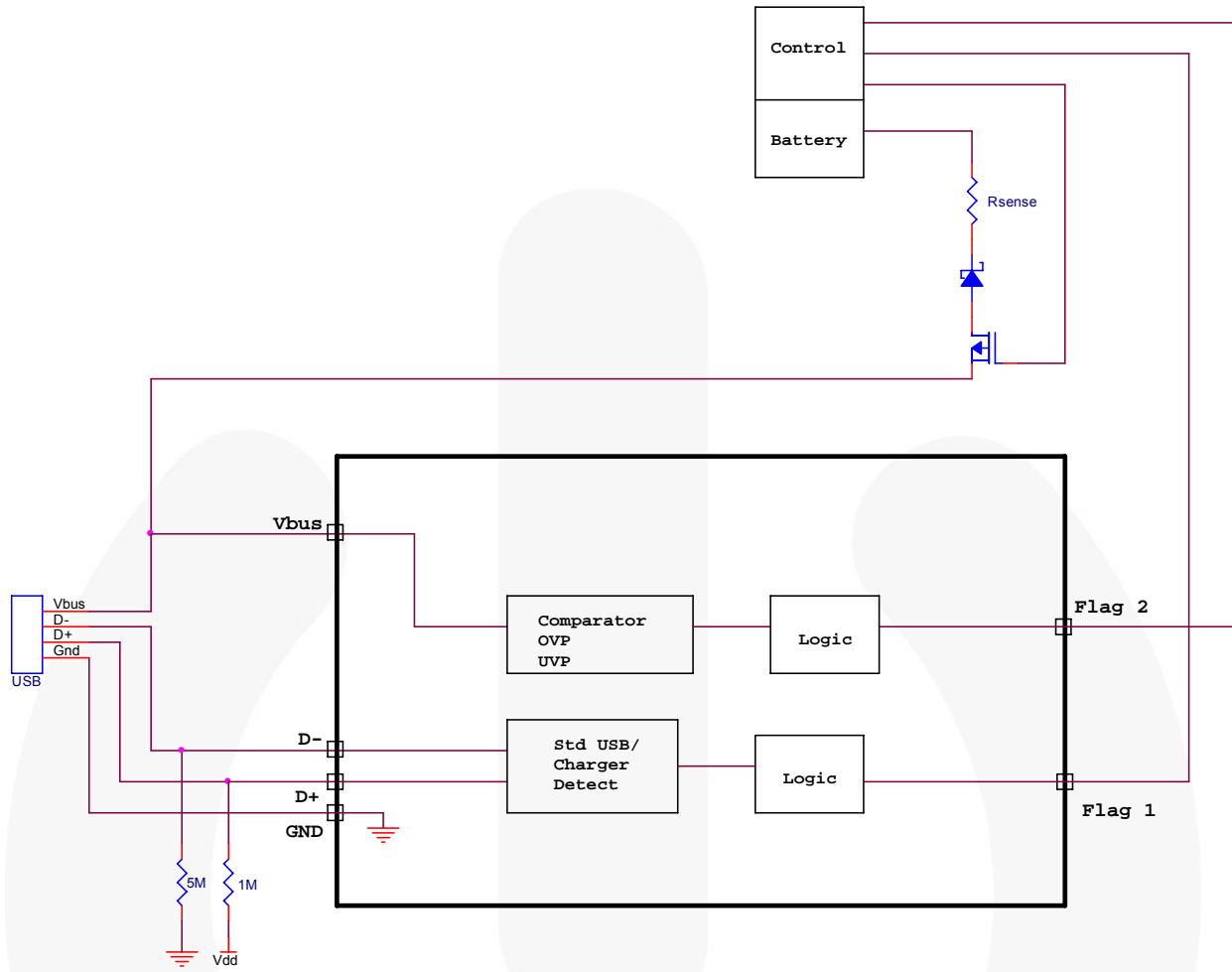
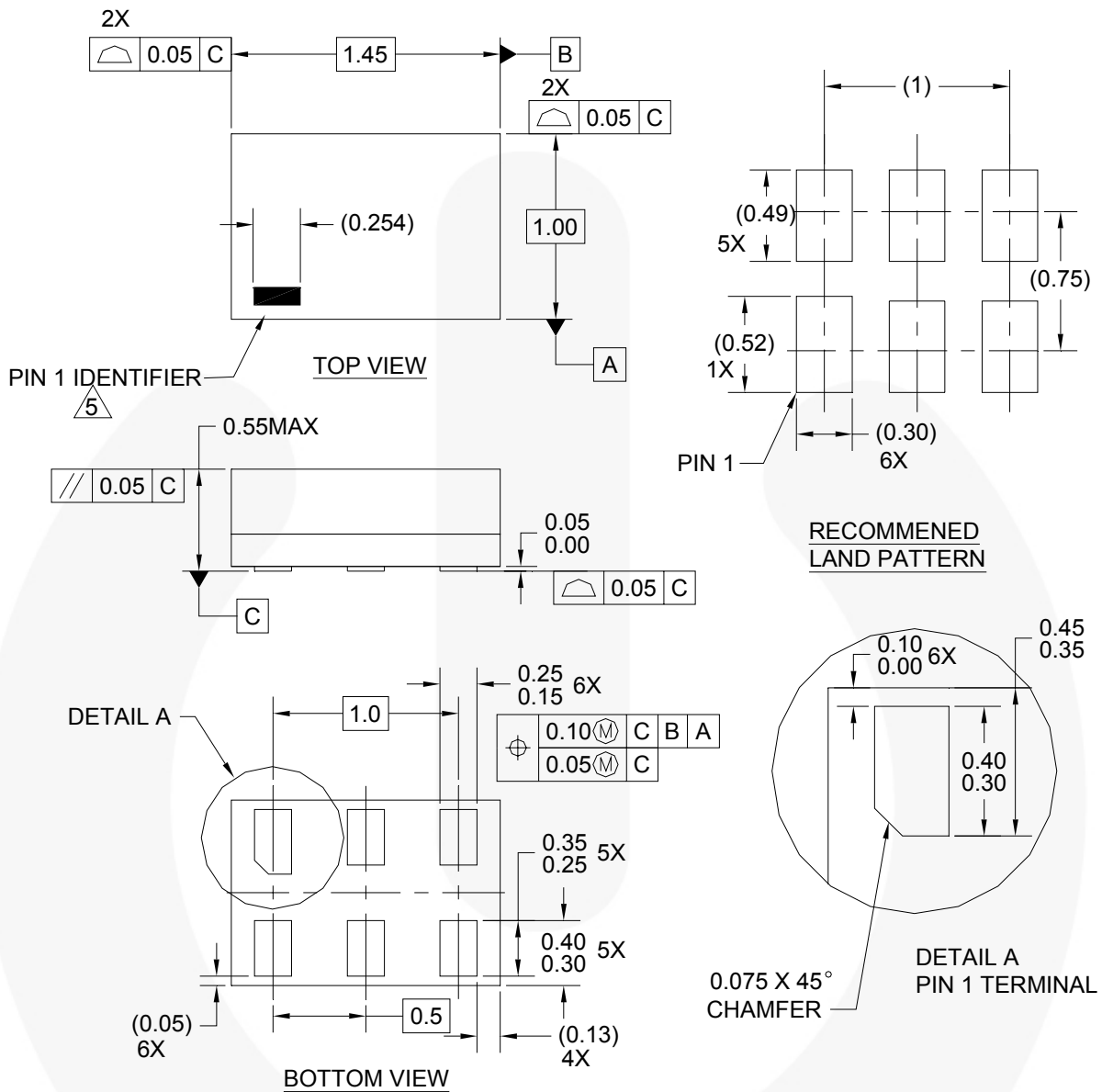

Figure 8. Typical System Application without USB Transceiver

Physical Dimensions



Notes:

1. CONFORMS TO JEDEC STANDARD M0-252 VARIATION UAAD
2. DIMENSIONS ARE IN MILLIMETERS
3. DRAWING CONFORMS TO ASME Y14.5M-1994
4. FILENAME AND REVISION: MAC06AREV4
5. PIN ONE IDENTIFIER IS 2X LENGTH OF ANY OTHER LINE IN THE MARK CODE LAYOUT.

Figure 9. 6-Lead MicroPak™ MLP Package

Package drawings are provided as a service to customers considering Fairchild components. Drawings may change in any manner without notice. Please note the revision and/or date on the drawing and contact a Fairchild Semiconductor representative to verify or obtain the most recent revision. Package specifications do not expand the terms of Fairchild's worldwide terms and conditions, specifically the warranty therein, which covers Fairchild products.

Always visit Fairchild Semiconductor's online packaging area for the most recent package drawings:  
<http://www.fairchildsemi.com/packaging/>







**TRADEMARKS**

The following includes registered and unregistered trademarks and service marks, owned by Fairchild Semiconductor and/or its global subsidiaries, and is not intended to be an exhaustive list of all such trademarks.

AccuPower™  
Auto-SPM™  
Build it Now™  
CorePLUS™  
CorePOWER™  
CROSSVOLT™  
CTL™  
Current Transfer Logic™  
DEUXPEED®  
Dual Cool™  
EcoSPARK®  
EfficientMax™  
ESBCT™  
**F**®  
Fairchild®  
Fairchild Semiconductor®  
FACT Quiet Series™  
FACT®  
FAST®  
FastvCore™  
FETBench™  
FlashWriter®  
FPS™

F-PFS™  
FRFET®  
Global Power Resource™  
Green FPST™  
Green FPST™ e-Series™  
Gmax™  
GTO™  
IntelliMAX™  
ISOPLANAR™  
MegaBuck™  
MICROCOUPLER™  
MicroFET™  
MicroPak™  
MicroPak2™  
MillerDrive™  
MotionMax™  
Motion-SPM™  
OptoHIT™  
OPTOLOGIC®  
OPTOPLANAR®  
PDP SPM™

Power-SPM™  
PowerTrench®  
PowerXS™  
Programmable Active Droop™  
QFET®  
QS™  
Quiet Series™  
RapidConfigure™  
™  
Saving our world, 1mW/W/kW at a time™  
SignalWise™  
SmartMax™  
SMART START™  
SPM®  
STEALTH™  
SuperFET™  
SuperSOT™-3  
SuperSOT™-6  
SuperSOT™-8  
SupreMOS®  
SyncFET™  
Sync-Lock™

**SYSTEM GENERAL**®  
The Power Franchise®  
**the power franchise**  
TinyBoost™  
TinyBuck™  
TinyCalc™  
TinyLogic®  
TINYOPTO™  
TinyPower™  
TinyPWM™  
TinyWire™  
TriFault Detect™  
TRUECURRENT™\*  
µSerDes™  
  
UHC®  
Ultra FRFET™  
UniFET™  
VCX™  
VisualMax™  
XS™

\* Trademarks of System General Corporation, used under license by Fairchild Semiconductor.

**DISCLAIMER**

FAIRCHILD SEMICONDUCTOR RESERVES THE RIGHT TO MAKE CHANGES WITHOUT FURTHER NOTICE TO ANY PRODUCTS HEREIN TO IMPROVE RELIABILITY, FUNCTION, OR DESIGN. FAIRCHILD DOES NOT ASSUME ANY LIABILITY ARISING OUT OF THE APPLICATION OR USE OF ANY PRODUCT OR CIRCUIT DESCRIBED HEREIN; NEITHER DOES IT CONVEY ANY LICENSE UNDER ITS PATENT RIGHTS, NOR THE RIGHTS OF OTHERS. THESE SPECIFICATIONS DO NOT EXPAND THE TERMS OF FAIRCHILD'S WORLDWIDE TERMS AND CONDITIONS, SPECIFICALLY THE WARRANTY THEREIN, WHICH COVERS THESE PRODUCTS.

**LIFE SUPPORT POLICY**

FAIRCHILD'S PRODUCTS ARE NOT AUTHORIZED FOR USE AS CRITICAL COMPONENTS IN LIFE SUPPORT DEVICES OR SYSTEMS WITHOUT THE EXPRESS WRITTEN APPROVAL OF FAIRCHILD SEMICONDUCTOR CORPORATION.

As used herein:

1. Life support devices or systems are devices or systems which, (a) are intended for surgical implant into the body or (b) support or sustain life, and (c) whose failure to perform when properly used in accordance with instructions for use provided in the labeling, can be reasonably expected to result in a significant injury of the user.
2. A critical component in any component of a life support, device, or system whose failure to perform can be reasonably expected to cause the failure of the life support device or system, or to affect its safety or effectiveness.

**ANTI-COUNTERFEITING POLICY**

Fairchild Semiconductor Corporation's Anti-Counterfeiting Policy. Fairchild's Anti-Counterfeiting Policy is also stated on our external website, [www.fairchildsemi.com](http://www.fairchildsemi.com), under Sales Support.

Counterfeiting of semiconductor parts is a growing problem in the industry. All manufacturers of semiconductor products are experiencing counterfeiting of their parts. Customers who inadvertently purchase counterfeit parts experience many problems such as loss of brand reputation, substandard performance, failed applications, and increased cost of production and manufacturing delays. Fairchild is taking strong measures to protect ourselves and our customers from the proliferation of counterfeit parts. Fairchild strongly encourages customers to purchase Fairchild parts either directly from Fairchild or from Authorized Fairchild Distributors who are listed by country on our web page cited above. Products customers buy either from Fairchild directly or from Authorized Fairchild Distributors are genuine parts, have full traceability, meet Fairchild's quality standards for handling and storage and provide access to Fairchild's full range of up-to-date technical and product information. Fairchild and our Authorized Distributors will stand behind all warranties and will appropriately address any warranty issues that may arise. Fairchild will not provide any warranty coverage or other assistance for parts bought from Unauthorized Sources. Fairchild is committed to combat this global problem and encourage our customers to do their part in stopping this practice by buying direct or from authorized distributors.

**PRODUCT STATUS DEFINITIONS**

**Definition of Terms**

Datasheet Identification	Product Status	Definition
Advance Information	Formative / In Design	Datasheet contains the design specifications for product development. Specifications may change in any manner without notice.
Preliminary	First Production	Datasheet contains preliminary data; supplementary data will be published at a later date. Fairchild Semiconductor reserves the right to make changes at any time without notice to improve design.
No Identification Needed	Full Production	Datasheet contains final specifications. Fairchild Semiconductor reserves the right to make changes at any time without notice to improve the design.
Obsolete	Not In Production	Datasheet contains specifications on a product that is discontinued by Fairchild Semiconductor. The datasheet is for reference information only.

Rev. 149