

CoolSET™ -F3 (Jitter Version)

ICE3B0365JG

ICE3B0565JG

Off-Line SMPS Current Mode
Controller with integrated 650V
Startup Cell/Depletion CoolMOS™

Power Management & Supply



Never stop thinking.

CoolSET™-F3

ICE3B0365JG / ICE3B0565JG

Revision History: 2006-11-14

Datasheet

Previous Version:1.1

Page	Subjects (major changes since last revision)
3, 4, 5, 19	Update to Pb-free package (PCN 2006-092-A)
6,8,12,13	Revise typo to the trigger level in Vsofts (C2) and VFB (C6a)
11	Revise typo in figure 13
15	Add pulse drain current
20,21	Add schematic for recommended PCB layout

For questions on technology, delivery and prices please contact the Infineon Technologies Offices in Germany or the Infineon Technologies Companies and Representatives worldwide: see our webpage at <http://www.infineon.com>

CoolMOS™, CoolSET™ are trademarks of Infineon Technologies AG.

Edition 2006-11-14

**Published by Infineon Technologies AG,
St.-Martin-Strasse 53,
D-81541 München**

**© Infineon Technologies AG 1999.
All Rights Reserved.**

Attention please!

The information herein is given to describe certain components and shall not be considered as warranted characteristics.

Terms of delivery and rights to technical change reserved.

We hereby disclaim any and all warranties, including but not limited to warranties of non-infringement, regarding circuits, descriptions and charts stated herein.

Infineon Technologies is an approved CECC manufacturer.

Information

For further information on technology, delivery terms and conditions and prices please contact your nearest Infineon Technologies Office in Germany or our Infineon Technologies Representatives worldwide (see address list).

Warnings

Due to technical requirements components may contain dangerous substances. For information on the types in question please contact your nearest Infineon Technologies Office.

Infineon Technologies Components may only be used in life-support devices or systems with the express written approval of Infineon Technologies, if a failure of such components can reasonably be expected to cause the failure of that life-support device or system, or to affect the safety or effectiveness of that device or system. Life support devices or systems are intended to be implanted in the human body, or to support and/or maintain and sustain and/or protect human life. If they fail, it is reasonable to assume that the health of the user or other persons may be endangered.

Off-Line SMPS Current Mode Controller with integrated 650V Startup Cell/Depletion CoolMOS™

Product Highlights

- **Active Burst Mode to reach the lowest Standby Power Requirements < 100mW**
- **Adjustable Blanking Window for High Load Jumps to increase Reliability**
- **Frequency Jittering for Low EMI**
- **Pb-free lead plating, RoHS compliant**

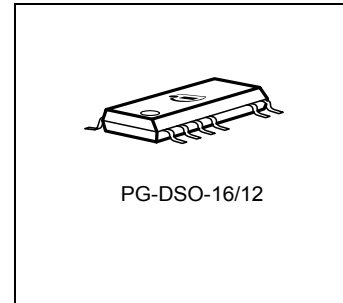

Features

- 650V Avalanche Rugged CoolMOS™ with built in switchable Startup Cell
- Active Burst Mode for lowest Standby Power @ light load controlled by Feedback Signal
- Fast Load Jump Response in Active Burst Mode
- 67 kHz fixed Switching Frequency
- Auto Restart Mode for Over temperature Detection
- Auto Restart Mode for Overvoltage Detection
- Auto Restart Mode for Overload and Open Loop
- Auto Restart Mode for VCC Undervoltage
- User defined Soft Start
- Minimum of external Components required
- Max Duty Cycle 75%
- Overall Tolerance of Current Limiting < ±5%
- Internal Leading Edge Blanking
- BiCMOS technology provides wide VCC Range
- Frequency jittering for Low EMI

Description

The CoolSET™-F3(Jitter version) meets the requirements for Off-Line Battery Adapters and low cost SMPS for the lower power range. By use of a BiCMOS technology a wide VCC range up to 26V is provided. This covers the changes in the auxiliary supply voltage if a CV/CC regulation is implemented on the secondary side. Furthermore an Active Burst Mode is integrated to fulfill the lowest Standby Power Requirements <100mW at no load and $V_{in} = 270VAC$. As during Active Burst Mode the controller is always active there is an immediate response on load jumps possible without any black out in the SMPS. In Active Burst Mode the ripple of the output voltage can be reduced <1%. Furthermore Auto Restart Mode is entered in case of Overtemperature, VCC Overvoltage, Output Open loop or Overload and VCC Undervoltage. By means of the internal precise peak current limitation, the dimension of the transformer and the secondary diode can be lowered which leads to more cost efficiency.

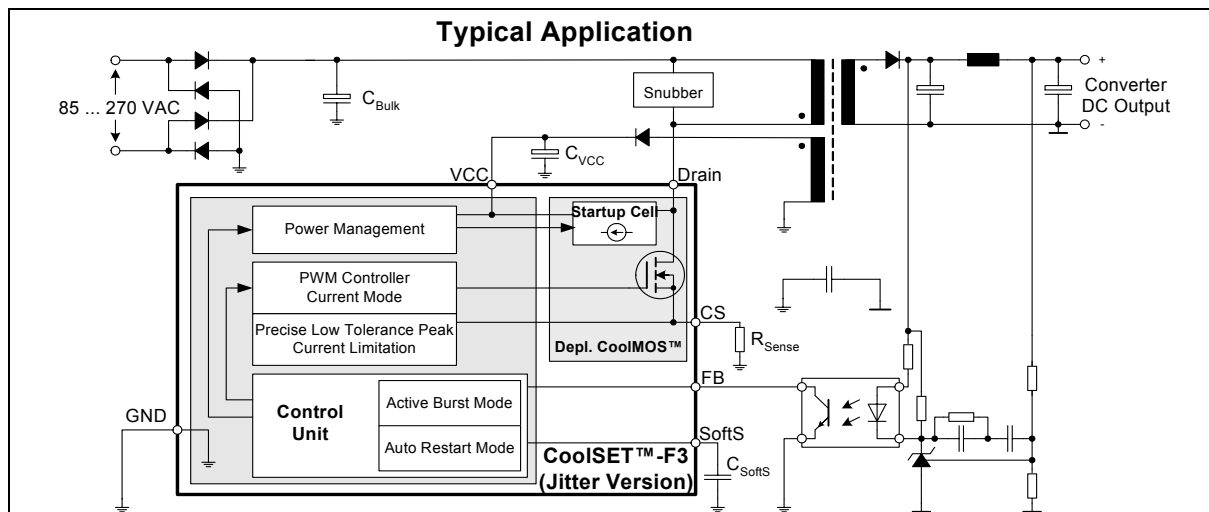

Type	Package	Marking	V_{DS}	F_{Osc}	$R_{DSon}^{1)}$	230VAC ±15% ²⁾	85-265 VAC ²⁾
ICE3B0365JG	PG-DSO-16/12	ICE3B0365JG	650V	67kHz	6.45Ω	22W	10W
ICE3B0565JG	PG-DSO-16/12	ICE3B0565JG	650V	67kHz	4.70Ω	25W	12W

¹⁾ typ @ T=25°C

²⁾ Calculated maximum input power rating at $T_a=75^\circ C$, $T_j=125^\circ C$ and without copper area as heat sink

Table of Contents	Page
1 Pin Configuration and Functionality	5
1.1 Pin Configuration with PG-DSO-16/12	5
1.2 Pin Functionality	5
2 Representative Blockdiagram	6
3 Functional Description	7
3.1 Introduction	7
3.2 Power Management	7
3.3 Startup Phase	8
3.4 PWM Section	9
3.4.1 Oscillator	9
3.4.2 PWM-Latch FF1	9
3.4.3 Gate Driver	9
3.5 Current Limiting	10
3.5.1 Leading Edge Blanking	10
3.5.2 Propagation Delay Compensation	10
3.6 Control Unit	11
3.6.1 Adjustable Blanking Window	11
3.6.2 Active Burst Mode	12
3.6.2.1 Entering Active Burst Mode	12
3.6.2.2 Working in Active Burst Mode	12
3.6.2.3 Leaving Active Burst Mode	12
3.6.3 Protection Modes	13
3.6.3.1 Auto Restart Mode	14
4 Electrical Characteristics	15
4.1 Absolute Maximum Ratings	15
4.2 Operating Range	15
4.3 Characteristics	16
4.3.1 Supply Section	16
4.3.2 Internal Voltage Reference	16
4.3.3 PWM Section	17
4.3.4 Control Unit	17
4.3.5 Current Limiting	18
4.3.6 CoolMOS™ Section	18
5 Outline Dimension	19
6 Schematic for recommended PCB layout	20

1 Pin Configuration and Functionality

1.1 Pin Configuration with PG-DSO-16/12

Pin	Symbol	Function
1	N.C.	Not Connected
2	SoftS	Soft-Start
3	FB	Feedback
4	CS	Current Sense/ 650V ¹⁾ Depl. CoolMOS™ Source
5	Drain	650V ¹⁾ Depl. CoolMOS™ Drain
6	Drain	650V ¹⁾ Depl. CoolMOS™ Drain
7	Drain	650V ¹⁾ Depl. CoolMOS™ Drain
8	Drain	650V ¹⁾ Depl. CoolMOS™ Drain
9	N.C.	Not Connected
10	N.C.	Not Connected
11	VCC	Controller Supply Voltage
12	GND	Controller Ground

¹⁾ at $T_j = 110^\circ\text{C}$

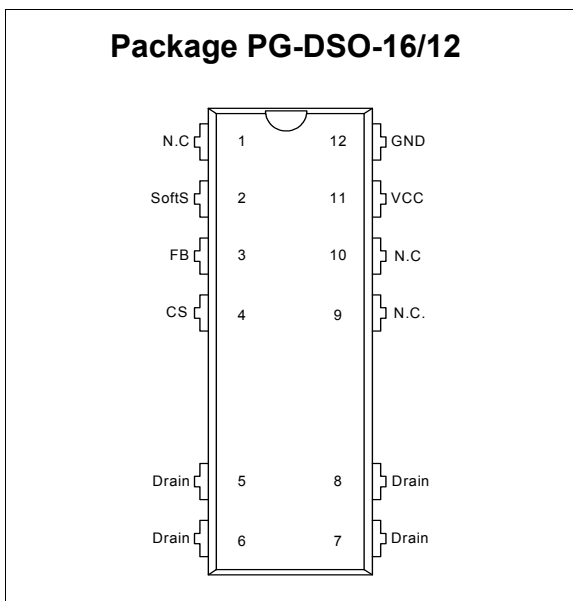

Figure 1 Pin Configuration PG-DSO-16/12

Note: Pin 5, 6, 7, and 8 are shorted within the package.

1.2 Pin Functionality

SoftS (Soft Start, Auto Restart & Frequency Jittering Control)

The SoftS pin combines the function of Soft Start during Start Up and error detection for Auto Restart Mode. These functions are implemented and can be adjusted by means of an external capacitor at SoftS to ground. This capacitor also provides an adjustable blanking window for high load jumps, before the IC enters into Auto Restart Mode. Furthermore this pin is also used to control the period of frequency jittering during normal load.

FB (Feedback)

The information about the regulation is provided by the FB Pin to the internal Protection Unit and to the internal PWM-Comparator to control the duty cycle. The FB-Signal controls in case of light load the Active Burst Mode of the controller.

CS (Current Sense)

The Current Sense pin senses the voltage developed on the series resistor inserted in the source of the integrated Depl-CoolMOS™. If CS reaches the internal threshold of the Current Limit Comparator, the Driver output is immediately switched off. Furthermore the current information is provided for the PWM-Comparator to realize the Current Mode.

Drain (Drain of integrated Depl. CoolMOS™)

Pin Drain is the connection to the Drain of the internal Depl. CoolMOS™.

VCC (Power supply)

The VCC pin is the positive supply of the IC. The operating range is between 10.3V and 26V.

GND (Ground)

The GND pin is the ground of the controller.

2 Representative Blockdiagram

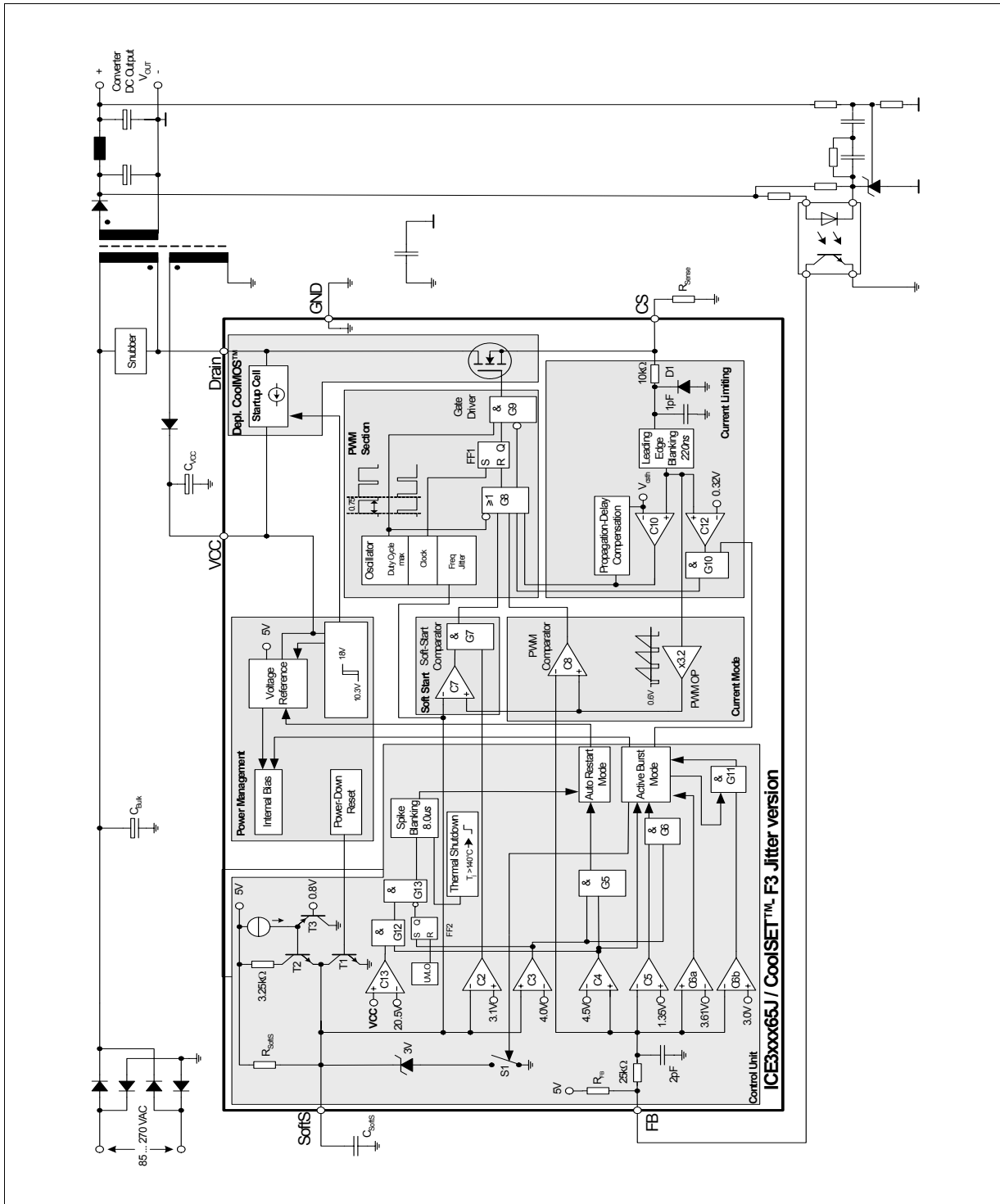

Figure 2 Representative Blockdiagram

When V_{VCC} falls below the off-threshold $V_{CCoff}=10.3V$ the bias circuit is switched off and the Power Down reset let T1 discharging the soft-start capacitor C_{SoftS} at pin SoftS. Thus it is ensured that at every startup cycle the voltage ramp at pin SoftS starts at zero.

The bias circuit is switched off if Auto Restart Mode is entered. The current consumption is then reduced to 300uA.

Once the malfunction condition is removed, this block will then turn back on. The recovery from Auto Restart Mode does not require disconnecting the SMPS from the AC line.

When Active Burst Mode is entered, some internal Bias is switched off in order to reduce the current consumption to about 500uA while keeping a comparator (which trigger if V_{FB} has exceeded 3.61V) and the Soft Start capacitor clamped at 3.0 V as this is necessary in this mode.

When the Soft Start begins, C_{SoftS} is immediately charged up to approx. 0.8V by T2. Therefore the Soft Start Phase takes place between 0.8V and 3.1V. Above $V_{SoftS} = 3.1V$ there is no longer duty cycle limitation DC_{max} which is controlled by comparator C7 since comparator C2 blocks the gate G7 (see Figure 5). This maximum charge current in the very first stage when V_{SoftS} is below 0.8V, is limited to 1.5mA.

3.3 Startup Phase

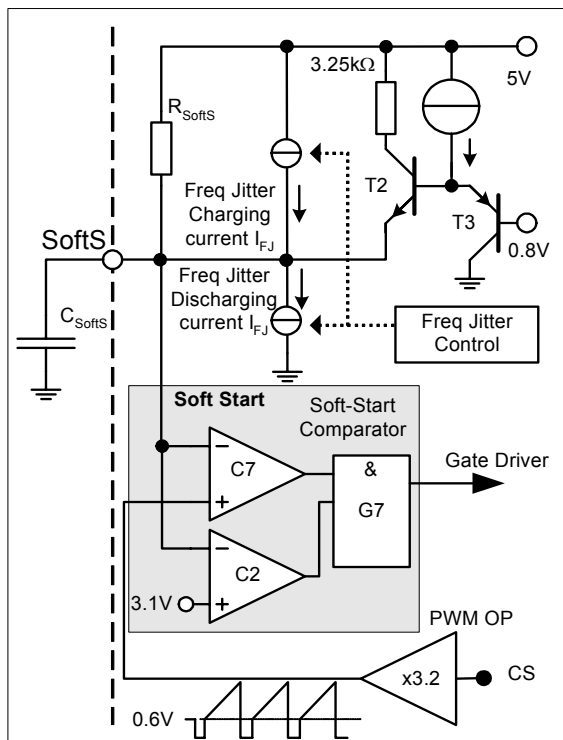

Figure 4 Soft Start

At the beginning of the Startup Phase, the IC provides a Soft Start duration whereby it controls the maximum primary current by means of a duty cycle limitation. A capacitor C_{SoftS} in combination with the internal pull up resistor R_{SoftS} determines the duty cycle until V_{SoftS} exceeds 3.1V.

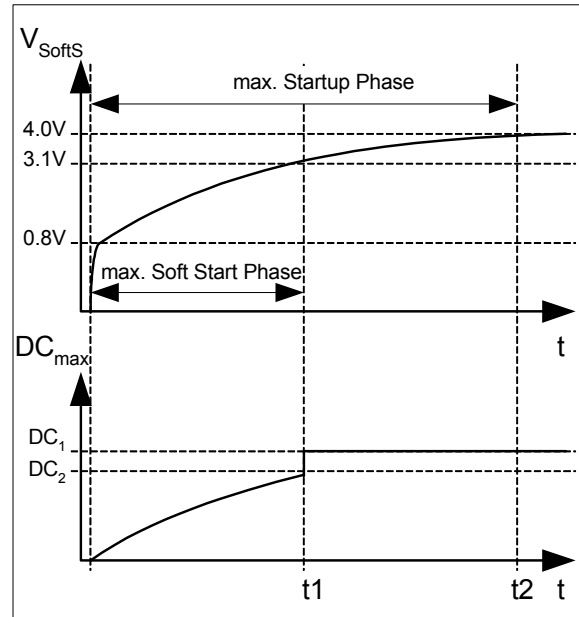

Figure 5 Startup Phase

By means of this extra charge stage, there is no delay in the beginning of the Startup Phase when there is still no switching. Furthermore Soft Start is finished at 3.1V to have faster the maximum power capability. The duty cycles DC_1 and DC_2 are depending on the mains and the primary inductance of the transformer. The limitation of the primary current by DC_2 is related to $V_{SoftS} = 3.1V$. But DC_1 is related to a maximum primary current which is limited by the internal Current Limiting with $CS = 1V$. Therefore the maximum Startup Phase is divided into a Soft Start Phase until t_1 and a phase from t_1 until t_2 where maximum power is provided if demanded by the FB signal.

3.4 PWM Section

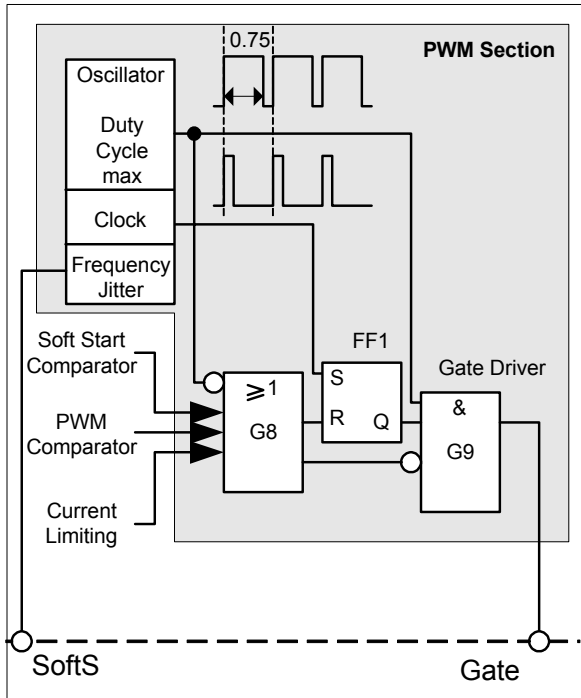

Figure 6 PWM Section

3.4.1 Oscillator and Jittering

The oscillator generates a fixed frequency with frequency jittering of $\pm 4\%$ from the fixed frequency (which is $\pm 2.7\text{kHz}$ from 67kHz) at a jittering period T_{FJ} . The switching frequency of ICE3B0x65JG is $f_{\text{switch}} = 67\text{kHz}$.

A resistor, a capacitor and a current source and current sink which determine the frequency are integrated. The charging and discharging current of the implemented oscillator capacitor are internally trimmed, in order to achieve a very accurate switching frequency. The ratio of controlled charge to discharge current is adjusted to reach a maximum duty cycle limitation of $D_{\text{max}}=0.75$.

Once the Soft Start period is over and when the IC goes into normal mode, the Soft Start capacitor will be charged and discharged through internal current source, I_{FJ} to generate a triangular waveform with a jittering period, T_{FJ} which is externally adjustable by the Soft Start capacitor, C_{SoftS} (See Figure 4).

$$T_{FJ} = k_{FJ} * C_{\text{SoftS}}$$

where k_{FJ} is a constant = 4 ms/uF

eg. $T_{FJ} = 4 \text{ ms}$ if $C_{\text{SoftS}} = 1 \text{ uF}$

3.4.2 PWM-Latch FF1

The oscillator clock output provides a set pulse to the PWM-Latch when initiating the internal CoolMOS™ conduction. After setting the PWM-Latch can be reset by the PWM comparator, the Soft Start comparator or the Current-Limit comparator. In case of resetting the driver is shut down immediately.

3.4.3 Gate Driver

The Gate Driver is a fast totem pole gate drive which is designed to avoid cross conduction currents.

The Gate Driver is active low at voltages below the undervoltage lockout threshold V_{VCCoff} .

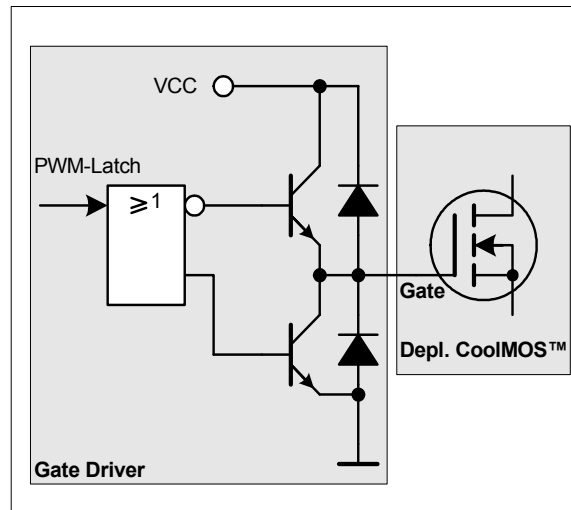

Figure 7 Gate Driver

3.5 Current Limiting

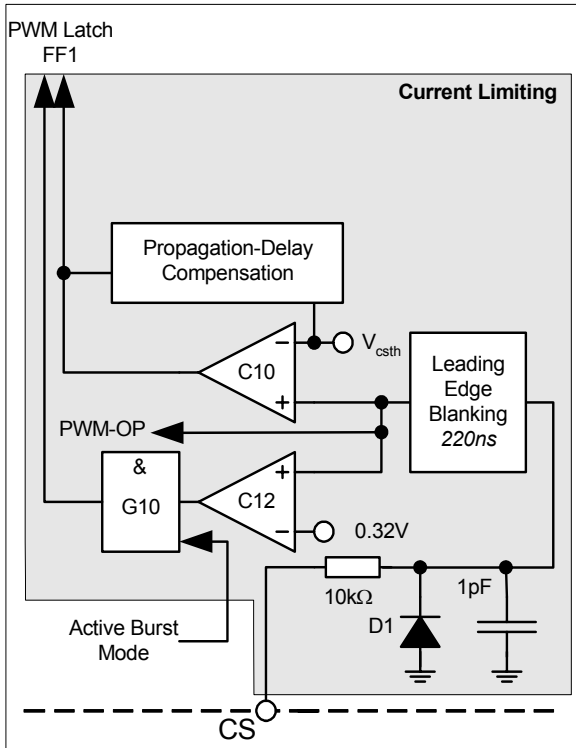

Figure 8 Current Limiting

There is a cycle by cycle Current Limiting realized by the Current-Limit comparator C10 to provide an overcurrent detection. The source current of the integrated Depl. CoolMOS™ is sensed via an external sense resistor R_{Sense} . By means of R_{Sense} the source current is transformed to a sense voltage V_{Sense} which is fed into the pin CS. If the voltage V_{Sense} exceeds the internal threshold voltage V_{csth} the comparator C10 immediately turns off the gate drive by resetting the PWM Latch FF1. A Propagation Delay Compensation is added to support the immediate shut down without delay of the integrated internal CoolMOS™ in case of Current Limiting. The influence of the AC input voltage on the maximum output power can thereby be avoided.

To prevent the Current Limiting from distortions caused by leading edge spikes a Leading Edge Blanking is integrated in the current sense path for the comparators C10, C12 and the PWM-OP.

The output of comparator C12 is activated by the Gate G10 if Active Burst Mode is entered. Once activated the current limiting is thereby reduced to 0.32V. This voltage level determines the power level when the Active Burst Mode is left if there is a higher power demand.

3.5.1 Leading Edge Blanking

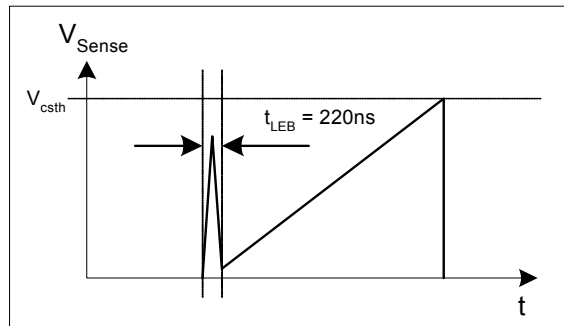

Figure 9 Leading Edge Blanking

Each time when the integrated internal CoolMOS™ is switched on a leading edge spike is generated due to the primary-side capacitances and secondary-side rectifier reverse recovery time. This spike can cause the gate drive to switch off unintentionally. To avoid a premature termination of the switching pulse, this spike is blanked out with a time constant of $t_{LEB} = 220ns$. During this time, the gate drive will not be switched off.

3.5.2 Propagation Delay Compensation

In case of overcurrent detection, the switch-off of the integrated internal CoolMOS™ is delayed due to the propagation delay of the circuit. This delay causes an overshoot of the peak current I_{peak} which depends on the ratio of dI/dt of the peak current (see Figure 10).

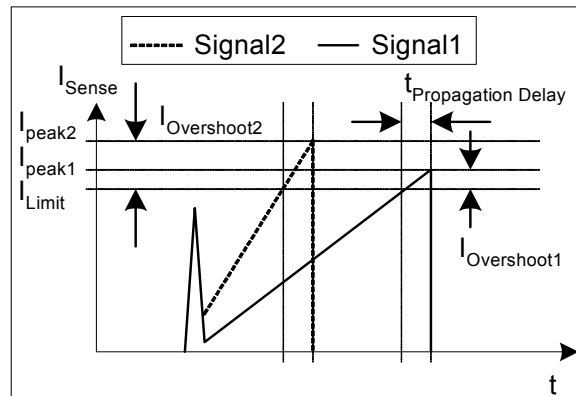

Figure 10 Current Limiting

The overshoot of Signal2 is bigger than of Signal1 due to the steeper rising waveform. This change in the slope is depending on the AC input voltage. Propagation Delay Compensation is integrated to limit the overshoot dependency on dI/dt of the rising primary current. That means the propagation delay time between exceeding the current sense threshold V_{csth} and the switch off of the integrated internal CoolMOS™ is compensated over temperature within a wide range.

Current Limiting is now possible in a very accurate way. E.g. $I_{peak} = 0.5A$ with $R_{Sense} = 2$. Without Propagation Delay Compensation the current sense threshold is set to a static voltage level $V_{csth} = 1V$. A current ramp of $di/dt = 0.4A/\mu s$, that means $dV_{Sense}/dt = 0.8V/\mu s$, and a propagation delay time of i.e. $t_{Propagation\ Delay} = 180ns$ leads then to an I_{peak} overshoot of 14.4%. By means of propagation delay compensation the overshoot is only about 2% (see Figure 11).

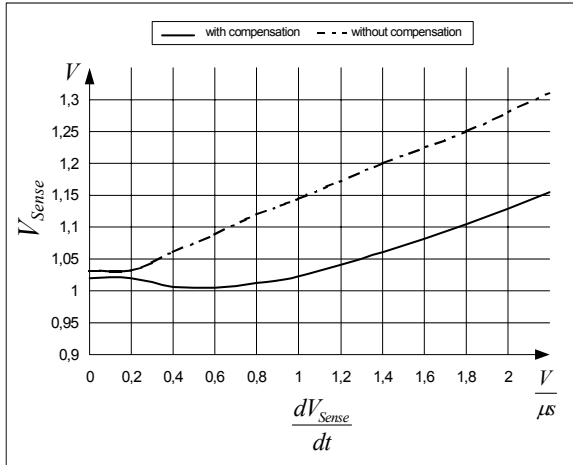

Figure 11 Overcurrent Shutdown

The Propagation Delay Compensation is realized by means of a dynamic threshold voltage V_{csth} (see Figure 12). In case of a steeper slope the switch off of the driver is earlier to compensate the delay.

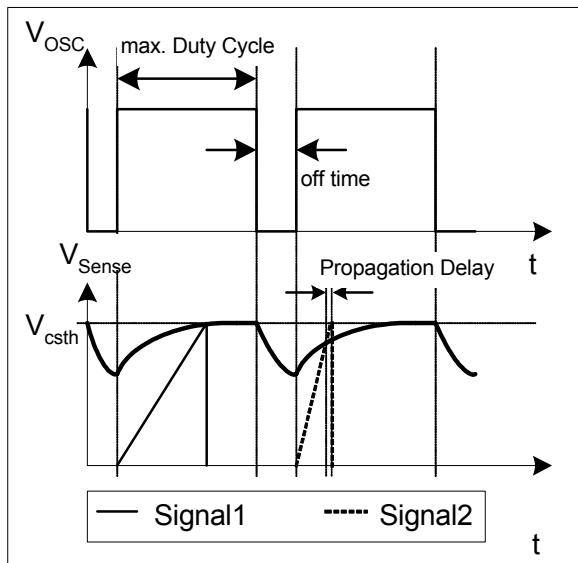

Figure 12 Dynamic Voltage Threshold V_{csth}

3.6 Control Unit

The Control Unit contains the functions for Active Burst Mode and Auto Restart Mode. The Active Burst Mode and the Auto Restart Mode are combined with an Adjustable Blanking Window which is depending on the external Soft Start capacitor. By means of this Adjustable Blanking Window, the IC avoids entering into these two modes accidentally. Furthermore it also provides a certain time whereby the overload detection is delayed. This delay is useful for applications which normally works with a low current and occasionally require a short duration of high current.

3.6.1 Adjustable Blanking Window

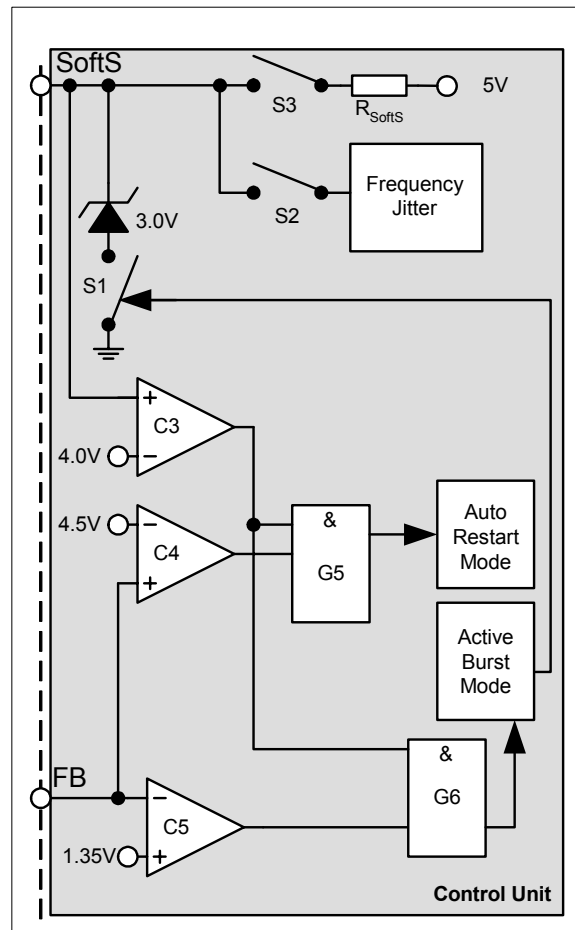

Figure 13 Adjustable Blanking Window

V_{SoftS} swings between 3.2V and 3.6V after the SMPS is settled and S2 is on while S3 is off, this is due to the frequency jittering function that is making use of the Soft Start pin. If overload occurs V_{FB} is exceeding 4.5V. Auto Restart Mode can't be entered as the gate G5 is still blocked by the comparator C3. But after V_{FB} has

exceeded 4.5V the switch S2 is opened and S3 is closed. The external Soft Start capacitor can now be charged further by the integrated pull up resistor R_{SoftS} via switch S3. The comparator C3 releases the gates G5 and G6 once V_{SoftS} has exceeded 4.0V. Therefore there is no entering of Auto Restart Mode possible during this charging time of the external capacitor C_{SoftS} . The same procedure happens to the external Soft Start capacitor if a low load condition is detected by comparator C5 when V_{FB} is falling below 1.35V. Only after V_{SoftS} has exceeded 4.0V and V_{FB} is still below 1.35V Active Burst Mode is entered.

3.6.2 Active Burst Mode

The controller provides Active Burst Mode for low load conditions at V_{OUT} . Active Burst Mode increases significantly the efficiency at light load conditions while supporting a low ripple on V_{OUT} and fast response on load jumps. During Active Burst Mode which is controlled only by the FB signal the IC is always active and can therefore immediately response on fast changes at the FB signal. The Startup Cell is kept switched off to avoid increased power losses for the self supply.

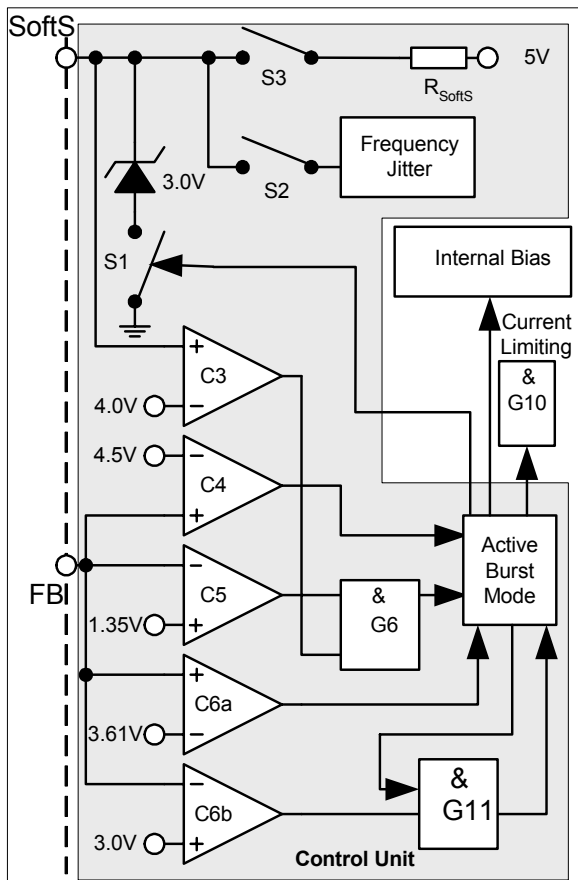

Figure 14 Active Burst Mode

The Active Burst Mode is located in the Control Unit. Figure 14 shows the related components.

3.6.2.1 Entering Active Burst Mode

The FB signal is always observed by the comparator C5 if the voltage level falls below 1.35V. In that case the switch S1 and S2 is released which allows the capacitor C_{SoftS} to be charged via S3 starting from the swinging voltage level between 3.2V and 3.6V in normal operating mode. If V_{SoftS} exceeds 4.0V the comparator C3 releases the gate G6 to enter the Active Burst Mode. The time window that is generated by combining the FB and SoftS signals with gate G6 avoids a sudden entering of the Active Burst Mode due to large load jumps. This time window can be adjusted by the external capacitor C_{SoftS} .

After entering Active Burst Mode a burst flag is set and the internal bias is switched off in order to reduce the current consumption of the IC down to approx. 500uA. Also, switch S1 is closed to clamped the Soft Start voltage to 3.0V. In this Off State Phase the IC is no longer self supplied so that therefore C_{VCC} has to provide the VCC current (see Figure 15). Furthermore gate G11 is then released to start the next burst cycle once V_{FB} has 3.0V exceeded.

It has to be ensured by the application that the VCC remains above the Undervoltage Lockout Level of 10.3V to avoid that the Startup Cell is accidentally switched on. Otherwise power losses are significantly increased. The minimum VCC level during Active Burst Mode is depending on the load conditions and the application. The lowest VCC level is reached at no load conditions at V_{OUT} .

3.6.2.2 Working in Active Burst Mode

After entering the Active Burst Mode the FB voltage rises as V_{OUT} starts to decrease due to the inactive PWM section. Comparator C6a observes the FB signal if the voltage level 3.6V is exceeded. In that case the internal circuit is again activated by the internal Bias to start with switching. As now in Active Burst Mode the gate G10 is released the current limit is only 0.32V to reduce the conduction losses and to avoid audible noise. If the load at V_{OUT} is still below the starting level for the Active Burst Mode the FB signal decreases down to 3.0V. At this level C6b deactivates again the internal circuit by switching off the internal Bias. The gate G11 is released as after entering Active Burst Mode the burst flag is set. If working in Active Burst Mode the FB voltage is changing like a saw tooth between 3.0V and 3.61V (see figure 15).

3.6.2.3 Leaving Active Burst Mode

The FB voltage immediately increases if there is a high load jump. This is observed by comparator C4. As the current limit is ca. 32% during Active Burst Mode a certain load jump is needed that FB can exceed 4.5V. At this time C4 resets the Active Burst Mode which also

blocks C12 by the gate G10. Maximum current can now be provided to stabilize V_{OUT} .

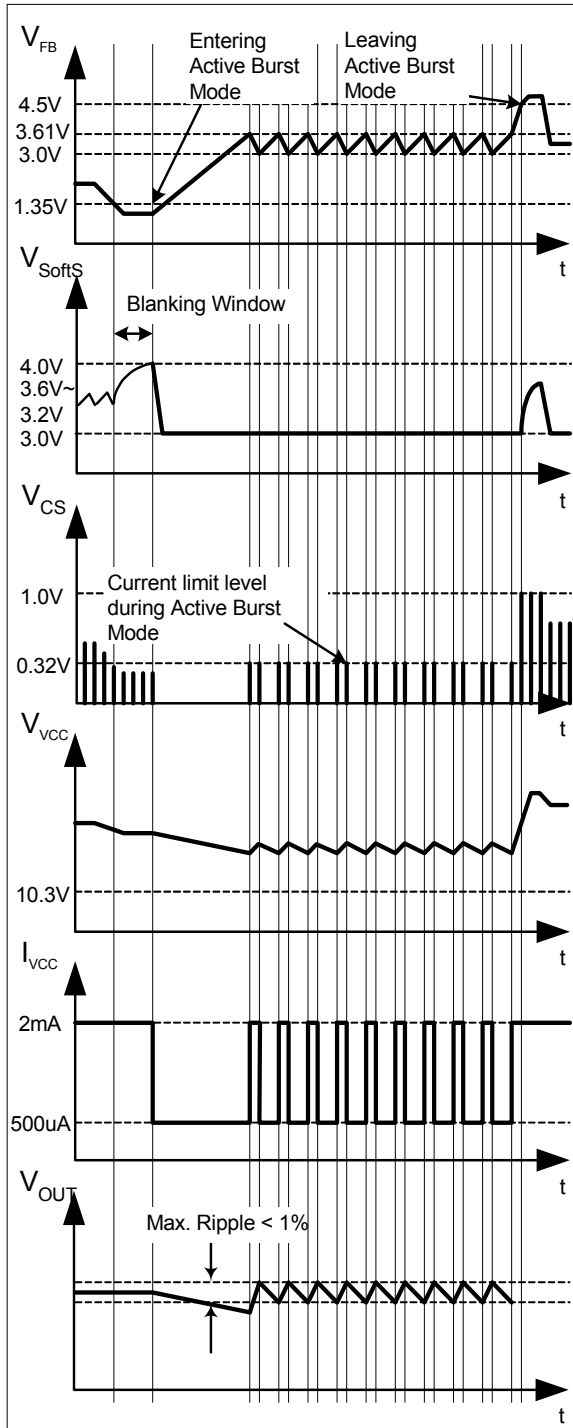

Figure 15 Signals in Active Burst Mode

3.6.3 Protection Modes

The IC provides several protection features that increase the SMPS system's robustness and safety. The following table shows the possible system failures and the corresponding protection modes.

VCC Overvoltage	Auto Restart Mode I
Over temperature	Auto Restart Mode I
Overload	Auto Restart Mode II
Open Loop	Auto Restart Mode II
VCC Undervoltage	Auto Restart Mode II
Short Optocoupler	Auto Restart Mode II

3.6.3.1 Auto Restart Mode I

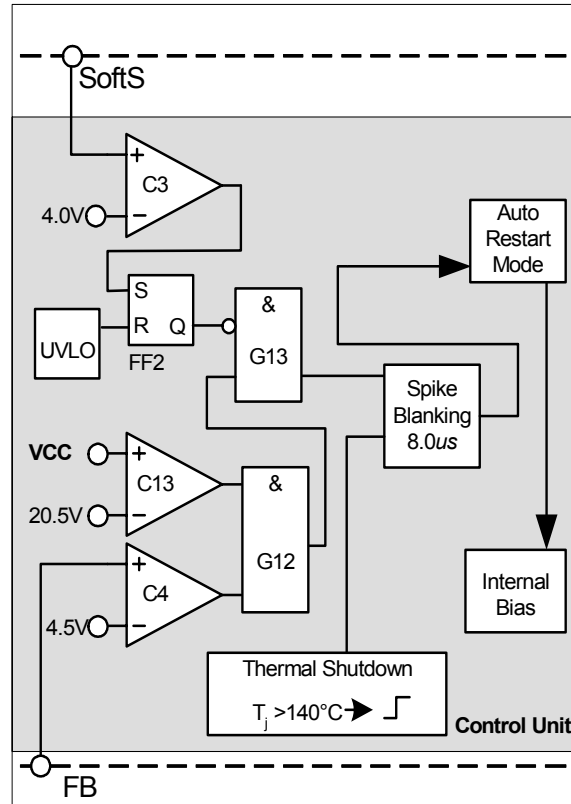

Figure 16 Auto Restart Mode I

The VCC voltage is observed by comparator C13 if 20.5V is exceeded. The output of C13 is combined with both the output of C3 which checks for $V_{SoftS} < 4.0V$ and the output of C4 which checks for $V_{FB} > 4.5V$. Therefore the overvoltage detection can only be active during Soft Start Phase ($V_{SoftS} < 4.0V$) and when FB signal is outside the operating range $> 4.5V$. This means any

small voltage overshoots of V_{VCC} during normal operating cannot trigger the Auto Restart Mode I.

In Order to ensure system reliability and prevent any false activation, a blanking time is implemented before the IC can enter into the Auto Restart Mode I. The output of the VCC overvoltage detection is fed into a spike blanking with a time constant of 8.0us.

The other fault detection which can result in the Auto Restart Mode I and has this 8.0us blanking time is the Overtemperature detection. This block checks for a junction temperature of higher than 140°C for malfunction operation.

Once Auto Restart Mode is entered, the internal bias is switched off in order to reduce the current consumption of the IC as much as possible. In this mode, the average current consumption is only 300uA as the only working blocks are the reference block and the Undervoltage Lockout(UVLO) which controls the Startup Cell by switching on/off at V_{VCCon}/V_{VCCoff} .

As there is no longer a self supply by the auxiliary winding, VCC starts to drop. The UVLO switches on the integrated Startup Cell when VCC falls below 10.3V. It will continue to charge VCC up to 18V whereby it is switched off again and the IC enters into the Start Up Phase.

As long as all fault conditions have been removed, the IC will automatically power up as usual with switching cycle at the GATE output after Soft Start duration. Thus the name Auto Restart Mode.

This charging of the Soft Start capacitor from 3.2V~3.6V to 4.0V defines a blanking window which prevents the system from entering into Auto Restart Mode II unintentionally during large load jumps. In this event, FB will rise close to 5.0V for a short duration before the loop regulates with FB less than 4.5V. This is the same blanking time window as for the Active Burst Mode and can therefore be adjusted by the external C_{SoftS} .

In case of VCC undervoltage, ie. VCC falls below 10.3V, the IC will be turned off with the Startup Cell charging VCC as described earlier in this section. Once VCC is charged above 18V, the IC will start a new startup cycle. The same procedure applies when the system is under Short Optocoupler fault condition, as it will lead to VCC undervoltage.

3.6.3.2 Auto Restart Mode II

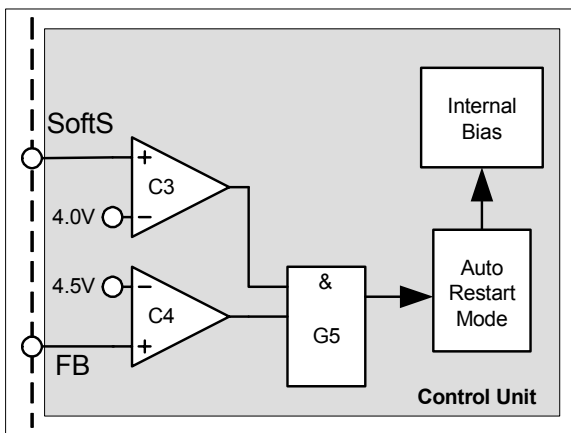

Figure 17 Auto Restart Mode II

In case of Overload or Open Loop, FB exceeds 4.5V which will be observed by C4. At this time, the external Soft Start capacitor can now be charged further by the integrated pull up resistor R_{SoftS} via switch S3 (see Figure 13). If V_{SoftS} exceeds 4.0V which is observed by C3, Auto Restart Mode II is entered as both inputs of the gate G5 are high.

4 Electrical Characteristics

Note: All voltages are measured with respect to ground (Pin 12). The voltage levels are valid if other ratings are not violated.

4.1 Absolute Maximum Ratings

Note: Absolute maximum ratings are defined as ratings, which when being exceeded may lead to destruction of the integrated circuit. For the same reason make sure, that any capacitor that will be connected to pin 11 (VCC) is discharged before assembling the application circuit.

Parameter	Symbol	Limit Values		Unit	Remarks
		min.	max.		
Drain Source Voltage	V_{DS}	-	650	V	$T_j = 110^\circ\text{C}$
Pulse drain current, t_p limited by max. $T_j=150^\circ\text{C}$	ICE3B0365JG I_{D_Puls1}	-	1.6	A	
	ICE3B0565JG I_{D_Puls2}	-	2.3	A	
Avalanche energy, repetitive t_{AR} limited by max. $T_j=150^\circ\text{C}^1$	ICE3B0365JG E_{AR1}	-	0.005	mJ	
	ICE3B0565JG E_{AR2}	-	0.01	mJ	
Avalanche current, repetitive t_{AR} limited by max. $T_j=150^\circ\text{C}^1$	ICE3B0365JG I_{AR1}	-	0.3	A	
	ICE3B0565JG I_{AR2}	-	0.5	A	
VCC Supply Voltage	V_{VCC}	-0.3	27	V	
FB Voltage	V_{FB}	-0.3	5.0	V	
SoftS Voltage	V_{SoftS}	-0.3	5.0	V	
CS Voltage	V_{CS}	-0.3	5.0	V	
Junction Temperature	T_j	-40	150	$^\circ\text{C}$	Controller & CoolMOS™
Storage Temperature	T_S	-55	150	$^\circ\text{C}$	
Thermal Resistance Junction-Ambient	R_{thJA}	-	110	K/W	PG-DSO-16/12
ESD Capability	V_{ESD}	-	2	kV	Human body model ²⁾

1) Repetitive avalanche causes additional power losses that can be calculated as $P_{AV}=E_{AR} \cdot f$

2) According to EIA/JESD22-A114-B (discharging a 100pF capacitor through a 1.5k Ω series resistor)

4.2 Operating Range

Note: Within the operating range the IC operates as described in the functional description.

Parameter	Symbol	Limit Values		Unit	Remarks
		min.	max.		
VCC Supply Voltage	V_{VCC}	V_{VCCoff}	26	V	
Junction Temperature of Controller	T_{jCon}	-25	130	$^\circ\text{C}$	Max value limited due to integrated thermal shut down
Junction Temperature of CoolMOS™	$T_{jCoolMOS}$	-25	150	$^\circ\text{C}$	

4.3 Characteristics

4.3.1 Supply Section

Note: The electrical characteristics involve the spread of values guaranteed within the specified supply voltage and junction temperature range T_J from $-25\text{ }^\circ\text{C}$ to $130\text{ }^\circ\text{C}$. Typical values represent the median values, which are related to $25\text{ }^\circ\text{C}$. If not otherwise stated, a supply voltage of $V_{CC} = 18\text{ V}$ is assumed.

Parameter	Symbol	Limit Values			Unit	Test Condition
		min.	typ.	max.		
Start Up Current	$I_{VCCstart}$	-	300	450	μA	$V_{VCC} = 17\text{V}$
VCC Charge Current	$I_{VCCcharge1}$	-	-	5.0	mA	$V_{VCC} = 0\text{V}$
	$I_{VCCcharge2}$	0.55	1.05	1.60	mA	$V_{VCC} = 1\text{V}$
	$I_{VCCcharge3}$	-	0.88	-	mA	$V_{VCC} = 17\text{V}$
Leakage Current of Start Up Cell & CoolMOS	$I_{StartLeak}$	-	0.2	50	μA	$V_{Drain} = 450\text{V}$ at $T_J = 100\text{ }^\circ\text{C}$
Supply Current with Inactive Gate	I_{VCCsup_ng}	-	1.7	2.5	mA	Soft Start pin is open
Supply Current with Active Gate	I_{VCCsup_g}	-	2.5	3.6	mA	$V_{SoftS} = 3.0\text{V}$ $I_{FB} = 0$
Supply Current in Auto Restart Mode with Inactive Gate	$I_{VCCrestart}$	-	300	-	μA	$I_{FB} = 0$ $I_{Softs} = 0$
Supply Current in Active Burst Mode with Inactive Gate	$I_{VCCburst1}$	-	500	950	μA	$V_{FB} = 2.5\text{V}$ $V_{SoftS} = 3.0\text{V}$
	$I_{VCCburst2}$	-	500	950	μA	$V_{VCC} = 11.5\text{V}$ $V_{FB} = 2.5\text{V}$ $V_{SoftS} = 3.0\text{V}$
VCC Turn-On Threshold	V_{VCCon}	17.0	18.0	19.0	V	
VCC Turn-Off Threshold	V_{VCCoff}	9.6	10.3	11.0	V	
VCC Turn-On/Off Hysteresis	V_{VCChys}	-	7.7	-	V	

4.3.2 Internal Voltage Reference

Parameter	Symbol	Limit Values			Unit	Test Condition
		min.	typ.	max.		
Trimmed Reference Voltage	V_{REF}	4.90	5.00	5.10	V	measured at pin FB $I_{FB} = 0$

4.3.3 PWM Section

Parameter	Symbol	Limit Values			Unit	Test Condition
		min.	typ.	max.		
Fixed Oscillator Frequency	f_{OSC3}	58	67	76	kHz	
	f_{OSC4}	62	67	74.5		
Frequency Jittering Range	f_{Δ}	-	± 2.7	-	kHz	$T_j = 25^\circ\text{C}$
Max. Duty Cycle	D_{max}	0.70	0.75	0.80		
Min. Duty Cycle	D_{min}	0	-	-		$V_{FB} < 0.3\text{V}$
PWM-OP Gain	A_V	3.0	3.2	3.4		
Max. Level of Voltage Ramp	$V_{Max-Ramp}$	-	0.6	-	V	
V_{FB} Operating Range Min Level	V_{FBmin}	-	0.5	-	V	
V_{FB} Operating Range Max level	V_{FBmax}	-	-	4.3	V	CS=1V limited by Comparator C4 ¹⁾
Feedback Pull-Up Resistor	R_{FB}	9	14	22	k Ω	
Soft-Start Pull-Up Resistor	R_{SoftS}	30	45	62	k Ω	

¹⁾ The parameter is not subjected to production test - verified by design/characterization

4.3.4 Control Unit

Parameter	Symbol	Limit Values			Unit	Test Condition
		min.	typ.	max.		
Deactivation Level for SoftS Comparator C7 by C2	$V_{SoftSC2}$	2.98	3.10	3.22	V	$V_{FB} = 5\text{V}$
Clamped V_{SoftS} Voltage during Burst Mode	$V_{SoftScImp_bm}$	2.88	3.00	3.12	V	
Activation Limit of Comparator C3	$V_{SoftSC3}$	3.85	4.00	4.15	V	$V_{FB} = 5\text{V}$
SoftS Startup Current	$I_{SoftSstart}$	-	0.9	-	mA	$V_{SoftS} = 0\text{V}$
Over Load & Open Loop Detection Limit for Comparator C4	V_{FBC4}	4.33	4.50	4.67	V	$V_{SoftS} = 4.5\text{V}$
Active Burst Mode Level for Comparator C5	V_{FBC5}	1.23	1.35	1.43	V	$V_{SoftS} = 4.5\text{V}$
Active Burst Mode Level for Comparator C6a	V_{FBC6a}	3.48	3.61	3.76	V	After Active Burst Mode is entered
Active Burst Mode Level for Comparator C6b	V_{FBC6b}	2.88	3.00	3.12	V	After Active Burst Mode is entered
Overvoltage Detection Limit	V_{VCCOVP}	19.5	20.5	21.5	V	$V_{FB} = 5\text{V}, V_{SoftS} = 3\text{V}$
Thermal Shutdown ¹⁾	T_{JSD}	130	140	150	$^\circ\text{C}$	
Spike Blanking	t_{Spike}	-	8.0	-	μs	

¹⁾ The parameter is not subjected to production test - verified by design/characterization

Note: The trend of all the voltage levels in the Control Unit is the same regarding the deviation except V_{VCCOVP}

4.3.5 Current Limiting

Parameter	Symbol	Limit Values			Unit	Test Condition
		min.	typ.	max.		
Peak Current Limitation (incl. Propagation Delay Time) (see Figure 11)	V_{csth}	1.02	1.07	1.12	V	$dV_{sense} / dt = 0.6V/\mu s$
Peak Current Limitation during Active Burst Mode	V_{CS2}	0.27	0.32	0.37	V	
Leading Edge Blanking	t_{LEB}	-	220	-	ns	$V_{SoftS} = 3.0V$
CS Input Bias Current	I_{CSbias}	-1.0	-0.2	0	μA	$V_{CS} = 0V$

4.3.6 CoolMOS™ Section

Parameter	Symbol	Limit Values			Unit	Test Condition	
		min.	typ.	max.			
Drain Source Breakdown Voltage	$V_{(BR)DSS}$	600	-	-	V	$T_j = 25^\circ C$	
		650	-	-	V	$T_j = 110^\circ C$	
Drain Source On-Resistance	ICE3B0365JG	R_{DSon1}	-	6.45	7.50	Ω	$T_j = 25^\circ C$
			-	13.70	17.00	Ω	$T_j = 125^\circ C^{1)}$
	ICE3B0565JG	R_{DSon2}	-	4.70	5.44	Ω	$T_j = 25^\circ C$
			-	10.00	12.50	Ω	$T_j = 125^\circ C^{1)}$
Effective output capacitance, energy related	ICE3B0365JG	$C_{o(er)1}$	-	3.65	-	pF	$V_{DS} = 0V$ to 480V
	ICE3B0565JG	$C_{o(er)2}$	-	4.75	-	pF	$V_{DS} = 0V$ to 480V
Rise Time	t_{rise}	-	30 ²⁾	-	ns		
Fall Time	t_{fall}	-	30 ²⁾	-	ns		

1) The parameter is not subjected to production test - verified by design/characterization

2) Measured in a Typical Flyback Converter Application

5 Outline Dimension

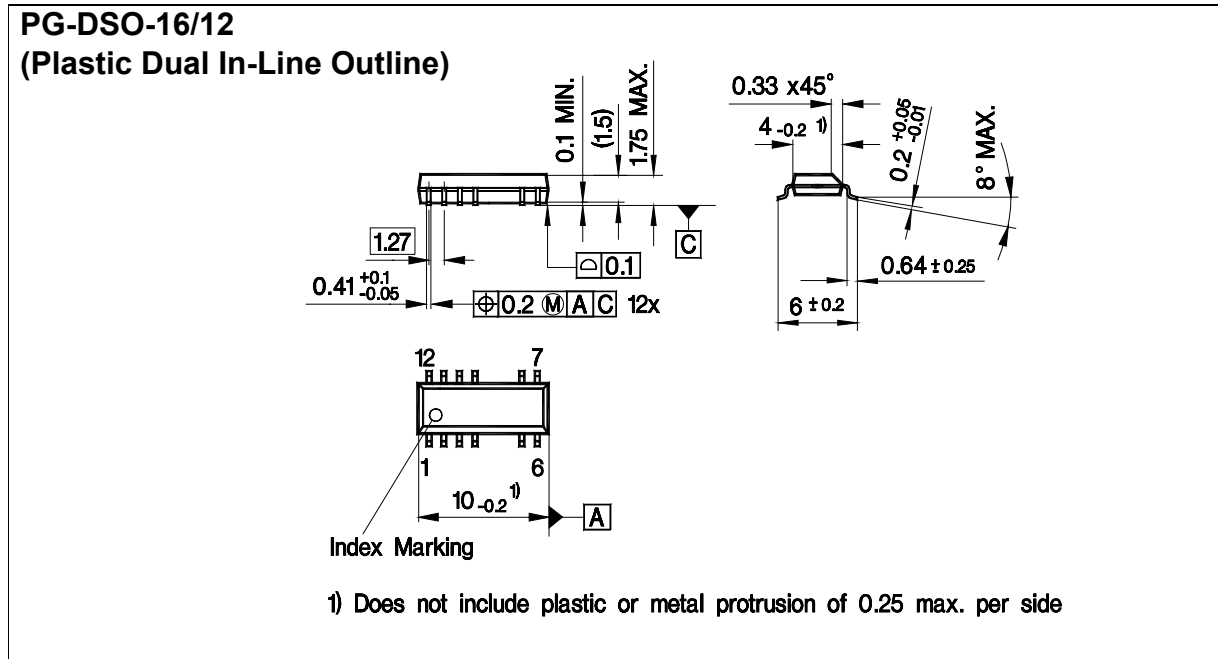

Figure 18 PG-DSO-16/12

Dimensions in mm

6 Schematic for recommended PCB layout

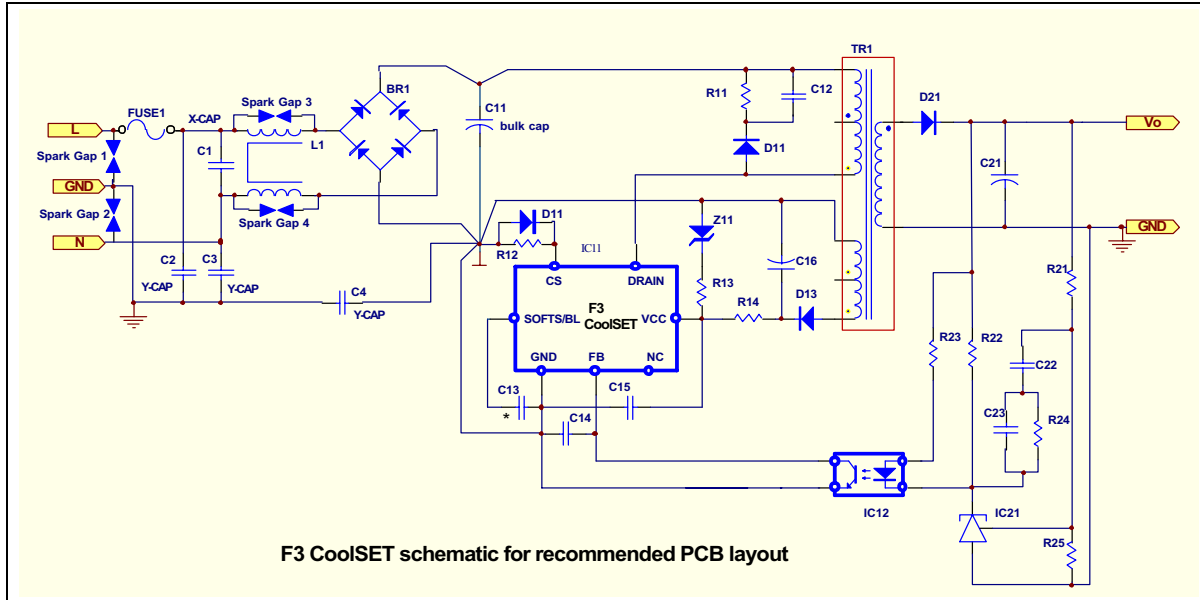

Figure 19 Schematic for recommended PCB layout

General guideline for PCB layout design using F3 CoolSET (refer to Figure 19):

1. "Star Ground" at bulk capacitor ground, C11:

"Star Ground" means all primary DC grounds should be connected to the ground of bulk capacitor C11 separately in one point. It can reduce the switching noise going into the sensitive pins of the CoolSET device effectively. The primary DC grounds include the followings.

- a. DC ground of the primary auxiliary winding in power transformer, TR1, and ground of C16 and Z11.
 - b. DC ground of the current sense resistor, R12
 - c. DC ground of the CoolSET device, GND pin of IC11; the signal grounds from C13, C14, C15 and collector of IC12 should be connected to the GND pin of IC11 and then "star" connect to the bulk capacitor ground.
 - d. DC ground from bridge rectifier, BR1
 - e. DC ground from the bridging Y-capacitor, C4
2. High voltage traces clearance:

High voltage traces should keep enough spacing to the nearby traces. Otherwise, arcing would incur.

- a. 400V traces (positive rail of bulk capacitor C11) to nearby trace: > 2.0mm
 - b. 600V traces (drain voltage of CoolSET IC11) to nearby trace: > 2.5mm
3. Filter capacitor close to the controller ground:
- Filter capacitors, C13, C14 and C15 should be placed as close to the controller ground and the controller pin as possible so as to reduce the switching noise coupled into the controller.

Guideline for PCB layout design when >3KV lightning surge test applied (refer to Figure 19):

1. Add spark gap

Spark gap is a pair of saw-tooth like copper plate facing each other which can discharge the accumulated charge during surge test through the sharp point of the saw-tooth plate.

- a. Spark Gap 3 and Spark Gap 4, input common mode choke, L1:
Gap separation is around 1.5mm (no safety concern)

Schematic for recommended PCB layout

b. Spark Gap 1 and Spark Gap 2, Live / Neutral to GROUND:

These 2 Spark Gaps can be used when the lightning surge requirement is >6KV.

230Vac input voltage application, the gap separation is around 5.5mm

115Vac input voltage application, the gap separation is around 3mm

2. Add Y-capacitor (C2 and C3) in the Live and Neutral to ground even though it is a 2-pin input

3. Add negative pulse clamping diode, D11 to the Current sense resistor, R12:

The negative pulse clamping diode can reduce the negative pulse going into the CS pin of the CoolSET and reduce the abnormal behavior of the CoolSET. The diode can be a fast speed diode such as IN4148.

The principle behind is to drain the high surge voltage from Live/Neutral to Ground without passing through the sensitive components such as the primary controller, IC11.

Total Quality Management

Qualität hat für uns eine umfassende Bedeutung. Wir wollen allen Ihren Ansprüchen in der bestmöglichen Weise gerecht werden. Es geht uns also nicht nur um die Produktqualität – unsere Anstrengungen gelten gleichermaßen der Lieferqualität und Logistik, dem Service und Support sowie allen sonstigen Beratungs- und Betreuungsleistungen.

Dazu gehört eine bestimmte Geisteshaltung unserer Mitarbeiter. Total Quality im Denken und Handeln gegenüber Kollegen, Lieferanten und Ihnen, unserem Kunden. Unsere Leitlinie ist jede Aufgabe mit „Null Fehlern“ zu lösen – in offener Sichtweise auch über den eigenen Arbeitsplatz hinaus – und uns ständig zu verbessern.

Unternehmensweit orientieren wir uns dabei auch an „top“ (Time Optimized Processes), um Ihnen durch größere Schnelligkeit den entscheidenden Wettbewerbsvorsprung zu verschaffen.

Geben Sie uns die Chance, hohe Leistung durch umfassende Qualität zu beweisen.

Wir werden Sie überzeugen.

Quality takes on an all-encompassing significance at Semiconductor Group. For us it means living up to each and every one of your demands in the best possible way. So we are not only concerned with product quality. We direct our efforts equally at quality of supply and logistics, service and support, as well as all the other ways in which we advise and attend to you.

Part of this is the very special attitude of our staff. Total Quality in thought and deed, towards co-workers, suppliers and you, our customer. Our guideline is “do everything with zero defects”, in an open manner that is demonstrated beyond your immediate workplace, and to constantly improve.

Throughout the corporation we also think in terms of Time Optimized Processes (top), greater speed on our part to give you that decisive competitive edge.

Give us the chance to prove the best of performance through the best of quality – you will be convinced.

<http://www.infineon.com>

Published by Infineon Technologies AG