

- SEE SHEET 2 FOR RECOMMENDED P.C. BOARD LAYOUT. TRUE POSITION TOLERANCE FOR P.C. BOARD LAYOUT IS .010 (0.25) AT MAX MATERIAL CONDITION. SUGGESTED BOARD THICKNESS IS .062 (1.57).
- THE CONNECTORS DESCRIBED IN THIS DOCUMENT MEET THE REQUIREMENTS OF MIL-C-24308 AND MATE WITH ANY PLUG CONNECTOR WITH SAME INSERT ARRANGEMENT.
- MARKED WITH .047 (1.19)±.062 (1.57) HIGH CHARACTERS. FAR SIDE REFERS TO THE WIDE SIDE OF THE KEYSTONE. NEAR SIDE REFERS TO THE NARROW SIDE OF THE KEYSTONE. IF THE REAR SHELL IS TOO SMALL FOR THE ENTIRE MILITARY PART NUMBER, MARKING SHALL BE LOCATED AS FOLLOWS:
  - A. "M24308" ON FRONT SHELL, FAR SIDE.
  - B. SLASH SHEET AND DASH NUMBER ON REAR SHELL, FAR SIDE.
  - C. "TYCD" AND DATE CODE ON FRONT SHELL, NEAR SIDE.
  - D. TYCD PART NUMBER ON REAR SHELL, NEAR SIDE.
- IF THE FRONT SHELL IS TOO SMALL FOR "TYCD", TYCD PART NUMBER AND DATE CODE, MARKING SHALL BE SPLIT AS FOLLOWS:
  - A. TYCD PART NUMBER ON REAR SHELL, NEAR SIDE.
  - B. "TYCD" AND DATE CODE ON FRONT SHELL, NEAR SIDE.
  - C. MILITARY PART NUMBER ON REAR SHELL, FAR SIDE.
- POINT OF ELECTRICAL ENGAGEMENT - AS MEASURED WITH A .0390-.0393 (0.991-0.998) DIA SQUARE ENDED PIN.
- SOLDER DIPPED PER J-STD-001 WITH Sn63 SOLDER PER J-STD-006 IN THE ENTIRE AREA OF DIMENSION SHOWN. (1757842-6 THRU -10 ONLY)
- MEETS SOLDERABILITY PER MIL-STD-202 METHOD 20B.

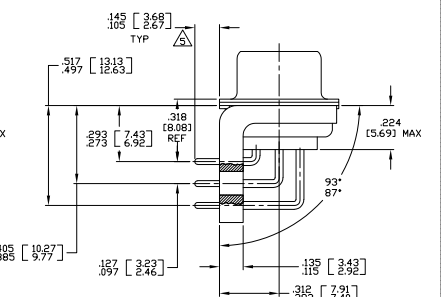

DIM J	DIM H	DIM E	DIM D	DIM C	DIM B	DIM A	NO. OF POSN	SHELL SIZE	MILITARY P/N ON CONNECTOR	TYCD P/N MARKED ON CONNECTOR	TYCD PART NO.								
.544	13.82	2.188	55.58	.620	15.75	.428	10.87	2.411	61.24	2.069	52.55	2.650	67.31	MS18277-1	50	5	M24308/23-41	1757842-5	1-1757842-0
.524	13.31	2.168	55.07	.590	14.99	.418	10.69	2.401	60.99	2.059	52.30	2.620	66.55	MS18276-1	37	4	M24308/23-40	1757842-4	1757842-9
.432	10.97	2.282	57.96	.509	12.93	.316	8.03	2.505	63.63	2.164	54.97	2.744	69.70	MS18275-1	25	3	M24308/23-39	1757842-3	1757842-8
.412	10.46	2.262	57.45	.479	12.17	.306	7.77	2.495	63.37	2.154	54.71	2.714	68.94	MS18274-1	15	2	M24308/23-38	1757842-2	1757842-7
.332	10.97	1.635	41.53	.509	12.93	.316	8.03	1.857	47.17	1.516	38.51	2.103	53.42	MS18273-1	9	1	M24308/23-37	1757842-1	1757842-6
.412	10.46	1.615	41.02	.479	12.17	.306	7.77	1.847	46.91	1.506	38.25	2.073	52.65	MS18272-1	50	5	M24308/23-41	1757842-5	1757842-5
.412	10.46	1.073	27.25	.479	12.17	.306	7.77	1.307	33.20	.966	24.54	1.526	38.76	MS18271-1	25	3	M24308/23-39	1757842-3	1757842-3
.432	10.97	.769	19.53	.509	12.93	.316	8.03	.989	25.12	.648	16.46	1.228	31.19	MS18270-1	15	2	M24308/23-38	1757842-2	1757842-2
.412	10.46	.749	19.02	.479	12.17	.306	7.77	.979	24.87	.638	16.21	1.198	30.43	MS18273-1	9	1	M24308/23-37	1757842-1	1757842-1
.544	13.82	2.188	55.58	.620	15.75	.428	10.87	2.411	61.24	2.069	52.55	2.650	67.31	MS18277-1	50	5	M24308/23-41	1757842-5	1757842-5
.524	13.31	2.168	55.07	.590	14.99	.418	10.69	2.401	60.99	2.059	52.30	2.620	66.55	MS18276-1	37	4	M24308/23-40	1757842-4	1757842-5
.432	10.97	2.282	57.96	.509	12.93	.316	8.03	2.505	63.63	2.164	54.97	2.744	69.70	MS18275-1	25	3	M24308/23-39	1757842-3	1757842-4
.412	10.46	2.262	57.45	.479	12.17	.306	7.77	2.495	63.37	2.154	54.71	2.714	68.94	MS18274-1	15	2	M24308/23-38	1757842-2	1757842-3
.332	10.97	1.635	41.53	.509	12.93	.316	8.03	1.857	47.17	1.516	38.51	2.103	53.42	MS18273-1	9	1	M24308/23-37	1757842-1	1757842-3
.412	10.46	1.615	41.02	.479	12.17	.306	7.77	1.847	46.91	1.506	38.25	2.073	52.65	MS18272-1	50	5	M24308/23-41	1757842-5	1757842-2
.432	10.97	.769	19.53	.509	12.93	.316	8.03	.989	25.12	.648	16.46	1.228	31.19	MS18271-1	25	3	M24308/23-39	1757842-3	1757842-2
.412	10.46	.749	19.02	.479	12.17	.306	7.77	.979	24.87	.638	16.21	1.198	30.43	MS18270-1	15	2	M24308/23-38	1757842-2	1757842-1

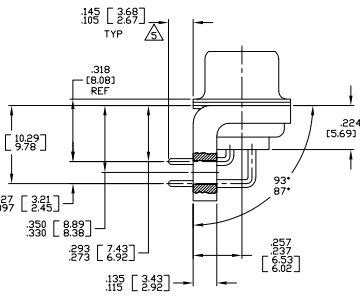
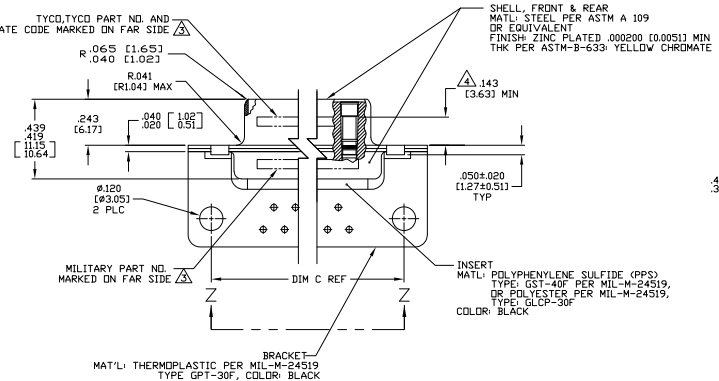
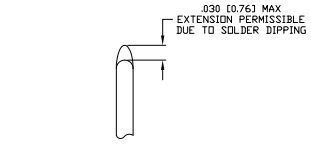

DETAIL K  
 SCALE 10:1  
 FOR 1757842-6 THRU -10 ONLY

THIS DRAWING IS A CONTROLLED DOCUMENT

REVISIONS: 1-22-96 CT DM

DESIGNED BY: J. MILLER

DATE: 1-22-96

DRAWN BY: J. MILLER

DATE: 1-22-96

CHECKED BY: J. MILLER

DATE: 1-22-96

APPROVED BY: J. MILLER

DATE: 1-22-96

CUSTOMER DRAWING: A100779 (G=1757842)

RECEPTACLE ASSEMBLY, AMP/LITE, RT ANGLE, SERIES 109, SIZE 1 THRU 5

REVISIONS: 1-22-96 CT DM

THIS DRAWING IS UNPUBLISHED  
 © AMP INC. ALL RIGHTS RESERVED

REV	DATE	DESCRIPTION	BY	CHK	APP
DF	DO				
		SEE SHEET 1			

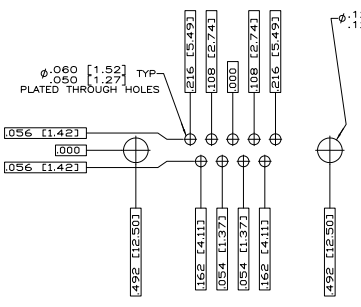

RECOMMENDED P.C. BOARD LAYOUT  
 SHELL SIZE 1 (9 POSITION) Δ

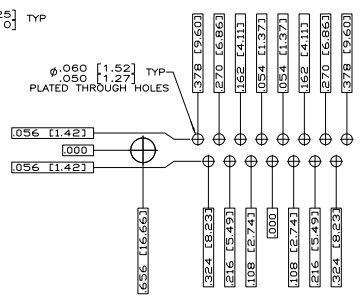

RECOMMENDED P.C. BOARD LAYOUT  
 SHELL SIZE 2 (15 POSITION) Δ

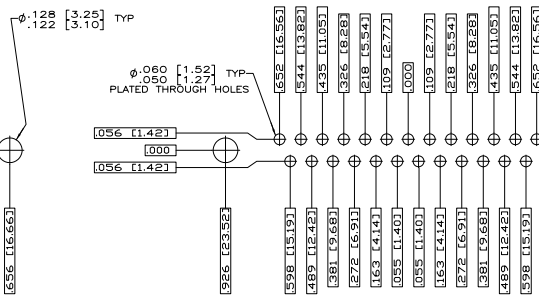

RECOMMENDED P.C. BOARD LAYOUT  
 SHELL SIZE 3 (25 POSITION) Δ

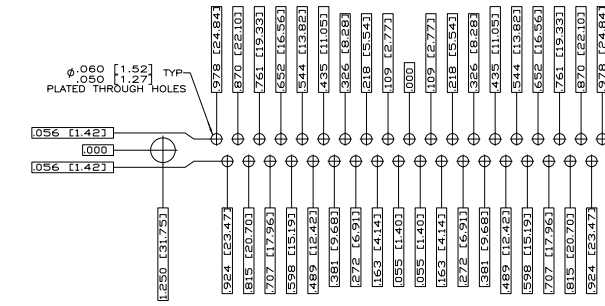

RECOMMENDED P.C. BOARD LAYOUT  
 SHELL SIZE 4 (37 POSITION) Δ

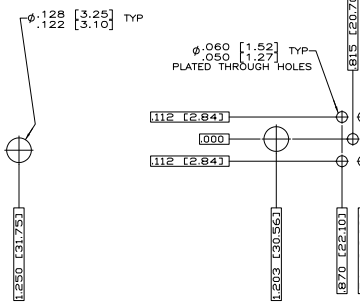

RECOMMENDED P.C. BOARD LAYOUT  
 SHELL SIZE 5 (50 POSITION) Δ

THIS DRAWING IS A CONTROLLED DOCUMENT.		AMP	
DESIGNED BY: THOMAS	DATE: 2-27-74	AMP Inc. Harrisburg, PA 17105-3608	
DRAWN BY: JOSEPHMAN	DATE: 2-27-74	RECEPTACLE ASSEMBLY-AMPLIMITE	
CHECKED BY: MILLER	DATE: 2-27-74	RIGHT ANGLE SERIES 109 SIZE	
APPROVED BY: [Signature]	DATE: 2-27-74	1 THRU 5	
SEE CALLOUTS	SEE CALLOUTS	SIZE: A1	DATE: 100779
		SHEET: 4.1	TOTAL SHEETS: 2