

REV	DATE	DESCRIPTION	BY	CHK	APP
DF	DO				
		SEE SHEET 1			

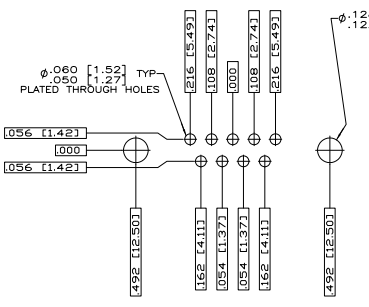

RECOMMENDED P.C. BOARD LAYOUT SHELL SIZE 1 (9 POSITION) Δ

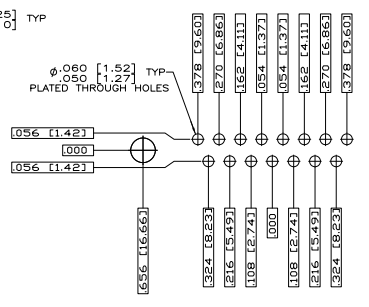

RECOMMENDED P.C. BOARD LAYOUT SHELL SIZE 2 (15 POSITION) Δ

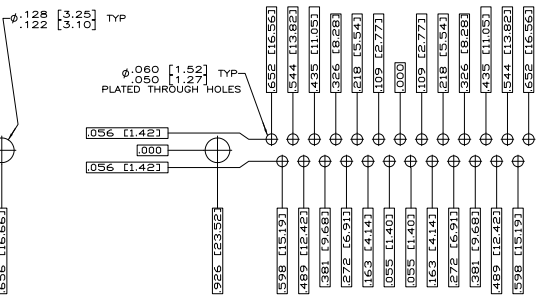

RECOMMENDED P.C. BOARD LAYOUT SHELL SIZE 3 (25 POSITION) Δ

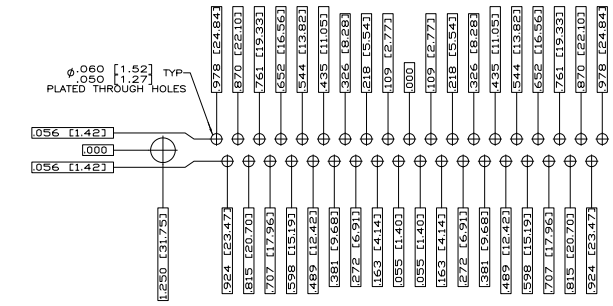

RECOMMENDED P.C. BOARD LAYOUT SHELL SIZE 4 (37 POSITION) Δ

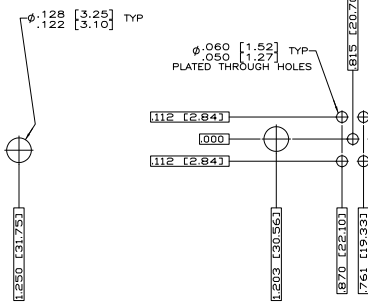

RECOMMENDED P.C. BOARD LAYOUT SHELL SIZE 5 (50 POSITION) Δ

THIS DRAWING IS A CONTROLLED DOCUMENT.		REV. C. THOMAS 2-27-74		AMP		Teco Electronics Corporation Harrisburg, PA 17105-3608	
DESIGNER	HOLES	DRUMMER LABELS	ROSEMAN	DATE	RECEPTACLE ASSEMBLY-AMPLIMITE RIGHT ANGLE SERIES 109, SIZE 1 THRU 5	SIZE	REWORKED TO
SEE CALLOUTS				100779	1757846	4.1	2