

4

3

2

1

THIS DRAWING IS UNPUBLISHED. RELEASED FOR PUBLICATION AUG. 2006.
 COPYRIGHT 2009 BY TYCO ELECTRONICS CORPORATION. ALL RIGHTS RESERVED.

LOC	DIST	REVISIONS				
P	LTR	DESCRIPTION	DATE	DWN	APVD	
DW	-	B	REVISED (ECR-10-009968)	10MAY10	JL	WK

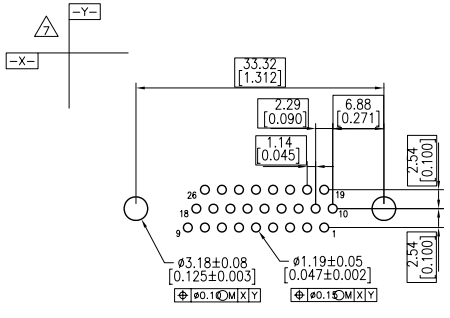
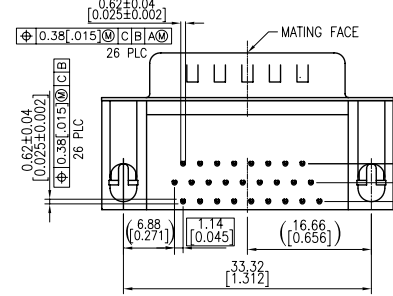
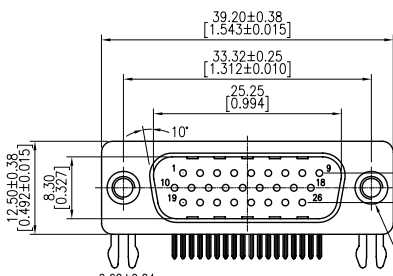
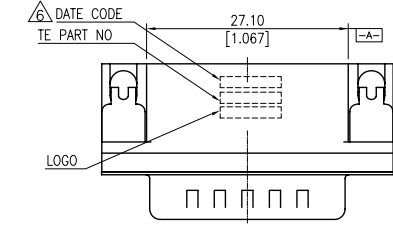

RECOMMENDED PCB LAYOUT

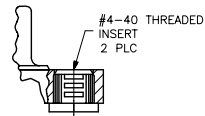
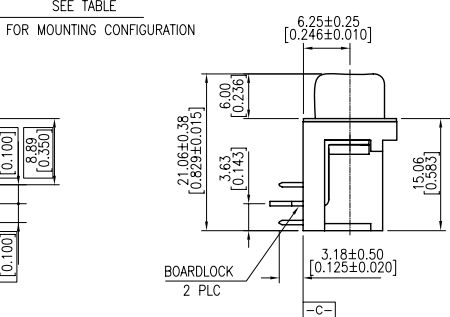

DETAIL A

- HOUSING: PBT, BLACK, UL94V-0.
- CONTACT: BRASS, GOLD PLATE IN THE MATING AREA (SEE TABLE), 120u" MINIMUM TIN PLATE ON THE SOLDER-TAIL BOTH OVER 50u" MINIMUM NICKEL UNDERPLATE.
- SHELL: STEEL, NICKEL PLATE.
- BOARDLOCK: BRASS, 100u" MINIMUM TIN PLATE
- THREADED INSERT: BRASS, NICKEL PLATE

△ FOUR DIGIT DATE CODE IN THIS FORMAT.
 01 45
 YEAR — MANUFACTURING WEEK
 △ DATUMS -X- & -Y- TO BE ESTABLISHED BY CUSTOMER.

STATUS	DESCRIPTION	MATERIAL	FINISH	PART NUMBER
OBSOLETE	TRAY	DETAIL A	GOLD FLASH	5749769-3
OBSOLETE	TRAY	DETAIL A	15μ" MIN	5749769-2
OBSOLETE	TRAY	DETAIL A	30μ" MIN	5749769-1
PACKAGING	MOUNTING FLANGE CONFIG	CONTACT MATING AREA FINISH		PART NUMBER

THIS DRAWING IS A CONTROLLED DOCUMENT.		R. RICHARDSON 22APR2005		Tyco Electronics Corporation Taipei, Taiwan	
DIMENSIONS: MM		S. BOLASH 22APR2005		NAME	
TOLERANCES UNLESS OTHERWISE SPECIFIED:		M. WALMSLEY 22APR2005		PRODUCT SPEC	
0 PLC ± .		APPLICATION SPEC		SIZE	
1 PLC ± 0.30		WEIGHT		CAGE CODE	
2 PLC ± 0.20		CUSTOMER DRAWING		DRAWING NO	
3 PLC ± 0.10		SCALE		RESTRICTED TO	
4 PLC ± .		SHEET		REV	
ANGLES ± 2"		1 of 2		B	
MATERIAL SEE NOTE		FINISH SEE NOTE		WEIGHT GRAMS	
		SIZE A3		CAGE CODE 00779	
		DRAWING NO		C=5749769	

4

3

2

1

THIS DRAWING IS UNPUBLISHED. RELEASED FOR PUBLICATION AUG. 2006.
 COPYRIGHT 2009 BY TYCO ELECTRONICS CORPORATION. ALL RIGHTS RESERVED.

LOC	DIST	REVISIONS			
P	LTR	DESCRIPTION	DATE	DWN	APVD
SEE SHEET 1.					

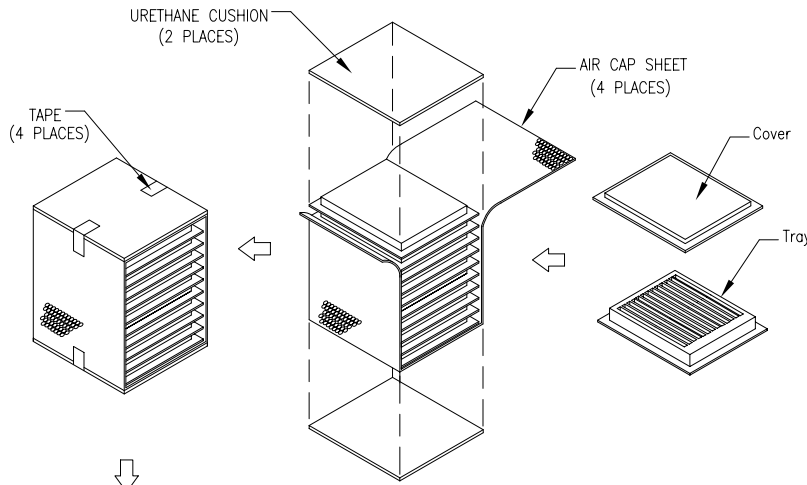

- NOTES:
- MATERIAL:
 - 1.1 TRAY: PVC
 - 1.2 SHIPPING CARTON: CORRUGATED FIBERBOARD
 - DIMENSION:
 - 2.1 TRAY: L=32.0X23.0X1.89 CM
 - 2.2 SHIPPING CARTON: L=36.1X24.5X27.2 CM
 - QUANTITY:
 - 3.1 PRIMARY PACKING: 80 PCS/TRAY
 - 3.2 SECONDARY PACKING: 10 TRAY/CARTON(800PCS)
 - WEIGHT:
 - 4.1 NET WEIGHT: 9.54 Kg
 - 4.2 GROSS WEIGHT: 11.54 Kg

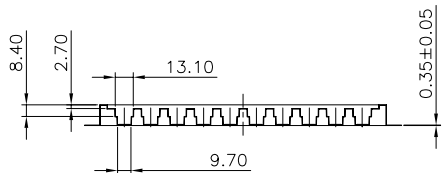
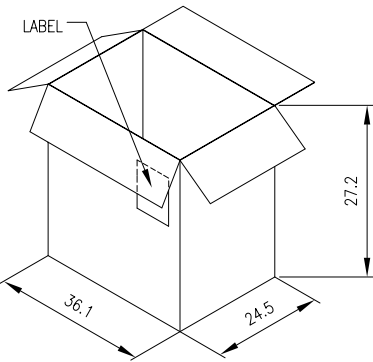
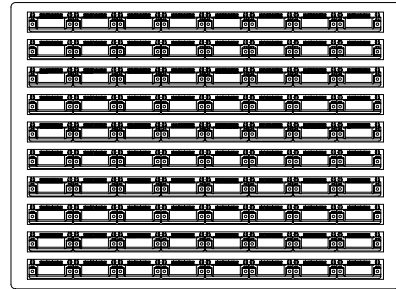

THIS DRAWING IS A CONTROLLED DOCUMENT.		DWN	Tyco Electronics Corporation Taipei, Taiwan	
DIMENSIONS: MM		CHK	NAME	
TOLERANCES UNLESS OTHERWISE SPECIFIED:		APVD	PLUG ASSEMBLY, RIGHT ANGLE, 26 POSITION, HD-22, AMPLIMITE	
0 PLC ± -		PRODUCT SPEC	SIZE	CAGE CODE
1 PLC ± -		APPLICATION SPEC	A3	00779
2 PLC ± -		WEIGHT	DRAWING NO	
3 PLC ± -		CUSTOMER DRAWING	C-5749769	
4 PLC ± -		SCALE	RESTRICTED TO	
ANGLES ± -		SHEET	2 of 2	
FINISH		REV	B	