

4

3

2

1

THIS DRAWING IS UNPUBLISHED. RELEASED FOR PUBLICATION APR, 2003.
 © COPYRIGHT 2003 BY TYCO ELECTRONICS CORPORATION. ALL RIGHTS RESERVED.

REVISONS		DESCRIPTION	DATE	DWN	APVD
P	LTR				
F		ECR-08-030242	02DEC08	AM	NC
F1		REVISED PER ECO-10-000444	18JAN10	KK	HMR

- NOTES:
- MATERIAL
 HOUSING : THERMOPLASTIC, UL94V-0, BLACK
 CONTACTS : PHOSPHOR BRONZE.
 SHELL : STEEL.
 SCREW : BRASS.
 BOARD LOCK : BRASS
 SCREW OF TORQUE : 5 Kg-cm MAX.
 - FINISH
 CONTACT : 15µ" MIN. GOLD PLATING ON CONTACT AREA
 100µ" MIN. TIN PLATING ON SOLDERTAILS
 50µ" MIN. NICKEL UNDERPLATED OVERALL
 SHELL : 60µ" MIN. TIN PLATING
 SCREW : 50µ" MIN. NICKEL PLATING.
 BOARD LOCK : 50µ" MIN. NICKEL PLATING.
 - CHARACTERISTICS
 CURRENT RATING : 3A
 INSULATION RESISTANCE : 1000MOHMS MIN, 500VDC FOR 2MINS.
 TEMPERATURE RATING : -55DEGC ~ +105DEGC
 VOLTAGE RATING : 250VDC

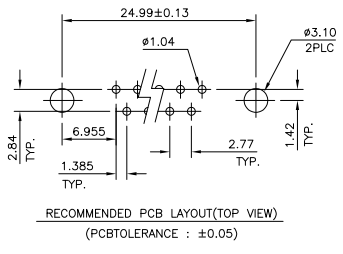
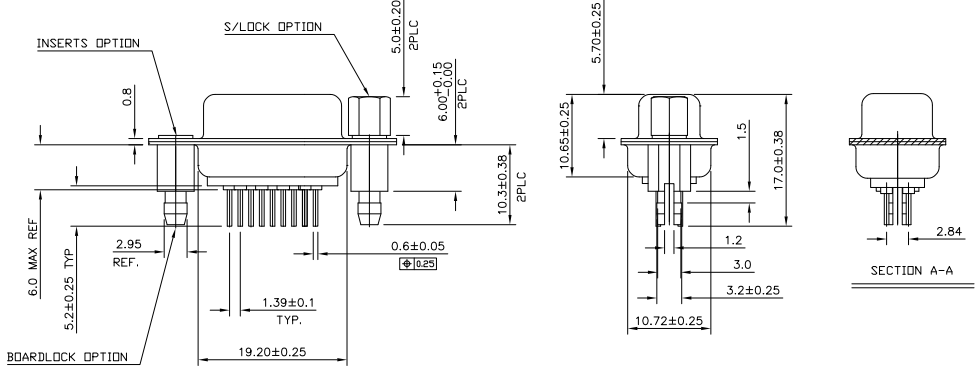
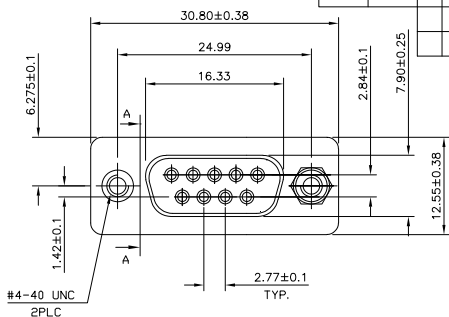

△ OBSOLETE	9W D SKT WITH B/L & M3 S/LOCK 15µ" GOLD	4-1634222-2
	9W D SKT WITH B/L & 4-40 S/LOCK 15µ" GOLD	3-1634222-2
△ OBSOLETE	9W D SKT WITH B/L & M3 INSERTS 15µ" GOLD	2-1634222-2
	9W D SKT WITH B/L & 4-40 INSERTS 15µ" GOLD	1-1634222-2

THIS DRAWING IS A CONTROLLED DOCUMENT.		DWN J.SANDWELL 10APR03	Tyco Electronics Corporation Stanmore, Middlesex, HA7 4RS	
DIMENSIONS: MM		CHK R.DYER 10APR03	NAME D-SUB HD20, VERTICAL, 9P SKT CONNECTOR	
TOLERANCES UNLESS OTHERWISE SPECIFIED: 0 PLC ± - 1 PLC ± 0.25 2 PLC ± 0.15 3 PLC ± - 4 PLC ± - ANGLES ± -		APVD F.WHEELER-KING 10APR03	PRODUCT SPEC -	
MATERIAL -		FINISH -	APPLICATION SPEC -	RESTRICTED TO -
		WEIGHT -	SIZE A3	CAGE CODE 00779
			DRAWING NO C=1634222	
CUSTOMER DRAWING		SCALE 2:1	SHEET 1	OF 2
			REV F1	

AMP 1470-19 REV 31MAR2000

4

3

2

1

THIS DRAWING IS UNPUBLISHED. RELEASED FOR PUBLICATION APR , 2003.
 © COPYRIGHT 2003 BY TYCO ELECTRONICS CORPORATION. ALL RIGHTS RESERVED.

LOC	DIST	REVISIONS			
P	LTR	DESCRIPTION	DATE	DWN	APVD
-	-	SEE SHEET 1	-	-	-

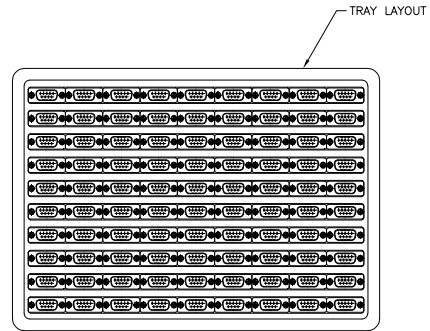
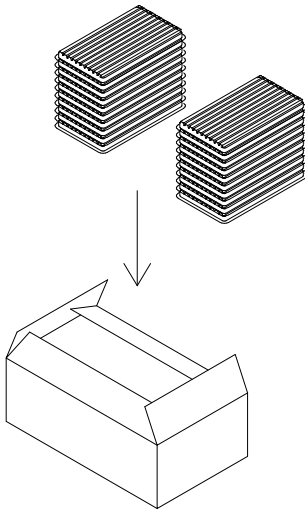
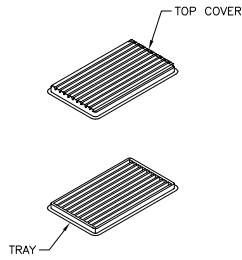

NOTES:

- MATERIAL
 1. TRAY: PVC
 2. SHIPPING CARTON: CORRUGATED FIBERBOARD

- DIMENSIONS
 1. TRAY: L=310, W=230, H=21
 2. SHIPPING CARTON: L=465, W=320, H=230

- QUANTITY
 90 PCS/TRAY
 20 TRAY/SHIPPING CARTON

THIS DRAWING IS A CONTROLLED DOCUMENT.		DWN J. SANDWELL 10APR03	Tyco Electronics Corporation Stanmore, Middlesex, HA7 4RS																												
DIMENSIONS: MM		CHK R. DYER 10APR03	NAME D-SUB HD20, VERTICAL, 9P SKT CONNECTOR																												
<table border="1"> <thead> <tr> <th colspan="2">DIMENSIONS:</th> <th colspan="2">TOLERANCES UNLESS OTHERWISE SPECIFIED:</th> </tr> </thead> <tbody> <tr> <td>0</td> <td>PLC</td> <td>±</td> <td>-</td> </tr> <tr> <td>1</td> <td>PLC</td> <td>±</td> <td>0.25</td> </tr> <tr> <td>2</td> <td>PLC</td> <td>±</td> <td>0.15</td> </tr> <tr> <td>3</td> <td>PLC</td> <td>±</td> <td>-</td> </tr> <tr> <td>4</td> <td>PLC</td> <td>±</td> <td>-</td> </tr> <tr> <td colspan="2">ANGLES</td> <td>±</td> <td>-</td> </tr> </tbody> </table>		DIMENSIONS:		TOLERANCES UNLESS OTHERWISE SPECIFIED:		0	PLC	±	-	1	PLC	±	0.25	2	PLC	±	0.15	3	PLC	±	-	4	PLC	±	-	ANGLES		±	-	APVD E. WHEELER-KING 10APR03	PRODUCT SPEC -
DIMENSIONS:		TOLERANCES UNLESS OTHERWISE SPECIFIED:																													
0	PLC	±	-																												
1	PLC	±	0.25																												
2	PLC	±	0.15																												
3	PLC	±	-																												
4	PLC	±	-																												
ANGLES		±	-																												
MATERIAL -		FINISH -	APPLICATION SPEC -	RESTRICTED TO -																											
		WEIGHT -	SIZE A3	CAGE CODE 00779																											
		DRAWING NO 1634222		REV F1																											
		CUSTOMER DRAWING		SCALE NTS																											
		SHEET 2		OF 2																											