

DESCRIPTION: **DIP SOLDER FEMALE/STAMPED**

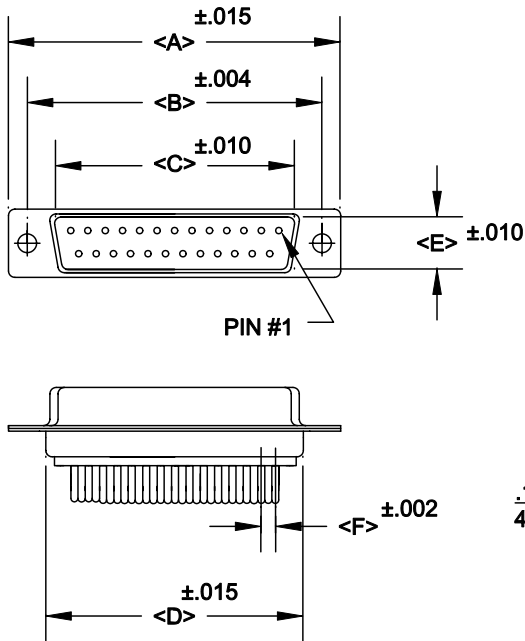

POS.	A	B	C	D	E	F	G
09	1.213	0.984	0.642	0.756	0.311	0.109	0.496
	30.80	24.99	16.30	19.20	7.90	2.77	12.60
15	1.541	1.312	0.971	1.091	0.311	0.109	0.496
	39.14	33.32	24.65	27.70	7.90	2.77	12.60
25	2.087	1.852	1.512	1.618	0.311	0.109	0.496
	53.00	47.04	38.40	41.10	7.90	2.77	12.60
37	2.728	2.500	2.157	2.256	0.311	0.109	0.496
	69.29	63.50	54.80	57.30	7.90	2.77	12.60
50	2.079	2.406	2.055	2.169	0.429	0.109	0.602
	52.81	61.00	52.20	55.10	10.90	2.77	15.30

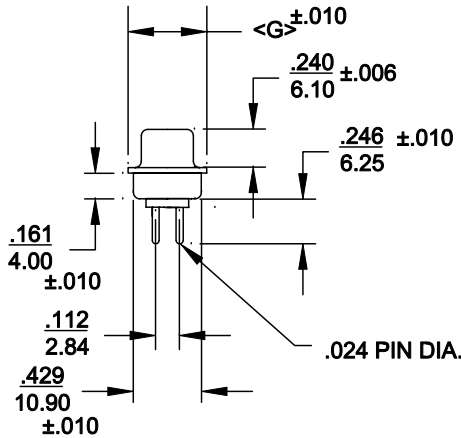

171-XXX-212-XX1

SERIES _____

POSITIONS _____

009 _____

015 _____

025 _____

037 _____

050 _____

GENDER _____

1 = MALE

2 = FEMALE

TERMINATION _____

1 = DIP SOLDER

SHELL PLATING _____

2 = TIN

HARDWARE OPTIONS _____

00 = NO HARDWARE

01 = .098 4-40 CLINCH NUT BOARD SIDE

02 = .250 4-40 CLINCH NUT BOARD SIDE

03 = .250 4-40 CLINCH NUT MATING SIDE

91 = .225 4-40 SPACER/BOARD LOCK

PLATING OPTIONS _____

1 = GOLD FLASH

2 = 30 MICRO-INCH GOLD

SPECIFICATIONS:

MATERIALS:

SHELL: STEEL, TIN PLATED
 INSULATOR: UL 94V-0 RATED BLACK PBT
 +30% FIBER-GLASS OR NYLON-66

ELECTRICALS:

CURRENT RATING: 5 AMPS
 CONTACT RESISTANCE: 15 mOHMS MAX
 INSULTOR RESISTANCE: 1000 MOHMS MIN
 VOLTAGE: 500V AC FOR 1 MINUTE
 TEMPERATURE: -50°C TO +100°C

	THESE DRAWINGS AND SPECIFICATIONS ARE THE PROPERTY OF NorComp AND SHALL NOT BE REPRODUCED, COPIED OR USED AS THE BASIS FOR THE MANUFACTURE OR SALE OF APPARATUS WITHOUT WRITTEN PERMISSION.		DRAWN: PAM JENKINS	DATE: 8-12-98
	NorComp		CHECKED:	DATE:
SCALE:			SHEET 1 OF 2	REV 5
		DWG NO. 171-XXX-21X-XX1		

DESCRIPTION: CLINCH NUT HARDWARE

ALL CLINCH-NUTS ARE 4-40 INTERNAL THREADS

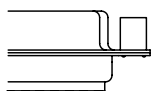

03X..... .250" (MATING SIDE) - CN8

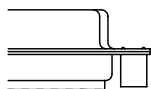

02X250" (BOARD SIDE) - CN2

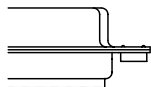

01X098" (BOARD SIDE) - CN1

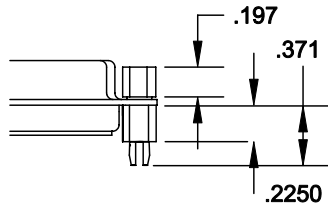



91X225" (BOARD SIDE) - .197 MATING SIDE - CN10/SFS0440
NOTE: 4-40 FEMALE SCREW LOCK IS REMOVABLE

	THESE DRAWINGS AND SPECIFICATIONS ARE THE PROPERTY OF NorComp AND SHALL NOT BE REPRODUCED, COPIED OR USED AS THE BASIS FOR THE MANUFACTURE OF SALE OF APPARATUS WITHOUT WRITTEN PERMISSION.		DRAWN: WAYNE ROBBINS	DATE: 8-23-98
			CHECKED: PAM JENKINS	DATE: 8-24-98
<h1>NorComp</h1>		SCALE:	SHEET 1 OF 1	REV 1
		DWG NO. CLINCH-NUT OPTIONS		

DESCRIPTION:

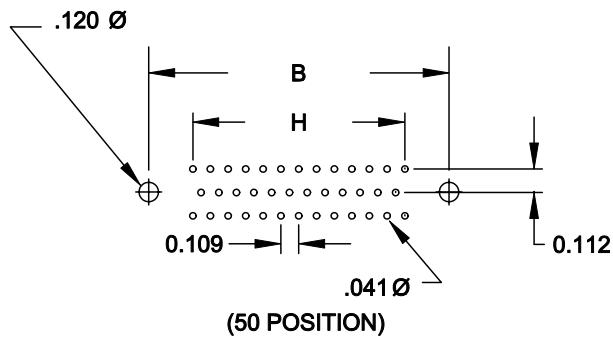
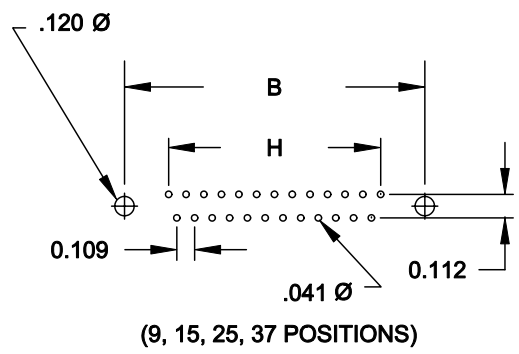
POS	H	
9	<u>.984</u> 25.00	<u>.433</u> 10.99
15	<u>1.312</u> 33.32	<u>.757</u> 19.23
25	<u>1.852</u> 47.04	<u>1.305</u> 33.15
37	<u>2.500</u> 63.50	<u>1.957</u> 49.71
50	<u>2.406</u> 61.11	<u>1.740</u> 44.20



	<small>THESE DRAWINGS AND SPECIFICATIONS ARE THE PROPERTY OF NorComp AND SHALL NOT BE REPRODUCED, COPIED OR USED AS THE BASIS FOR THE MANUFACTURE OF SALE OF APPARATUS WITHOUT WRITTEN PERMISSION.</small>		<small>DRAWN:</small> PAM JENKINS	<small>DATE:</small> 3-30-01
	NorComp			<small>CHECKED:</small>
<small>SCALE:</small>				<small>SHEET</small> 2 <small>OF</small> 2
<small>DWG NO.</small>		<small>DSUB VERTICAL FOOTPRINT</small>		