

REVISIONS				
REV.	EAR	DESCRIPTION	DATE	APPROVED
F	13741	NOTE UPDATES	JUL06/10	K.L

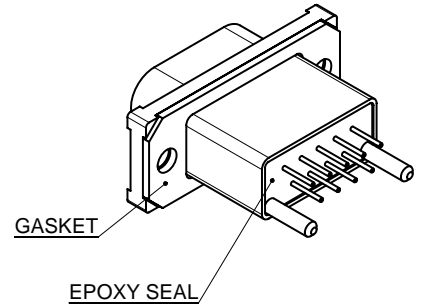

MDB-E09PA-765 IS SHOWN

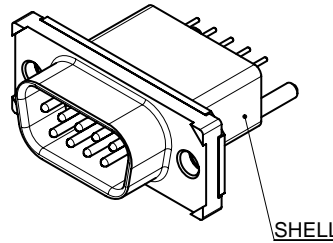
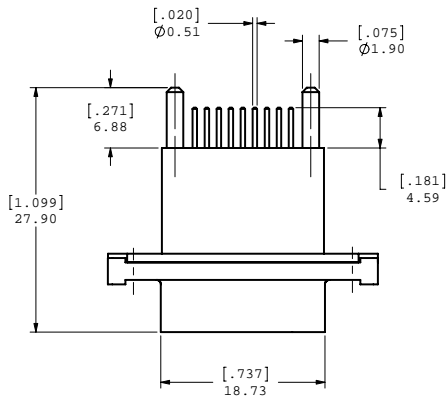
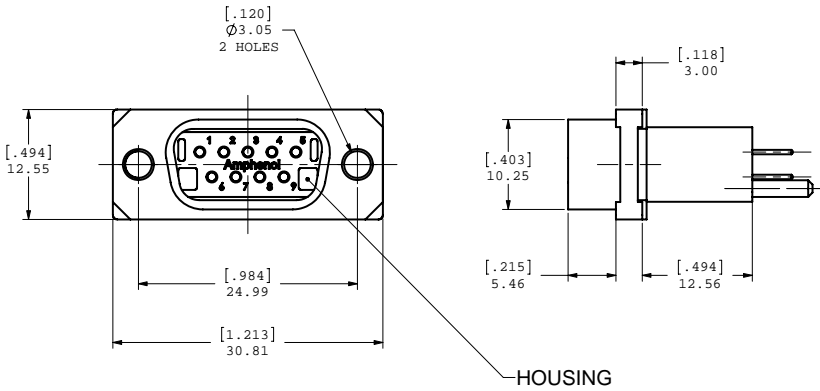

NOTES:

- MATERIAL:**
 - SHELL: ZINC ALLOY WITH 50 MICRO INCH MINIMUM NICKEL PLATING.
 - CONTACTS: COPPER ALLOY 30 MICRO INCH GOLD OVER 50 MICRO INCH NICKEL PLATING.
 - HOUSING: THERMOPLASTIC POLYESTER RESIN.
 - GASKET: SILICONE RUBBER.
 - SCREWS: STAINLESS STEEL.
 - DUST COVER: SILICONE RUBBER.
- FEATURES:** SEALED CONNECTOR IN THE MATED AND UNMATED CONDITIONS.
- OPERATING TEMPERATURE:** -40°C TO +105°C.
- ENVIRONMENT PERFORMANCE:** IP67.
- CONNECTOR IS ROHS COMPLIANT PER EU DIRECTIVE 2002/95/EC AND AMENDMENTS.**
- PART IS UL94V-0 FLAMMABILITY COMPLIANT.**
- PART NUMBER FOR ORDER:**
 - MDB-E09PA-760 - WITH DUST COVER AND SCREWS.
 - MDB-E09PA-765 - NO DUST COVER AND SCREWS.



UNLESS OTHERWISE SPECIFIED DIMENSIONS ARE IN MILLIMETER TOLERANCES ARE:		APPROVALS	DATE	Amphenol Canada Corp.
DECIMALS	ANGLES	DRAWN	OCT06/06	
XX ±.10	±1°	S.SEMENOV		
X ±.25		DESIGNED	OCT06/06	
MATERIAL AND FINISH		CHECKED		TITLE
REF.		QA APP'D		RUGGED 9 PIN, D-SUB CONNECTOR, VERTICAL MOUNT
CODE IDENT. NO.		IE APP'D		SIZE
		DWG APP'D	OCT06/06	C
		A.GREEN		DWG. NO.
				P-MDB-E09PA-76X
				REV.
				F
				SCALE
				3:1
				PROJECT
				MDB
				SHEET
				1 OF 2

DO NOT SCALE DRAWING
THIS DOCUMENT CONTAINS PROPRIETARY INFORMATION AND SUCH INFORMATION MAY NOT BE DISCLOSED TO OTHERS FOR ANY PURPOSE OR USED FOR MANUFACTURING PURPOSES WITHOUT PERMISSION FROM AMPHENOL CANADA CORP.



REVISIONS				
REV.	EAR	DESCRIPTION	DATE	APPROVED
F	13741	NOTE UPDATES	JUL06/10	K.L

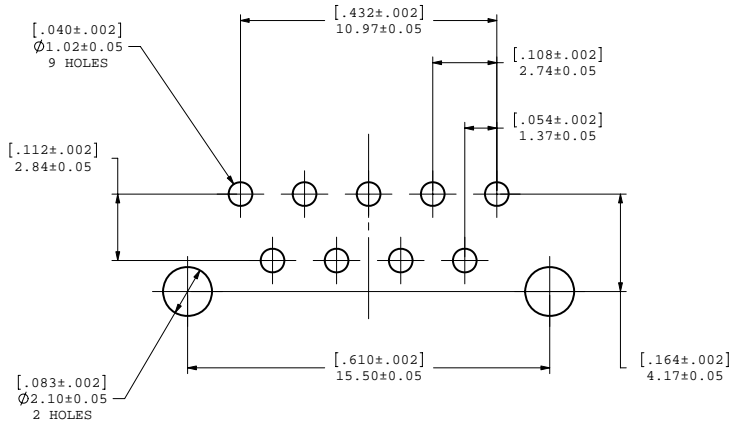

RECOMMENDED P.C.B. LAYOUT

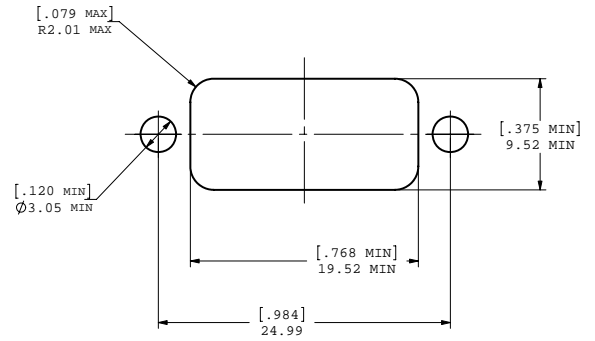

RECOMMENDED PANEL CUTOUT DIMENSIONS FOR REFERENCE ONLY

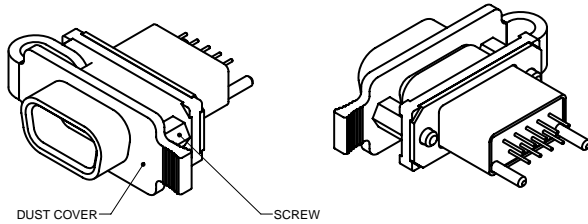

DUST COVER SCREW

MDB-E09PA-760 IS SHOWN

FOR MORE INFORMATION ABOUT DUST COVER, SEE DRAWING P-MDB-227-093-205BP



UNLESS OTHERWISE SPECIFIED DIMENSIONS ARE IN MILLIMETER TOLERANCES ARE:		APPROVALS	DATE	Amphenol Canada Corp.
DECIMALS	ANGLES	DRAWN	OCT06/06	
XX ±.10	±1°	S.SEMENOV		TITLE RUGGED 9 PIN, D-SUB CONNECTOR, VERTICAL MOUNT
X ±.25		DESIGNED	OCT06/06	
		S.SEMENOV		
MATERIAL AND FINISH		CHECKED		SIZE C
REF.		QA APP'D		DWG. NO. P-MDB-E09PA-76X
CODE IDENT. NO.		IE APP'D		REV. F
		DWG APP'D	OCT06/06	SCALE 3:1
		A.GREEN		PROJECT MDB
				SHEET 2 OF 2

DO NOT SCALE DRAWING
THIS DOCUMENT CONTAINS PROPRIETARY INFORMATION AND SUCH INFORMATION MAY NOT BE DISCLOSED TO OTHERS FOR ANY PURPOSE OR USED FOR MANUFACTURING PURPOSES WITHOUT PERMISSION FROM AMPHENOL CANADA CORP.